

Technical Datasheet No : 133_(v 2)

Part Number 600-044

25kN Digital Tensile Tester Kit, c/w Accessories & Heavy-Duty Case



Application – The Staht Tester Kit is designed to load test anchors and safety eye bolts up to a maximum load of 25 kN / 5620 lbf. The kit is supplied in a heavy-duty case.

Kit Content: 25kN Digital Load Cell (k) , Bridge (l), M16 Drop Rod & Sealed Thrust Nut (m), Anchor Jaw (n), Clevis (q), USB-C Charge Cable(o), Tool Lanyard for Tester (p), Threaded Washer Pack M6, 8, 10, 12, 16 (t), Slotted Washer Pack M6, 8, 10, 12 & 16 (u), 24mm Reversible Ratchet Spanner c/w Wrist Lanyard (v), Calibration Certificate & User Instructions, Heavy Duty Case & Filler.

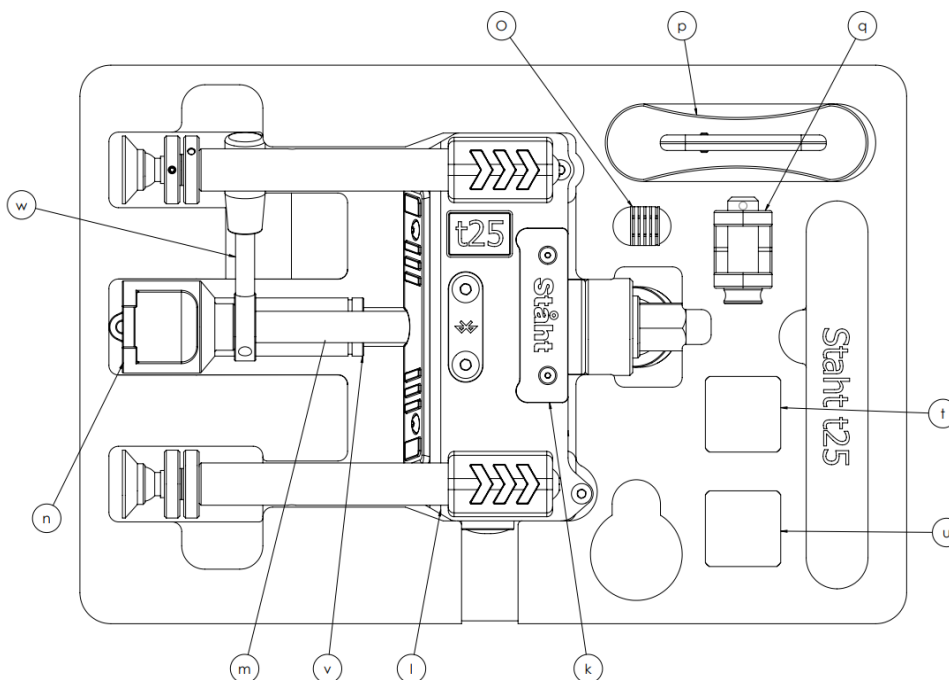

Technical Datasheet No : 133_{v 2}

Part Number 600-044

25kN Digital Tensile Tester Kit, c/w Accessories & Heavy-Duty Case

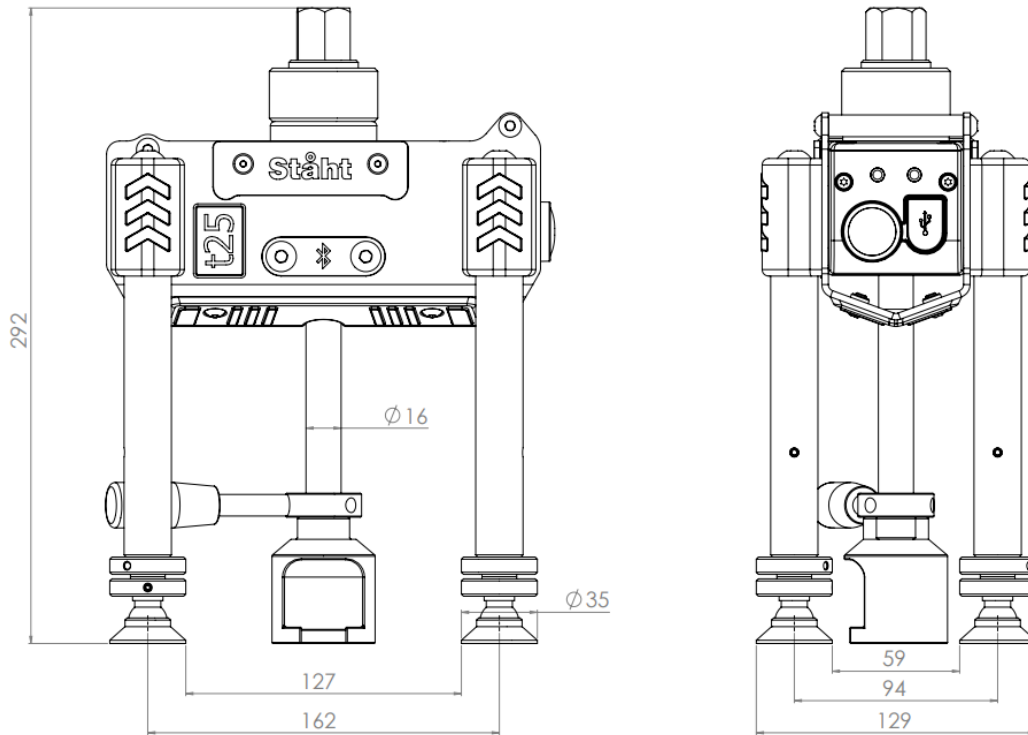

Specification

Operating Load Range	0 – 25 kN / 0 - 5620 lbf
Overload Warning	30kN / 6744 lbf
Operating Temperature Range	-20 to 60 °C / -4 to 140°F
Charging Temperature Range	0 to 45 °C / 32 to 113°F
Tester Weight (Tester Only)	4.1 kg / 9 lbs
Kit Weight & Dimensions	10.1 kg/ 22.2 lbs. 0.465 x 0.350 x 0.175 m / 18.3 x 13.8 x 6.9"
Packaged Weight & Dimensions	10.8 kg/ 23.8lbs. 0.5 x 0.385 x 0.21m / 19.6 x 15.15 x 8.27"
Tool Lanyard Length & Capacity	0.9 - 1.65 m ext / 31.5-65"ext. MAX 8 kg / 17.6 lbs
Wrist Lanyard Capacity	0.9 kg / 1.98 lbs
USB-C Braided Charge Cable	1 m / 39". 3 Amp
Connectivity	Staht Connect App via Bluetooth® LE
Battery	Rechargeable Li-Ion Polymer
Hydraulic Oil	ISO VG 32 Premium Mineral Based Oil
Test Standards	EN 61000-6-3:2007+A1:2011, EN 61000-4-2:2009, EN 61000-4-3+A1:2010 +A2:2010, EN 61000-4-6:2014
Certification	CE, UKCA

Technical Datasheet No : 101^(v 2)

Part Number 600-039

25kN Digital Tensile Tester Kit, c/w Accessories & Kit Bag



Application – The Stäht tester is designed to test anchors and safety eye bolts up to a maximum load of 25 kN / 5620 lbf. The kit is supplied in a durable kit bag.

Kit Content: 60kN Digital Load Cell , Bridge, M16 Drop Rod & Sealed Thrust Nut , Anchor Jaw, Clevis, USB-C Charge Cable, Tool Lanyard for Tester ,), 24mm Reversible Ratchet Spanner c/w Wrist Lanyard, Threaded Washer Pack M6, 8, 10, 12 & 16, Slotted Washer Pack M6, 8, 10, 12 & 16, Calibration Certificate & User Instructions, Padded Bag.

Specification

Operating Load Range	0 – 60 kN / 0 - 13489 lbf
Operating Temperature Range	-20 to 60 °C / -4 to 140°F
Overload Warning	30kN / 6744 lbf
Charging Temperature Range	0 to 45 °C . 32 to 113°F
Tester Weight	4.4 kg / 9.7 lbs
Kit Weight & Dimensions	8 kg / 17.6 lbs. 0.35 x 0.31 x 0.17 m / 13.8 x 12.2 x 6.69"
Packaged Weight & Dimensions	8.7 kg / 19.1 lbs. 0.5 x 0.385 x 0.21 m / 19.6 x 15.15 x 8.27"
Tool Lanyard Length & Capacity	0.9-1.65 m / 31.5-65". 8kg / 17.6 lbs
Wrist Lanyard Capacity	0.9 kg / 1.98 lbs
USB-C Braided Charge Cable	1 m /39". 3 Amp
Connectivity	Stäht Connect App via Bluetooth® LE
Battery	Rechargeable Li-Ion Polymer
Hydraulic Oil	ISO VG 32 Premium Mineral Based Oil
Test Standards	EN 61000-6-3:2007+A1:2011, EN 61000-4-2:2009, EN 61000-4-3+A1:2010 +A2:2010, EN 61000-4-6:2014
Certification	CE, UKCA