

MaxxPro[®]



FAMILY OF VEHICLES





**MAXIMUM
PROTECTION**



Protecting the Warfighter

The ND Defense MaxxPro Mine Resistant Ambush Protected (MRAP) vehicle is the go-to vehicle when danger is at its peak.

MaxxPro was originally developed to protect Warfighters and reduce casualties in Iraq from Improvised Explosive Devices (IEDs). Over the years, engineering enhancements have made MaxxPro the most adaptable, survivable wheeled vehicle in the world.



Mobility



Protection



Life Cycle Support

MaxxPro[®] Dash



The MaxxPro Dash is a lighter, smaller, and more mobile version of the original MaxxPro. The independent suspension is a no-compromise solution, allowing off-road mobility and a high-quality ride.

Horsepower: 375 hp (280 kw) @ 2,000 rpm; 450 hp (336 kw) optional

Torque: 1,250 lb-ft (1,695 Nm) @ 1,200 rpm; 1,350 lb-ft (1,830 Nm) optional

Suspension: Coil spring fully independent suspension

GVWR: 46,500 lbs (21,092 kg)

Width: 103.5" (2,629 mm)

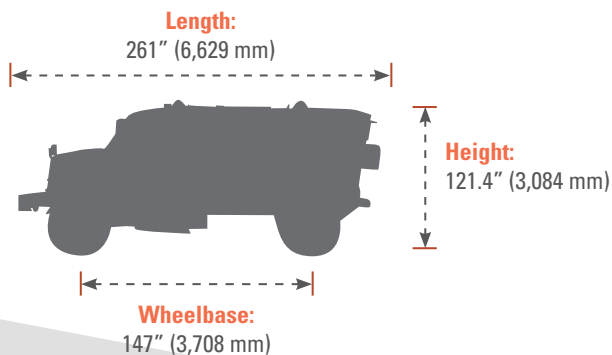

Armor Protection: Full range of Ballistic IED and Mine Blast Protection Solutions

Configurations:

- Troop Carrier (4 Troops)
- Remote Weapons Station

▶ **Seating:** up to 4 passengers + 1 gunner

▶ **Payload Capacity:** 10,000–14,000 lbs (4,536–6,350 kg)

MaxxPro[®] LWB



The MaxxPro LWB is a roomier and more mobile version of the original MaxxPro. It is an advantageous option for Allied militaries through the U.S. Excess Defense Article (EDA) program.

Horsepower: 395 hp (280 kw) @ 2,000 rpm; 450 hp (336 kw) optional

Suspension: Coil spring fully independent suspension

GVWR: 53,000 lbs (24,040 kg)

Torque: 1,250 lb-ft (1,695 Nm) @ 1,200 rpm; 1,350 lb-ft (1,830 Nm) optional

Width: 104.3" (2,649 mm)

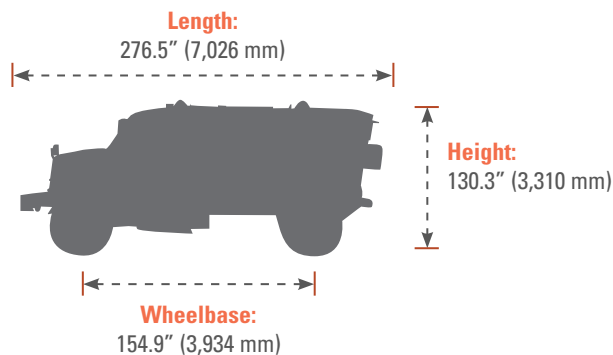

Armor Protection: Full range of Ballistic IED and Mine Blast Protection Solutions

Configurations:

- Troop Carrier (4-6 Troops)

▶ **Seating:** up to 6 passengers + 1 gunner

▶ **Payload Capacity:** 5,800 - 9,680 lbs (2,630 - 4,390 kg)

MaxxPro[®] LWB Ambulance



The MaxxPro LWB Ambulance provides the fully independent suspension and protection of the latest MaxxPro MRAP vehicles, while including features that convert the vehicle into a field ambulance capable of emergency transport and treatment space. The patient-loading system allows the crew to load and secure a litter patient in 30 seconds or less, minimizing exposure to the crew and patient(s) in hostile conditions..

Horsepower: 375 hp (280 kw) @ 2,000 rpm; 450 hp (336 kw) optional

Suspension: Coil spring fully independent suspension

GVWR: 53,000 lbs (24,040 kg)

Torque: 1,250 lb-ft (1,695 Nm) @ 1,200 rpm; 1,350 lb-ft (1,830 Nm) optional

Width: 104.3" (2,649 mm)

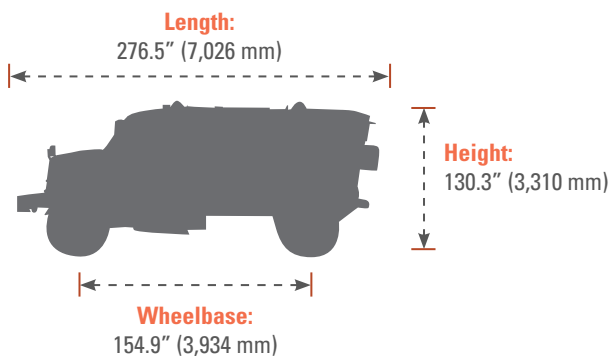

Armor Protection: Full range of Ballistic IED and Mine Blast Protection Solutions

Ambulance Configuration:

Configured to seat 1 medic and carry up to 4 ambulatory patients or two litter patients; includes various features and compartments designed to stow and support medical equipment.

▶ **Seating:** up to 4 passengers + 1 medic

▶ **Payload Capacity:** 5,800 - 7,500 lbs (2,630 - 3,402 kg)

MaxxPro[®] MRV-P



The MaxxPro MRV-P offers power, torque and mobility to conquer extreme off-road and soft soil terrains. Its independent front suspension, central tire inflation system (CTIS) and larger tires provide off-road maneuverability without sacrificing recovery capability.

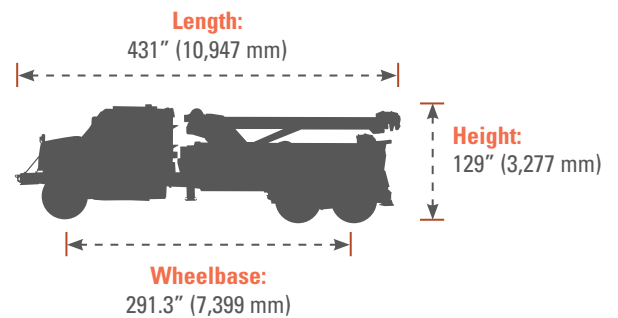

Horsepower: 450 hp (336 kw) @ 2,000 rpm

Torque: 1,200 lb-ft (1,627 Nm) @ 1,300 rpm

Suspension:

- **Front:** 27,000 lbs (12,247 kg) independent suspension system
- **Rear:** 67,200 lbs (30,481 kg) rated 62" (1,575 mm) tandem walking beam

GVWR: 94,199 lbs (42,728 kg)

Width: 103.5" (2,629 mm)

Body Type: Recovery body with 31.75 metric ton (35-short ton) boom and boom stabilizer, improved cable management system

MOBILITY

- Independent Front Suspension w/15" (381mm) wheel travel
- Super Single Tires w/ CTIS reduce ground pressure
- Excellent off-road capability

RECOVERY

- Unique boom recovery lift and radius
- Unique drag winch capability
- Highly adaptable hardware for broad range of recovery, including Stryker and all MRAP

Accessory Upgrade Summary: D-Ring, Hook Swivel Equalizer, Anti-skid Cribbing Pads, Spreader Bars, Boom Cable Strap, and Stryker Adapter Kit

Additional Features: Blackout Lights / Diamond Logic Electrical System, Runflats (optional), Central Tire Inflation System

Available as:

- New build vehicle
- Rolling chassis update

MaxxPro® Upgrades and Capability Insertion Kits

Warfighters around the world have come to rely on our MaxxPro vehicles to complete their missions safely. ND Defense takes this responsibility seriously. As threats and missions evolve, we've responded with design upgrades and enhancements to ensure Warfighters accomplish their tasks effectively and safely.



Mine Roller Adapter Kit

Interface mounting provision allows for quick installation of mine roller to vehicle.

- Vehicle interface withstands dynamic loading condition
- Provides additional NATO connector source on front bumper



Spare Tire Carrier Kit

Provides capability to carry additional tire in case of emergency.

- Manual loading and lowering system



CTIS Valve Cover

Provides protection to the wheel assembly Central Tire Inflation System (CTIS) valve minimizing damage that can result in loss of tire pressure.

- Easy bolt-on/bolt-off installation



MCOTM

Mission Command on the Move (MCOTM) provides commanders outside the wire with an enhanced level of battlefield situational awareness, while on the move, in the most survivable vehicle platform

- Four crew seats for command staff and a commander positions in the gunner's stand position
- DRS Data Distribution Unit (DDU): the C4ISR "brain" for all the systems
- Ruggedized digital displays at each seat position for managing/monitoring all C4ISR systems



MiCP

Modular Integrated Command Post (MiCP) combines the capabilities of the two Command Post Platform (CPP) currently in the Brigade TOC formation into one MaxxPro with Onboard Vehicle Power (OBVP).

- Consolidate footprint by installing communications suite in the rear of the vehicle
- Provide onboard and exportable power via transmission integrated Onboard Vehicle Power (OBVP) system



Transmission External Filter Kit

Allows replacement of transmission filter without removing armored underbelly blast protection system.

- Remote filter system relocates transmission filter to a readily accessible position
- Mounting solution allows for the ability to drain
- Remains located in an armored protected space



MaxxPro Survivability Upgrade (MSU)

Significantly increases blast mitigation of the MaxxPro fleet

- Bolt and weld solutions
- No noticeable visual difference from MaxxPro vehicles that do not have SMU
- Currently installed in all of U.S. Army's MaxxPro fleet



Ambulance Upgrade Kit

Protected transportation to load, triage, and evacuate injured military personnel from harm's way.

- Trolley system and hoist for quick litter loading
- Capacity for two litter patients or four ambulatory patients
- Rear facing medic seat that can also be used as a gunner platform



Rolling Chassis Upgrade

Provide improved off-road mobility capability and improved ride while maintaining armor protection by replacing original strait axle chassis.

- Replace leaf spring/beam axle with fully independent suspension
- Install existing body on a new chassis



Electronic Stability Control Upgrade

Adds traction control and roll stability to existing anti-lock brake system for increased crew and vehicle safety.

- Counters loss of directional control to help prevent rollovers
- Improves safety and driving performance
- Cost-effective solution that can be installed in approximately 30 hours



Onboard Vehicle Power Kit

Increases endurance and assurance of power for uninterrupted communications in a survivable vehicle.

- Uses base vehicle "to bring energy forward"
- Increases flexibility of mobile power generation/distribution
- Integrated starter generator



EOD

Explosive Ordnance Disposal (EOD) provides low risk ground robot deployment and 360-degree situational awareness capability

- Storage for Two EOD Robots
- Integrated VOSS
- Auto-deploy Robot Ramp
- Modular Interior Storage
- Interrogator Arm



Route Clearance Kit

Allows for remote investigation and identification of possible explosive devices from a safe distance.

- Interrogator arm to identify, pick up, and remove hazards
- Extends up to 8.5m (28')
- Interrogator arm camera and light capable of being controlled from inside the vehicle



Engine Power Upgrade

ND Defense remanufactured longblock engine provides more power for tactical operations.

- Repurpose current engine with upgraded longblock, as a more cost effective solution compared to buying new
- Increases power from 279 kw (375 hp) to 336 kw (450 hp)

Lifecycle Support

Warfighters depend on our vehicles.

Building the best military vehicles is only the start of what we do at ND Defense. Even the highest quality vehicles need ongoing maintenance and support to stay deployment ready, so we provide complete lifecycle support for every vehicle we make. No matter where they go, we'll be there.

Originated from one of the largest makers of medium and heavy trucks, ND Defense utilizes more than 100 years of experience supporting large fleets. ND Defense leverages an extensive global footprint to provide and support ongoing maintenance and repairs to ensure operational readiness.

RESET

After combat operations have taken their toll on military equipment, ND Defense can reset previously deployed and battle-damaged MaxxPro vehicles to 10-20, or like new, condition. We offer customized configurations and scope to meet mission and budgetary requirements. These comprehensive upgrade and repairs improve vehicle performance and lifecycle.



Before Reset



After Reset



**ENSURING
OPERATIONAL READINESS**



DEFENSE™

 [NDdefense.com](https://www.nddefense.com)

 [/NDdefenseLLC](https://www.facebook.com/NDdefenseLLC)

 [/company/ND-defense](https://www.linkedin.com/company/ND-defense)

 [youtube.com @NDdefense](https://www.youtube.com/@NDdefense)