

Electric Vehicle DC Charging Station 180kW / 240kW

Instruction Manual



Note: Please read this instruction manual carefully before using the product.

Contents

Chapter 1 Product Overview	3
Chapter 2 Protection Function	3
Chapter 3 Scope Of Application.....	3
Chapter 4 Product Parameters	4
Chapter 5 Installation Method And Drawing	5
5.1 Overall Dimensions Of The Equipment	5
5.2 Installation of Equipment.....	6
5.2.1 Packing List	6
5.2.2 Installation Environment Requirements.....	6
5.2.3 Installation Method	6
5.3 Cable Access.....	8
Chapter 6 Operation Instructions.....	9
6.1 Operation Area.....	9
6.2 Operation Instructions	9
6.3 System Settings	12
Chapter 7 Storage And Transportation	16
7.1 Storage And Transportation Of Equipment	16
Chapter 8 Common Faults And Solutions Of EV DC Charger Station.....	16
Chapter 9 Maintenance And Preservation Of EV DC Charging station.....	19
9.1 Maintenance	19
Chapter 10 Warranty Card.....	20

Chapter 1 Product Overview

A nuclear-safe high-power power module platform is adopted, Higher safety and reliability;

Adopt a new high-efficiency three-phase PFC circuit topology, The power factor is greater than 0.99, Harmonic distortion rate is low $\leq 5\%$;

The high-frequency switching power supply module adopts the full-bridge phase-shift soft switching technology; High execution efficiency;

Advanced digital current sharing technology, Effectively improve current sharing accuracy and anti-interference;

The first module sleep technology and rotation technology, to ensure the efficient operation of the system;

Intelligent charging process control and perfect charging process monitoring and protection, Ease of use;

With timing charging, Quantitative charging, A variety of charging methods such as fixed amount charging and automatic charging are available;

Real-time display of the charged amount, Charging time, Current electricity price, Information such as charging price and operating status;

Provide optional GPRS networking mode; Module hot swap technology, Make maintenance more convenient;

Charging stations can be additionally equipped with a charging cable support device (Retractor) to Prevent damage to the cable due to friction with the ground. The Retractor also helps keep the cable Clean.

The housing is made of stainless or galvanized steel sheet and structural parts made of ABS plastic.

Working environment temperature: $-35^{\circ}\text{C} \sim +55^{\circ}\text{C}$.

Chapter 2 Protection Function

The input and output of the EV Charger Station are electrically isolated;

The output has a device to prevent the battery pack from charging the output filter capacitor of the EV Charger station, prevent instantaneous high current at the output terminal of the EV Charger station when the battery pack is connected;

The voltage rating of the charging station, Insulation class, Electric Vehicle Conductive Charging Device Regulations;

Design according to the functions of: 2014/35/EL (The Low Voltage Directive), 2014/30/EU, EN IEC 62196-1 in EN IEC 62196-3, IEC 62893-1, 2,3 in 4, EN IEC 61851-1:2019, EN IEC 61851-21-2:2021, EN IEC 61851-21-2:2021, EN IEC 61851-23 in 25, IEC 61000-6-2:2016, IEC 61000-6-4:2019, EN IEC 61000-6-1:2019, EN IEC 61000-6-3:2021, EN 17186:2019, EN 301 489-3 V2.3.2:2023, EN ISO 15118-1...-5.

 CE certified

Chapter 3 Scope Of Application

Integrated DC EV Charger Station is suitable for city-specific charging stations (Bus, taxi, official vehicle, sanitation vehicle, logistics vehicle, etc.), City public charging station (Private car, commuter car, bus), Various parking lots in urban residential quarters, shopping plazas, power business places, etc.;

Inter-city expressway charging stations and other occasions that require DC fast charging, It is especially suitable for rapid deployment under limited site conditions.

Chapter 4 Product Parameters

EV Charging Station Parameter Table

Product Name		Integrated DC Charging Station (Metal Type)
Model		Commercial Use
		AF-DC-180-Y-B-O-3/4/5/6-H, AF-DC-240-Y-B-O-3/4/5/6-H
Specification	Rated Power	180kW, 240kW
Charging Device	Installation Method, Route	Floor-stand mounted, Bottom in and bottom out
	Equipment Dimension	1800*800*600 (mm)
	Input Voltage	AC380V ± 15%
	Input Frequency	50±10Hz
	Number of phases	3
	Output Voltage	200-1000 VDC
	Single Gun Output Current Range	CCS2: 0-250A
	Cable Length	5m (Optional)
	Metering Accuracy	Level 1
Electrical Specification	Current Limit Protection Value	≥110%
	Voltage Stabilization Accuracy	≤±0.5%
	Current Stabilization Accuracy	≤±1%
	Ripple Ratio	≤±0.5%
	Efficiency	≥95%
	Power Factor	≥0.99 (above 50% load)
	Harmonic Content THD	≤5% (above 50% load)
Functional Design	HMI	7- inch highlight color touch LCD++LED indicator strip
	Operation status indication	Three-color, LED
	Charging Mode	Automatic full charge/ Fixed energy/ Fixed amount/ Fixed time
	Charging Methods	NFC (Swipe to charge), scan QR code to charge
	Payment Methods	RFID, scan QR code, Credit card, Password, APP
	Network Interface	Ethernet, 4G, LTE, WiFi 802.11 b/g/n (Optional, 2.4/5 GHz)
	Executive standard	2014/35/EL (The Low Voltage Directive), 2014/30/EU, EN IEC 62196-1 in EN IEC 62196-3, IEC 62893-1, 2,3 in 4, EN IEC 61851-1:2019, EN IEC 61851-21-2:2021, EN IEC 61851-21-2:2021, EN IEC 61851-23 in 25, IEC 61000-6-2:2016, IEC 61000-6-4:2019, EN IEC 61000-6-1:2019, EN IEC 61000-6-3:2021, EN 17186:2019, EN 301 489-3 V2.3.2:2023, EN ISO 15118-1...-5
	EVSE to Backend	OCPP1.6J (optional OCPP2.01)
Safety Design	Safety Function	Charging gun temperature detection, overvoltage protection, under voltage protection, overload protection, short circuit protection, grounding protection, over temperature protection, low temperature protection, insulation monitoring protection, polarity

		reverse protection, lightning protection, emergency stop protection, leakage protection.
Environmental Indicators	Working Temperature	-35°C ~ +55°C
	Working Humidity	5%~95% non-condensing frost
	Working Altitude	<2000m (optional ≤2500m)
	Ingress Protection	IP54
	Cooling Method	Air-cooled
	Noise Control	≤60dB
	MTBF	17520 hours

NOTICE: The charging station provides control over power parameters when organizing its inclusion in a hub of charging stations with dynamic balancing of the power of the charging session between stations.

Chapter 5 Installation Method And Drawing

5.1 Overall Dimensions Of The Equipment

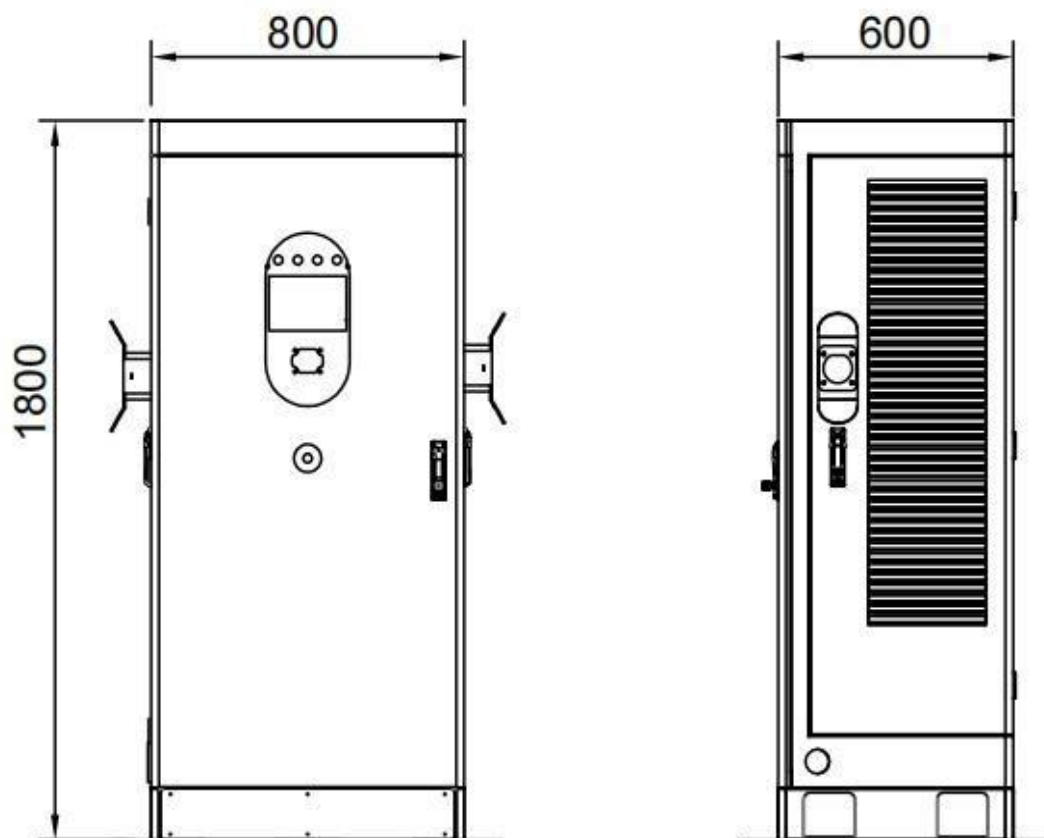

Figure 5-1-1 Overall Dimensions Of The Device

5.2 Installation of Equipment

5.2.1 Packing List

Check the packing box for the following items before installation (subject to the packing list)

1. Vertical type DC charging station (1 set)
2. Test card (2 pieces) [with card reader or not]
3. Installation manual (1 set)
4. Certificate of quality (1 piece)
5. Key (2 pieces)

5.2.2 Installation Environment Requirements

1. This series EV DC charging station are the outdoor type, Ingress Protection: IP54;
2. Ambient temperature: -35°C to +55°C;

5.2.3 Installation Method

1. This series of DC charging station can be installed vertically according to the requirements Installation size, as the Figure 5-2-1 and Figure 5-2-2:

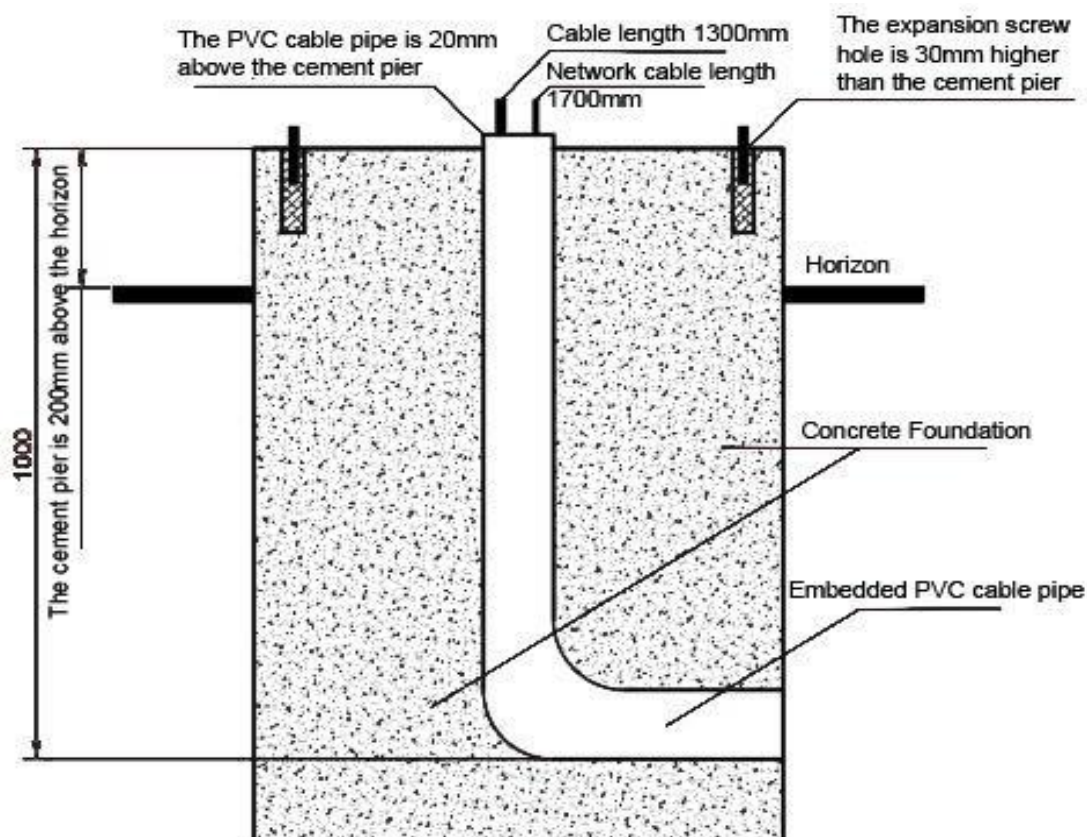

Figure 5-2-1 Vertical Type Installation Method

ATTENTION!

Installation and connection of the station must be performed by qualified personnel.

Incorrect installation and adjustment of the station may damage the battery.

Do not install automatic reset systems on the zero-sequence current protection device.

Do not install or use the station near flammable, explosive, aggressive or hot materials, chemicals or vapors.

The supplied power line must have an automatic switch.

Failure to follow these instructions will result in death or serious injury.

1. Charging stations are placed on a horizontal surface with a concrete or asphalt surface.

The station is stationary and must be securely fastened to the base with metal spikes completely immersed in concrete.

2. The high-voltage wire must be grounded with a screen to the installation site of the charging station.

3. Make sure that the voltage is disconnected.

4. Make sure there is no mechanical damage to the charging station.

5. Install the charging station on the installation site. The base of the station must fit tightly to the foundation.

6. Pass the power cable through the mounting hole.

7. Secure the charging station to the installation site using the holes in the base of the charging station. The charging station can be secured with either spikes or anchors, depending on the installation location.

8. Connect the high-voltage cable to the circuit breaker. Connect the grounding cable.

Attention: the station will not work without the grounding cable.

10. The method of connecting to the network is permanent connection.

NOTICE: 6620 Conversion Board for OCPP Access Setting Method Connection.

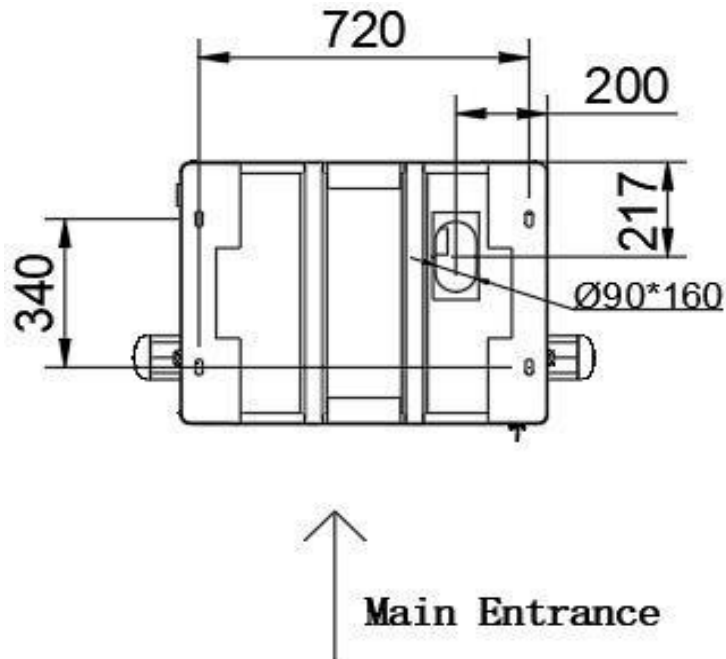
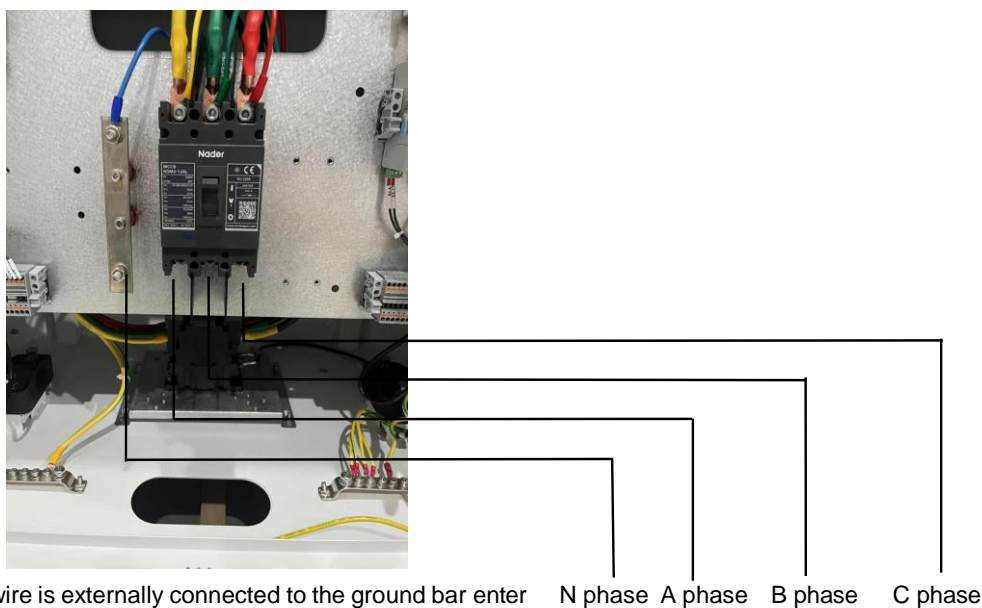

Figure 5-2-2 Floor Stand Type Installation Method

5.3 Cable Access

Connect the three-phase cable which embedded in the station foundation to the input end, note the five lines connection method, corresponding color, the cabinet bus bar connects the earthing wire, Shown in figure 5-3-1: Schematic diagram of electric vehicle EV Charger station cable connection.



The ground wire is externally connected to the ground bar enter N phase A phase B phase C phase

Figure 5-3-1 Cable Access

Chapter 6 Operation Instructions

6.1 Operation Area



Figure 6-1-1 Starting Interface

The operation area mainly includes LCD, Card reading area.

The 800x480 resolution color touch screen displays the charging parameters and the operation prompt information, card reader area used to identify the ID and user information.

6.2 Operation Instructions

1. Click other charging methods to enter the charging interface.

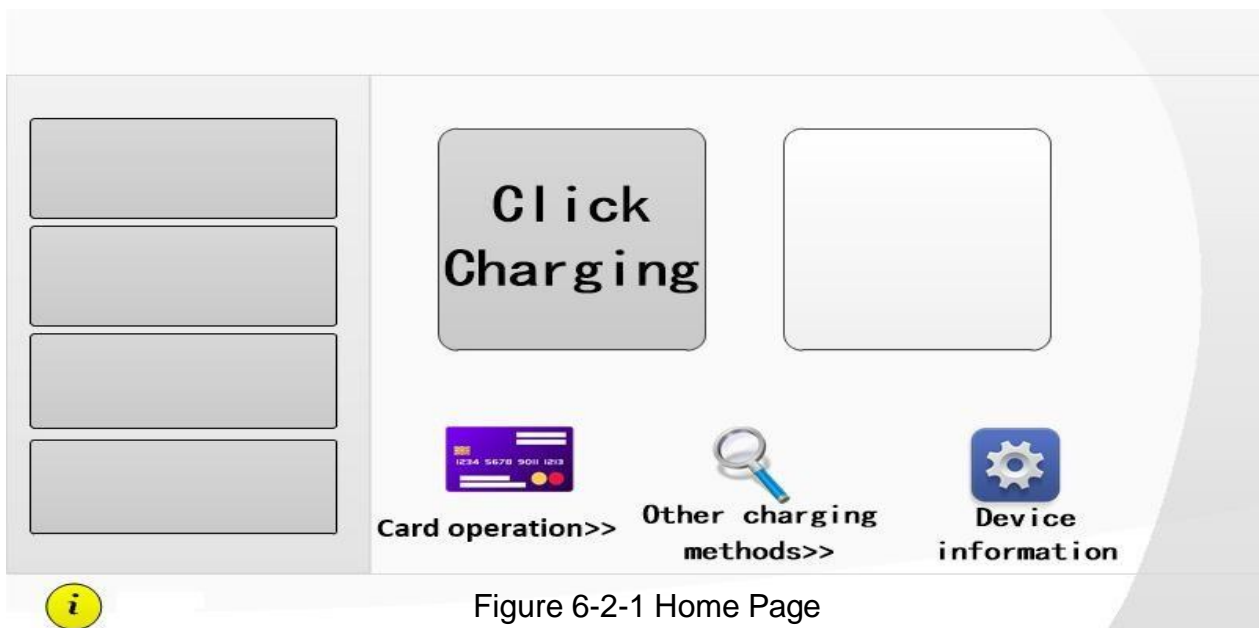

Figure 6-2-1 Home Page

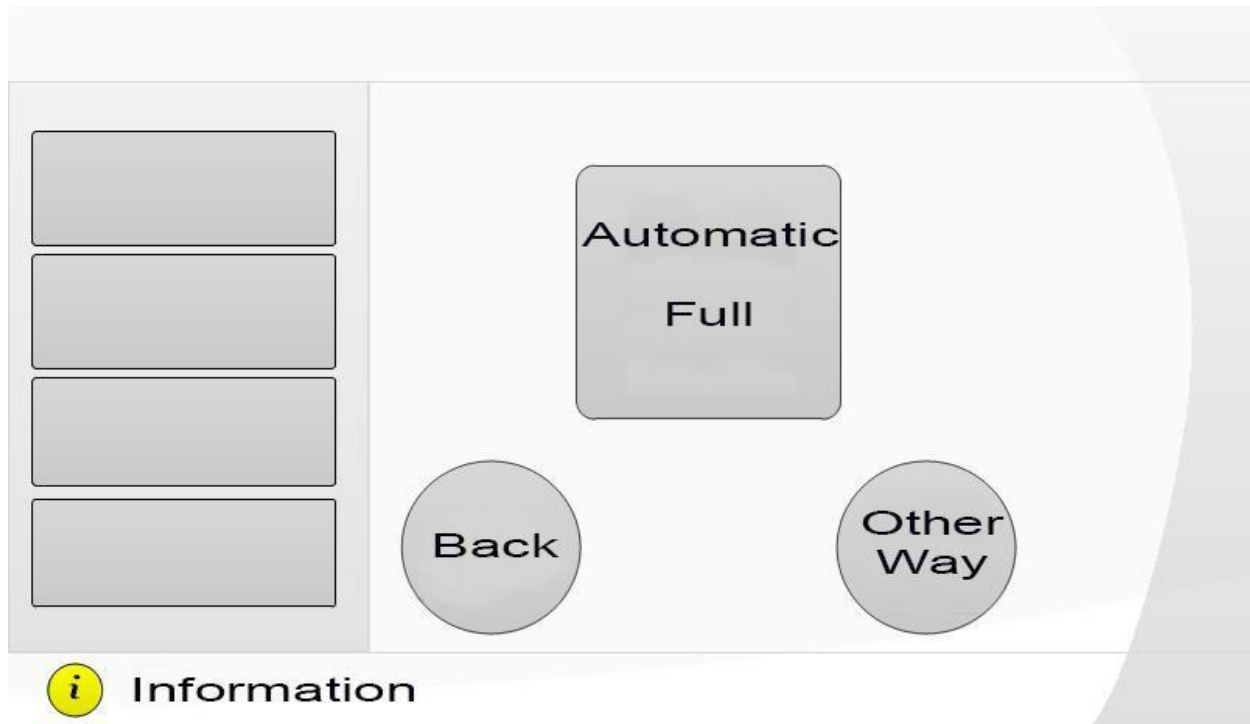

Figure 6-2-2 Select Charging Mode

2. Card swiping charging interface

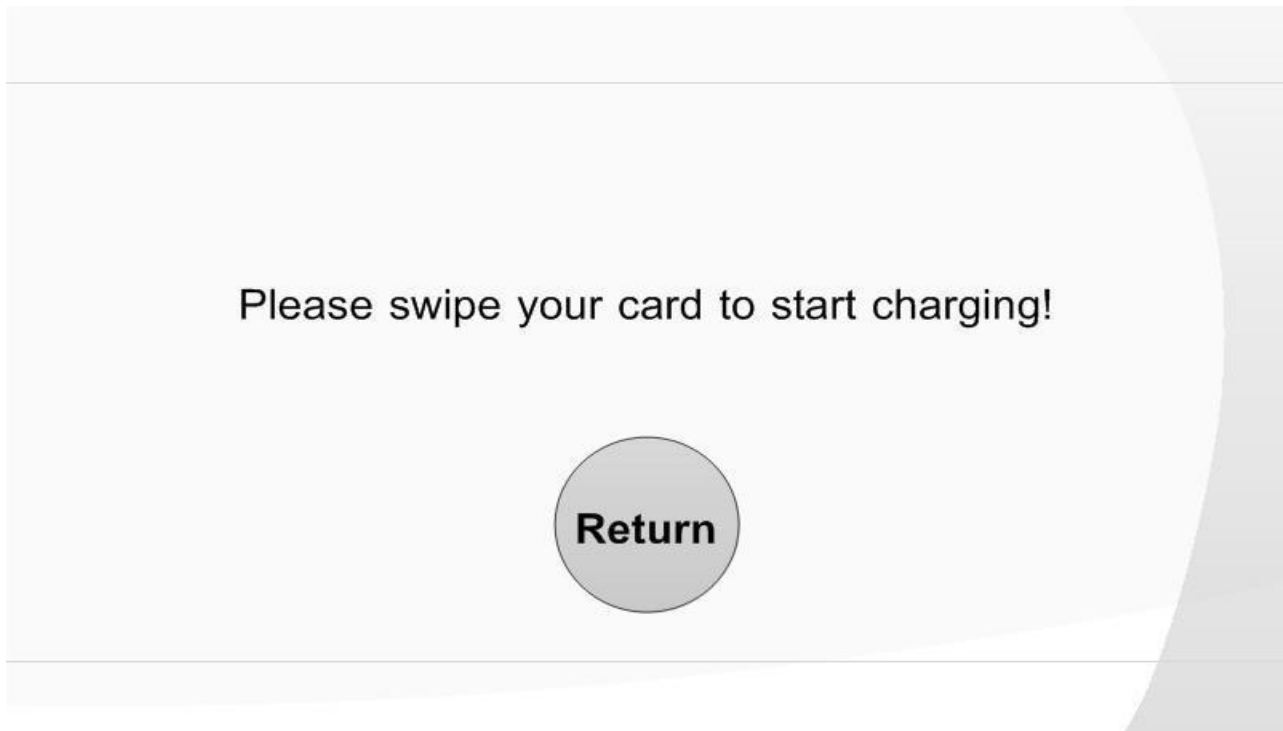
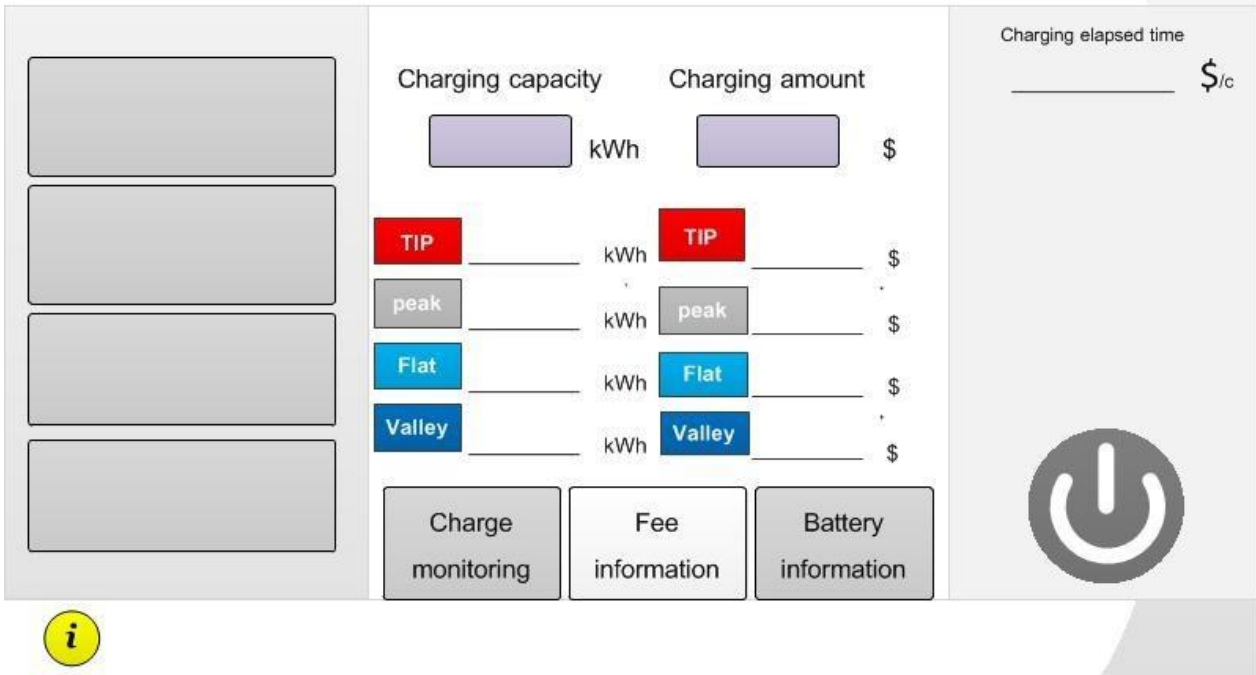
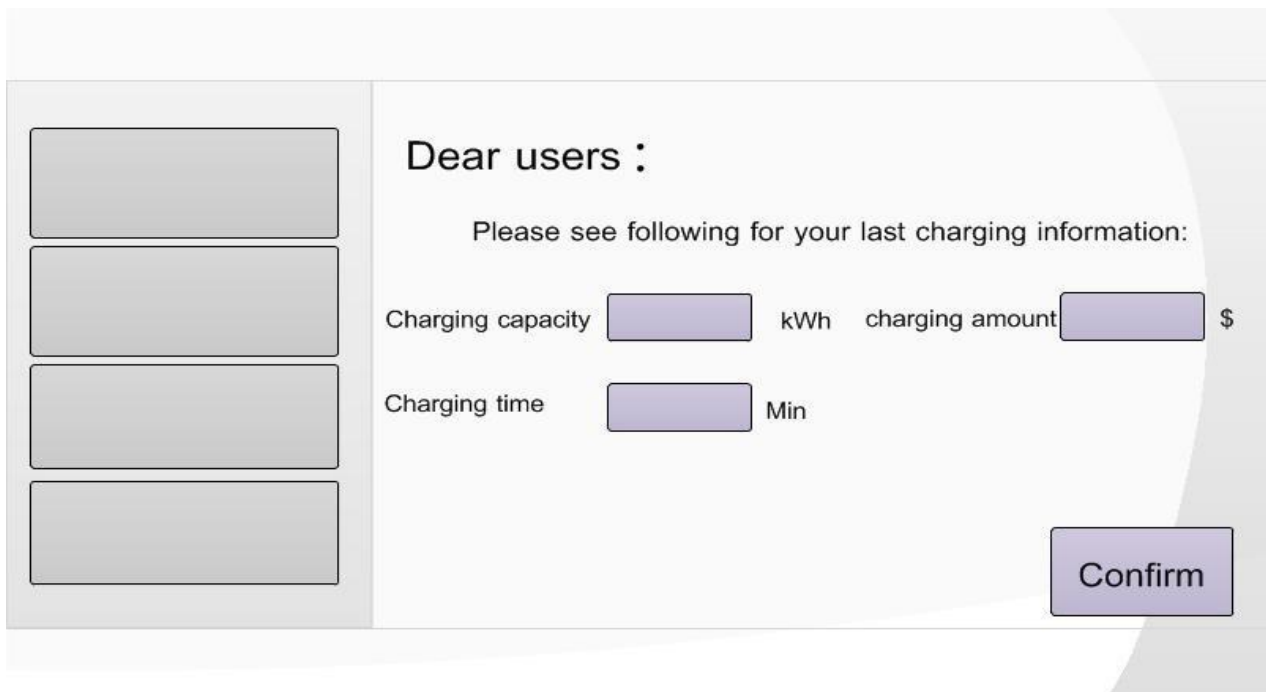

Figure 6-2-3 Swipe Card Interface



The screenshot shows a charging interface with a sidebar on the left containing four empty rectangular boxes. The main area is divided into two columns. The left column is titled 'Charging capacity' and contains five input fields with colored labels: 'TIP' (red), 'peak' (grey), 'Flat' (blue), and 'Valley' (blue). Each field is followed by 'kWh'. The right column is titled 'Charging amount' and contains five input fields with the same colored labels: 'TIP' (red), 'peak' (grey), 'Flat' (blue), and 'Valley' (blue). Each field is followed by '\$'. Below these columns are three buttons: 'Charge monitoring', 'Fee information', and 'Battery information'. On the far right, there is a section for 'Charging elapsed time' with a '\$/c' label and a large power button icon.

Figure 6-2-4 Charging Interface



The screenshot shows a settlement interface. On the left, there is a sidebar with four empty rectangular boxes. The main area starts with the text 'Dear users :'. Below this, it says 'Please see following for your last charging information:'. There are two rows of input fields: the first row for 'Charging capacity' (kWh) and 'charging amount' (\$), and the second row for 'Charging time' (Min). A 'Confirm' button is located at the bottom right.

Figure 6-2-5 Settlement Interface

6.3 System Settings

1. Click Set button, enter password, then enter the set interface.

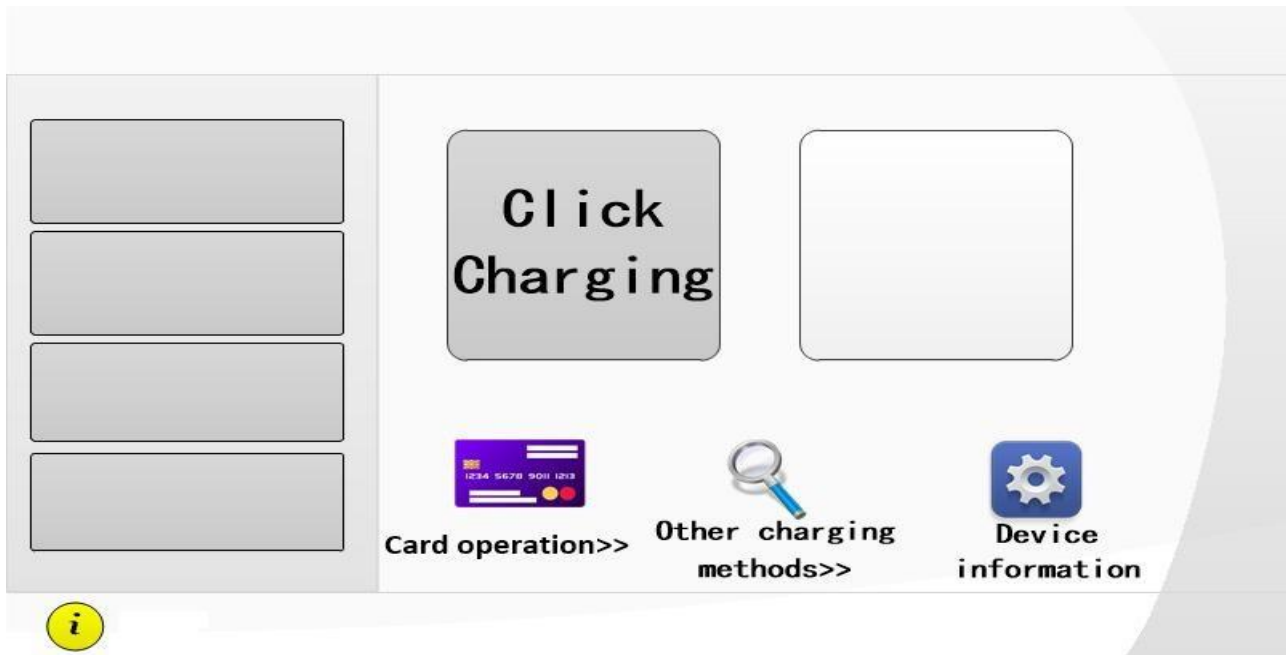

Home Page

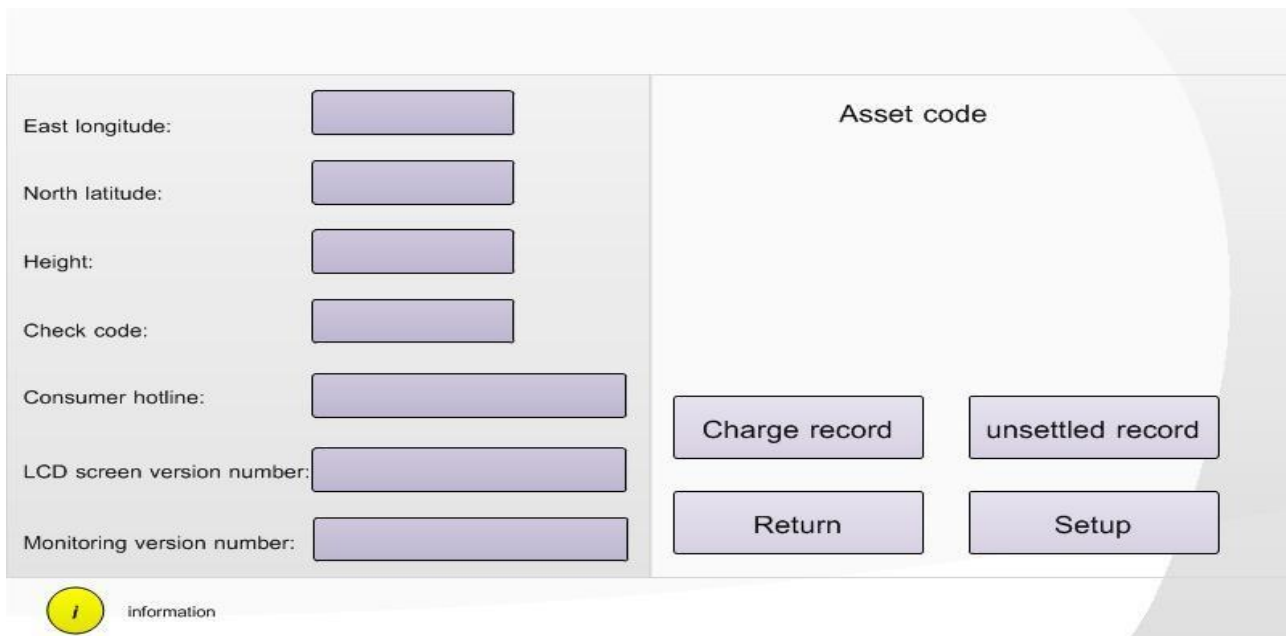

Click the [Set] button to enter the password input interface

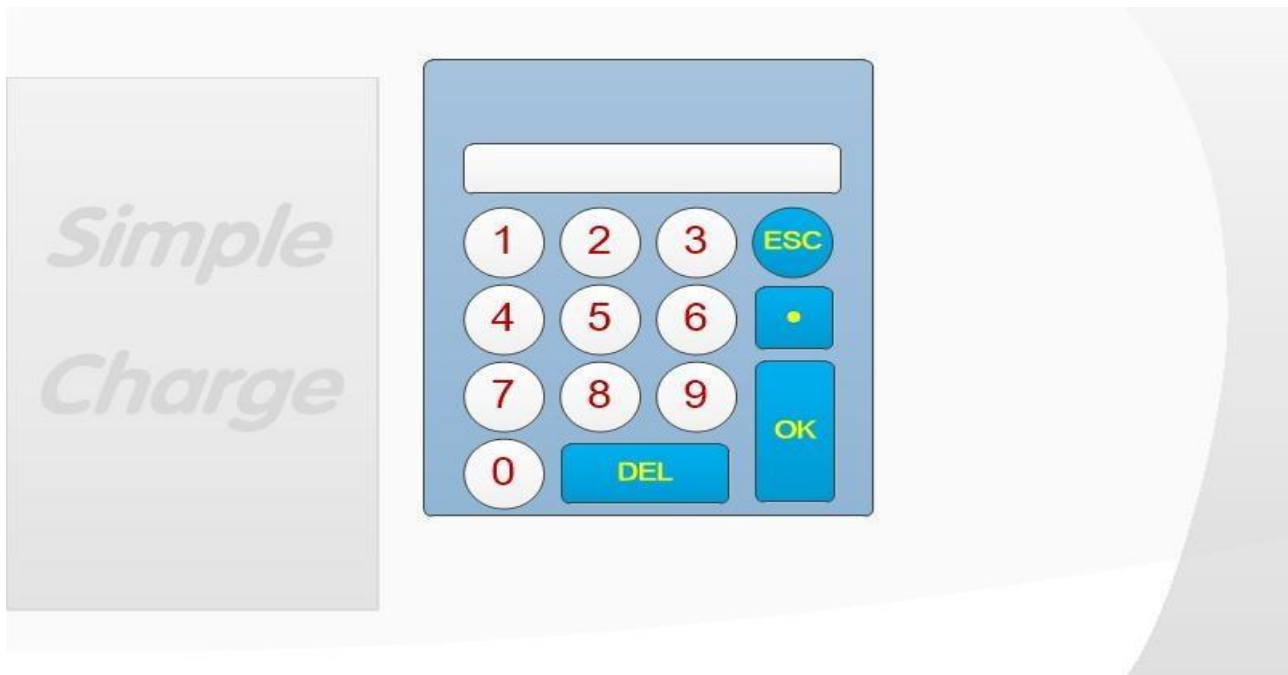

Password Page (Password Input Interface)

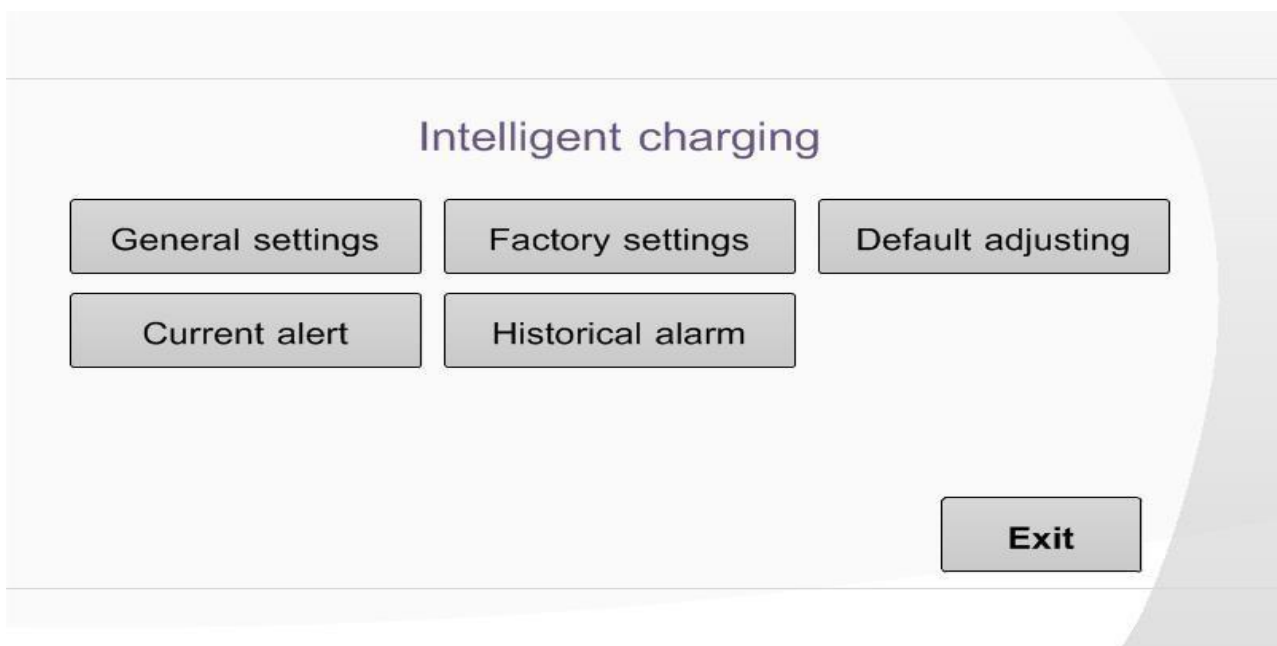

Main Operation Setting Interface

2. Click general settings to enter the setting interface

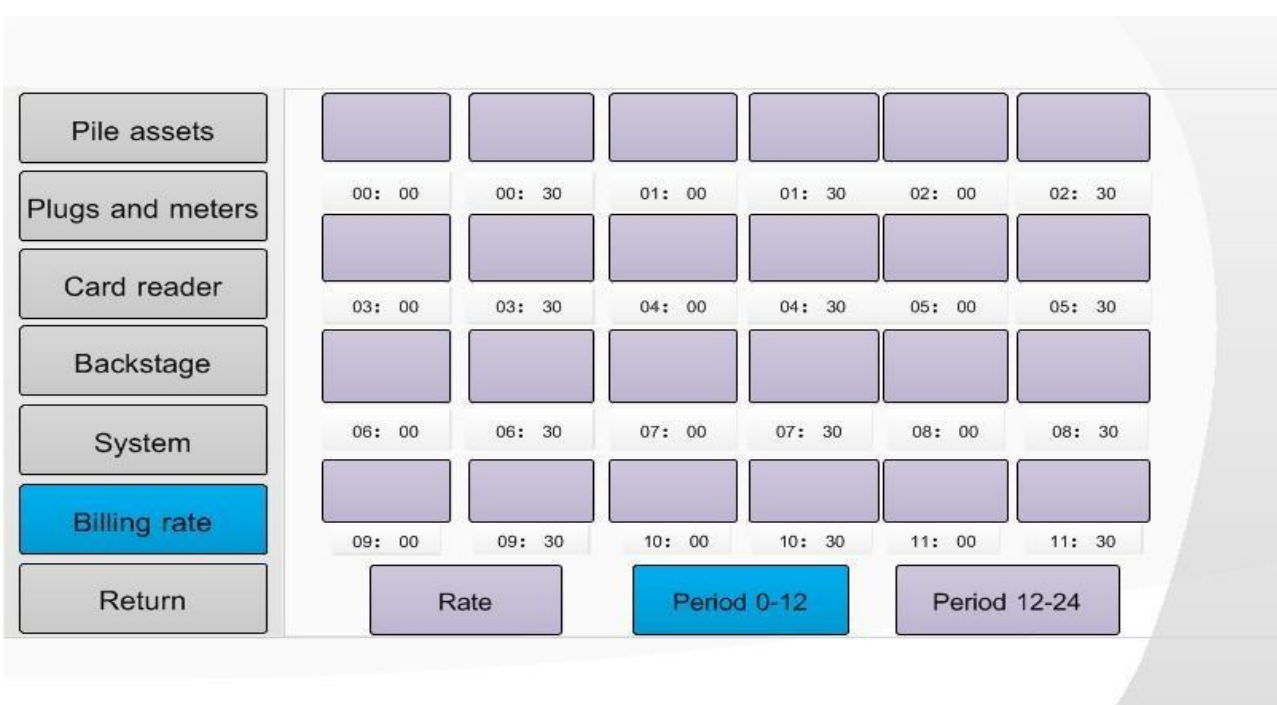

The screenshot shows the 'Billing rate' configuration screen. On the left is a vertical menu with options: Pile assets, Plugs and meters, Card reader, Backstage, System, Billing rate (highlighted in blue), and Return. The main area features a 6x2 grid of time slots from 00:00 to 11:30. Below the grid are three buttons: 'Rate', 'Period 0-12' (highlighted in blue), and 'Period 12-24'.

Time Of Use Tariff Setting Interface

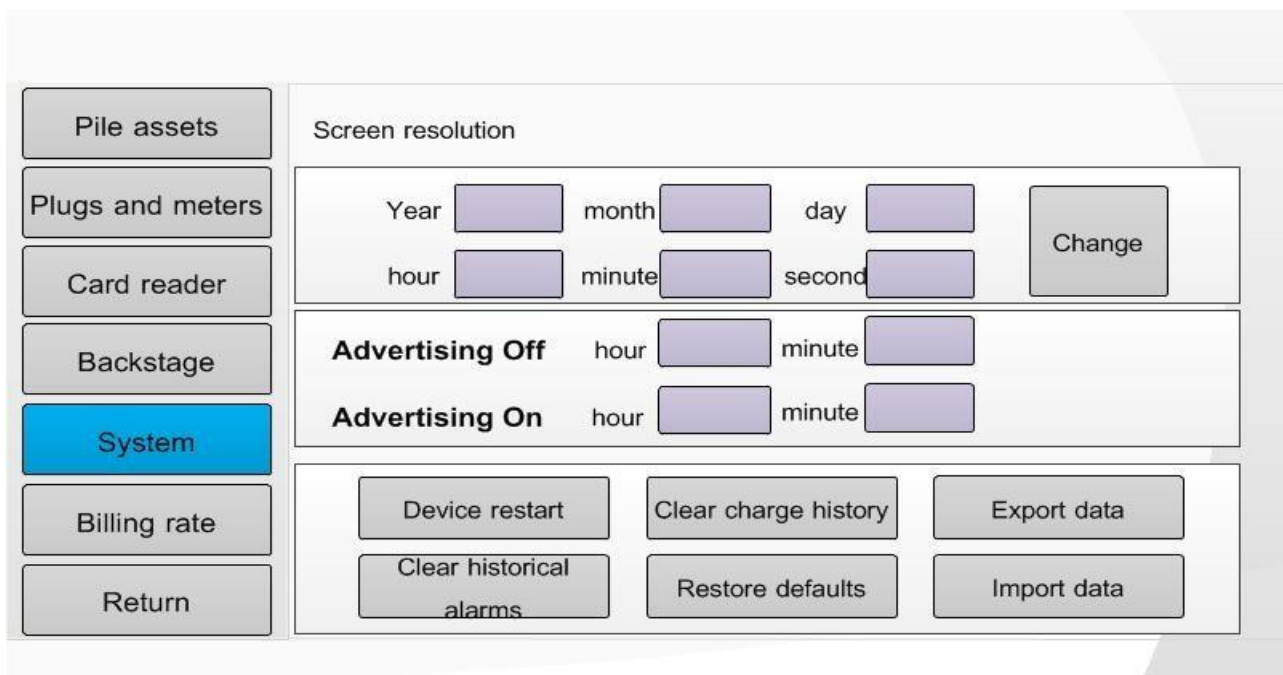

The screenshot shows the 'System' settings screen. The left menu includes: Pile assets, Plugs and meters, Card reader, Backstage, System (highlighted in blue), Billing rate, and Return. The main content area is divided into sections: 'Screen resolution' with input fields for Year, month, day, hour, minute, and second, and a 'Change' button; 'Advertising Off' and 'Advertising On' with hour and minute input fields; and a bottom section with six buttons: Device restart, Clear charge history, Export data, Clear historical alarms, Restore defaults, and Import data.

World Setting Interface

3. Click the Historical alarm button in the settings interface



Historical Alarm Interface

4. Click the order record button in the setting interface



Order Record Interface

Chapter 7 Storage And Transportation

7.1 Storage And Transportation Of Equipment

During transportation, it is necessary to use a sturdy wooden box to pack the charging station body firmly and intact and mark the direction of loading and unloading, and it is forbidden to store and transport the charging station upside down. There should be corresponding fastening measures during transportation to avoid damage to the outer packaging of the equipment caused by strong vibration and bumps. After arrival, check whether the charging station is damaged, and if there is any transportation damage, it should be solved by negotiation with the transporter and our company in time. After unpacking, check that the contents of the box match the packing list immediately.

Packaged equipment should be stored in a room with a relative humidity of $\leq 80\%$ and an ambient air temperature of $-10^{\circ}\text{C} \sim +40^{\circ}\text{C}$. The storage place should be kept dry, clean and well ventilated, and can prevent the intrusion of various harmful gases. It is strictly forbidden to store it in the same place with corrosive items.

Note: Non-professionals are strictly prohibited from dismantling equipment components.

Chapter 8 Common Faults And Solutions Of EV DC Charger Station

Serial No.	Common Malfunctions	Method Of Exclusion
1	The screen and indicator light are off and there is no response.	<p>(1) Check the plastic shell of the charging station input wire and the secondary circuit to see if there is any leakage or tripping.</p> <p>1.1. If it trips, please power it on again. If it trips again immediately after powering on, please do not force power on. Recheck the input wiring to see if there is any misconnection. If it is correct, please contact the manufacturer for repair;</p> <p>1.2. The input wire plastic shell and the secondary circuit leaked and tripped, and the surface was charred. It is most likely that the input wire terminal was not tightened, causing the switch to burn out. Please contact the manufacturer for repair.</p> <p>(2) There is no problem with the input wire plastic shell and secondary circuit leakage. Check the line voltage.</p> <p>2.1. Use a multimeter or test electric pen to measure whether there is voltage in the input wire and the voltage is normal; then visually check whether the main board and switching power supply lights are on normally. If not, please contact the manufacturer for repair;</p> <p>2.2. Use a multimeter or a test electric pen to check whether there is voltage in the input wire. The plastic shell is broken and the</p>

Serial No.	Common Malfunctions	Method Of Exclusion
		<p>voltage is normal, but the secondary circuit is leaking and has no voltage, please check whether the surge is damaged. If it is damaged, please replace it in time;</p> <p>2.3. Use a multimeter or test electric pen to measure whether there is voltage in the input wire. If there is no voltage, please re-power on and check whether the charging station is damaged.</p> <p>(3) Check whether the emergency stop is pressed.</p> <p>3.1. If pressed, please turn the emergency stop head clockwise, the emergency stop will pop up and then release.</p>
2	The screen and indicator lights dim and turn on and off	<p>(1) Check whether the input wire is under-voltage.</p> <p>1.1. If there is under-voltage, please contact the transformer manufacturer for repair.</p> <p>(2) Check whether the switching power supply outputs $12 \pm 0.5V$ normally.</p> <p>2.1. If the voltage is unstable, please contact the manufacturer for replacement.</p>
3	A fault alarm appears on the screen, causing the charging station to fail to charge normally.	<p>(1) Press the emergency stop button.</p> <p>1.1. If pressed, please turn the emergency stop head clockwise, the emergency stop will pop up and then release.</p> <p>(2) The equipment door is opened.</p> <p>2.1. Check whether the cabinet door is open. please close it before charging.</p> <p>(3) The BMS connection timeout.</p> <p>3.1. The switching power supply is burned out; A fault alarm appears on the screen, causing the charging station to be unable to charge normally.</p> <p>(4) Insulation failure.</p> <p>4.1. Check whether the car is powered off;</p> <p>4.2. Whether the car has just been powered off? If so, please re-try again after 1-2 minutes after the car is powered off.</p> <p>(5). The pre-charge startup module failed.</p> <p>5.1. Check whether the module CAN line is connected normally and whether the resistance is 60Ω ;</p> <p>5.2. Check whether the module reports a fault, is burned out, or the indicator light does not light up.</p> <p>(6) BMS communication timeout.</p> <p>6.1. The vehicle BSM requires 24V, and the customer chooses 12V power;</p> <p>6.2. The station doesn't have 24V and is powered by BMS power</p>

Serial No.	Common Malfunctions	Method Of Exclusion
		supply. The customer didn't mention this requirement when purchasing, please contact the manufacturer to add it later; 6.3. The vehicle itself has problems. It may be a very old car or a non-standard car that is not produced according to GB27930. This situation can be checked by intercepting the message.
		(7) Background communication abnormality. 7.1. Check whether the network card has expired and whether the site network signal is too poor.
4	When the gun is plugged in, the interface doesn't show the connection or no display	Check whether the air inlet or outlet of the charging station is blocked. If so, please clean or replace the filter cotton in time.
5	The gun locked up and could not be pulled out after the power was cut off due to special circumstances.	There is a mechanical unlocking key on the gun head. Insert it into the unlocking hole and rotate it to unlock it. If it can't be unlocked, please do not violently disassemble it and please contact the site staff.
6		For other faults, please contact the manufacturer for guidance and repair.

Symptoms of common faults of the indicator lights on the module panel:

There are three indicator lights on the module panel, which are the power indicator (green light), the protection indicator (yellow), and the fault indicator (red), and the fault indicator is as follows:

Indicator Light	Normal Status	Abnormal State	Abnormal Problem
Power Indicator (Green)	On	Off	No input voltage to the module internal auxiliary power supply doesn't work
Protection Indicator (Yellow)	Off	On	AC input over-voltage, under-voltage, over-temperature
	Off	On	Communication interruption, manual mode
Fault Indicator (Red)	Off	On	Output over-voltage, module address duplication, module severe uneven current
	Off	Flashing	Faulty fan

Note: When the module is in manual mode, the yellow light flashes.

Chapter 9 Maintenance And Preservation Of EV DC Charging station

9.1 Maintenance

Charging stations should be shaded and rainproof, and it is recommended to install a canopy outdoors.

Regularly check whether all bolts in the charging station are tightened, whether the connection line is loose, and the connection is not firm. Check for short circuits.

Pay attention to lightning protection to ensure effective shielding and reliable grounding of charging stations.

Try to control the output voltage and current of the charging station within the nominal range when used to ensure that the charging station works in the state of maximum efficiency.

When the charging station stops in use, stop the charging output first, and then wind the cable back to its original position.

Note: During the transportation of the charging station, the charging station is firmly packed and marked with the direction of loading and unloading, and it is forbidden to store and transport the charging station upside down; and there are corresponding fastening measures to avoid strong vibration and bumps that damage the outer packaging of the equipment.

Note: Non-professionals are strictly prohibited from dismantling equipment components.

Chapter 10 Warranty Card

Warranty Regulations

1. The warranty period of this product is 3 years.
2. Our 24-hour service hotline (400-805-5677) is always available.
3. The customers make an appointment for door-to-door repair service within 48 hours of warranty.
4. During the warranty period, the faults (judged by the official staff of the company) that occur under normal use according to the instructions for use will be repaired free of charge.
5. Except for the following problems, the charging equipment can enjoy the above-mentioned relevant warranty terms:
 - 5.1 Unable to provide this warranty card and valid purchase certificate;
 - 5.2 Beyond the warranty period stipulated by the manufacturer;
 - 5.3 There is no warranty card and valid purchase certificate, or the content on the warranty order is inconsistent with the physical identification of the repaired product or has been altered;
 - 5.4 Damage caused by use, maintenance, and customs declaration doesn't meet the standards of the product instruction manuals;
 - 5.5 Damage or malfunction due to entry of foreign objects;
 - 5.6 Malfunction caused by products not manufactured by our company;
 - 5.7 Damage caused by dismantling by those who are not responsible for the three-guarantee repair;
 - 5.8 Damage caused by force majeure (such as lightning, over voltage, earthquake, fire, flood and other natural disasters);
 - 5.9 Damage or malfunction caused due to unavoidable external factors;
 - 5.10 Damage caused by water ingress or other solutions of the equipment due to improper use;
 - 5.11 Damage caused by using a power supply or voltage other than the specified one.
6. The foregoing warranty is made only and without any other express or implied warranty (including implied warranties of merchant ability, reasonableness and fitness for a particular application), whether in contract, civil negligence, or otherwise, the Company shall not be liable for any special incidental or consequential damages.

For Customer

Product name : _____ Serial number: _____

Product type : _____

Date of manufacture : _____ (Subject to commissioning and acceptance)

Stamp of Manufacturer :

Customer name : _____ Tel : _____

Customer signature : _____

Customer ADD : _____

1. Warranty content : _____ After-sales service : _____

Customer signature : _____

2. Warranty content : _____ After-sales service : _____

Customer signature : _____

3. Warranty content : _____ After-sales service : _____

Customer signature : _____

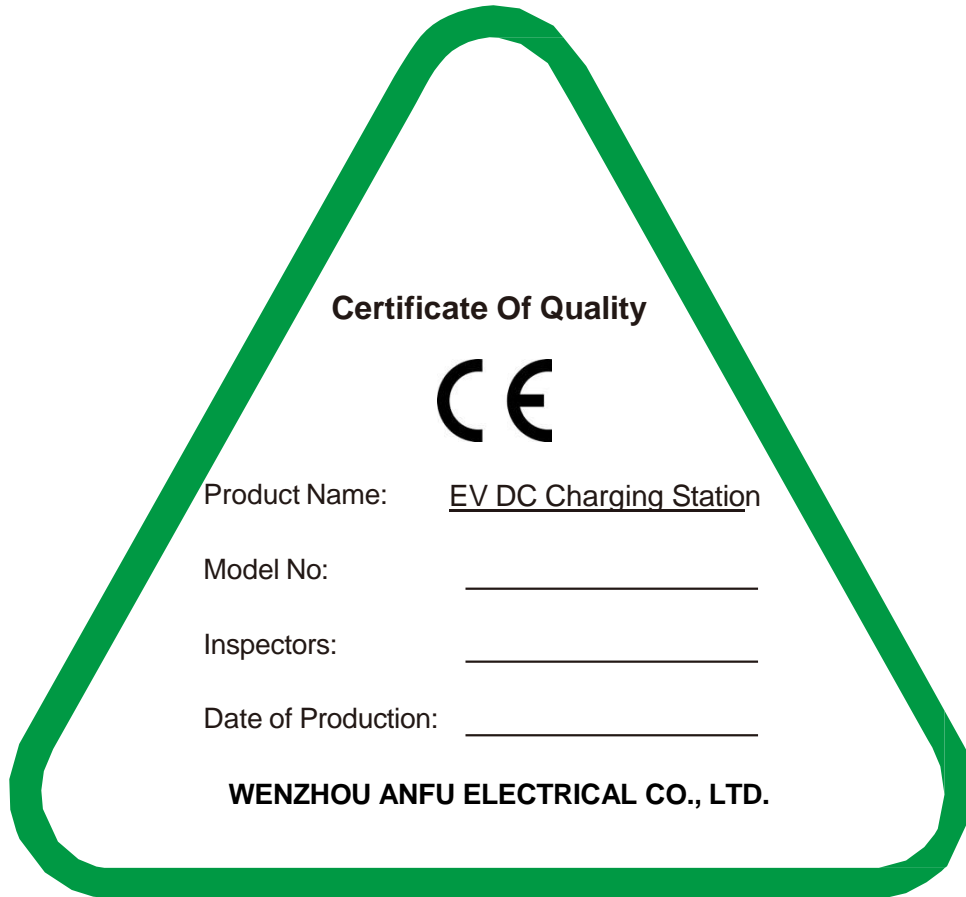

Assembly and testing of the equipment are carried out by DOBRATEH, d.o.o. under the supervision of WENZHOU ANFU ELECTRICAL CO., LTD.

(date _____).

Specialist responsible for assembly and control _____