

# Our most versatile 496 LED system.

## FRAMELED VERSA

A modular cabinet  
designed for  
exhibitions, corporate  
events and more.

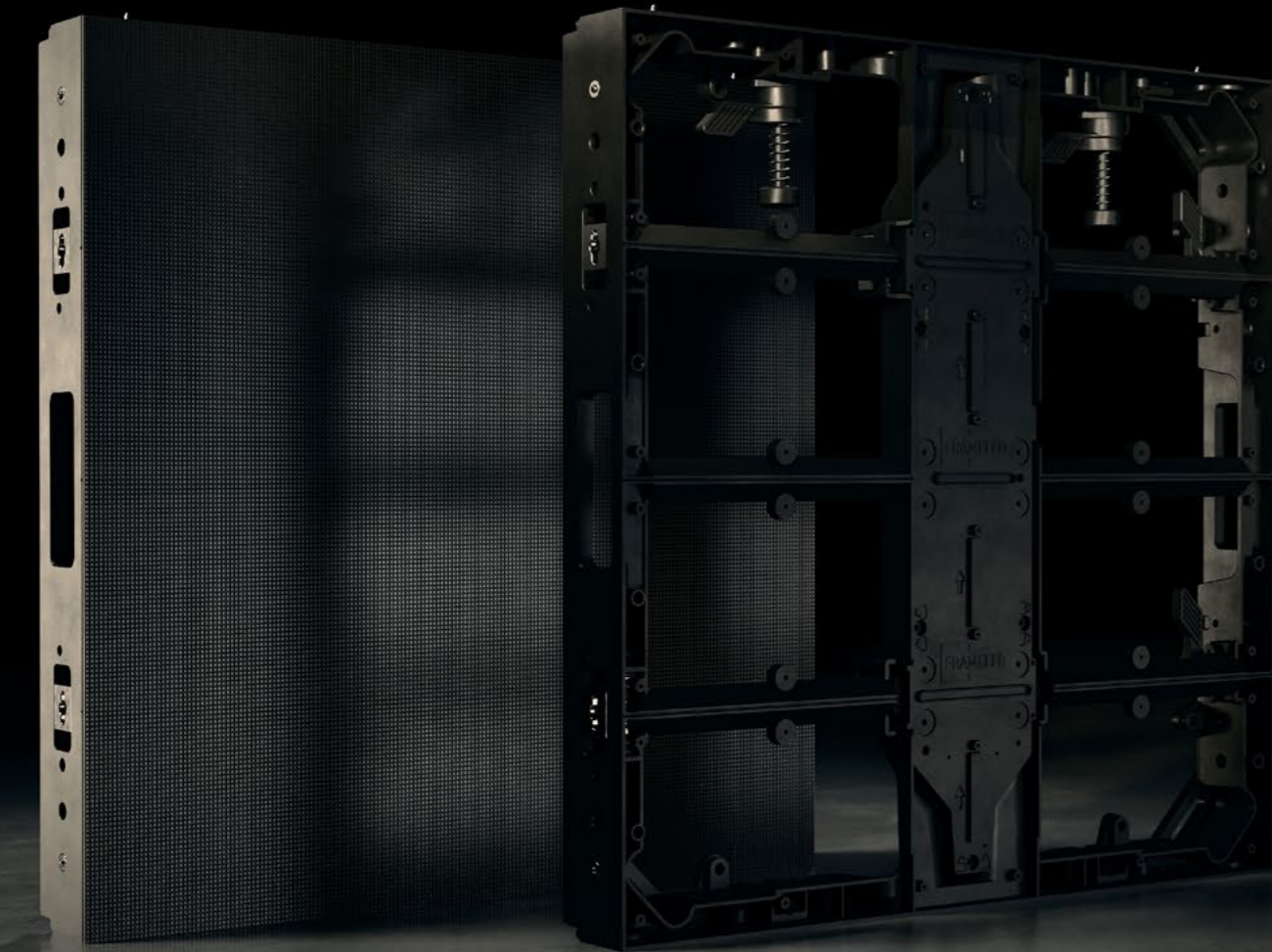



A 496mm LED cabinet,  
designed to fit 62mm  
standbuilding  
frame systems.

FRAMELED Versa offers a high quality LED display solution for a wide range of applications, from standbuilding and VR or XR studios to corporate events, film, television and broadcast.

### 1 module fits all

The FRAMELED Versa system is infinitely expandable and replaceable with different pixel pitches, due to its *1 module fits all principle*. From standard builds to creative cabinets like 90° corner and QT, every module works with every frame. It's as simple as that.

### Lightweight cabinets

Coming in at just 6.8 kg including the GOB, FRAMELED Versa opens up new design possibilities without compromising structural strength. Lightweight cabinets not only save valuable weight in transportation, but also allow for more creative freedom, larger surfaces and flexible rigging solutions with lower load impact.

### Full front service

All FRAMELED Versa cabinets are fully front serviceable without dismantling for quick maintenance and fast troubleshooting. Modules are easily swapped to ensure uninterrupted production flow. If advanced technical care is ever needed, our dedicated in house repair center is fully equipped to provide maintenance service.

### Controlled by VMP software

All FRAMELED Versa cabinets are equipped with NovaStar A10s Pro receiving cards by default to create stunning visual experiences. When paired with the flagship MX Series controller, an incredibly professional LED solution is realized, providing stunning image quality, precise color adjustment, and an intuitive software experience.

### FTP (front treatment protection)

Aside from safeguarding the LEDs for incidental impact and potential damage, the front treatment protection also boasts an impressive 160° viewing angle, ideal for television studios and broadcast. The black ink process provides deeper blacks and a higher contrast ratio, while the smooth surface is easy to clean with a microfiber towel. The total added weight of the coating is limited to just 600 g.

### Design with ease

Create your setups in Vectorworks and other leading CAD platforms. Simply integrate into your workflow and bring your stage, event or architectural concepts to life with precision and creativity.

# A closer look at the cabinet design.

FRAMELED Versa is designed with precision, flexibility and ease of use in mind, allowing technicians to work faster and build more accurately.

Magnetic installation guiding and pin alignment (removable)

Spring lock for fast installation

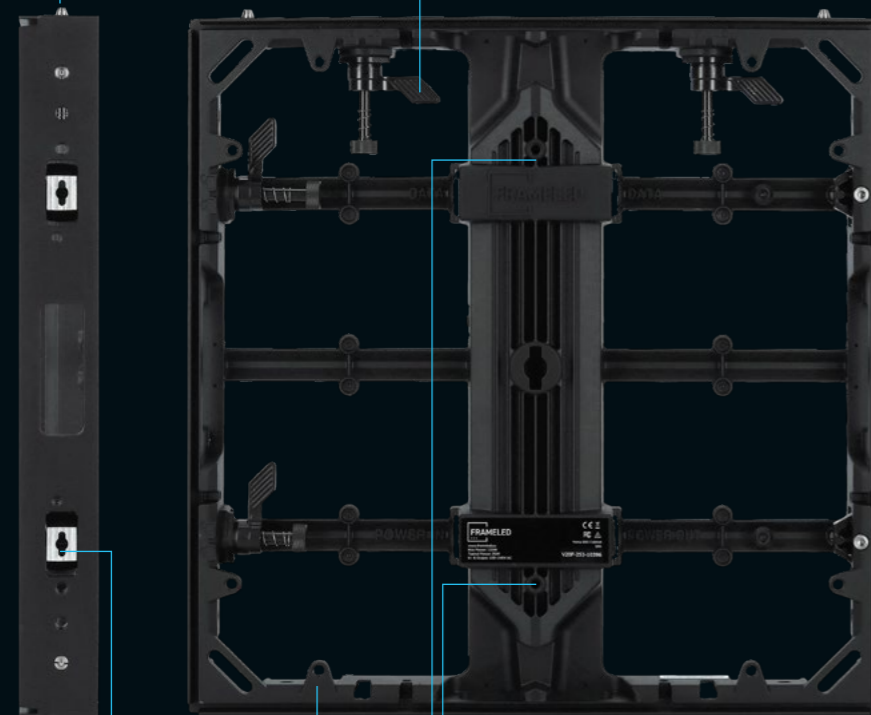

Integrated SEG slot

Integrated mechanism for concave LED 2.5° & 5° setup

Multiple M8/ M6 frame connections

## Modules available in different pixel pitches.

Match resolution to viewing distance, application and budget for optimal image quality without compromise.

□ 1,5   □ 2,0   □ 2,5   □ 2,5 XR/VR   □ 2,9



# Creative cabinets

The creative cabinet range of FRAMELED Versa opens up endless design possibilities. Versa Perfect Corner is built for seamless 90° corners and custom angles, while Versa QT allows you to adjust the aspect ratio with quarter-sized cabinets. Versa Flex unlocks even more creative freedom in your setups, with curves ranging from subtle bends to full 360° shapes.

All creative cabinets are fully compatible with both each other and the base cabinet, and support modules in 1.5 mm, 2.0 mm, 2.5 mm and 2.9 mm pixel pitch.



VERSA PERFECT CORNER  
496 x 496 x 62 mm (WxHxD)

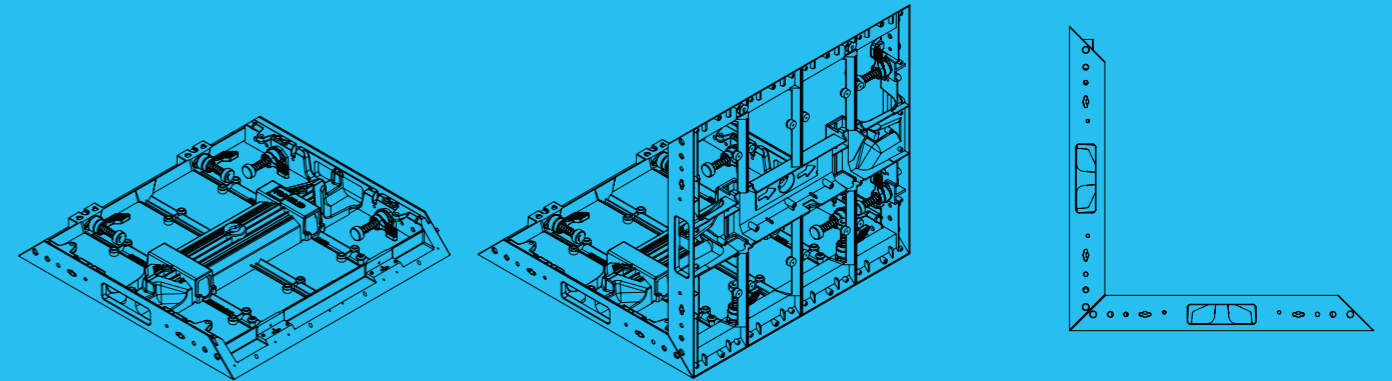
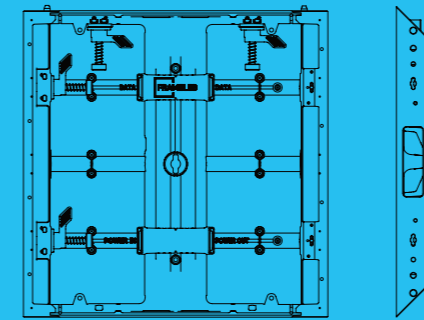

VERSA QT  
496 x 124 x 62 mm (WxHxD)

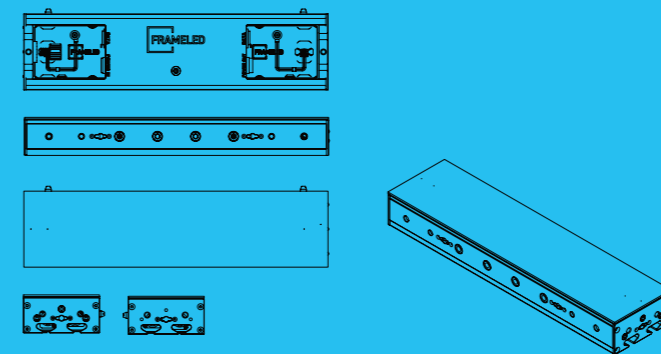

VERSA FLEX  
496 x 496 x 90 mm (WxHxD)

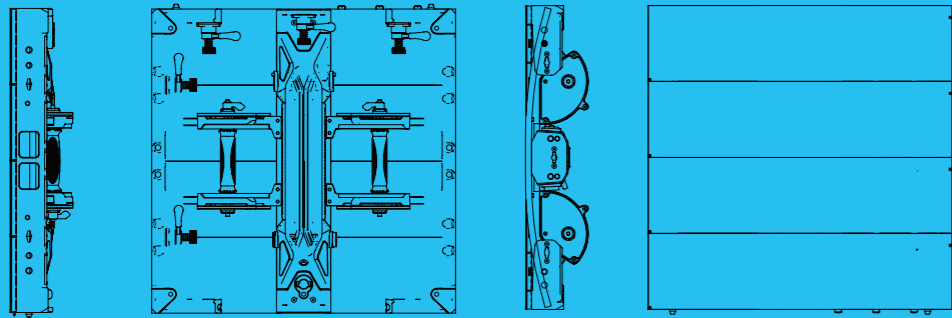

#### CREATIVE INSTALLATION



ONLY 8 CABINETS



ONLY 2 CABINETS



ONLY 8 CABINETS



ONLY 6 CABINETS

# Bend the rules with Versa Flex

Pair Versa Flex with other creative cabinets to design beyond conventional LED shapes, blending straight walls, sharp corners and organic shapes seamlessly together.

With just one cabinet, Versa Flex enables both convex and concave 45° curves, while only 2 cabinets are needed to create a 90° angle and a full circle can be achieved with just 8 cabinets.

Despite its flexibility, the cabinet remains lightweight at only 8.5 kg. Spring locks and adjustable turning handles ensure fast assembly and accurate mechanical alignment, making the system not only flexible in shape, but also in use.

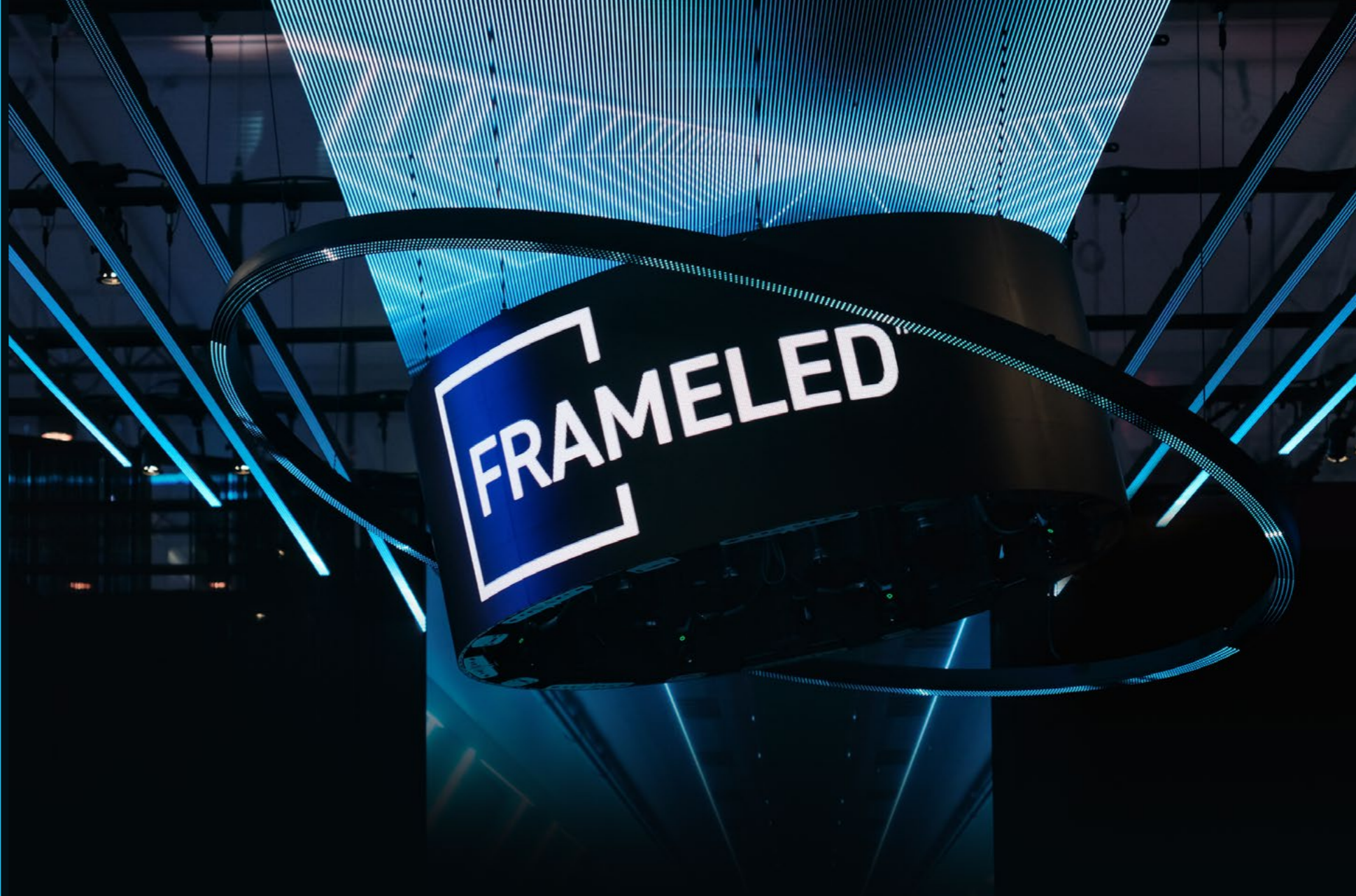

# Stacking and rigging has never been this easy

From floor-based constructions to overhead installations, FRAMELED Versa turns stacking and rigging into a breeze. The tool-free rigging beam makes assembly fast and straightforward, while the stacking beam provides a stable base for floor-stacking and compatibility with matrix frames for added stability. Paired with the perfect corner horizontal brace, Versa is built to keep every inch of the setup rock solid from the ground up.



Working with 62mm standbuilding frame systems? FRAMELED Versa fits right in, allowing LED to become a structural element of the booth rather than an add-on.





## RIGGING

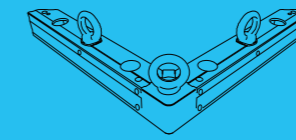

PERFECT CORNER RIGGING BEAM



PERFECT CORNER BRACE

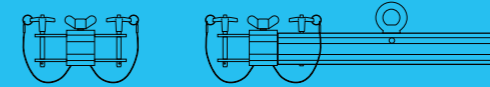

BEAM COUPLER



RIGGING BEAM 1 CABINET - Weight 2.5 kg - Max load 300 kg



RIGGING BEAM 2 CABINETS - Weight 5.5 kg - Max load 600 kg



RIGGING BEAM 3 CABINETS - Weight 8 kg - Max load 900 kg



RIGGING BEAM 4 CABINETS - Weight 10.5 kg - Max load 1200 kg

## STACKING



STACKING BEAM 1 CABINET



STACKING BEAM 2 CABINETS

# Behind the screen, LED driver ICs decide what you capture

## Macroblock Led driver

Powered by advanced driver technology from Macroblock, FRAMELED Versa delivers exceptional image quality even at low brightness levels. The MBS7253 driver ensures best in class low gray performance and features X Frame low gray refresh technology for smooth gradients and flicker free output, making Versa your go-to LED solution for camera based environments.



No More Flickers



No More Black Bands

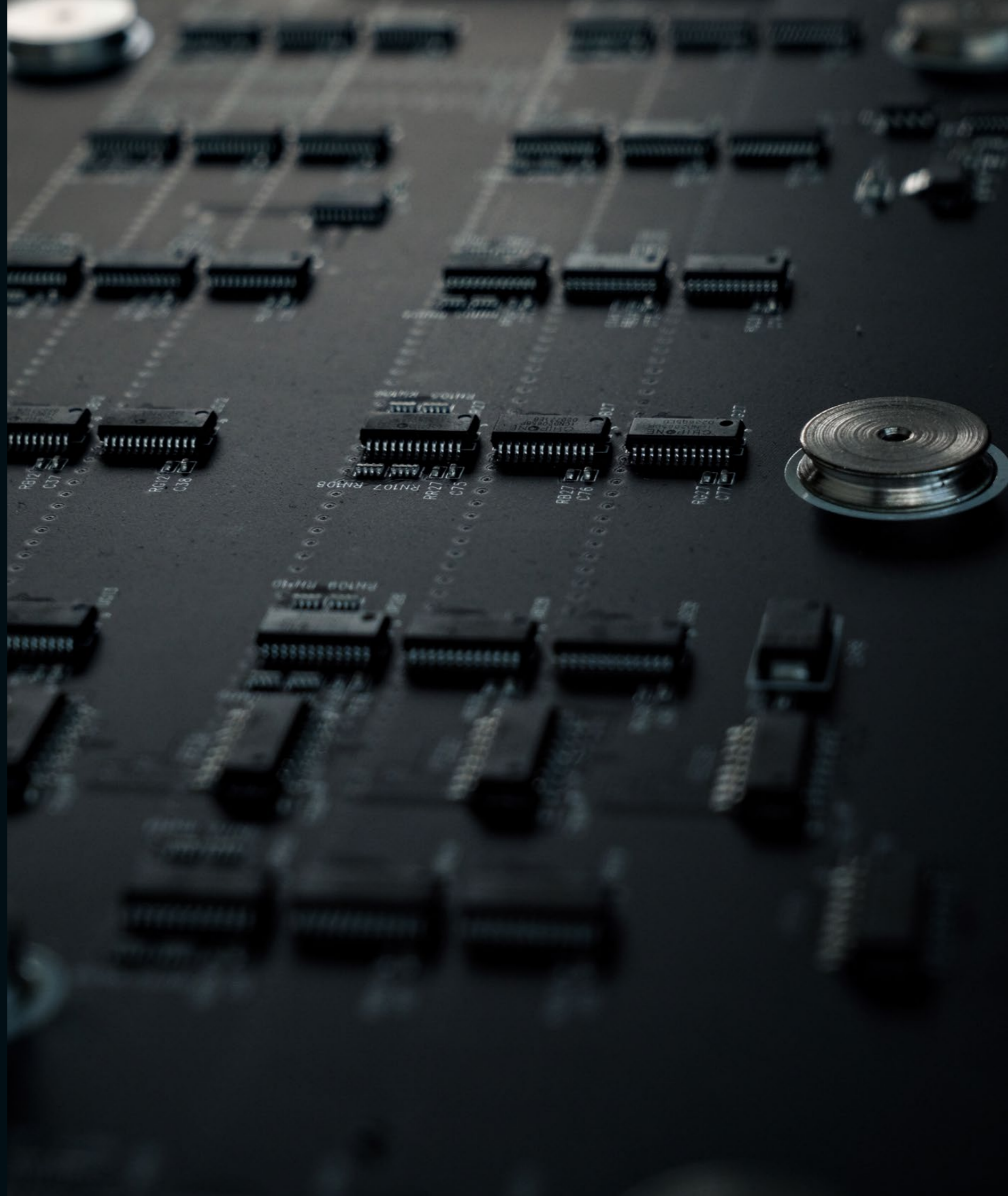



# Built for the road

A professional flightcase built with robust Penn Elcom hardware is available to protect FRAMELED Versa during intensive rental and touring logistics, featuring a fully customizable exterior and a tailored interior with integrated spacers for organized adapter storage.

120 kg - 1000x750x600 mm (WxHxD)



# Become a **FRAMELED** partner

Join our growing network of distributors and rental partners and get access to a versatile LED ecosystem designed for creative freedom, technical reliability and scalable growth.

Find your nearest distributor

[www.frameled.eu/partners](http://www.frameled.eu/partners)



More info & downloads

[www.frameled.eu/versa](http://www.frameled.eu/versa)

