

MBS
Architectural

Studco Design & Installation Manual
VOLUME 3.2



Contact the team for pricing & samples

hello@mbsarchitectural.com.au 03 9580 7800

Studco Australia Pty Ltd

ABN 39 145 053 925

STUDCO HEAD OFFICE

Suite 2-5 120 Beresford Rd, Lilydale Vic 3140

Phone: (03) 9737 2500 Fax: (03) 9737 2555

INDEX

<i>Introduction</i>	2
<i>Quality Assurance</i>	3
<i>Standards</i>	3
<i>Warranty</i>	4
<i>Certification</i>	5

Concealed Ceiling Systems	6-25
--------------------------------------------	-------------

Sound Isolation Systems	26-31
------------------------------------------	--------------

Steel Stud Systems	32-63
-------------------------------------	--------------

Top Hat & Cladding Sections	64-71
--------------------------------------------------	--------------

Ezy Finishing Sections	72-76
-----------------------------------------	--------------

GENERAL

The information and design tables contained in this manual are for the design of steel stud framed walls and ceiling systems and can be used for the selection of appropriate sections to be used in external or internal load bearing or non load bearing applications in residential, commercial or industrial buildings.

This manual does not include fire or sound acoustic ratings. These are covered by various building board manufacturer's specifications and individual tests.

All available sections are manufactured from high quality hot dipped zinc coated steel accurately roll formed to the specified dimensions to provide a consistent, reliable framing material for a range of applications including wall, ceiling and roof framing, bulkheads, fascias and many other applications.

Zinc coated steel is light and easy to handle and fix, has reasonable corrosion protection and is immune from biological attack in all its forms. Where severe corrosive conditions prevail, extra precautions will be required to ensure the life of the product. Consult Studco Building Systems under these circumstances.

All material supplied is accurately cut to specified lengths eliminating the necessity for site cutting. Wall Studs are supplied with 25mm diameter flared holes at approximately 600 centres for the installation of electrical and hydraulic services, thus minimizing on site labor for all sub trades.

DISCLAIMER

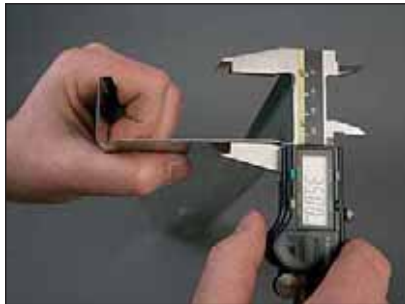
The information, charts and tables included in this manual have been prepared for use of Studco and their customers and clients and relate to the products manufactured by Studco. The information can not be assumed to apply to similar products of other manufacturers.

Any mixing of different manufacturer's products within a system will void all Guarantees. Studco Australia Pty Ltd will not be responsible for the structural performance of any structure designed using these tables and applied to products not manufactured by Studco Australia Pty Ltd. Any specifications and design criteria should be confirmed by the project engineer prior to installation.

This design manual is not to be reproduced in any form without written permission from Studco Australia Pty Ltd. Information printed in this document or communicated by the manufacturers, distributors or any agent is subject to change without notice. Studco Australia Pty Ltd will accept no liability for the accuracy of information supplied. Whilst every care has been taken in the preparation of this design and installation manual, Studco Australia Pty Ltd expressly disclaims all liability to any person of any product specifications or details set out in this design and installation manual, or otherwise in respect of anything done or omitted to be done, by any such person in reliance, whether in whole or in part upon the whole or part of the information set out within.

STUDCO BUILDING SYSTEMS have been certified to the ISO 9001:2008 Quality System and the ISO 14001:2004 Environmental Management System.

***Your quality is assured because
we are a certified company***



STANDARDS

The design tables, section properties, installation details and test data contained within this design and installation manual have been formulated in accordance with the following Australian, New Zealand and International standards.

AS/NZS 4600:2005

Cold formed steel structures

AS/NZS 1170:2002

Structural design actions
Part 0: General principles
Part 1: Permanent, imposed and other actions
Part 2: Wind actions;

Building Code of Australia (BCA 2009)

Volume 1 Section B Structure
Volume 2 Section 2.1 Structure

AS/NZS 2785:2000

Suspended Ceilings – Design & Installation

The products and systems manufactured by Studco Building Systems are warranted to be free from defects in material and workmanship if installed in accordance with Studco's recommendations and Building Board manufacturer's recommendations.

("the Customer")

TO: _____
PROJECT: _____
DATE: _____
WARRANTY REFERENCE NO: _____

Warranty

Studco Building Systems Pty Ltd ("Studco") warrants that all components manufactured by Studco for use in the Studco wall and ceiling components ("the Studco System")

- are designed and conform to Australian Standards -
 - AS 1397 Steel Sheet and Strip - Hot dipped zinc-coated and aluminium/zinc-coated
 - AS 4600/1538 Cold Formed Steel Structures Code
 - AS 1170.1 Loading Code - Dead and Live Loads
 - AS 1170.2 Loading Code - Wind Forces
 - AS 1250 Steel Structure Code
 - AS 4100 Steel Structures - Design and Installation
 - AS 2785 Suspended Ceiling Design and Installation
- are free from defects in material and workmanship.
- If any time period is specified in the date of this warranty when the Studco System is designed and installed in accordance with the Studco Design and Installation Manual and Building Board manufacturer's recommendation if any Studco System component fails to meet these warranties Studco shall at its sole discretion either (subject to any applicable law):
 - substitute the defective component; or
 - provide an equivalent substituted component; or
 - fix the defective components or pay the cost of fixing those components; or
 - pay the cost of substituting the defective component or of acquiring the equivalent substituted components.

But Studco shall not be liable for any special consequential direct or indirect loss or damage or harm or injury suffered as a result of such defect to the extent permitted by law of the Customer or any person claiming through the Customer.

The Customer acknowledges that the steel material is not manufactured by Studco the warranty of the manufacturer of the material (if any) shall be accepted by the Customer and is the only guarantee given to the Customer in respect of the material.

This Warranty shall be invalidated by Studco where:

- installation of the Studco System component is not in accordance with Studco's recommendations, installation or specifications as published and directed at the time of the warranty; or
- the Studco System components are installed in locations exposed to moisture, humidity or corrosion or corrosive material or other destructive substances; or
- the Studco System incorporated any components not manufactured or approved by Studco; or
- Studco has not been paid in full for the Studco System components supplied; or
- any variation, alterations or additions have been made to the Studco System which have not been approved in writing by Studco; or
- the Studco System has not received maltreatment, inattention or interference; or
- the defect has not arisen solely from faulty material or workmanship; or
- there has been inadequate or improper maintenance of the Studco System; or
- there has been inadequate or implied warranties, guarantees and conditions under Statute or general law as to merchantability, description, quality, suitability or fitness of the Studco System for any purpose or as to the design, assembly, installation or material or workmanship or otherwise are hereby expressed excluded to the full extent permitted by law and Studco shall not be liable for any physical or financial injury, loss or damage or for any consequential loss or damage of any kind arising out of the supply and layout, assembly, installation or operation of the Studco System in any way whatsoever.

Executed by an authorised person of the Customer: _____ Dated: _____
Name: _____ Position: _____

R.E.Proud & Associates Pty. Ltd.
Civil and Structural Engineers
Ballarat and Tasmania

14 Victoria St, Ballarat, 3350
P.O.Box 2125 Bakery Hill, Vic, 3354
Ph: 03 5327 7477 Fax 03 5327 7488
Email: rpa@meridianalliance.com.au



Civil & Structural Engineers, Surveyors and Planners

Level 2, 45 - 47 Rooke St, Devonport, 7310
P.O.Box 752 Devonport, Tas, 7310
Ph: 03 6424 1611 Fax: 03 6423 1131
Email: meridian_tas@bigpond.com

18-June-2009

To Whom it may Concern

This is to certify that the Various tables, charts and section properties for cold formed steel sections for steel wall and ceiling framing systems presented in the STUDCO Design Manual have been prepared by the undersigned in accordance with the provisions of the the following Australian Standard Codes (Subject to conditions and limitations stated therein).

BUILDING CODE OF AUSTRALIA 2009			
Volume 1 Section B Structure			
Volume 2 Section 2.1 Structure			
AS/NZS 1170			Structural Design Actions
	Part 0	2002	General Principals
	Part 1	2002	Permenant, imposed and other
	Part 2	2002	Wind Actions
AS/NZS 1170			Minimum Design Loads on Structures
	Part 1	1989	Dead and Live Loads and load Combinations Incl Amdt 1 Jan 1993
	Part 2	2002	Wind Loads Amdt 1 Amdt 2 Amdt 3
AS 4100 - 1998			Steel Structures Code
AS/NZS 4600 - 2005			Cold Formed Steel Structures code
AS 4055 - 2006			Wind Loads for Housing



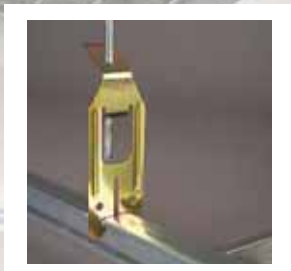
Ross Proud
Dip CE MIEAust, CPENG
NPER 78086
Registered Building Practitioner State registrations
Victoria EC1039
Queensland RPEQ 7601
Tasmania CC1406U
Northern Territory 56121 ES

Concealed Ceiling Systems



M27R Top Cross Rail

Can be rolled to create curved ceilings.



M534 Spring Hanger

Used for suspension of concealed ceiling systems



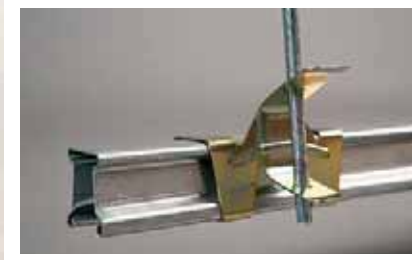
MBF Betafix Clip

For adjustment when fixing furring channel



M39 Locking Key

Primary coupling with unique thumb push tab providing ease of installation.



M520 Side Mount Spring Hanger

TCR suspension clip ideal for use in confined areas.



M534 Spring Hanger

With fixing holes for preliminary suspension of bulkheads and floating ceilings.

Concealed Ceiling Systems

The Studco Concealed Ceiling System is engineered to provide designers and installers with a flexible and secure system for a building board flush finish. Components are manufactured from galvanised steel, designed for safe handling, and easily clipped together to form gridwork where building boards can be simply fixed. Components such as battens, furring channels and top cross rail allows for a range of loading options and ceiling spans. Furring channel track reduces the need for suspended fixing at each end of the ceiling. For curved ceilings, top cross rail can be easily curved in either direction to various radii. Studco Concealed Ceiling Systems can be used for non-fire-rated or fire-rated applications and have been designed to meet the relevant Australian standards.

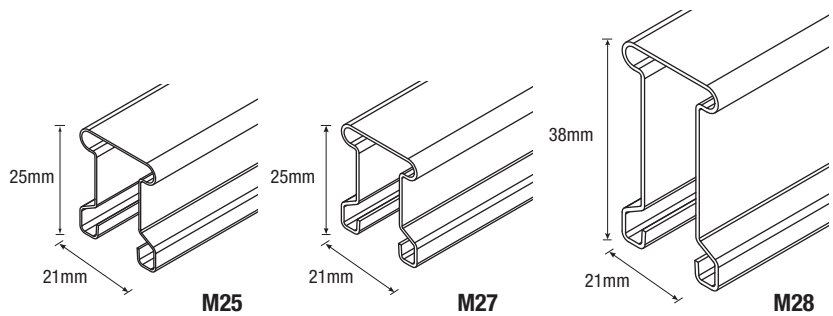
Components

Top Cross Rail

Table 1

PART No	DESCRIPTION
M25	25mm Top Cross Rail 0.55BMT
M27	25mm Top Cross Rail 0.75BMT *
M28	38mm Top Cross Rail 0.75BMT

* Available as a radius section



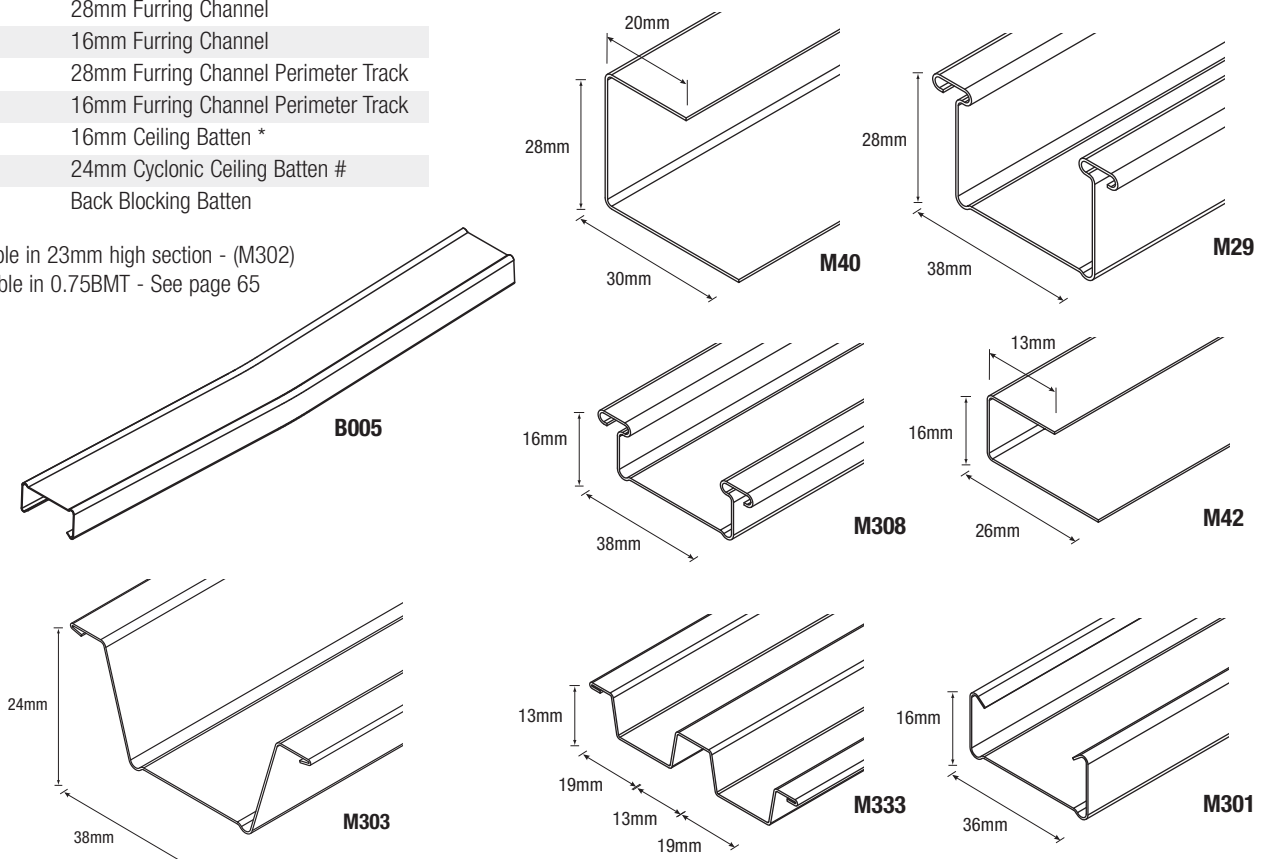
Furring Channel, Wall Track and Batten

Table 2

PART No	DESCRIPTION
M29	28mm Furring Channel
M308	16mm Furring Channel
M40	28mm Furring Channel Perimeter Track
M42	16mm Furring Channel Perimeter Track
M301	16mm Ceiling Batten *
M303	24mm Cyclonic Ceiling Batten #
B005	Back Blocking Batten

* Available in 23mm high section - (M302)

Available in 0.75BMT - See page 65

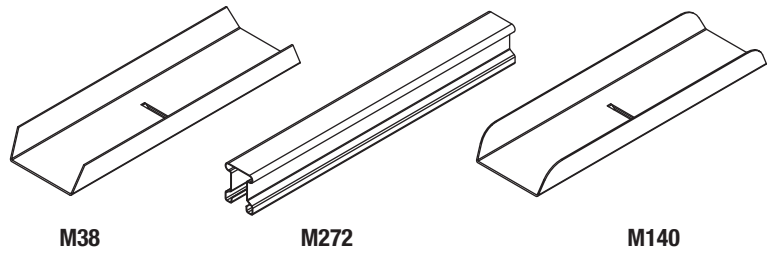


Concealed Ceiling Systems - Components

Section Joiners

Table 3

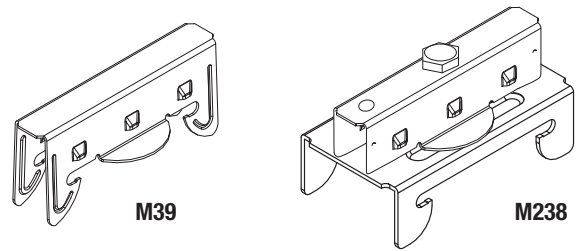
PART No	DESCRIPTION
M38	M29 Joiner
M272	M27/M25 Top Cross Joiner
M140	M301 Batten Joiner



Primary Couplings

Table 4

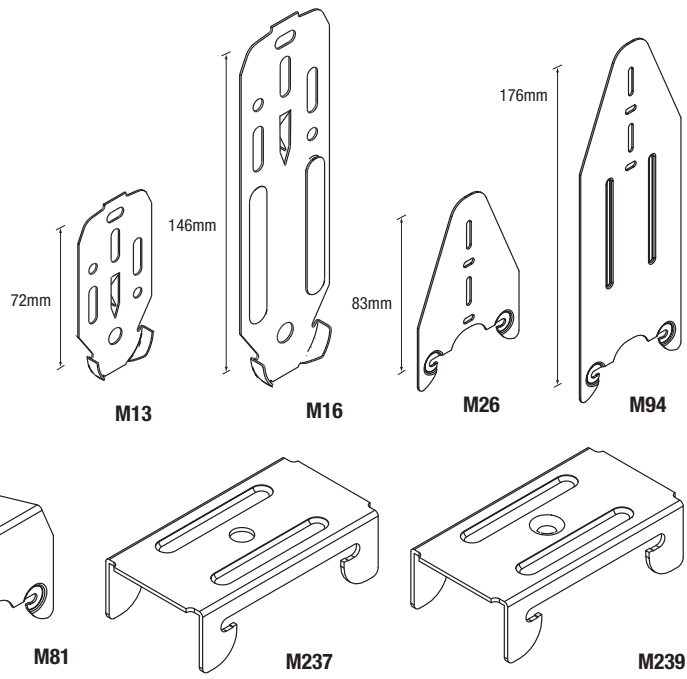
PART No	DESCRIPTION
M39	M29/M308 to M27/M28 Locking Key
M238	Swivel Locking Key



Direct Fix Clips

Table 5

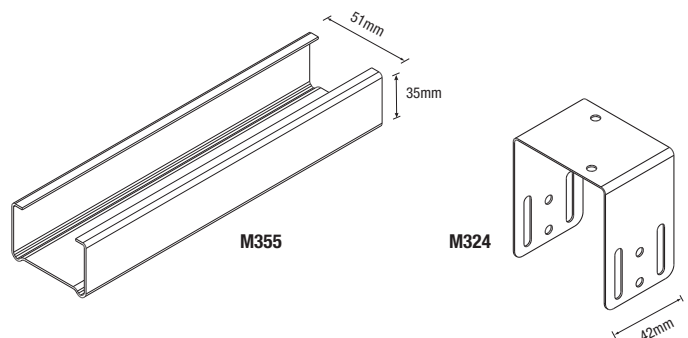
PART No	DESCRIPTION
M13	M301 Direct Fix Short
M16	M301 Direct Fix Long
M80	M301 Direct Fix Wall Clip
M26	M29/M308 Direct Fix Short
M94	M29/M308 Direct Fix Long
M81	M29/M308 Direct Fix Angle Bracket
M237	M29/M308 Wall Clip
M239	M29/M308 Wall Clip Threaded M6



Slimceil Components

Table 6

PART No	DESCRIPTION
M355	M355 Ceiling Channel 0.5mm
M324-2	Slimceil Ceiling Bracket 37-60mm *
M324-4	Slimceil Ceiling Bracket 52-75mm *
M324-6	Slimceil Ceiling Bracket 67-90mm *
M324-8	Slimceil Ceiling Bracket 82-105mm *



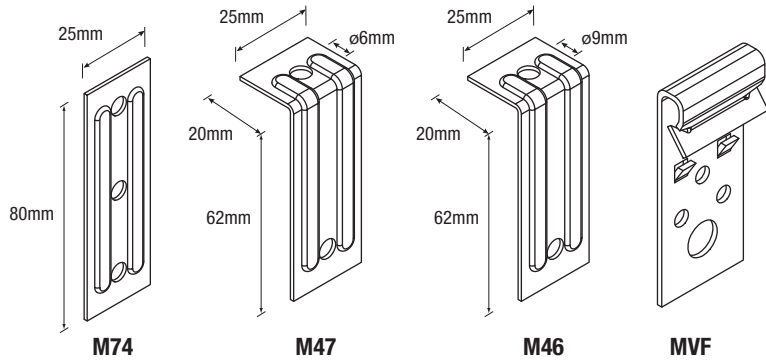
* Distance from concrete substrate to back face of plasterboard lining

Concealed Ceiling Systems - Components

Direct Fixing Clips

Table 7

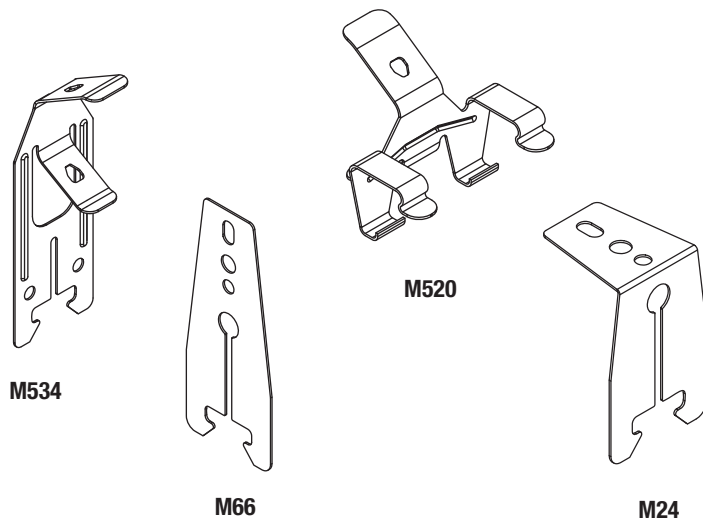
PART No	DESCRIPTION
M74	Rod Bracket
M47	Right Angle Rod Bracket
M46	Right Angle Rod Bracket
MVF	Purlin Clip



Primary Suspension Clips

Table 8

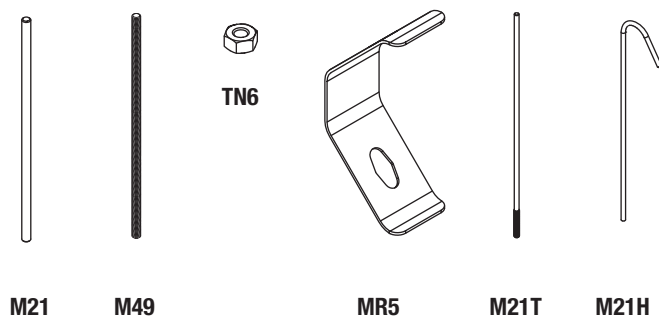
PART No	DESCRIPTION
M534	M27/M28 Spring Hanger
M520	M27 Side Mount Spring Hanger
M66	M27/M28 Direct Fix
M24	M27/M28 Direct Fix Right Angle



Suspension Rod

Table 9

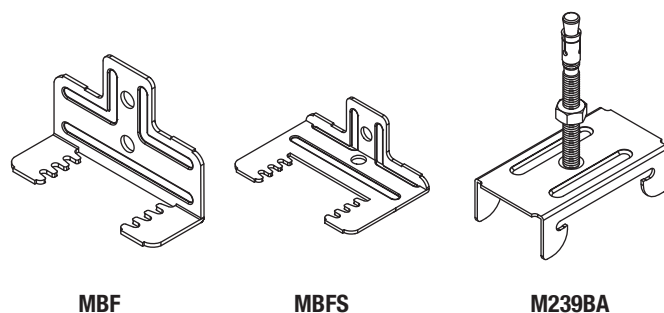
PART No	DESCRIPTION
M21	5mm Galvanized Rod
M49	6mm Threaded Rod
TN6	6mm Zinc Nuts
MR5	M21 Rod Joiner
M21T	5.2mm Galvanized Rod w/M6 Thread
M21H	5mm Galvanized Rod Hooked one end



Adjustable Clips

Table 10

PART No	DESCRIPTION
MBF	M29/M308 Adjustable Direct Fix
MBFS	M29/M308 Adjustable Direct Fix Long
M239BA	M29/M308 Direct Fix with Tru Bolt



Installation Guide - Direct Fix Ceilings

The Studco Concealed Ceiling System has a range of options for direct fixing of battens and furring channels in ceiling applications (as shown in Fig 1). The maximum ceiling drop should not exceed 180mm. A greater drop than 180mm requires the Studco Suspended Ceiling System. Direct Fixing clips must be fixed along the furring channel or batten sections in accordance with the relevant maximum ceiling span tables. A minimum of two fasteners must be used per clip. The temporary holding tab can be used as a non permanent fixing for ease of installation when fixing to timber beams. Also there must be a minimum clearance of 2mm to the underside of the joist (as shown in Fig 1). The Furring Channel or Batten sections should be spaced in accordance with the building board manufacturer's recommendations. It is not recommended to screw or nail fix battens or furring channels directly to a joist supporting a trafficable floor due to deflection of the joist occurring and possible subsequent interaction with the ceiling batten.

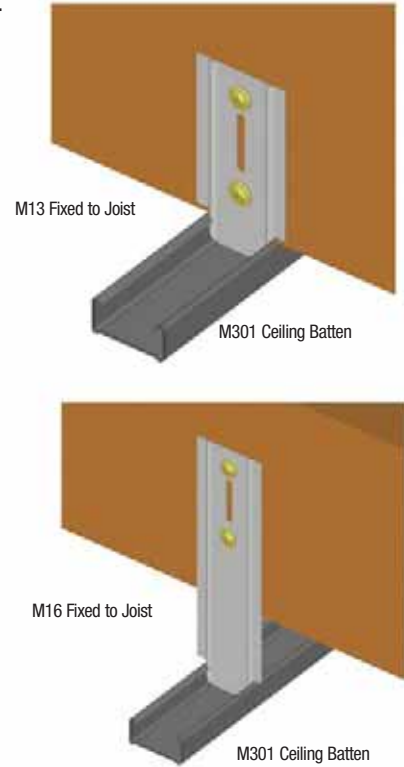
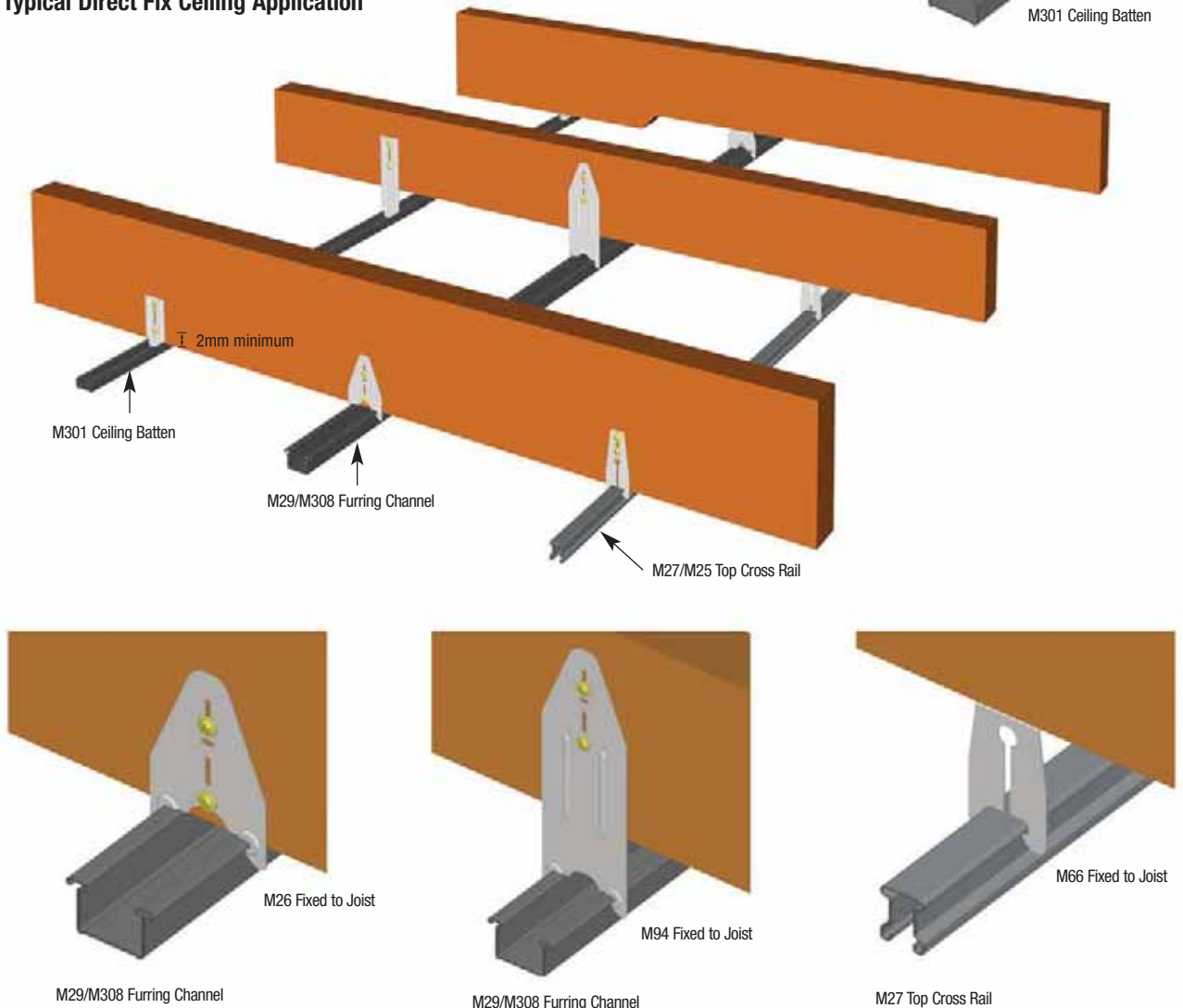


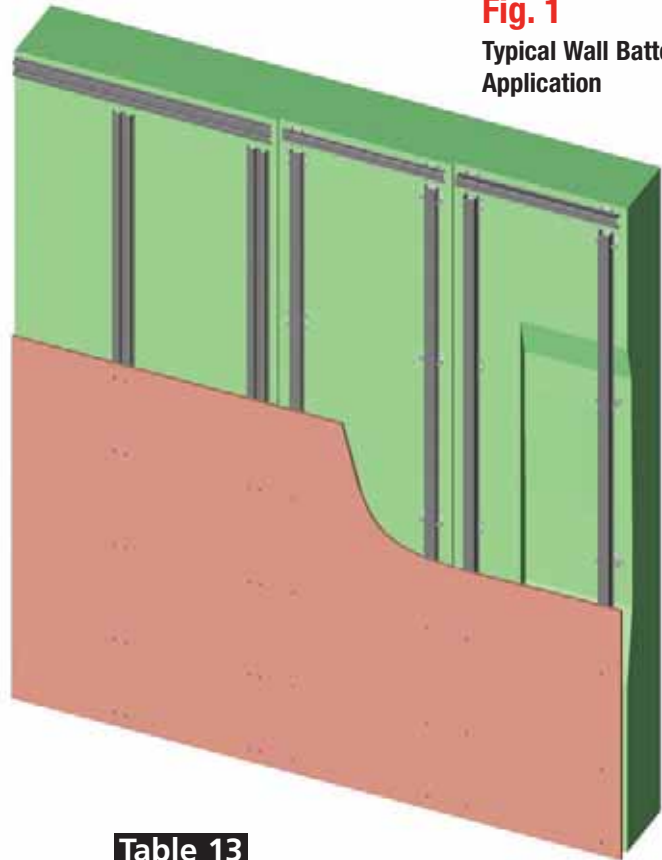
Fig. 1
Typical Direct Fix Ceiling Application



Installation Guide - Direct Fix Ceilings and Walls

The Studco furring channels and battens together with the range of direct fixing clips are the most effective way of battening out of irregular walls in preparation for the fixing of the building boards. A combination of direct fix and adjustable clips may be used. (See Fig. 1). Adjustable clips can offset irregular surfaces up to 50mm (as shown in Fig. 2). Anchors should be selected in accordance with the manufacturers recommendations. Anchors should be spaced in accordance with Table 12.

Fig. 1
Typical Wall Batten Application



Concealed Ceiling Systems

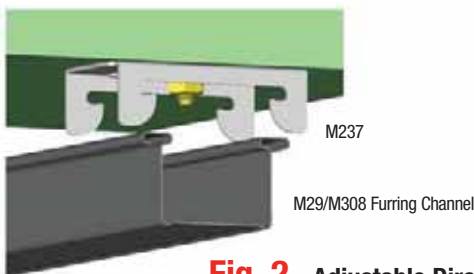
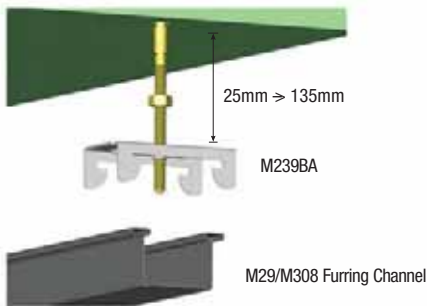


Fig. 2 Adjustable Direct Fix Clips - Wall Batten Application

Table 13

MAXIMUM ANCHOR SPACING	
FURRING CHANNEL	ANCHOR SPACING
M333 13mm Recessed Furring Channel	900mm
M29 28mm Furring Channel	1200mm
M308 16mm Furring Channel	900mm

Note: The above spacings may not be suitable for high traffic areas or external applications.

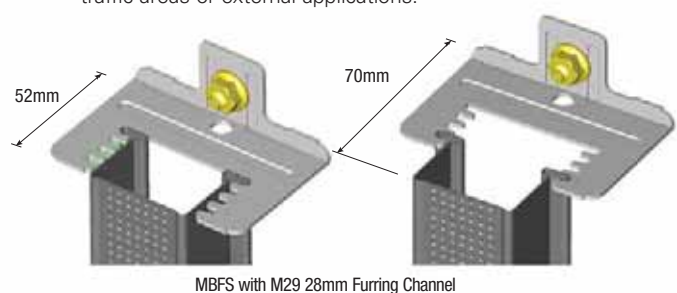
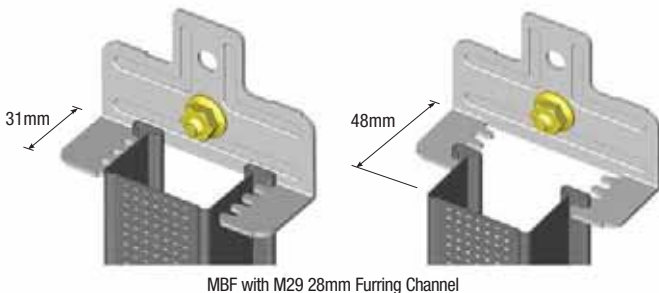


Table 11

MAXIMUM POSITION		
ADJUSTABLE DIRECT FIX CLIP	FURRING CHANNEL	MEASUREMENT rear of clip to face of furring channel
MBFS	M29 28mm Furring Channel	70mm
MBFS	M308 16mm Furring Channel	58mm
MBF	M29 28mm Furring Channel	48mm
MBF	M308 16mm Furring Channel	36mm

Table 12

MINIMUM POSITION		
ADJUSTABLE DIRECT FIX CLIP	FURRING CHANNEL	MEASUREMENT rear of clip to face of furring channel
MBF	M308 16mm Furring Channel	19mm
MBF	M29 28mm Furring Channel	31mm
MBFS	M308 16mm Furring Channel	40mm
MBFS	M29 28mm Furring Channel	52mm

Installation Guide - Suspended Ceilings

Concealed Ceiling Systems

Fig. 1 Furring Channel Joiner

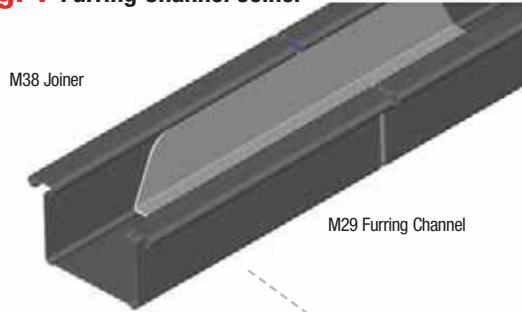


Fig. 2 Batten Joiner

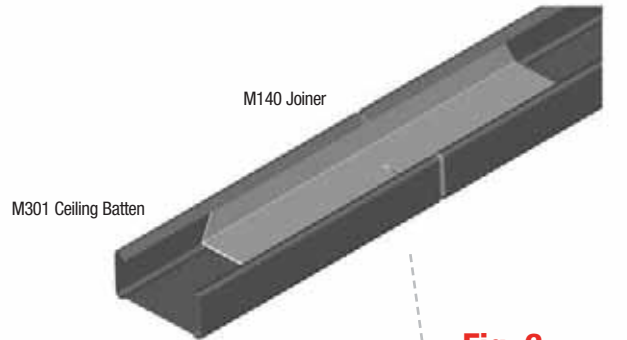


Fig. 7 Wall Track Fixing Detail

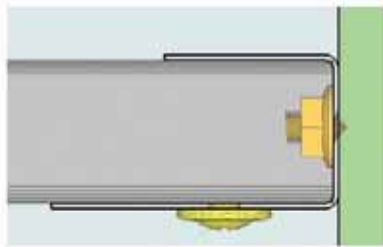


Fig. 6 Primary Channel Connection to Furring Channel

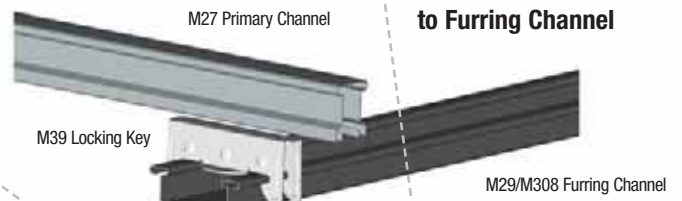
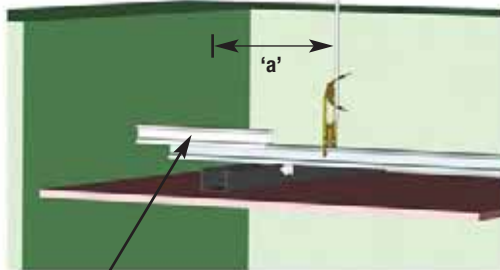


Fig. 8 Stabilising The System



M272 Joiner - At wallend for stability

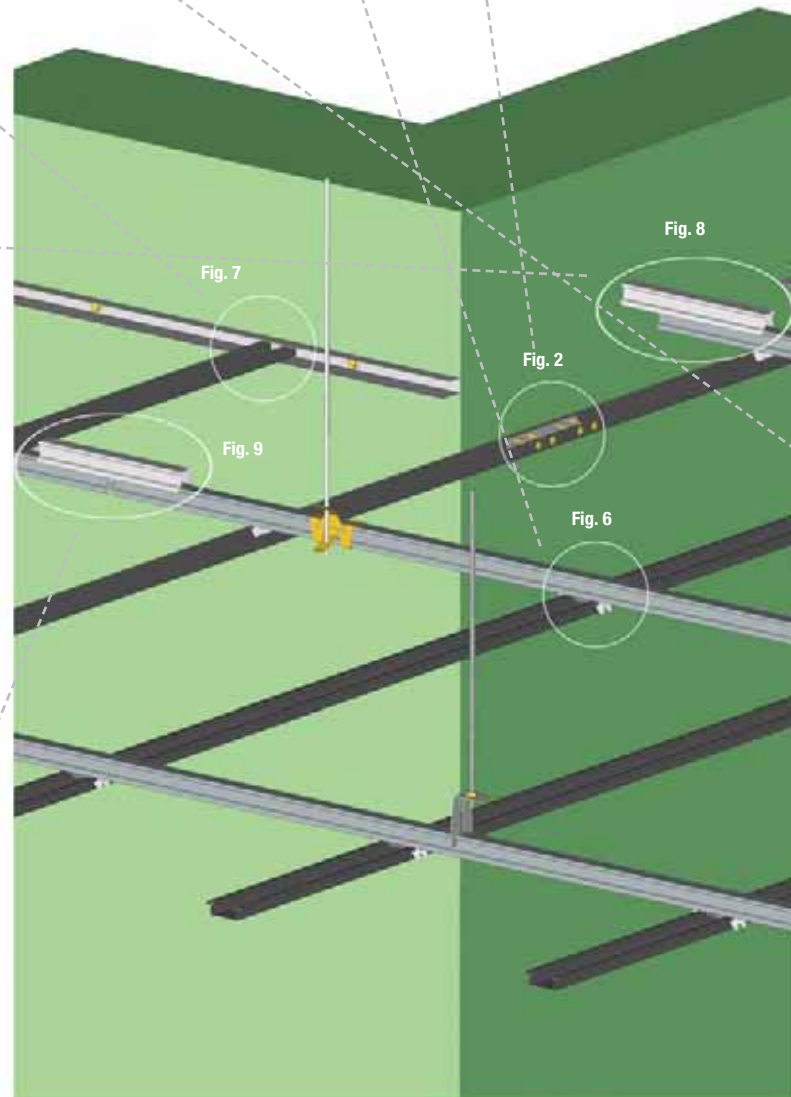


Table 14

FIRST HANGER POSITION	
TOP CROSS RAIL	'a' MAXIMUM
M25 25mm Top Cross Rail 0.55BMT	300mm
M27 25mm Top Cross Rail 0.75BMT	400mm
M28 38mm Top Cross Rail	400mm

* For one layer of plasterboard



Fig. 9 Top Cross Rail Joiner

Fig. 4 Top Cross Rail
Thread Adjustable Attachment



Fig. 3 Top Cross Rail
Adjustable Low Clearance Attachment

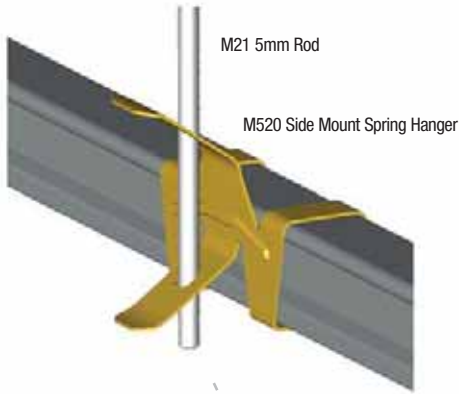


Fig. 5 Top Cross Rail Suspension Clip

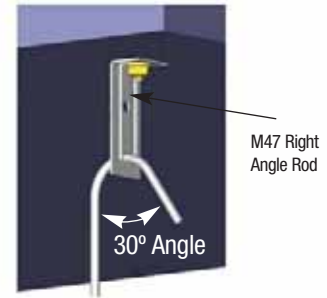
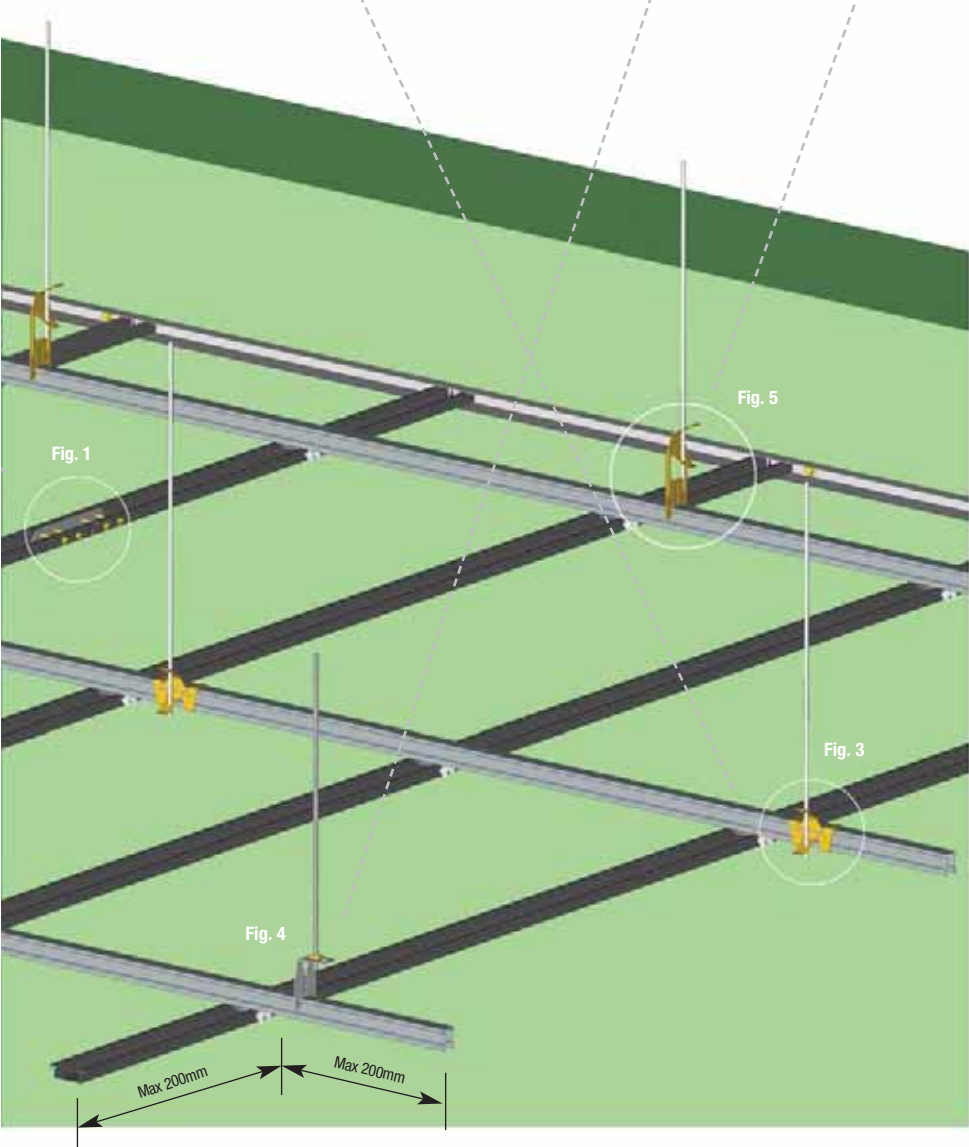


Fig. 10 Bracket Fixed to Concrete

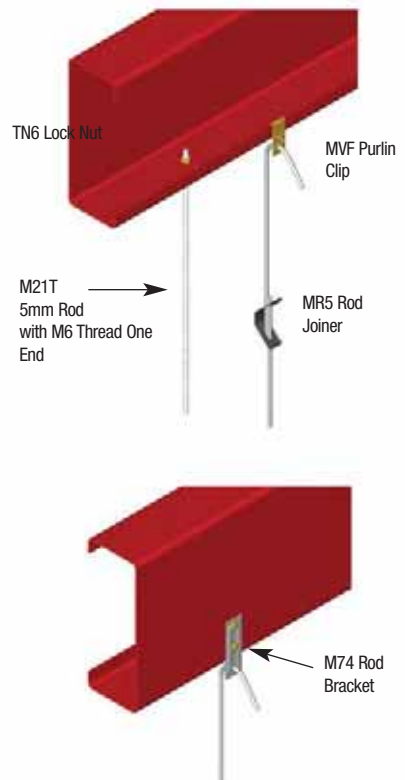


Fig. 11 Rod Suspension from Purlin

Installation Guide - Curved & Raked Ceilings

Concealed Ceiling Systems

Fig. 1
Curved Ceilings

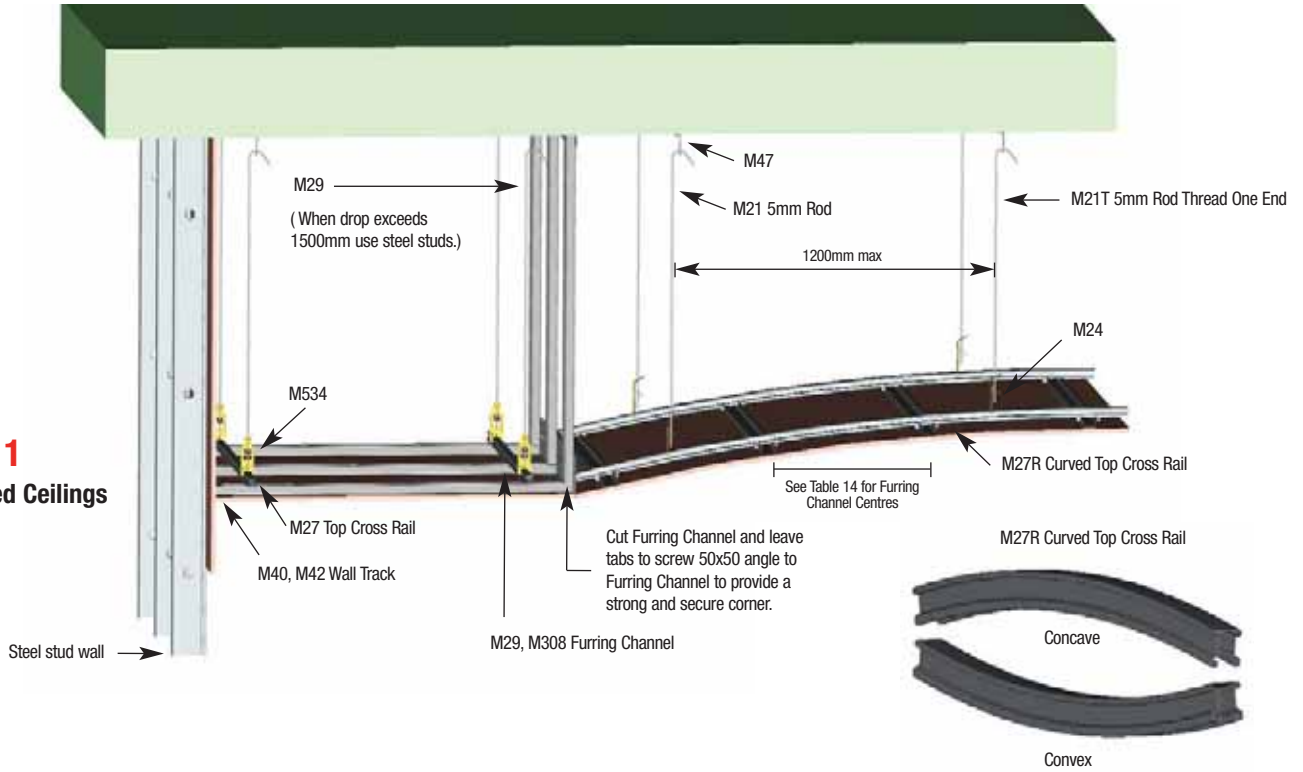


Table 15

FURRING CHANNEL CENTRES - CURVED CEILINGS							
PLASTERBOARD THICKNESS	CEILING RADIUS						
	900mm-1000mm	1000mm-1500mm	1500mm-2000mm	2000-2500mm	2500-3000mm	3000mm-4000mm	4000mm
	MAXIMUM FURRING CHANNEL CENTRES						
6.5mm	150mm	200mm	250mm	300mm	350mm	450mm	550mm
10mm	150mm	200mm	250mm	300mm	350mm	400mm	500mm
13mm	--	150mm	200mm	250mm	300mm	400mm	500mm
16mm	--	--	--	--	--	250mm	350mm

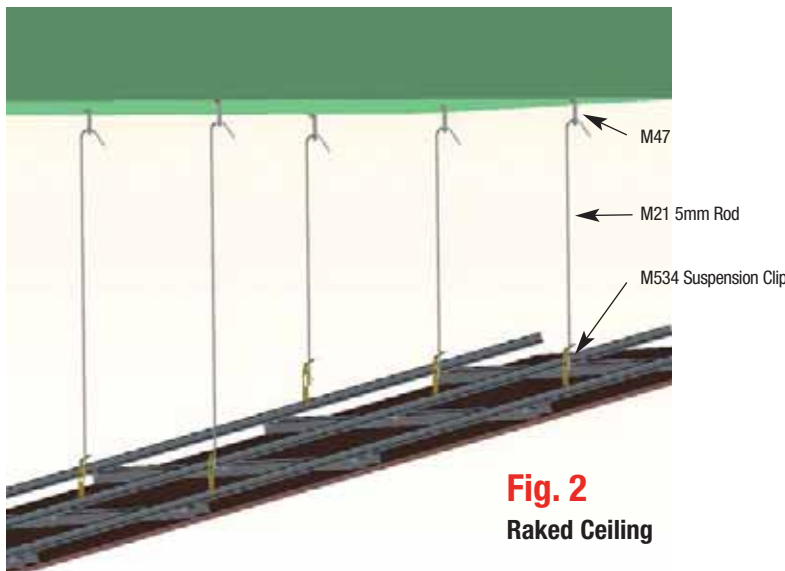
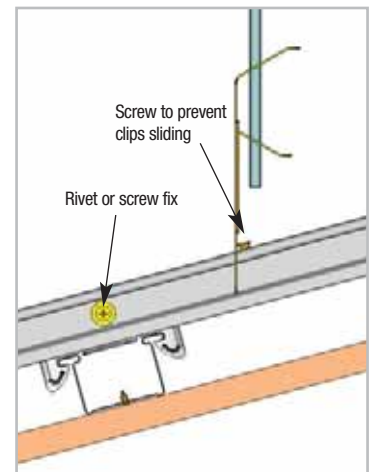


Fig. 2
Raked Ceiling



Installation Guide - External Suspended Ceilings

Certain components from Studco's Concealed Ceiling System are approved for installation in external applications, when due consideration is taken for external wind conditions.

You will need to first determine what is the design pressure of limit state for the ceiling location. This information needs to be determined by a suitable qualified engineer in accordance with AS/NZS1170.2 and AS/NZS 2785.

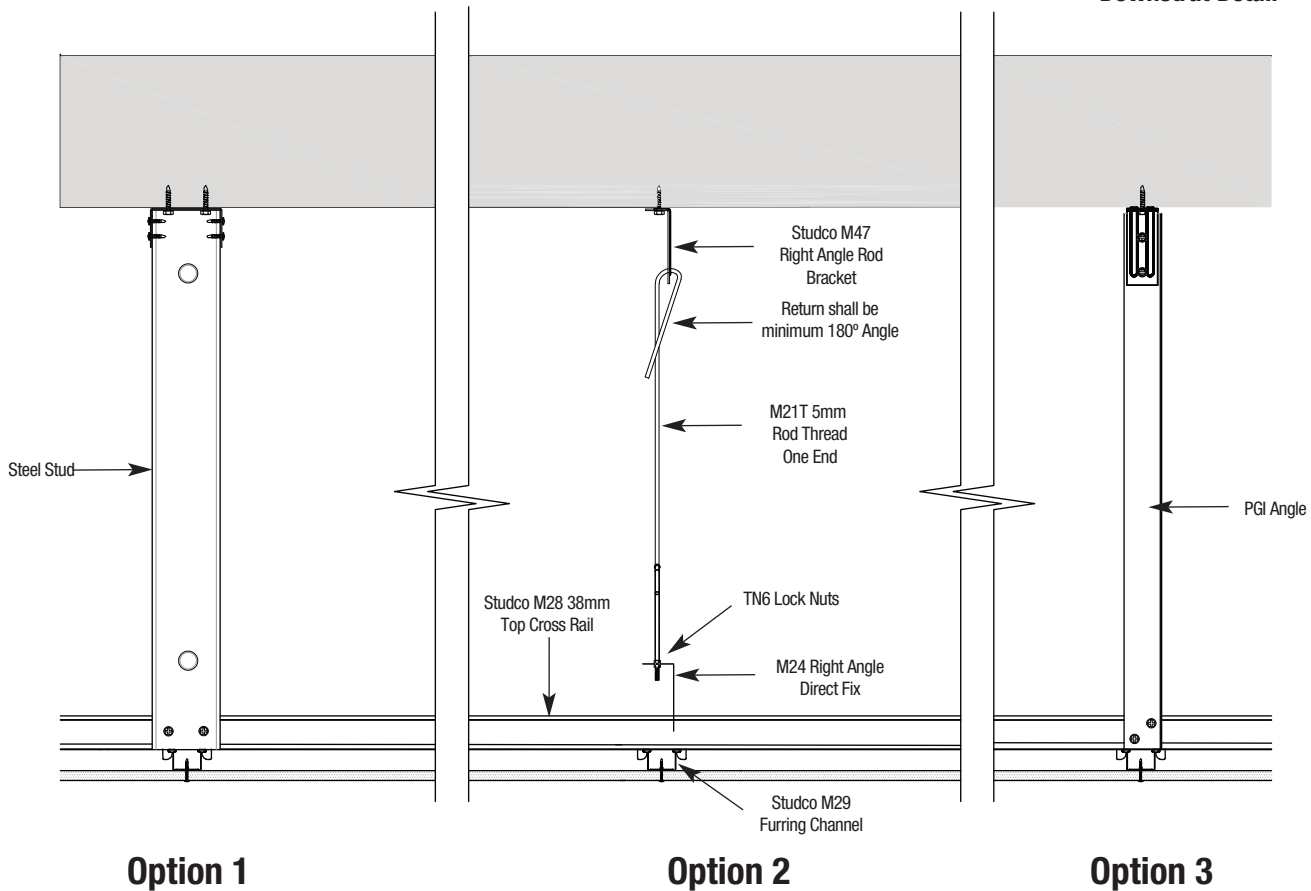
Suspending the ceiling system using a rigid down strut provides the necessary support against additional upward wind loads often experienced in external ceilings applications. Three different down strut options are shown in Fig 1. Additional options are available from Studco on request.

The recommended top cross rail profile for all external applications is Studco M28 top cross rail (38mm high x 0.75 BMT galvanized steel).

Adjustable friction-fit components, such as the Studco M534 and M520 spring hangers, are generally not suitable for use in external applications. The 25mm high top cross rail profiles, such as the Studco M25 and M27, should not be used in external applications either.

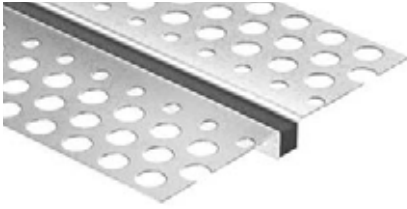
Please contact Studco technical team for external ceiling design specifications.

Fig. 1
Downstrut Detail

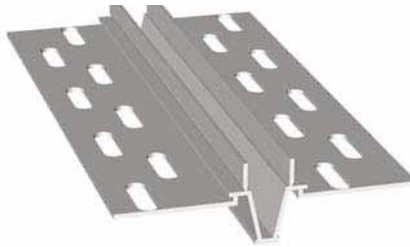


Installation Guide - Expansion Joints

Concealed Ceiling Systems



EJ06 Expansion Joint 6mm



PEJ93 PVC Expansion Joint with Zip Strip



PE127 PVC Hideaway Expansion Joint with Zip Strip

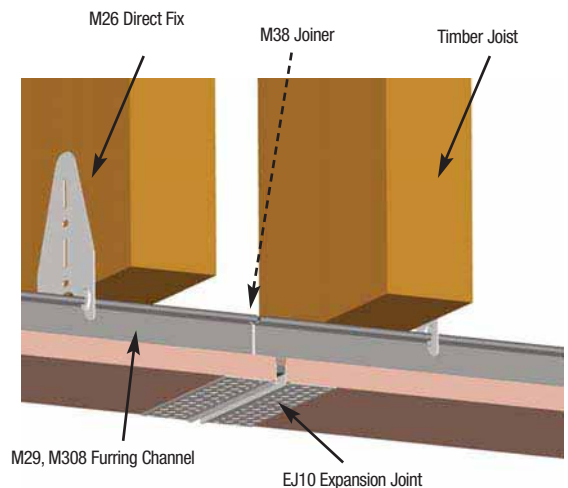
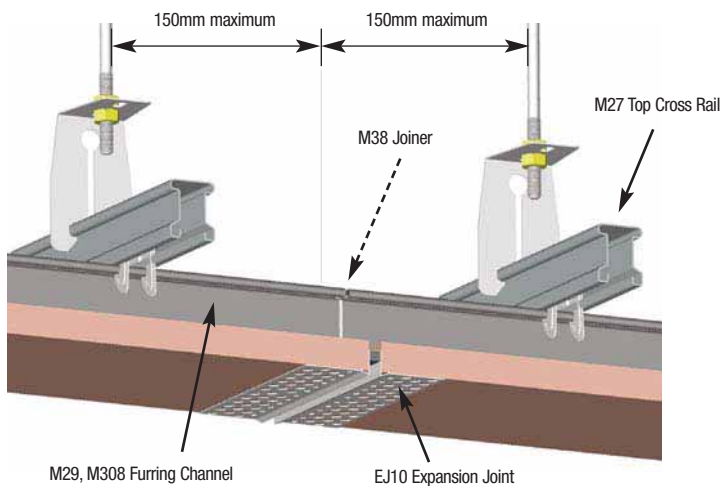
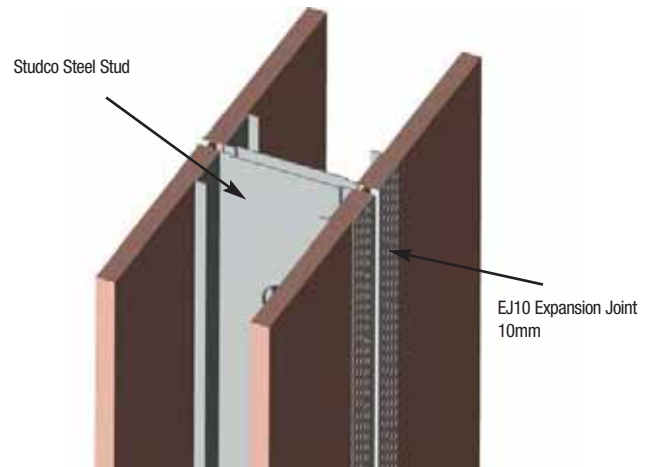


EJ10 Expansion Joint 10mm



EJ35 Expansion Joint 35mm

Expansion joints are required in walls and/or ceilings in order to accommodate movements in the building structure due to shrinkage, settlement, wind or seismic forces. Building board manufacturers recommend that expansion joints are required in unbroken walls and ceilings at no greater than 12 metre centres. The metal stopping bead on the Studco EJ06 and the EJ10 expansion joints are connected with a close cell neoprene sponge infill providing movement in all directions. These expansion joints also provide excellent acoustic isolation. Contact Studco Technical Services for more information.



Installation Guide - Slimceil



Concealed Ceiling Systems

The Studco SLIMCEIL ceiling system is a solution for compact ceiling cavities. The Studco SLIMCEIL Ceiling System consists of a C-channel section and a series of four brackets, designed to provide adjustable stand-off points for fixing the channel. The bracket range provides an overlapping series that covers ceiling cavities from 37mm through to 105mm. It's the simple, easy to install and fast answer to small ceiling cavities. Greater load strength can be achieved using the SLIMCEIL system, refer to table 18 for load ratings.

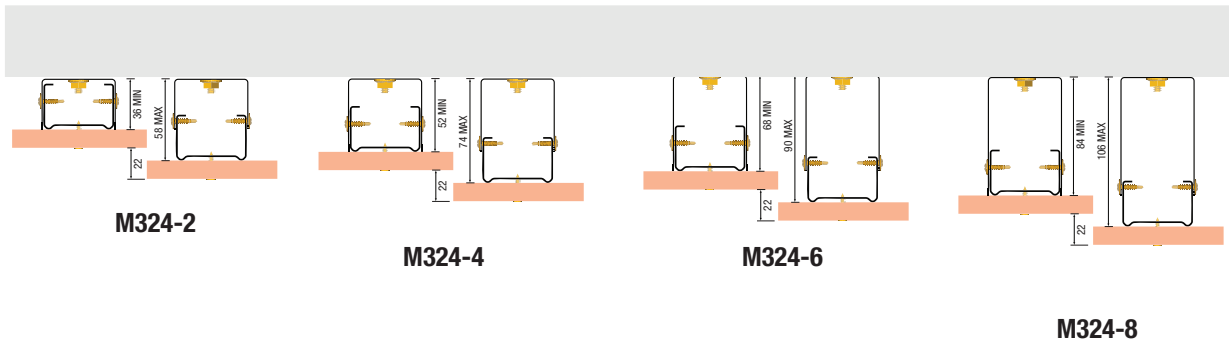
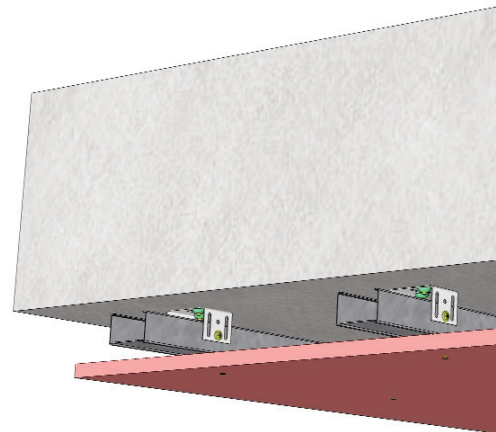


Table 17

Part No.	CEILING BRACKETS	Cavity dist. mm.	Approx kg/pce	Material Thickness	Material Grade
M324-2	M324 Ceiling Bracket	37-60*	0.03	0.75BMT	G300
M324-4	M324 Ceiling Bracket	52-75*	0.04	0.75BMT	G300
M324-6	M324 Ceiling Bracket	67-90*	0.05	0.75BMT	G300
M324-8	M324 Ceiling Bracket	82-105*	0.06	0.75BMT	G300

* This is the distance between the concrete substrate and the back face of the plasterboard lining. Example: for a 85mm overall ceiling cavity using one layer of 13mm plasterboard, use a M324-4 Ceiling Bracket (85mm - 13mm = 72mm [bracket is adjustable 52~75mm]).



Span Tables - M355 35mm Ceiling Channel

Table 18

SLIMCEIL CEILING LOAD TABLE		
M355 Channel Spacing	450mm	600mm
M324 Bracket Fixing Spacing	Maximum Ceiling Weight – kg per sqm.	
900mm	85 kg/m ²	64 kg/m ²
1200mm	47 kg/m ²	34 kg/m ²

Section Properties and Dimensions

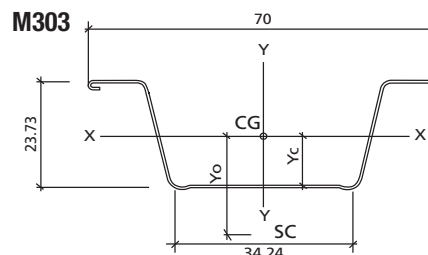
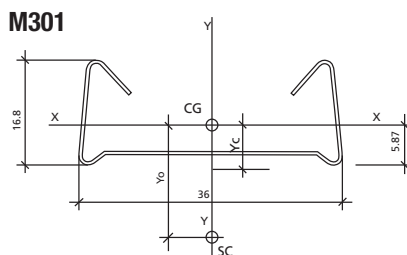
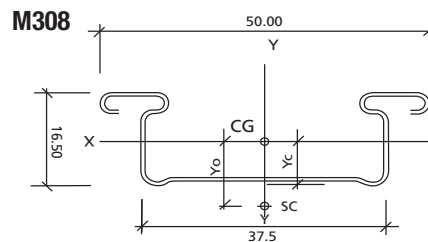
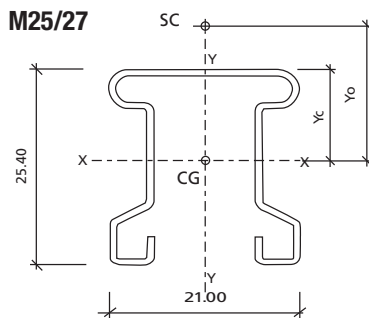
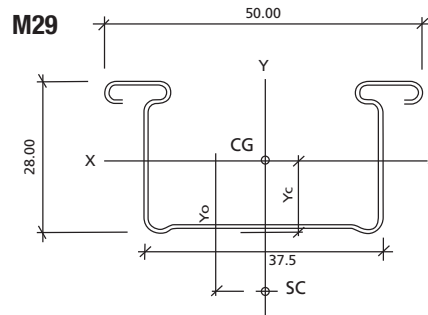
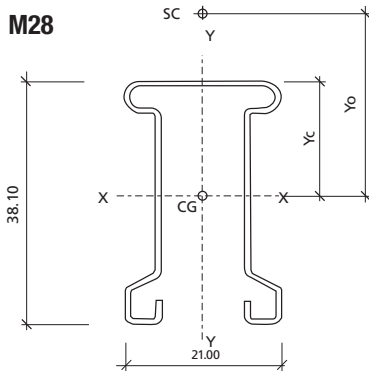
Concealed Ceiling Systems

Table 19

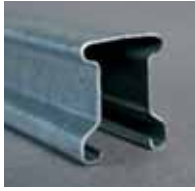
CONCEALED CEILING SECTIONS PROPERTIES AND DIMENSIONS												
Section	BMT mm	Area mm ²	Yc mm	Yo mm	Ixx mm ⁴ x10 ³	Iyy mm ⁴ x10 ³	Zxx mm ³	Zyy mm ³	rx mm	ry mm	Iw mm ⁶ x10 ⁶	J mm ³
M29	0.5	60.73	13.45	24.28	7.19	17.74	494	710	10.88	17.09	1.59	5.06
M308	0.5	49.45	7.28	12.93	2.02	13.89	231	556	6.39	16.76	0.42	4.12
M25	0.55	50.37	11.73	21.61	4.14	2.78	303	265	9.06	7.43	0.24	5.08
M27	0.75	68.69	11.73	21.90	5.64	3.80	413	362	9.06	7.43	0.33	12.88
M28	0.75	87.74	17.95	36.41	15.84	4.48	786	426	13.44	7.14	0.74	16.45
M303	0.42	45.92	11.07	21.93	4.34	19.93	336	585	9.72	20.83	0.59	2.70
M301	0.45	34.20	5.85	15.38	0.96	6.28	94.76	358	5.30	13.55	0.333	2.31

Notes:

1. The above tables show the gross section properties. Designs using these tables need to be checked in accordance with AS/NZS4600.
2. Properties may vary because of manufacturing tolerances, total material used will not vary.
3. All section capacity calculated based on effective section at yield.



Span Tables - M25 Top Cross Rail



**M25
25mm Top Cross Rail
0.55 BMT**

Table 20

MAXIMUM CEILING LOAD-M25 TOP CROSS RAIL SPAN: 900mm				
FURRING CHANNEL	M29		M308	
Furring Channel Spacing	450mm	600mm	450mm	600mm
Top Cross Rail Spacing	Maximum Ceiling Weight – kg per sqm.			
900mm	50.00	49.00	36.00	29.50
1200mm	34.50	33.50	15.50	11.00
1500mm	21.50	15.00	7.00	5.00
1800mm	9.50	6.50	N/A	N/A

Table 21

MAXIMUM CEILING LOAD-M25 TOP CROSS RAIL SPAN: 1200mm				
FURRING CHANNEL	M29		M308	
Furring Channel Spacing	450mm	600mm	450mm	600mm
Top Cross Rail Spacing	Maximum Ceiling Weight – kg per sqm.			
900mm	20.00	19.50	19.50	18.50
1200mm	13.50	13.00	12.50	11.00
1500mm	11.00	10.50	7.00	4.50
1800mm	9.00	6.00	N/A	N/A

Table 22

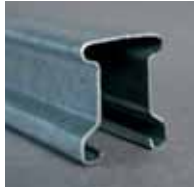
MAXIMUM CEILING LOAD-M25 TOP CROSS RAIL SPAN: 1500mm				
FURRING CHANNEL	M29		M308	
Furring Channel Spacing	450mm	600mm	450mm	600mm
Top Cross Rail Spacing	Maximum Ceiling Weight – kg per sqm.			
900mm	9.50	9.50	9.00	9.00
1200mm	6.00	6.00	5.50	5.50
1500mm	4.00	4.00	4.00	4.00
1800mm	N/A	N/A	N/A	N/A

Notes:

- Span tables are based on the effective section properties as per AS/NZS 4600.
- Tables 20-28 are for Internal applications with a maximum design pressure of 0.25 kPa as per BCA 2009.

Span Tables - M27 Top Cross Rail

Concealed Ceiling Systems



M27
25mm Top Cross Rail
0.75 BMT

Table 23

MAXIMUM CEILING LOAD-M27 TOP CROSS RAIL SPAN: 900mm				
FURRING CHANNEL	M29		M308	
Furring Channel Spacing	450mm	600mm	450mm	600mm
Top Cross Rail Spacing	Maximum Ceiling Weight – kg per sqm.			
900mm	67.00	66.00	41.00	30.50
1200mm	47.00	36.00	15.50	11.00
1500mm	22.00	16.00	6.50	4.50
1800mm	10.00	6.50	N/A	N/A

Table 24

MAXIMUM CEILING LOAD-M27 TOP CROSS RAIL SPAN: 1200mm				
FURRING CHANNEL	M29		M308	
Furring Channel Spacing	450mm	600mm	450mm	600mm
Top Cross Rail Spacing	Maximum Ceiling Weight – kg per sqm.			
900mm	28.00	28.00	26.00	25.50
1200mm	19.50	19.50	14.50	11.50
1500mm	15.50	15.00	6.50	4.50
1800mm	10.00	6.00	N/A	N/A

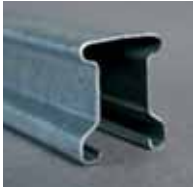
Table 25

MAXIMUM CEILING LOAD-M27 TOP CROSS RAIL SPAN: 1500mm				
FURRING CHANNEL	M29		M308	
Furring Channel Spacing	450mm	600mm	450mm	600mm
Top Cross Rail Spacing	Maximum Ceiling Weight – kg per sqm.			
900mm	13.00	13.00	12.50	12.00
1200mm	9.50	9.00	9.00	9.00
1500mm	6.50	6.50	6.00	5.00
1800mm	5.50	5.50	N/A	N/A

Notes:

- Span tables are based on the effective section properties as per AS/NZS 4600.
- Tables 20-28 are for Internal applications with a maximum design pressure of 0.25 kPa as per BCA 2009.

Span Tables - M28 Top Cross Rail



M28
38mm Top Cross Rail
0.75 BMT

Table 26

MAXIMUM CEILING LOAD-M28 TOP CROSS RAIL SPAN: 1200mm				
FURRING CHANNEL	M29		M308	
Furring Channel Spacing	450mm	600mm	450mm	600mm
Top Cross Rail Spacing	Maximum Ceiling Weight – kg per sqm.			
900mm	55.00	51.00	41.00	31.00
1200mm	39.00	37.50	16.50	12.50
1500mm	23.00	16.50	7.50	5.00
1800mm	11.50	7.00	N/A	N/A

Table 27

MAXIMUM CEILING LOAD-M28 TOP CROSS RAIL SPAN: 1500mm				
FURRING CHANNEL	M29		M308	
Furring Channel Spacing	450mm	600mm	450mm	600mm
Top Cross Rail Spacing	Maximum Ceiling Weight – kg per sqm.			
900mm	25.00	23.00	23.00	22.00
1200mm	18.00	17.00	15.50	12.00
1500mm	15.00	16.00	7.50	5.00
1800mm	10.50	7.00	N/A	N/A

Table 28

MAXIMUM CEILING LOAD-M28 TOP CROSS RAIL SPAN: 1800mm				
FURRING CHANNEL	M29		M308	
Furring Channel Spacing	450mm	600mm	450mm	600mm
Top Cross Rail Spacing	Maximum Ceiling Weight – kg per sqm.			
900mm	15.00	13.00	12.00	11.00
1200mm	10.00	9.00	8.00	7.00
1500mm	8.00	7.00	6.00	5.00
1800mm	5.00	4.00	N/A	N/A

Notes:

1. Span tables are based on the effective section properties as per AS/NZS 4600.
2. Tables 20-28 are for Internal applications with a maximum design pressure of 0.25 kPa as per BCA 2009.

Span Tables - M29 Furring Channel - Direct Fix

Concealed Ceiling Systems



M29
28mm Furring Channel

Table 29

MAXIMUM SPANS - WIND LOADS N1/N2 - M29 28mm FURRING CHANNEL DIRECT FIX				
FURRING CHANNEL SPACING	450mm	600mm	450mm	600mm
PLASTERBOARD LINING	SINGLE SPAN		CONTINUOUS SPAN	
1 layer 10mm	1270mm	1170mm	1730mm	1605mm
1 layer 13mm	1230mm	1140mm	1690mm	1560mm
1 layer 16mm	1200mm	1120mm	1650mm	1525mm
2 layers 10mm	1170mm	1070mm	1605mm	1475mm
2 layers 13mm	1150mm	1060mm	1580mm	1450mm
2 layers 16mm	1100mm	1020mm	1525mm	1400mm

Table 30

MAXIMUM SPANS - WIND LOADS N3/C1 - M29 28mm FURRING CHANNEL DIRECT FIX				
FURRING CHANNEL SPACING	450mm	600mm	450mm	600mm
PLASTERBOARD LINING	SINGLE SPAN		CONTINUOUS SPAN	
1 layer 10mm	1140mm	1060mm	1570mm	1450mm
1 layer 13mm	1115mm	1040mm	1540mm	1420mm
1 layer 16mm	1100mm	1020mm	1515mm	1400mm
2 layers 10mm	1075mm	995mm	1475mm	1365mm
2 layers 13mm	1060mm	980mm	1460mm	1350mm
2 layers 16mm	1030mm	960mm	1415mm	1320mm

Table 31

MAXIMUM SPANS - WIND LOADS N4/C2 - M29 28mm FURRING CHANNEL DIRECT FIX				
FURRING CHANNEL SPACING	450mm	600mm	450mm	600mm
PLASTERBOARD LINING	SINGLE SPAN		CONTINUOUS SPAN	
1 layer 10mm	850mm	775mm	1200mm	1050mm
1 layer 13mm	860mm	785mm	1210mm	1060mm
1 layer 16mm	870mm	790mm	1218mm	1070mm
2 layers 10mm	880mm	805mm	1235mm	1075mm
2 layers 13mm	890mm	810mm	1240mm	1090mm
2 layers 16mm	900mm	815mm	1255mm	1105mm

Table 32

MAXIMUM SPANS - WIND LOADS N5/C3 - M29 28mm FURRING CHANNEL DIRECT FIX				
FURRING CHANNEL SPACING	450mm	600mm	450mm	600mm
PLASTERBOARD LINING	SINGLE SPAN		CONTINUOUS SPAN	
1 layer 10mm	725mm	650mm	925mm	800mm
1 layer 13mm	735mm	660mm	935mm	810mm
1 layer 16mm	745mm	670mm	945mm	820mm
2 layers 10mm	760mm	685mm	960mm	835mm
2 layers 13mm	765mm	690mm	965mm	840mm
2 layers 16mm	778mm	700mm	980mm	870mm

Notes:

1. Span tables are based on the effective section properties as per AS/NZS 4600.
2. Strength and serviceability criteria compliant.
3. Serviceability deflection limit L/300.
4. Tables 29-42 for external/internal applications and relative to wind class as per AS 1170.1, 1170.2 and AS/NZS 4600.
5. Wind classification as per AS 4055.

Span Tables - M308 Furring Channel - Direct Fix



M308
16mm Furring Channel

Table 33

MAXIMUM SPANS - WIND LOADS N1/N2 - M308 16mm FURRING CHANNEL DIRECT FIX				
FURRING CHANNEL SPACING	450mm	600mm	450mm	600mm
PLASTERBOARD LINING	SINGLE SPAN		CONTINUOUS SPAN	
1 layer 10mm	1040mm	950mm	1380mm	1260mm
1 layer 13mm	1010mm	930mm	1350mm	1240mm
1 layer 16mm	960mm	905mm	1320mm	1200mm
2 layers 10mm	910mm	850mm	1150mm	1015mm
2 layers 13mm	900mm	840mm	1160mm	1010mm
2 layers 16mm	850mm	760mm	1100mm	1005mm

Table 34

MAXIMUM SPANS - WIND LOADS N3/C1 - M308 16mm FURRING CHANNEL DIRECT FIX				
FURRING CHANNEL SPACING	450mm	600mm	450mm	600mm
PLASTERBOARD LINING	SINGLE SPAN		CONTINUOUS SPAN	
1 layer 10mm	910mm	830mm	1250mm	1140mm
1 layer 13mm	900mm	820mm	1220mm	1120mm
1 layer 16mm	890mm	800mm	1205mm	1100mm
2 layers 10mm	850mm	760mm	1150mm	1110mm
2 layers 13mm	840mm	750mm	1110mm	1050mm
2 layers 16mm	820mm	740mm	1100mm	1015mm

Table 35

MAXIMUM SPANS - WIND LOADS N4/C2 - M308 16mm FURRING CHANNEL DIRECT FIX				
FURRING CHANNEL SPACING	450mm	600mm	450mm	600mm
PLASTERBOARD LINING	SINGLE SPAN		CONTINUOUS SPAN	
1 layer 10mm	740mm	640mm	990mm	890mm
1 layer 13mm	750mm	650mm	1000mm	900mm
1 layer 16mm	760mm	660mm	1010mm	910mm
2 layers 10mm	770mm	670mm	1020mm	920mm
2 layers 13mm	780mm	680mm	1030mm	930mm
2 layers 16mm	800mm	700mm	1050mm	945mm

Table 36

MAXIMUM SPANS - WIND LOADS N5/C3 - M308 16mm FURRING CHANNEL DIRECT FIX				
FURRING CHANNEL SPACING	450mm	600mm	450mm	600mm
PLASTERBOARD LINING	SINGLE SPAN		CONTINUOUS SPAN	
1 layer 10mm	640mm	590mm	840mm	790mm
1 layer 13mm	650mm	610mm	850mm	800mm
1 layer 16mm	660mm	620mm	860mm	810mm
2 layers 10mm	670mm	630mm	870mm	820mm
2 layers 13mm	680mm	640mm	880mm	830mm
2 layers 16mm	705mm	650mm	900mm	850mm

Notes:

- Span tables are based on the effective section properties as per AS/NZS 4600.
- Strength and serviceability criteria compliant.
- Serviceability deflection limit L/300.
- Tables 29-42 for external/internal applications and relative to wind class as per AS 1170.1, 1170.2 and AS/NZS 4600.
- Wind classification as per AS 4055.

Span Tables - M301 Batten - Direct Fix

Concealed Ceiling Systems



M301
16mm Ceiling Batten

Table 37

MAXIMUM SPANS - WIND LOADS N1/N2 - M301 16mm CEILING BATTEN DIRECT FIX				
BATTEN SPACING	450mm	600mm	450mm	600mm
PLASTERBOARD LINING	SINGLE SPAN		CONTINUOUS SPAN	
1 layer 10mm	970mm	920mm	1200mm	1200mm
1 layer 13mm	970mm	920mm	1200mm	1200mm

Table 38

MAXIMUM SPANS - WIND LOADS N3/C1 - M301 16mm CEILING BATTEN DIRECT FIX				
BATTEN SPACING	450mm	600mm	450mm	600mm
PLASTERBOARD LINING	SINGLE SPAN		CONTINUOUS SPAN	
1 layer 10mm	910mm	820mm	1200mm	1120mm
1 layer 13mm	910mm	820mm	1200mm	1110mm

Notes:

1. Span tables are based on the effective section properties as per AS/NZS 4600.
2. Strength and serviceability criteria compliant.
3. Serviceability deflection limit L/300.
4. Tables 29-42 for external/internal applications and relative to wind class as per AS 1170.1, 1170.2 and AS/NZS 4600.
5. Wind classification as per AS 4055.

WIND CLASSIFICATIONS

- N1/N2 COVERS GENERAL SUBURBAN HOUSING
- N3/C1 COVERS EXPOSED OPEN TERRAIN OR ON TOP OF RIDGES
SUBURBAN AREA IN CYCLONIC AREAS
- N4/C2 VERY EXPOSED OVERLOOKING THE COASTLINE
OPEN TERRAIN IN CYCLONIC AREAS
- N5/C3 MAINLY RELATES TO VERY EXPOSED CYCLONIC CONDITIONS
INCLUDING FAR NORTH QUEENSLAND AND PORT HEDLAND

Span Tables - M303 Batten - Direct Fix



M303
24mm Cyclonic
Ceiling Batten

Table 39

MAXIMUM SPANS - WIND LOADS N1/N2 - M303 24mm CYCLONIC CEILING BATTEN DIRECT FIX				
BATTEN SPACING	450mm	600mm	450mm	600mm
PLASTERBOARD LINING	SINGLE SPAN		CONTINUOUS SPAN	
1 layer 10mm	970mm	890mm	1350mm	1250mm
1 layer 13mm	940mm	870mm	1290mm	1200mm
1 layer 16mm	920mm	850mm	1260mm	1160mm
2 layers 13mm	880mm	810mm	1200mm	1110mm
2 layers 16mm	860mm	780mm	1160mm	1070mm

Table 40

MAXIMUM SPANS - WIND LOADS N3/C1 - M303 24mm CYCLONIC CEILING BATTEN DIRECT FIX				
BATTEN SPACING	450mm	600mm	450mm	600mm
PLASTERBOARD LINING	SINGLE SPAN		CONTINUOUS SPAN	
1 layer 10mm	870mm	810mm	1200mm	1110mm
1 layer 13mm	860mm	800mm	1180mm	1090mm
1 layer 16mm	850mm	780mm	1150mm	1070mm
2 layers 13mm	820mm	750mm	1120mm	1030mm
2 layers 16mm	800mm	740mm	1090mm	1000mm

Table 41

MAXIMUM SPANS - WIND LOADS N4/C2 - M303 24mm CYCLONIC CEILING BATTEN DIRECT FIX				
BATTEN SPACING	450mm	600mm	450mm	600mm
PLASTERBOARD LINING	SINGLE SPAN		CONTINUOUS SPAN	
1 layer 10mm	680mm	620mm	1030mm	800mm
1 layer 13mm	690mm	630mm	1040mm	810mm
1 layer 16mm	700mm	640mm	1050mm	820mm
2 layers 13mm	720mm	660mm	1075mm	840mm
2 layers 16mm	730mm	670mm	1085mm	850mm

Table 42

MAXIMUM SPANS - WIND LOADS N5/C3 - M303 24mm CYCLONIC CEILING BATTEN DIRECT FIX				
BATTEN SPACING	450mm	600mm	450mm	600mm
PLASTERBOARD LINING	SINGLE SPAN		CONTINUOUS SPAN	
1 layer 10mm	600mm	520mm	750mm	630mm
1 layer 13mm	610mm	530mm	760mm	640mm
1 layer 16mm	620mm	540mm	770mm	650mm
2 layers 13mm	640mm	560mm	790mm	670mm
2 layers 16mm	650mm	570mm	800mm	680mm

Notes:

- Span tables are based on the effective section properties as per AS/NZS 4600.
- Strength and serviceability criteria compliant.
- Serviceability deflection limit L/300.
- Tables 29-42 for external/internal applications and relative to wind class as per AS 1170.1, 1170.2 and AS/NZS 4600.
- Wind classification as per AS 4055.



Sound Isolation Systems

Sound Isolations Systems

Resilmounts sound isolation systems cover a wide range of effective solutions for isolating noise transfer for the wall and ceiling industry. There are two types of noise transfer through walls and ceilings, airborne transfer, and structure borne transfer (see Fig 1). Both types need to be considered to achieve the most effective result.

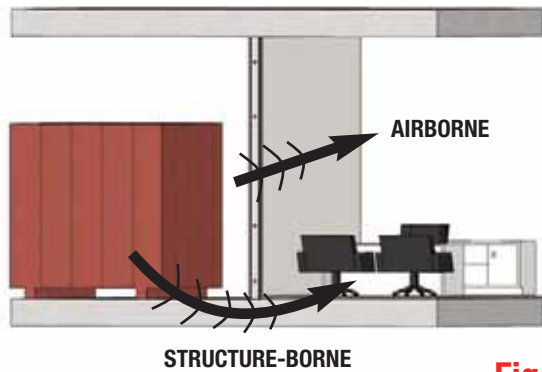


Fig. 1 Noise Transfer

AIRBORNE NOISE

Airborne noise is noise that travels through air, through a direct or open path between the noise source and the recipient. Airborne noise requires sound insulation and isolation control.

STRUCTURE-BORNE NOISE

Structure-borne noise is audible noise which is generated by vibrations induced into the structure. Vibrations can be generated by machinery attached directly to a surface, that in turn transfers into the structure. Another example is the sound of footsteps on the floor above a listener. Structure-borne noise requires the isolation of the vibration itself.

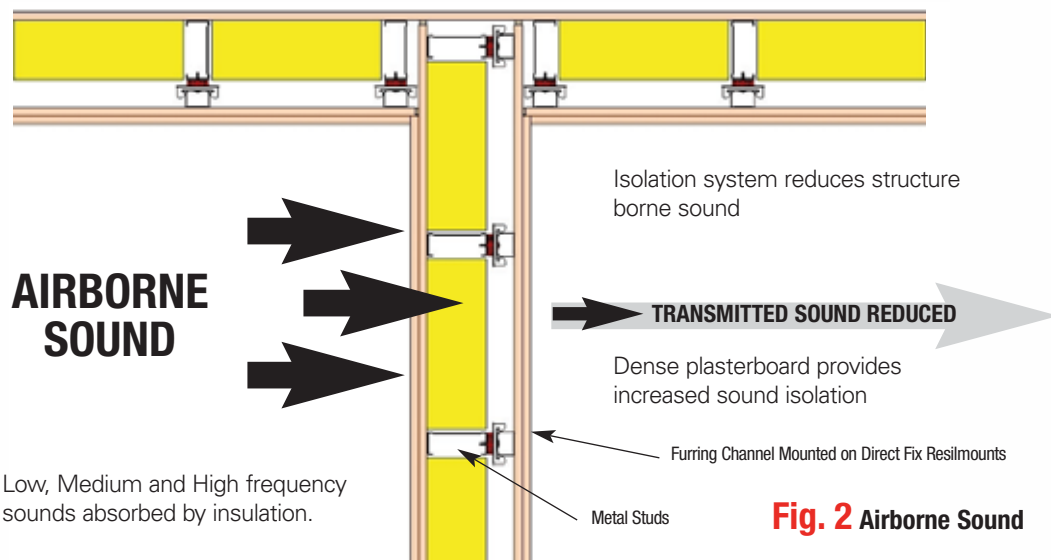


Fig. 2 Airborne Sound

The installation of Resilmounts which suit standard furring channels and top cross rails are one of the most cost effective acoustic control systems as they isolate the system from the structure or adjoining parties. Fig. 2 shows how airborne sound is dissipated by using Resilmount resilient mounts to isolate one face of a wall from another. Resilmounts unique thermoplastic rubber outperforms standard rubber because of its absorbing characteristics. Resilmounts unique sound cell design guards against structure borne vibrations transferring into the body of the Resilmount because of its strong column design providing a small percentage of contact surface area with the structure or substrate it is fixed to.

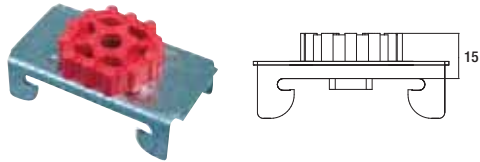
Sound Isolation Systems

Components - Resilient Mounts

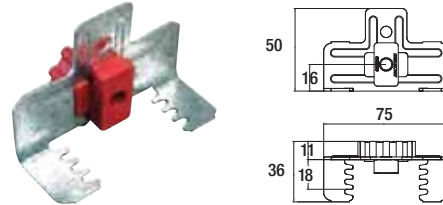


Sound Isolation Systems

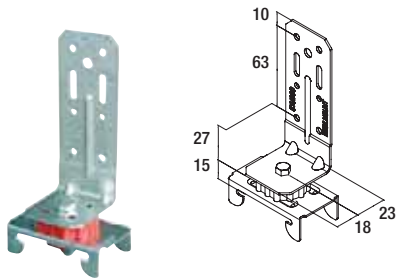
M237R Direct Fix Furring Channel Resilient Mount



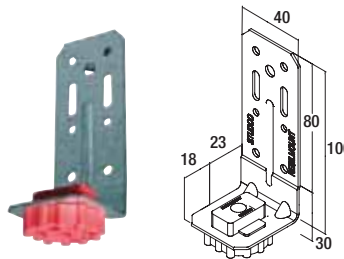
MBFR Adjustable Direct Fix Furring Channel Resilient Mount



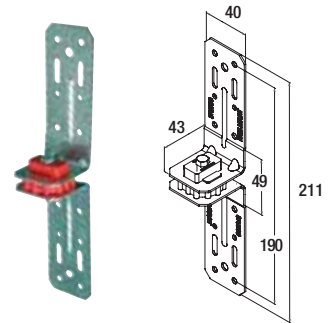
M96R Furring Channel to Purlin Resilient Mount



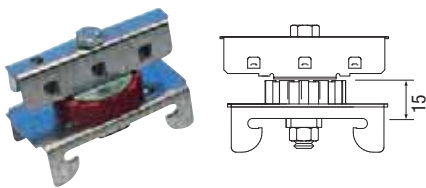
M48R Resilient Mount Right Angle Bracket



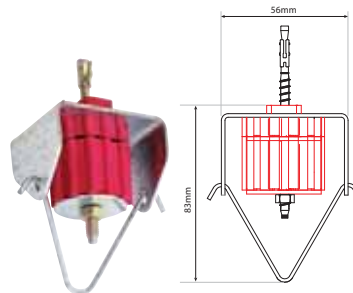
M24R Resilient Joiner Bracket



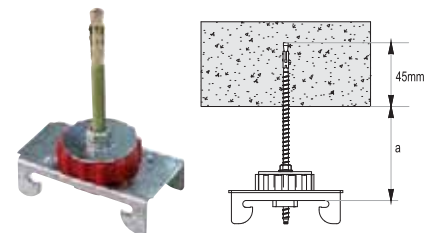
M237TR Furring Channel to Top Cross Rail Resilient Mount



M326R Static Deflection Direct-Fix Resilient Hanger



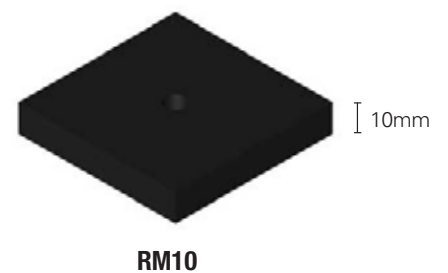
M239R Adjustable Direct-fix Clip



M481R & M482R Isolated Wall Brace



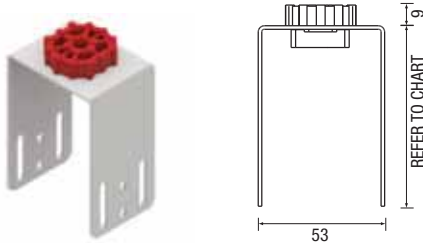
RM10 Rubber Impact Mats



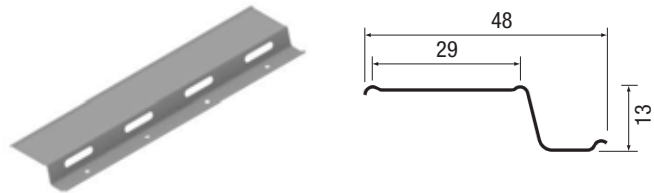
Components - Resilient Mounts



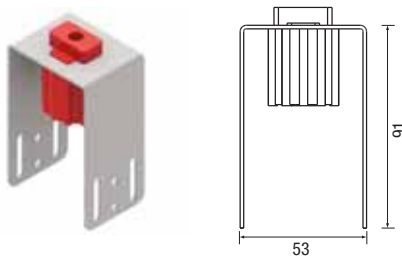
M324R Resilient Mount Ceiling Bracket



M581 Resilmount Resilient Channel



M319R Static Deflection Ceiling Bracket

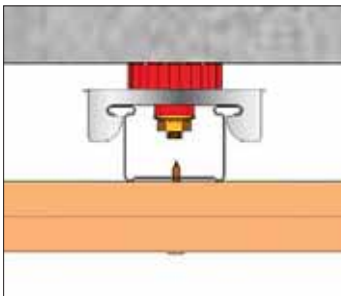


M50R-BLK 54kg Resilient Isolation Hanger
M50R-RED 29kg Resilient Isolation Hanger
M50R-BLU 91kg Resilient Isolation Hanger



Installation Guide - Resilient Mounts

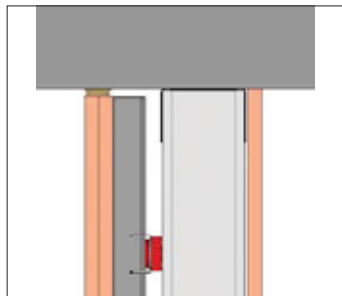
Fig. 1



M237R

Resilient mount shown direct fixed to concrete to provide isolation for wall & ceiling applications

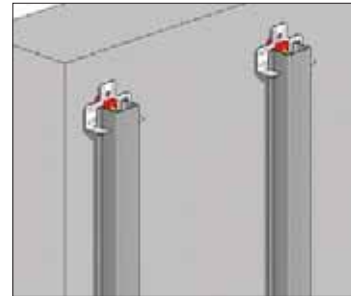
Fig. 2



M237R

Resilient clip shown direct fixed to steel stud to provide greater acoustic ratings.

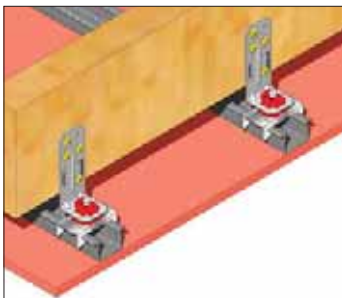
Fig. 3



MBFR

Adjustable resilient mount shown direct fixed to concrete walls. MBFR clips have adjustment of 4 positions at 6mm increments to adjust furring channels, eliminating packers.

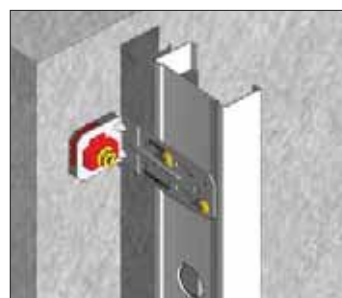
Fig. 4



M96R

Resilient mount shown fixed to purlins or trusses, for the suspension of furring channels. 5mm slotted holes are provided in bracket for adjustability.

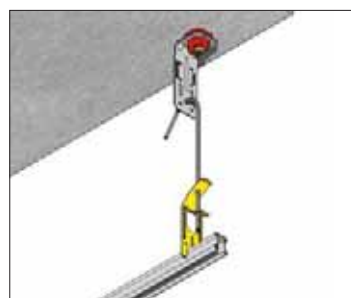
Fig. 5



M48R

Resilient mount shown direct fixed to the structure, to brace an acoustic wall to the structure without compromising sound and vibration transmission requirements.

Fig. 6



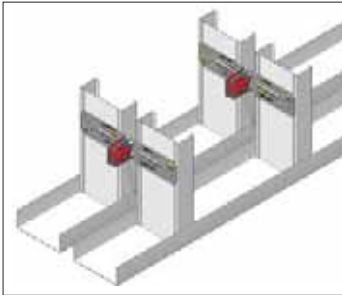
M48R

Resilient mount shown with 5mm suspension rod attached for isolation of ceiling from structure.

Installation Guide - Resilient Mounts

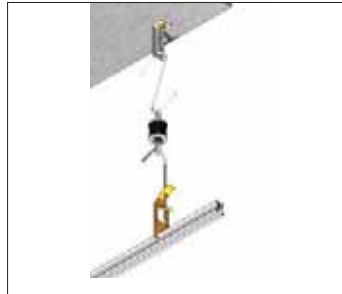


Fig. 7



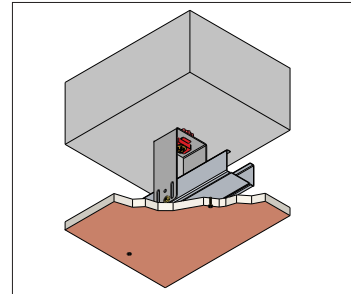
M24R
Resilient mount shown installed in a chase wall to improve the strength and rigidity of the chase walls, allowing both walls to support each other whilst remaining completely isolated.

Fig. 8



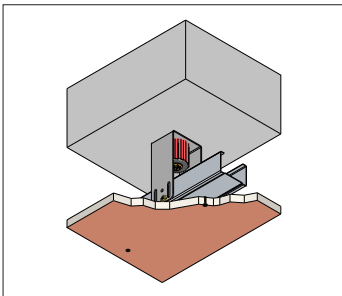
M50R - BLK
Resilient mounts shown with 5mm suspension rod attached for isolation of the ceiling from the structure. The noise absorption properties of this mount allow it to deflect 4.76mm when loaded to the nominated kilogram amount.

Fig. 9



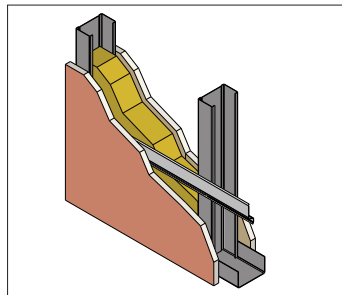
M324R
Resilimount system for low clearance ceiling cavities. Slimceil M324R provides a fully isolated ceiling system, whilst maintaining minimum ceiling cavity.

Fig. 10



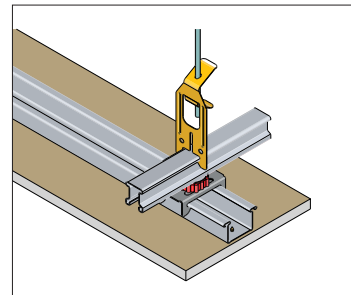
M319R
Resilient mount shown in the Slimceil system. This version of resilient mount meets the requirements of the NCC2011 static deflection requirements.

Fig. 11



M581
Resilient channel fixed to stud wall to provide reduction in sound transmission. Refer to table 43 for Resilient Channel spans.

Fig. 12



M237TR
Resilient mount shown in a concealed ceiling system. M237TR replaces the standard M39 locking key to isolate the ceiling from the support structure.

Span Table - M581



M581
Resilimount Resilient Channel

Table 43

MAXIMUM SPANS - M581 SPAN TABLE		
FURRING CHANNEL SPACING	450mm	600mm
PLASTERBOARD LINING	CONTINUOUS SPAN	
1 LAYER 10MM	600mm	600mm
1 LAYER 13MM	600mm	600mm
1 LAYER 16MM	600mm	600mm
2 LAYERS 10MM	600mm	600mm
2 LAYERS 13MM	600mm	600mm
2 LAYERS 16MM	600mm	600mm

Notes:

1. Span tables are based on the effective section properties as per AS/NZS 4600.
2. Strength and serviceability criteria compliant.
3. Serviceability deflection limit L/360.

Installation Guide - Resilient Mounts



Fig. 1
Resilient Mounts Direct Fixed to Steel Stud Wall Application.

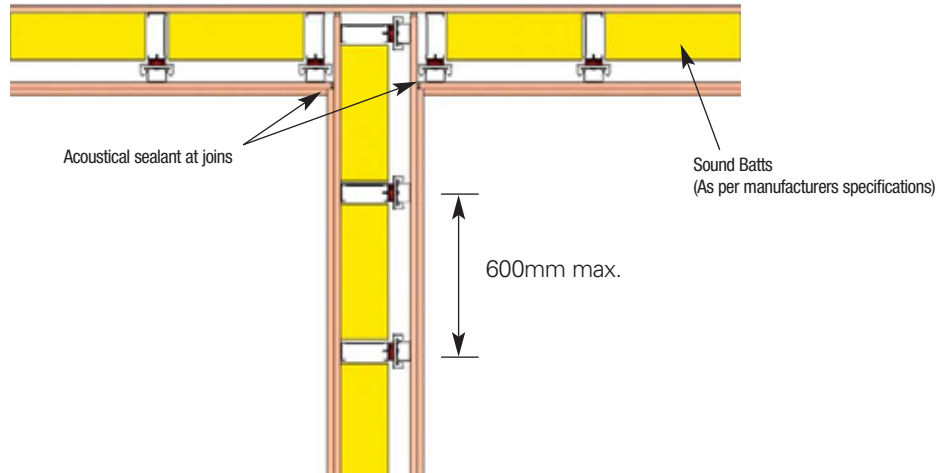
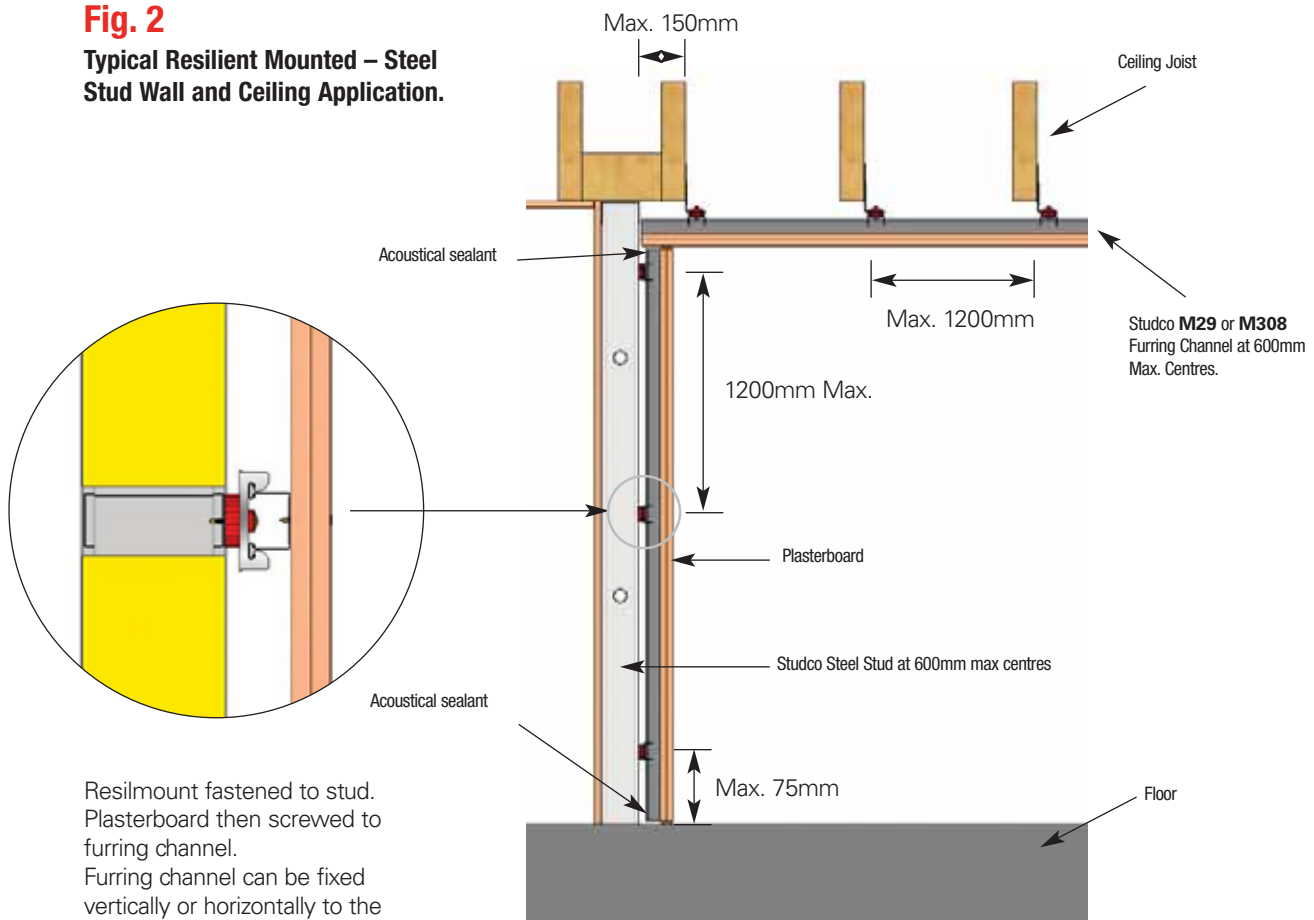
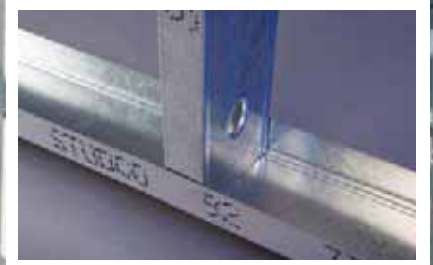


Fig. 2
Typical Resilient Mounted – Steel Stud Wall and Ceiling Application.



Resilimount fastened to stud. Plasterboard then screwed to furring channel. Furring channel can be fixed vertically or horizontally to the structure.

Steel Stud Systems



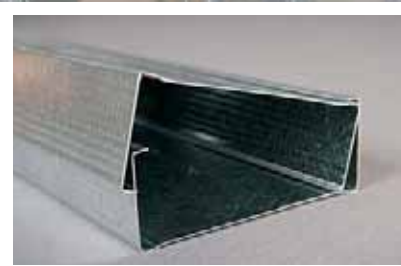
Studco Stud
Fits positively into track



External Infill Framing
Between concrete and steel structures



Service Holes
Bell-mouthed service holes at 500mm centres – do not require grommets for cabling. Knurled face for screw point location.



Boxed Studs
Studco .50, .55 and .75BMT steel studs can be easily boxed together providing extra strength at door openings or where greater loads are required.

Steel Stud Systems

The Studco steel stud framing system is engineered to provide designers and installers the solution to create framing systems that are not only durable and versatile but can also achieve the needs and design criteria in accordance with the BCA and appropriate Australian standards. The Studco steel stud framing system is manufactured in a range of various widths, lengths and material gauges from 0.50mmBMT to 1.5mm BMT. This range of stud and track profiles not only offer greater span and performance, but also are accompanied by a range of accessories including noggings, nogging track and bracket joining systems. The design tables in this section have been formulated to comply with the relevant Australian standards, accompanied by substantial laboratory and field testing. Construction of fire-rated or sound rated wall systems can be achieved by using the Studco steel framing system and accessories. Refer to the building board manufacturers for more detailed information.

Components

Stud and Track Sections

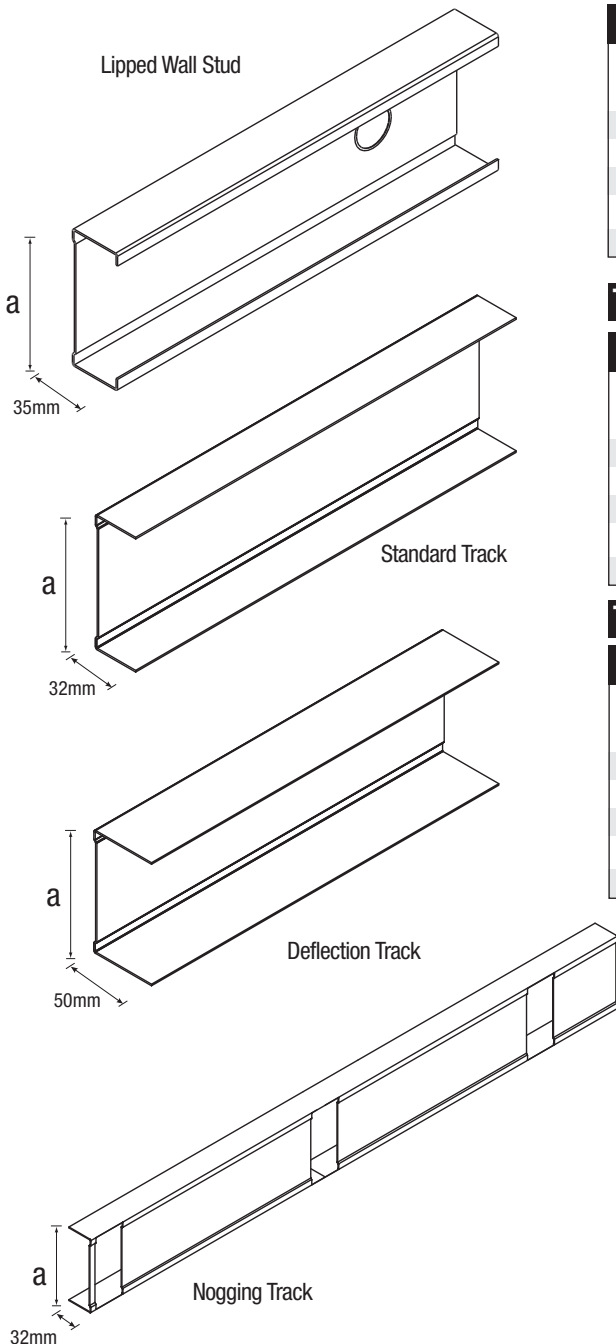


Table 44

LIPPED WALL STUDS - PART NUMBERS				
Section Width "a"	Base Metal Thickness - BMT			
	0.5mm	0.55mm	0.75mm	1.15mm
51mm	S5150	N/A	S5175	N/A
64mm	S6450	N/A	S6475	S64115
76mm	N/A	S7655	S7675	S76115
92mm	N/A	S9255	S9275	S92115
150mm	N/A	N/A	S1507	S15012

Table 45

STANDARD TRACK - PART NUMBERS						
Section Width "a"	Base Metal Thickness - BMT					
	0.5mm	0.5mm Hemmed	0.55mm	0.7 Hemmed	0.75mm	1.15mm
51mm	T5155	N/A	N/A	N/A	T5175	N/A
64mm	T6455	T6455H	N/A	T6475H	T6475	T64115
76mm	T7655	T7655H	N/A	T7675H	T7675	T76115
92mm	T9255	T9255H	N/A	T9275H	T9275	T92115
150mm	N/A	N/A	N/A	N/A	T1507	T15012

Table 46

DEFLECTION HEAD TRACK - PART NUMBERS					
Section Width "a"	Base Metal Thickness - BMT				
	0.5mm	0.55mm	0.7mm hemmed	0.75mm	1.15mm
51mm	N/A	N/A	N/A	DT5175	N/A
64mm	N/A	DT645	DT6475H	DT6475	DT64115
76mm	N/A	DT765	DT7675H	DT7675	DT76115
92mm	N/A	DT925	DT9275H	DT9275	DT92115
150mm	N/A	N/A	N/A	DT1507	DT15012

Table 47

NOGGING TRACK - PART NUMBERS					
Section Width "a"	Nogging Track Centres	Base Metal Thickness - BMT			
		0.5mm	0.55mm	0.75mm	1.15mm
64mm	300mm	N/A	N/A	NT6475-30	N/A
64mm	450mm	N/A	N/A	NT6475-45	N/A
64mm	600mm	N/A	N/A	NT6475-60	N/A
76mm	300mm	N/A	N/A	NT7675-30	N/A
76mm	450mm	N/A	N/A	NT7675-45	N/A
76mm	600mm	N/A	N/A	NT7675-60	N/A
92mm	300mm	N/A	N/A	NT9275-30	N/A
92mm	450mm	N/A	N/A	NT9275-45	N/A
92mm	600mm	N/A	N/A	NT9275-60	N/A
150mm	300mm	N/A	N/A	NT1507-30	N/A
150mm	450mm	N/A	N/A	NT1507-45	N/A
150mm	600mm	N/A	N/A	NT1507-60	N/A

Steel Stud Systems – Components

Noggings

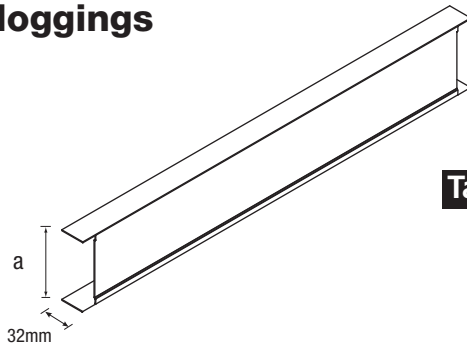


Table 48

NOGGINGS - PART NUMBERS					
Section Width "a"	Noggling Track Centres	Base Metal Thickness - BMT			
		0.5mm	0.55mm	0.75mm	1.15mm
64mm	450mm	N/A	N/A	N6475-45	N/A
64mm	600mm	N/A	N/A	N6475-60	N/A
76mm	450mm	N/A	N/A	N7675-45	N/A
76mm	600mm	N/A	N/A	N7675-60	N/A
92mm	450mm	N/A	N/A	N9275-45	N/A
92mm	600mm	N/A	N/A	N9275-60	N/A
150mm	450mm	N/A	N/A	N1507-45	N/A
150mm	600mm	N/A	N/A	N1507-60	N/A

Noggling Brackets

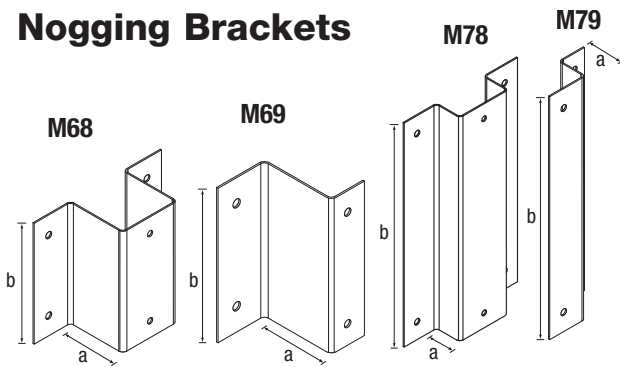


Table 49

NOGGING BRACKETS - PART NUMBERS				
Part No	Section Height "a"	Section length "b"	BMT	Timber Noggling Thickness
M68	36mm	72mm	0.75	35mm
M69	36mm	72mm	0.75	35mm
M78	18mm	150mm	0.75	18mm
M79	18mm	150mm	0.75	18mm

Studco Ezy-Track

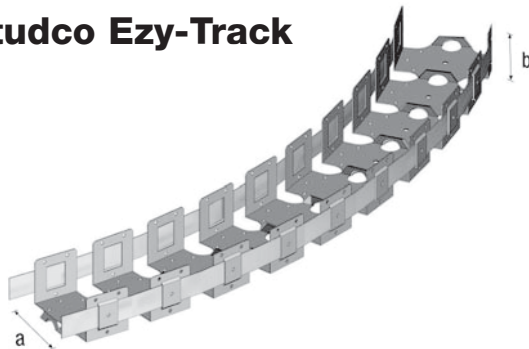


Table 50

EZY TRACK - PART NUMBERS					
Section Width "a"	Track leg height "b"	Base Metal Thickness - BMT			
		0.5mm	0.55mm	0.75mm	1.15mm
51mm	42mm	N/A	N/A	FX51	N/A
64mm	45mm	N/A	N/A	FX64	N/A
76mm	39mm	N/A	N/A	FX76	N/A
92mm	41mm	N/A	N/A	FX92	N/A
150mm	42mm	N/A	N/A	FX150	N/A

Brackets

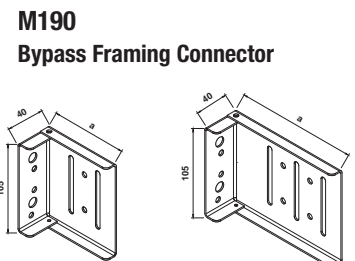
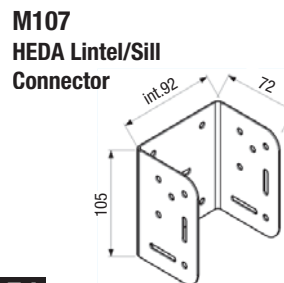
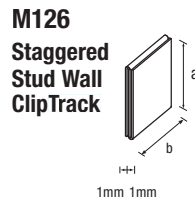
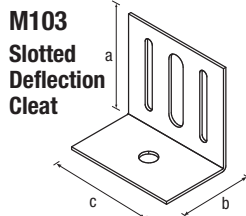
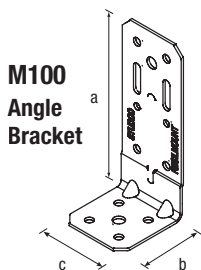
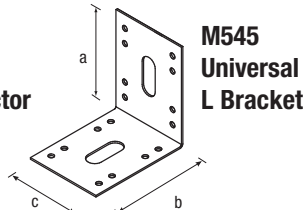
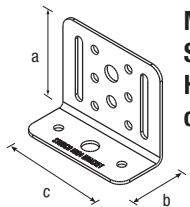


Table 51

BRACKETS - PART NUMBERS				
Part No.	Section Width "a"	Section Width "b"	Section Width "c"	BMT
M100	100mm	45mm	40mm	1.5mm
M103*	75mm	50mm	80mm	3.0mm
M104	65mm	35mm	80mm	2.0mm
M545	75mm	75mm	55mm	1.5mm



* To be superseded by M104

Steel Stud Systems - Wall Studs

HEDAjamb



HEDAjamb 63
(92mm wide)

HEDAjamb 90
(92mm wide)

HEDAjamb 63
(150mm wide)

Table 52

STUDCO HEDA JAMB - PART NUMBERS		
Section Width "a"	Base Metal Thickness - BMT	
	1.15mm	1.55mm
76mm	HJ9276115	N/A
89mm	N/A	HJ9289155

Rapidtrack Slotted Deflection Track

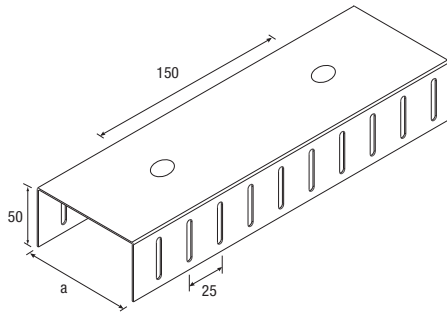


Table 53

RAPIDTRACK				
SECTION WIDTH "a"	Base Metal Thickness - BMT			
	0.5mm	0.55mm	0.75mm	1.15mm
51mm	N/A	N/A	N/A	N/A
64mm	N/A	N/A	DS6475	DS76115
76mm	N/A	N/A	DS7675	N/A
92mm	N/A	N/A	DS9275	DS92115
150mm	N/A	N/A	N/A	DS150115

Hole size is $\phi 14$ mm, suitable for M12 bolts or M10 masonry sleeve anchors.

Strongarm Wall Brace

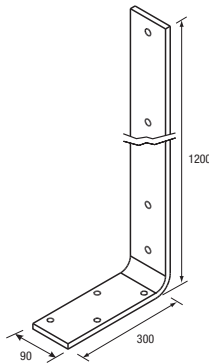


Table 54

PART No	STRONGARM	Section A Height	Section B Length	BMT
M110	StrongArm Wall Brace 1200mm	1200	300	12.0

Slimwall Brackets & Channel

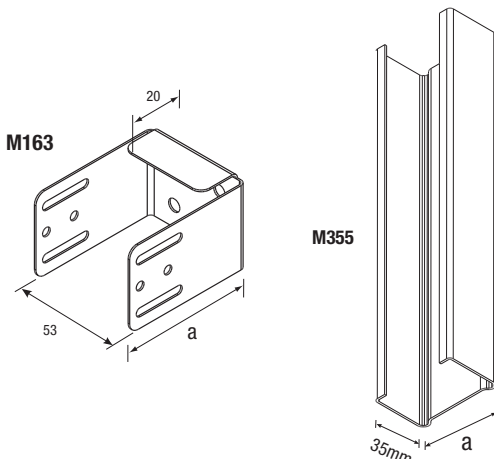


Table 55

PART No	SLIMWALL	Section A Height
M163-6	Slimwall Bracket 69-92mm Cavity	68mm
M163-8	Slimwall Bracket 85-108mm Cavity	84mm
M355	M355 Ceiling Channel	51mm

Steel Stud Systems - Studs

Steel Stud Systems

The Studco lipped wall studs are manufactured in various widths and gauges from 0.50BMT to 1.15BMT. Bell mouth service holes are punched at 500mm centres eliminating the need for cabling grommets. The knurled face along the stud flange provides a positive screw point location. Studs can be boxed or spliced to extend the overall length or to provide strengthening if required. Refer to *Table 47* for splice fixing details.

Table 56

SPLICE STUD FIXING DETAIL			
Wall Height	Splice Position In Wall	No. of Fasteners for both sides of studs at splice joint	
		0.50 / 0.55 / 0.75BMT	1.15BMT
0-6000mm	0 -10%	2	3
	10% - 25%	3	5

Spliced Studs

0.75 BMT - 150mm studs
1.15 BMT - 64, 76, 92, 150mm studs

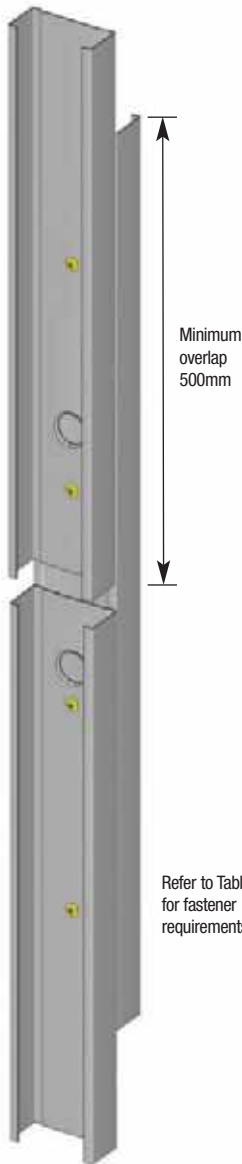


Fig. 1

Spliced Studs – Back to Back
Screw through at maximum 500mm centres.

Spliced Studs

0.50 BMT - 51, 64mm studs
0.55 BMT - 76, 92mm studs
0.75 BMT - 51, 64, 76, 92mm studs



Fig. 2

Spliced Studs - Boxed
Refer to Table 47 for fixing requirements

Boxed Studs

0.50 & 0.55 BMT - all stud sizes



Fig. 3

Boxed Studs - Screw Fixing
only required if studs are unlined.

Back to Back Studs

0.75 & 1.15BMT - all stud sizes

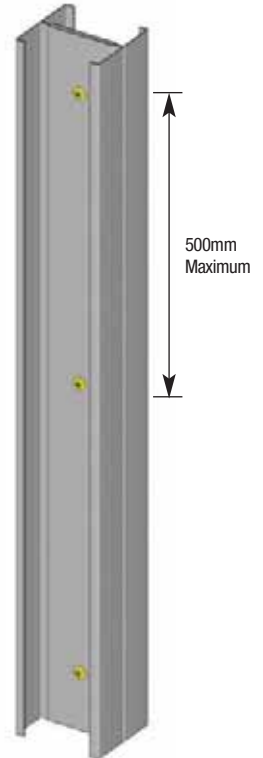


Fig. 4

Back to Back – Fixing for 1.15 stud range in lieu of Boxing stud.
Refer to Table 56 for fixing requirements

Steel Stud Systems - Tracks

The Studco Track sections provide a friction fit for the lipped wall studs. The friction fit holds the studs in position until the lining boards are fixed; this friction fit also accommodates a slip joint to allow for any movement in the primary structure. To allow for this movement to occur it is not recommended that the lining board is fixed to the track sections unless specifically stated. Studco Track Sections are manufactured in two different profiles: a standard track with a nominal leg height of 32mm and the deflection head track with a nominal leg height of 50mm. The standard track is also available with a rolled hemmed edge. This safety hem along the entire length of the track section reduces the exposure to sharp edges whilst also enhancing the rigidity of the profile.

Fig. 1 Bottom Track Fixing

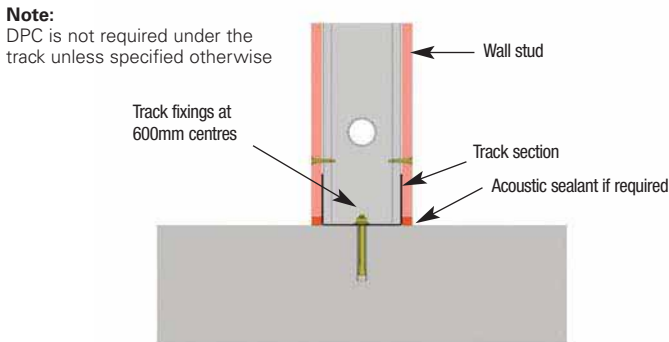
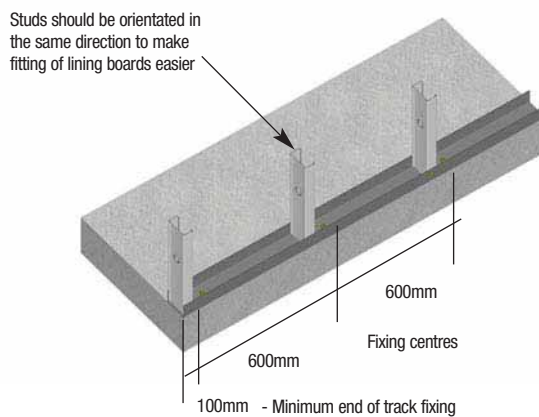


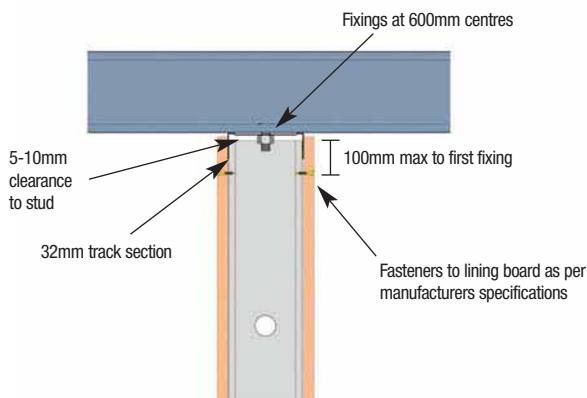
Fig. 2 Fixing Centres



Note:
Use 2 fixings at 600mm centres for the 150mm track section, approximately 20mm in from either side of the track.

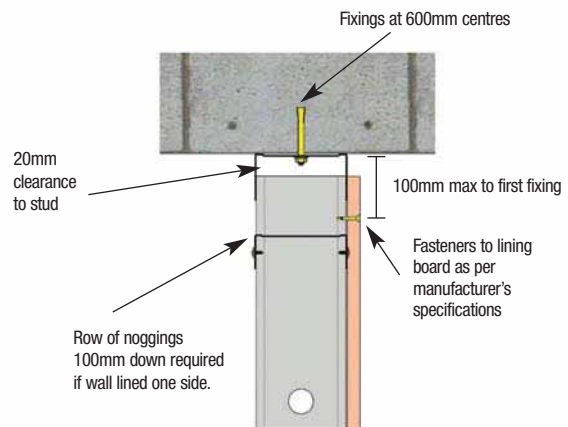
Note:
Where tracks are fastened to concrete minimum edge distances for all fixings must be maintained.

Fig. 3 Friction Fit



Note:
Do not fix cornice to walls rigidly where friction joints are installed.

Fig. 4 Deflection Head



Note:
Do not rigidly fix cornice to walls where deflection head is used.

Steel Stud Systems - Noggings

Studco noggings and nogging tracks are manufactured in a range of sizes to suit standard wall stud centres. Nogging track to suit custom centres and back to back studs is available. The use of noggings is to provide support and also to prevent twisting of the studs during the installation of the lining boards. Noggings also provide extra support to the wall construction, and in some instances a more cost effective design can be achieved by using noggings. Studco manufactures two types of noggings, individual noggings or nogging track. Noggings are supplied as pre-cut individual nogging pieces to save cutting on site and can also be installed after the studs and tracks have been fitted. Nogging track is a continuous track that can be installed in stud framing in one length and requires only two screw fixings per stud connection. Timber noggings may be used, providing they are fixed as per diagram Fig. 3. Treated timber must not be used. The minimum number of noggings for different wall configurations can be established from Table 49. This is applicable for internal walls subjected to 0.25kPa. Walls connected to the underside of a concrete slab must be installed with deflection head track and an additional row of noggings 100mm down, if lined one side only.

Fig. 1 Nogging

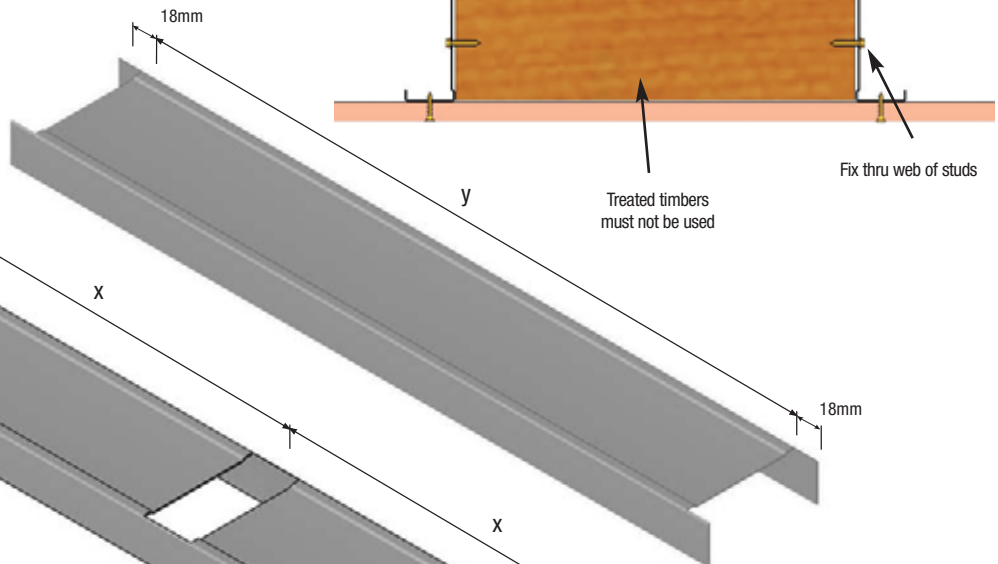


Fig. 3 Timber Nogging

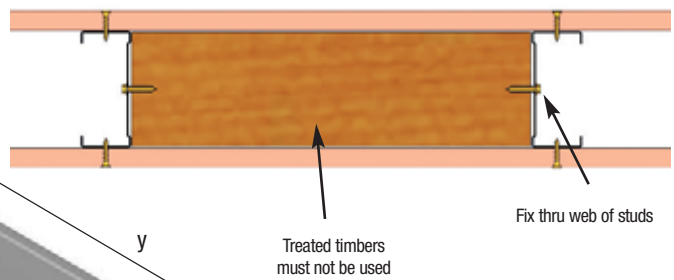


Fig. 2 Nogging Track

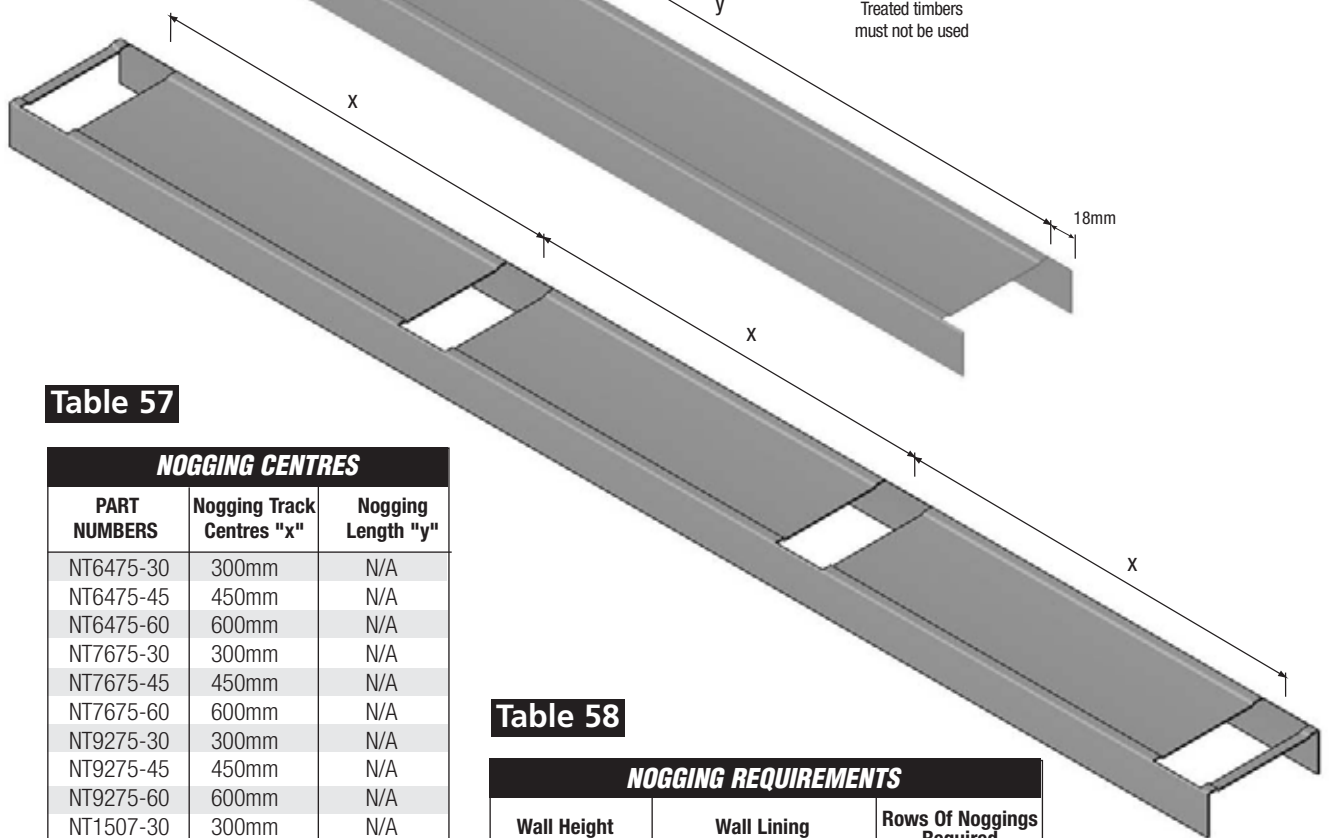


Table 57

NOGGING CENTRES		
PART NUMBERS	Nogging Track Centres "x"	Nogging Length "y"
NT6475-30	300mm	N/A
NT6475-45	450mm	N/A
NT6475-60	600mm	N/A
NT7675-30	300mm	N/A
NT7675-45	450mm	N/A
NT7675-60	600mm	N/A
NT9275-30	300mm	N/A
NT9275-45	450mm	N/A
NT9275-60	600mm	N/A
NT1507-30	300mm	N/A
NT1507-45	450mm	N/A
NT1507-60	600mm	N/A
N6475-45	N/A	412mm
N6475-60	N/A	562mm
N7675-45	N/A	412mm
N7675-60	N/A	562mm
N9275-45	N/A	412mm
N9275-60	N/A	562mm
N1507-45	N/A	412mm
N1507-60	N/A	562mm

Table 58

NOGGING REQUIREMENTS		
Wall Height	Wall Lining	Rows Of Noggings Required
0 - 4.2m	Wall Lined Both Sides	0
4.2m - 8.4m		1
0 - 3.0m	Wall Lined One Side	1
3.0m - 6.0m		2
6.0m - 8.0m		3

Note: Walls connected to the underside of a concrete slab must be installed with deflection head track and additional row of noggings 100mm down if unlined or lined one side only. If slotted deflection head track is used, additional row of noggings 100mm down not required.

Installation Guide - Wall to Ceiling Intersections

Fig. 1 Top Track to Bridging Support Detail

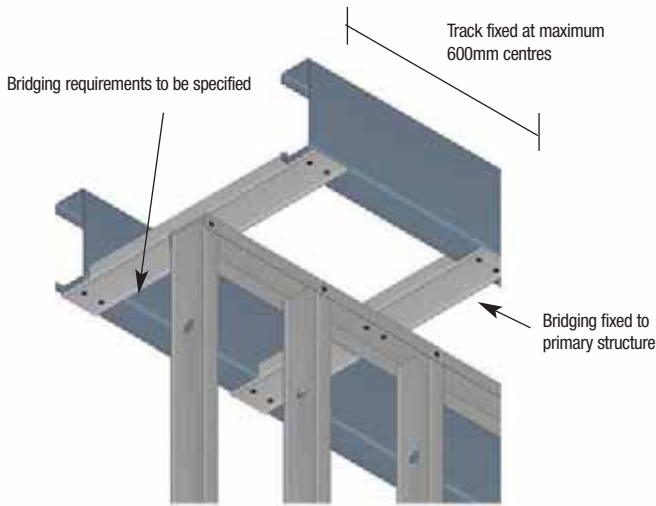


Fig. 2 Concealed Ceiling with Wall Parallel to Furring Channel Detail

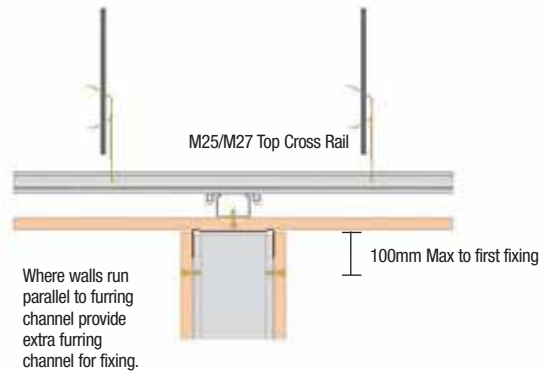


Fig. 3 Concealed Ceiling with Wall Right Angles Connection Detail

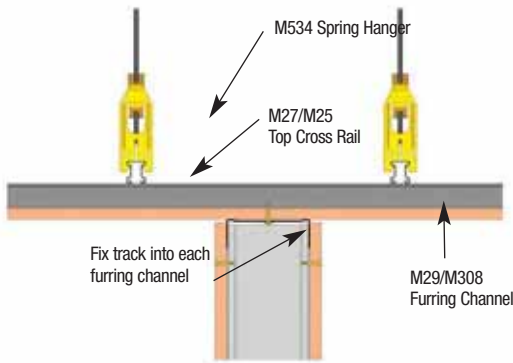


Fig. 4 Exposed T-Bar Ceiling Connection Detail

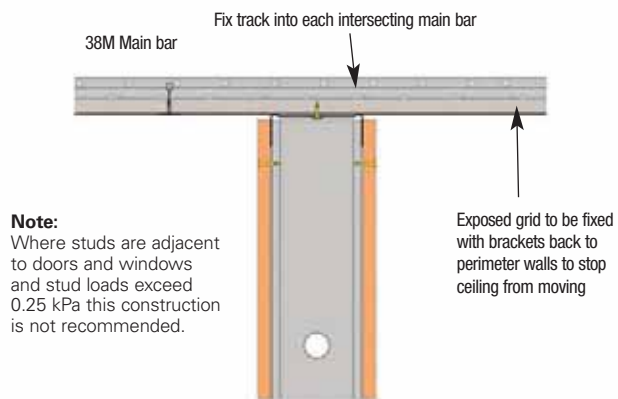


Fig. 5 Decorative Stopping Section with Wall Track Detail

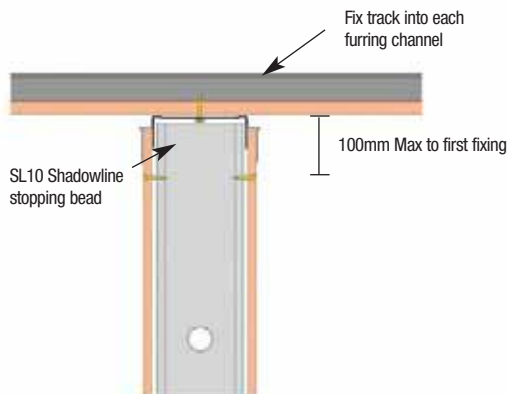
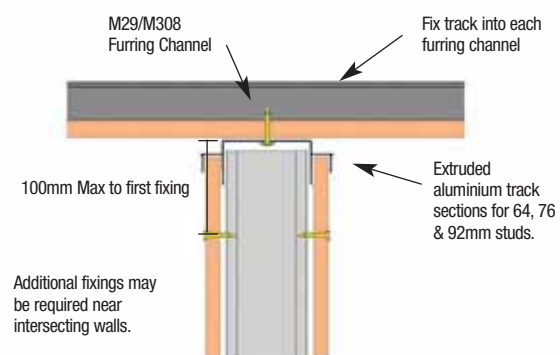


Fig. 6 Decorative Stopping Header Track Detail

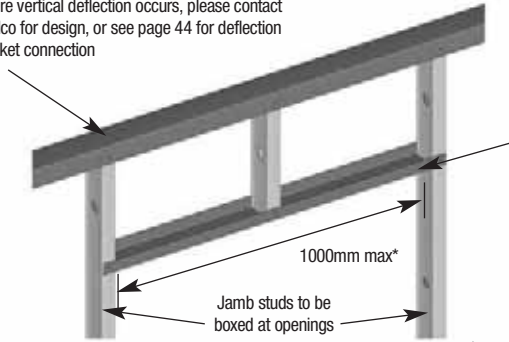


Installation Guide - Internal Stud Walls

Steel Stud Systems

Fig. 1 Door Opening

Jamb studs fixed to top track if no vertical deflection. Where vertical deflection occurs, please contact Studco for design, or see page 44 for deflection bracket connection

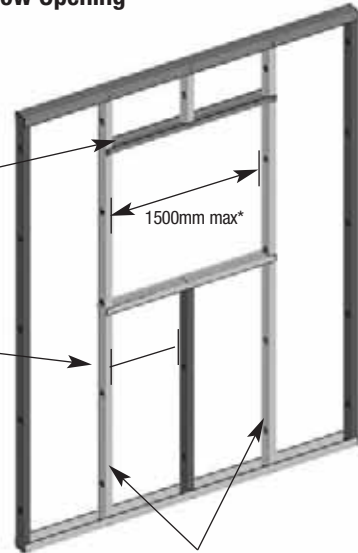


* Door openings over 1000mm and external openings must be checked prior to commencement of work.

Fig. 2 Window Opening

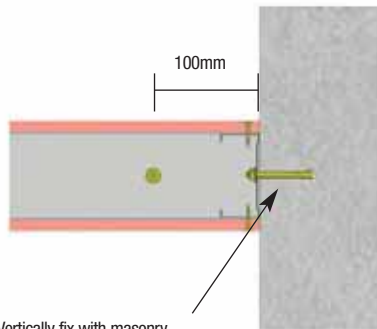
Door/Window header from track section fixed to jamb studs

Stud centres should match the standard wall stud spacing



* Jamb studs to be boxed at openings, window openings over 1500mm and external openings must be checked prior to commencement of work.

Fig. 3 Wall End Intersection to Concrete

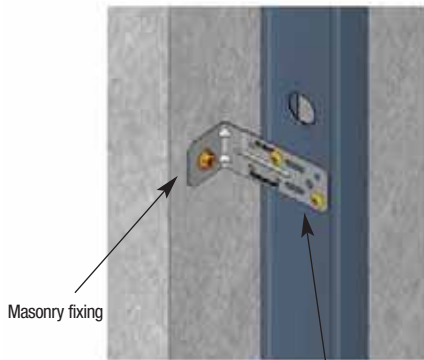


Vertically fix with masonry fixings max 500mm centres

**INTERNAL WALLS ONLY
DESIGN NOT SUITABLE
FOR EXTERIOR WALLS**

Fig. 4 Angle Bracket Connection

* Resilient mount can also be used - see page 29.



Minimum 2 tek screws per connection

* Bracket locations should be checked prior to commencement of work

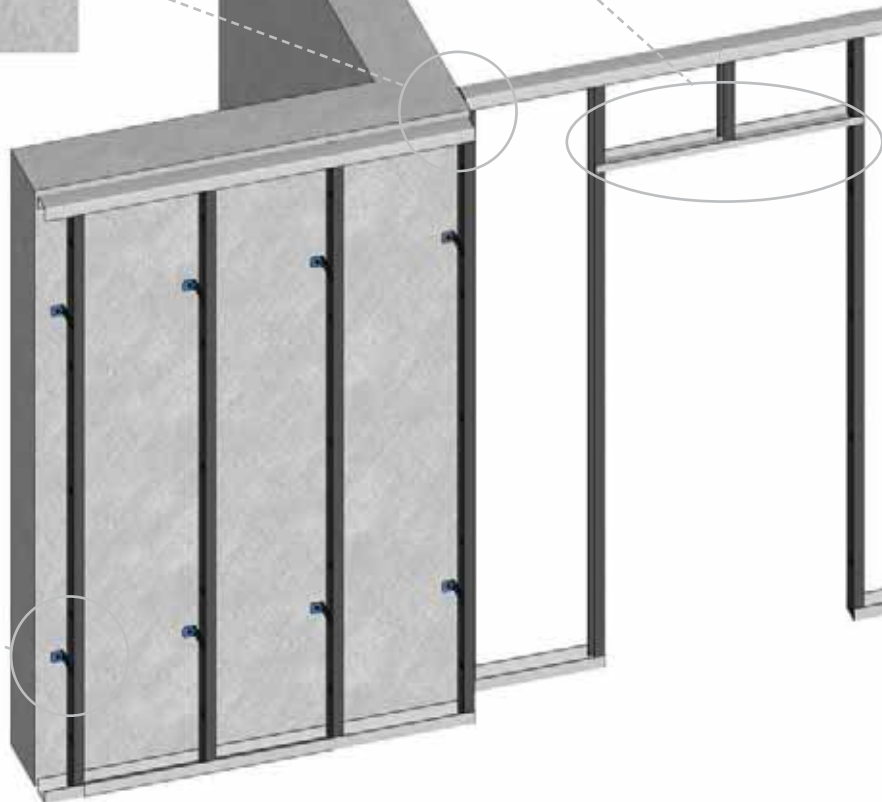


Fig. 5 Wall End

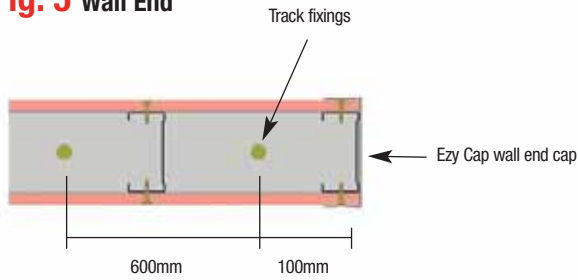


Fig. 6 Corner

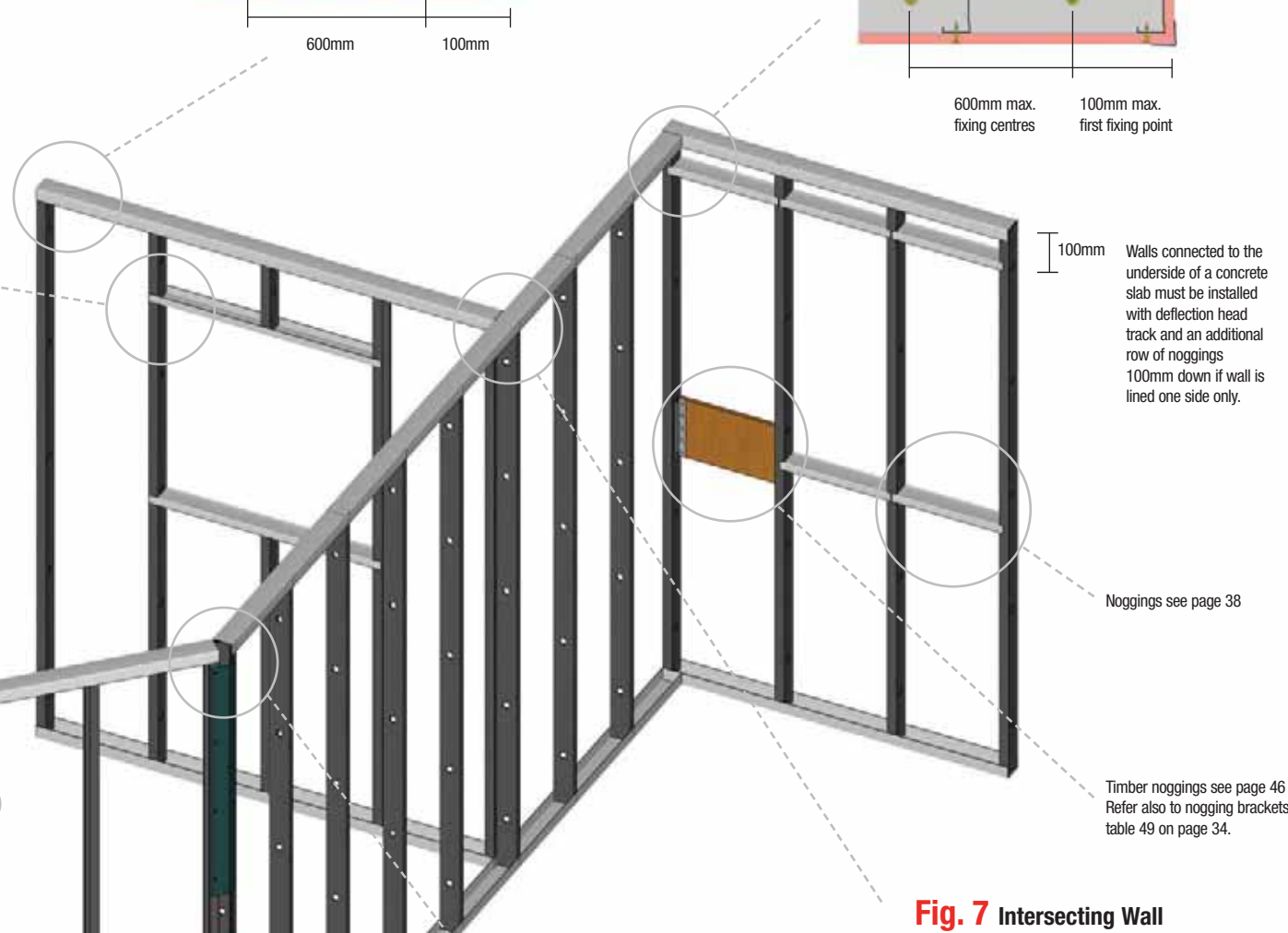
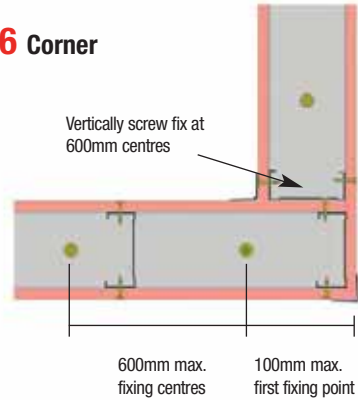


Fig. 8 Angled Wall

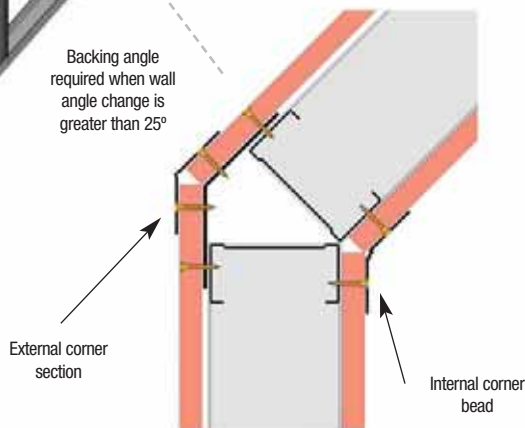
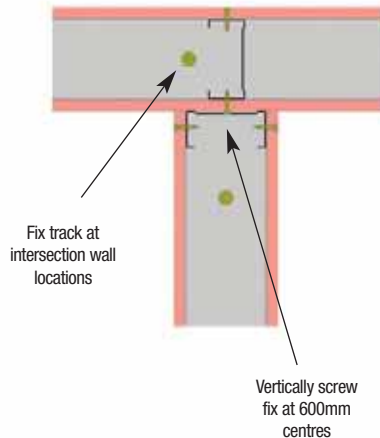


Fig. 7 Intersecting Wall



Installation Guide - Staggered Stud Walls

Staggered Stud Systems provide resistance to sound transmission and acoustic impact. Studs are held in place by using the M126 Staggered Stud Clip or M40 Wall Track as shown in Fig. 1. Refer to Table 59 for maximum wall heights.

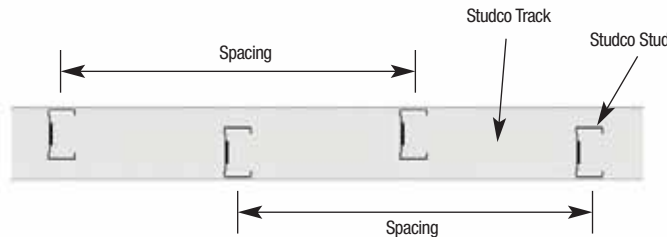


Fig. 1 Typical Staggered Stud Wall Application

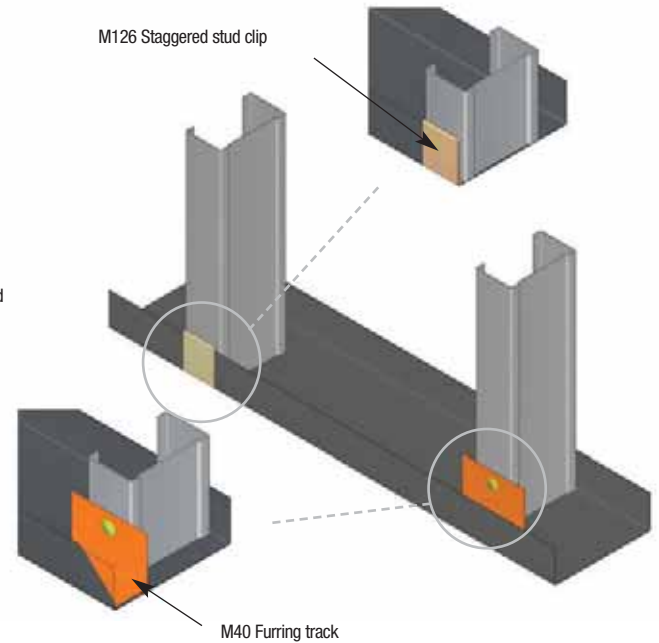


Table 59

MAXIMUM STAGGERED STUD WALL HEIGHTS - SPAN/240										
PLASTER THICKNESS (mm)		10mm PLASTERBOARD			13mm PLASTERBOARD			16mm PLASTERBOARD		
STUD SPACING (MM)		300mm	450mm	600mm	300mm	450mm	600mm	300mm	450mm	600mm
PART NO.	STUD SIZE	MAX WALL HEIGHT (mm)								
S51050	51mm x 0.50BMT	2880	2510	2350	2910	2540	2340	2900	2540	2340
S64050	64mm x 0.50BMT	2930	2600	2390	3000	2660	2380	3080	2710	2380
S64075	64mm x 0.75BMT	3620	3190	2850	3720	3290	2850	3800	3370	2850
S64115	64mm x 1.15BMT	4440	3880	3530	4490	3950	3520	4520	3980	3520
S76055	76mm x 0.55BMT	3170	2810	2610	3240	2850	2620	3290	2930	2610
S76075	76mm x 0.75BMT	3750	3330	3020	3830	3390	3020	3910	3470	3020
S76115	76mm x 1.15BMT	4550	4020	3620	4670	4080	3610	4770	4180	3620
S92055	92mm x 0.55BMT	3380	2980	2750	3440	3030	2740	3500	3050	2730
S92075	92mm x 0.75BMT	3920	3490	3180	3990	3540	3210	4050	3590	3200
S92115	92mm x 1.15BMT	4660	4110	3760	4780	4180	3760	4860	4250	3760
S15007	150mm x 0.75BMT	4440	3990	3690	4480	4010	3670	4520	4050	3670
S15012	150mm x 1.15BMT	5140	4560	4160	5180	4620	4160	5230	4650	4150

Notes:

1. Tabulated heights can not be used for axial loads but include self weight and lateral pressures.
2. Shelf loadings are not included in the tabulated heights.
3. This table is for internal applications only.

Installation Guide - Curved Walls

Curved Walls can be easily constructed by using Studco Ezytrack. Ezytrack can be curved to suit the desired radius and screwed through the side strap to lock the radius into position. Studs are then placed into the Ezytrack and screwed both sides. The Ezytrack is fixed to the primary structure at each Stud location, top and bottom. The use of Ezytrack in bulkhead construction is a cost effective alternative as the Ezytrack can be preformed to your radius then screw locked and installed. For a guide on Stud centres for curved walls, refer to *Table 60* below.

Table 60

PLASTERBOARD THICKNESS	STUDS CENTRES - CURVED WALLS						
	WALL RADIUS						
	800mm-1000mm	1000mm-1500mm	1500mm-2000mm	2000mm-2500mm	2500mm-3000mm	3000mm-4000mm	over 4000mm
	MAXIMUM WALL STUD CENTRES						
6.5mm	150mm	200mm	250mm	300mm	350mm	450mm	550mm
10mm	150mm	200mm	250mm	300mm	350mm	450mm	550mm
13mm	--	150mm	200mm	250mm	300mm	400mm	500mm
16mm	--	--	--	150mm	200mm	250mm	350mm

Fig. 1 Curved Wall

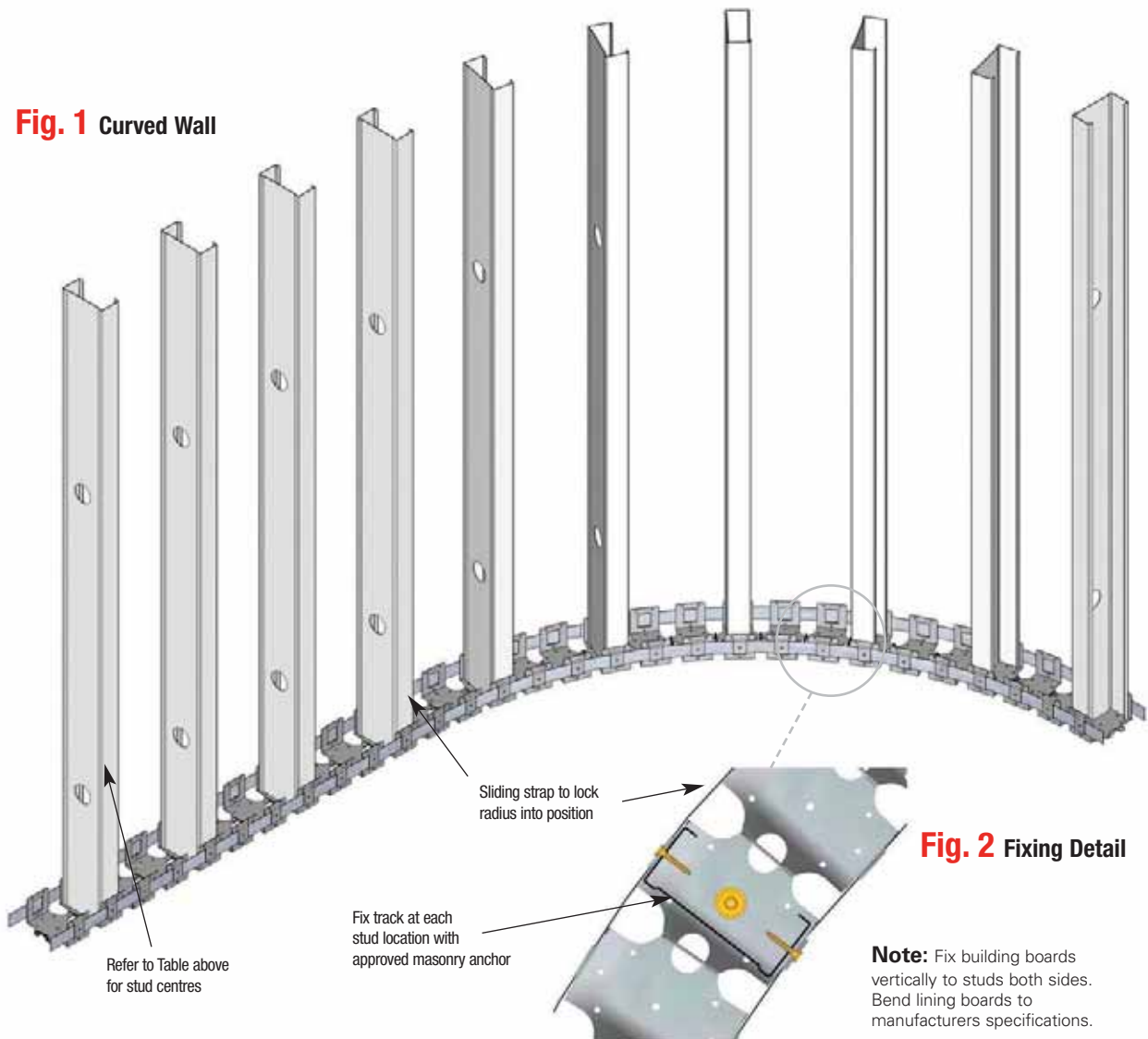


Fig. 2 Fixing Detail

Note: Fix building boards vertically to studs both sides. Bend lining boards to manufacturers specifications.

Installation Guide - HEDA Tough Wall System

The HEDA System from Studco offers an fast and easy way of creating openings in walls in both internal and external applications. Traditionally, wall openings have required two or three studs at each side of the jamb and a series of studs and track to act as a lintel. Whilst this method remains highly popular, the new HEDA System from Studco uses fewer sections and fewer connections, thereby greatly decreasing construction time and simplifying the construction process. The HEDA System consists of only two items. Firstly, there is one new profile, known as the HEDAJamb, which is 92mm wide and 75mm deep, and suits the standard 92mm steel stud system from Studco. Made from galvanised steel, the HEDAJamb is available in 1.2mm and 1.6mm thicknesses, making this section extremely versatile over a vast range of opening sizes. The HEDAJamb section can be used for both the opening jambs (vertical members) and the lintels and sills (horizontal members) and it eliminates the need for using multiple studs and stud/track combinations. Secondly, to connect the HEDAJamb to adjoining members, a new bracket is used, known as the HEDAConnector. This versatile bracket is suitable for all connections required around the openings, eliminating the need for ordering different brackets for different connections. The HEDA System has been fully engineered to meet BCA requirements and Australian Standards, ensuring you of code compliance whenever you use Studco's new HEDA System. The HEDA System is suitable for most opening applications and by discussing your needs with a Studco representative, you can be sure that even your most demanding opening specifications can be accommodated.

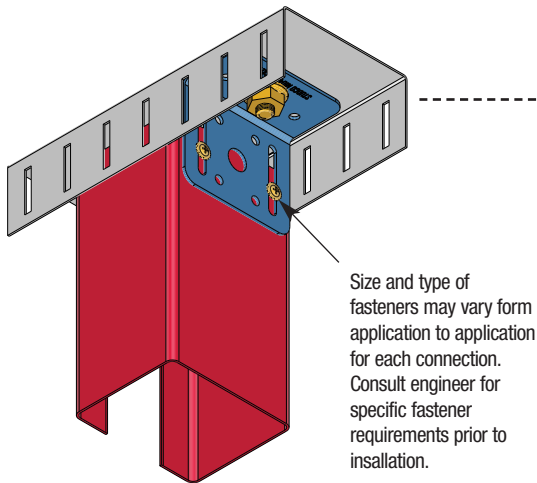


Fig. 1 Jamb Stud To Slotted Deflection Track Connection

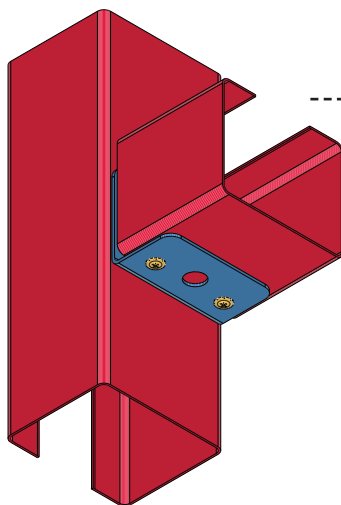


Fig. 2 Jamb Stud To Lintel/Sill Connection

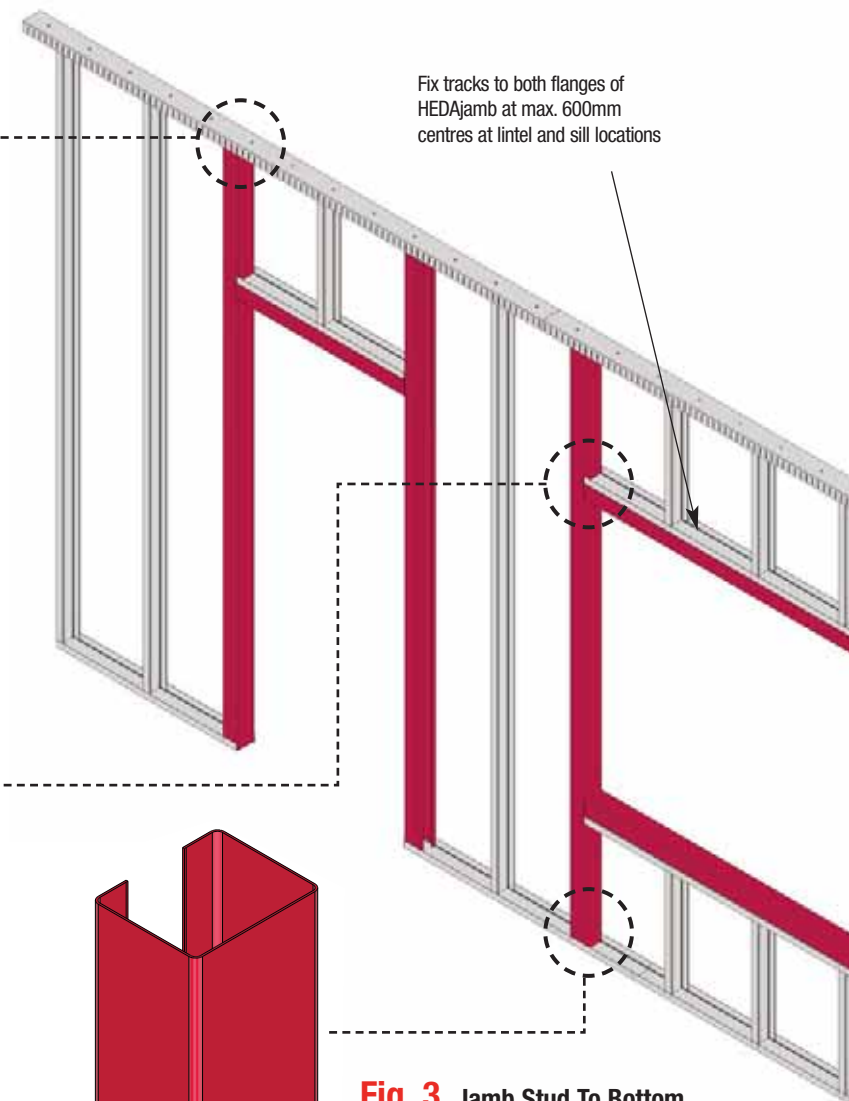
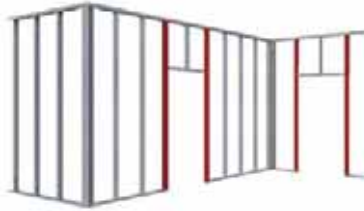


Fig. 3 Jamb Stud To Bottom Track Connection

Studco HEDAjamb is suitable for use in...



Openings in external walls



Openings in internal walls



Construction of extreme walls

Fix studs through slots to allow for building movement (deflection).

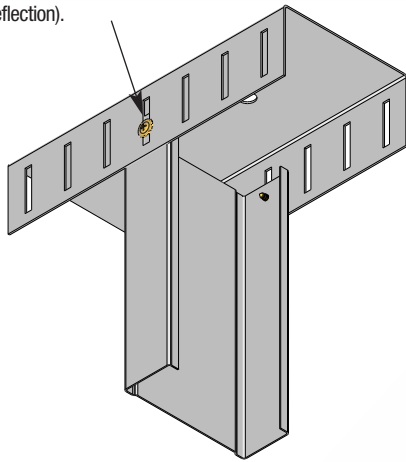
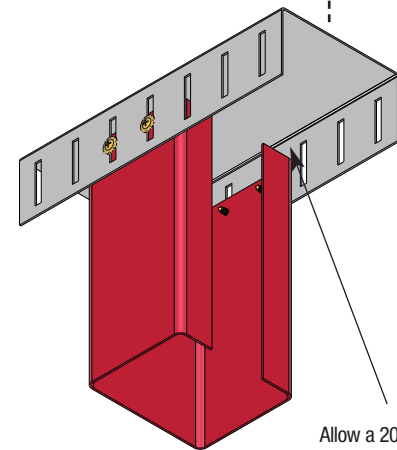
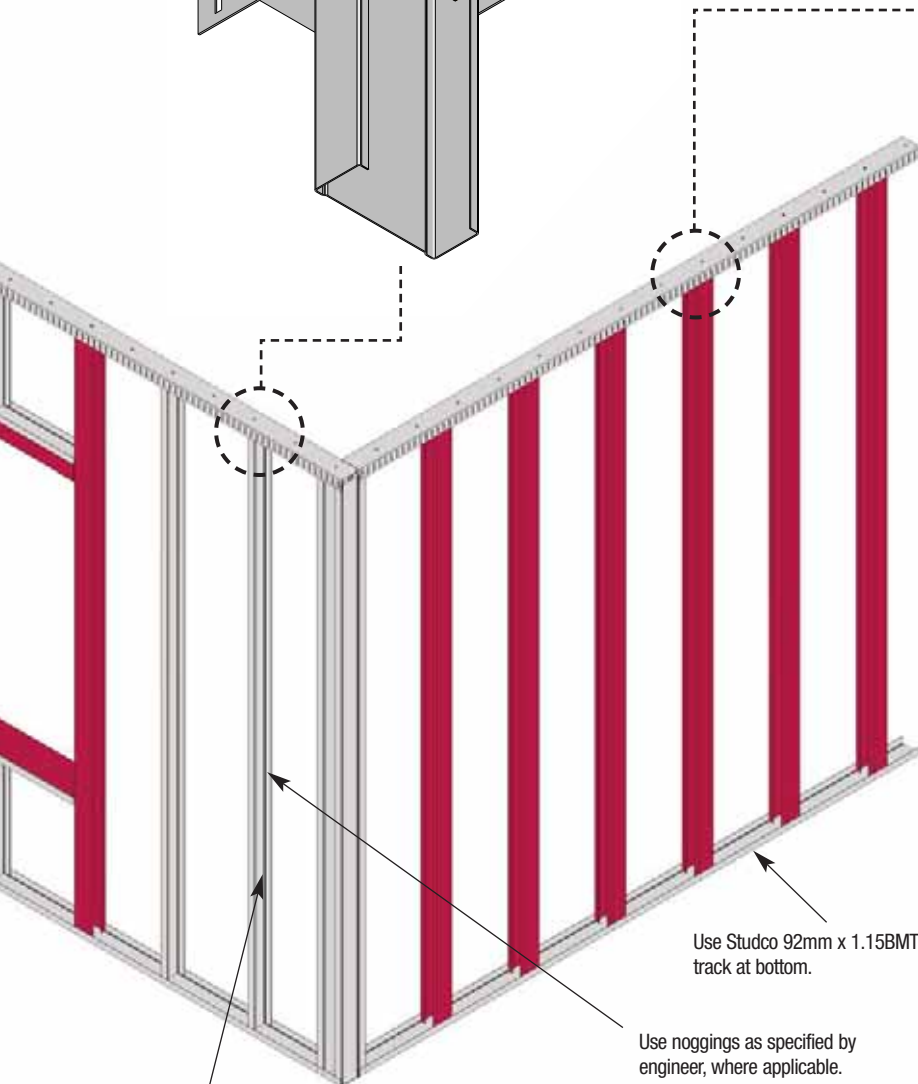


Fig. 4 Wall Stud To Slotted Deflection Track Connection
(Using std stud as wall stud)

* HEDAjamb sections shown in red for illustrative purposes only.

Always ensure tightness of screw is sufficient to allow for deflection if needed.



Allow a 20mm minimum gap between wall studs or jamb studs on top track.

Fig. 5 Wall Stud To Slotted Deflection Track Connection
(Using HEDAjamb as wall stud)

Use Studco 92mm x 1.15BMT steel studs for intermediate wall studs. Consult engineer for spans and spacing.

Use Studco 92mm x 1.15BMT track at bottom.

Use noggings as specified by engineer, where applicable.

CONSULT STUDCO FOR WALL DESIGNS & SPECIFICATIONS

Steel Stud Systems

Installation Guide - Electrical & Plumbing Services

Steel Stud Systems

Plumbing pipes such as copper or brass must be isolated from direct contact with steel stud framing. Plastic grommets or lagging should be used to stop water hammer of pipework. Alternatively plumbing pipes can be fixed to flanges of studs where you have a suitable cavity with appropriate saddle clamps.

Electrical wires simply run through pre-punched service holes. Wires must be isolated safely from the steel structure. When drilling extra holes, refer to *Fig. 3* for cutout guidelines. Drilled holes should not exceed 50mm diameter.

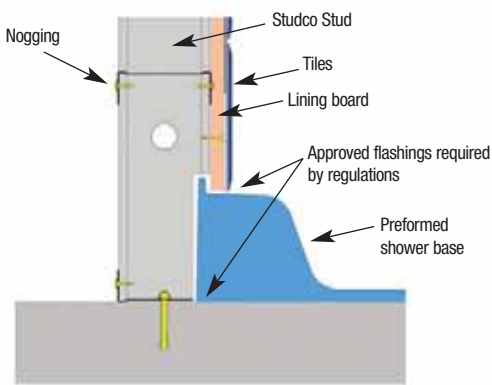


Fig. 1 Showerbase Installation Detail

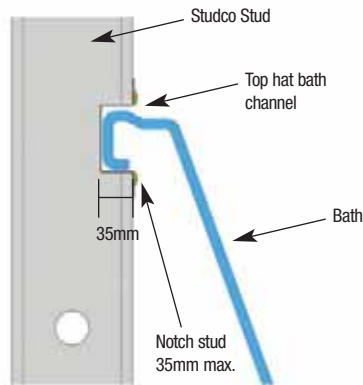


Fig. 2 Bath Notching Detail

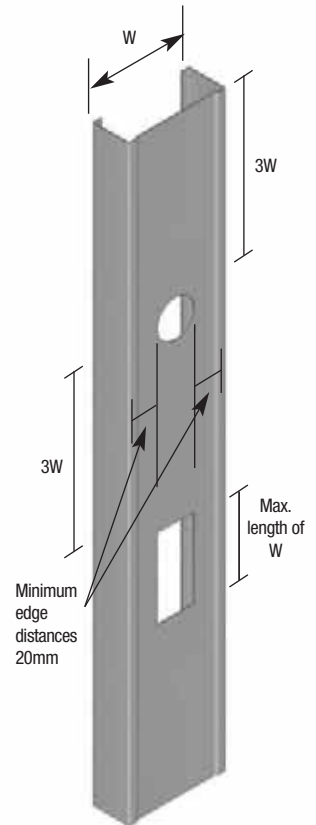


Fig. 3 Stud Cut-Out Guidelines

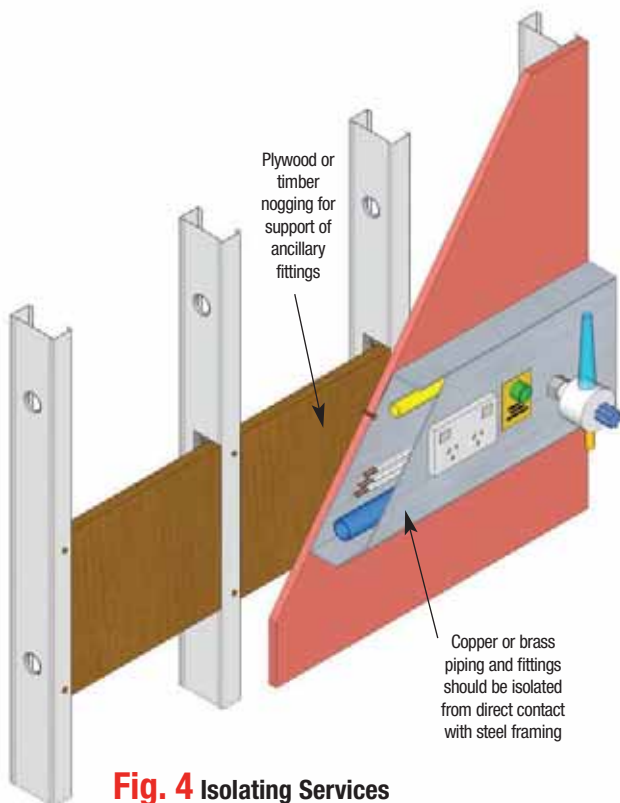


Fig. 4 Isolating Services

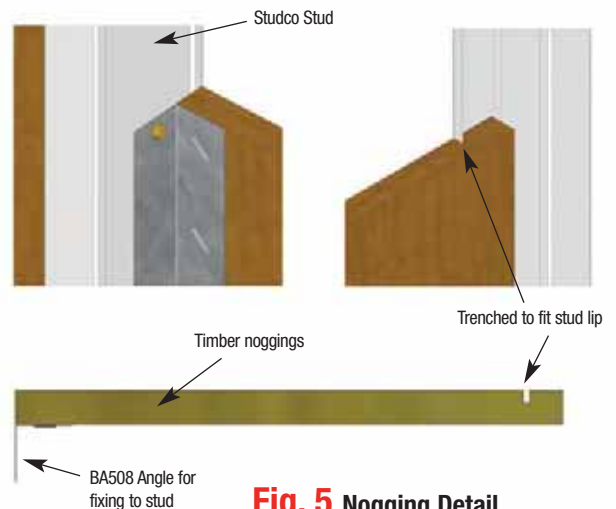


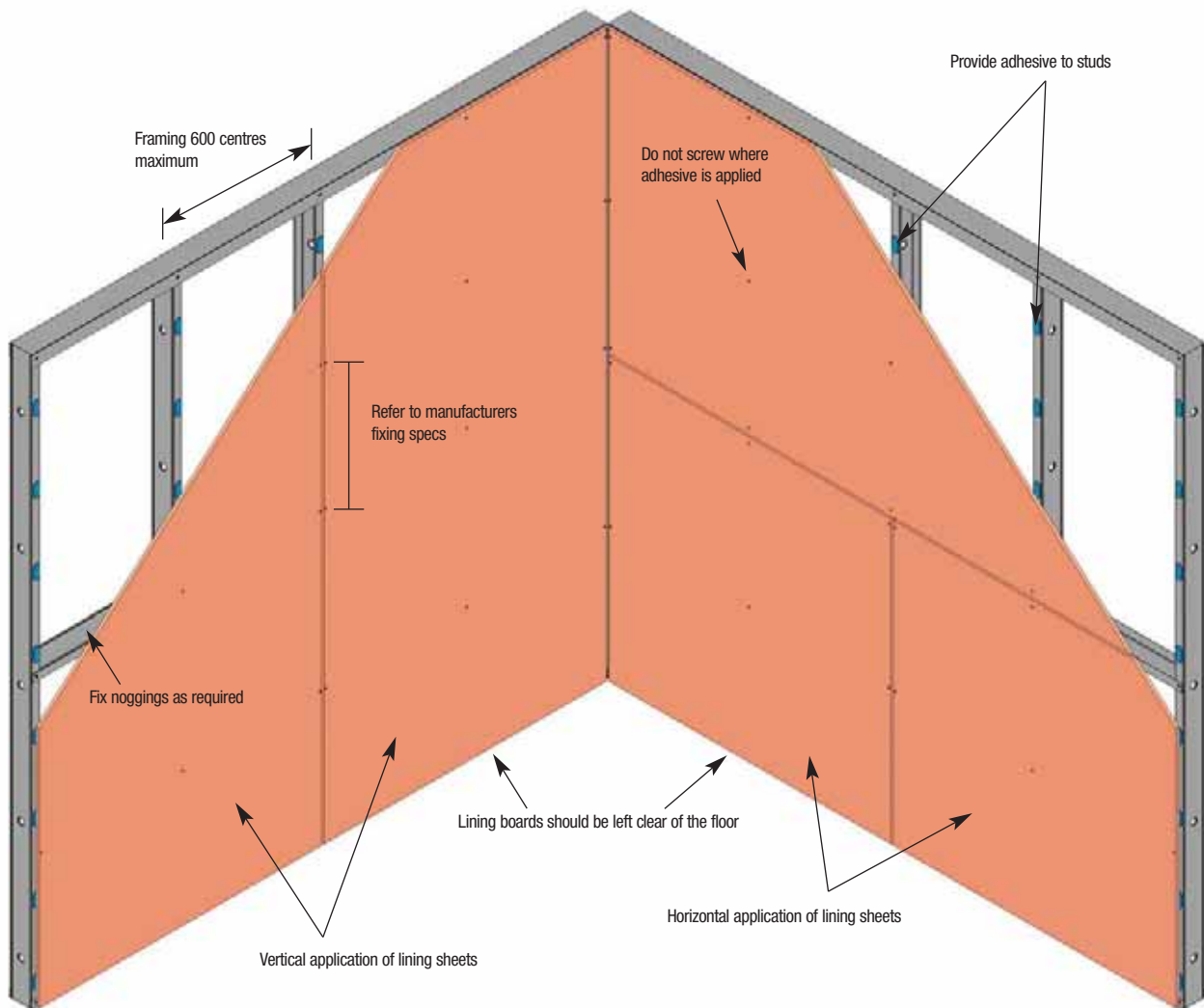
Fig. 5 Nogging Detail

Nogging brackets can also be used for this application - refer to table 49 on page 34

Installation Guide - Lining Boards

Plasterboard linings can be fixed vertically or horizontally with joints staggered alternately either side of the wall. Stud centres should not exceed 600mm centres. Refer to building board and fastener manufacturers specifications for fixing details.

Fig. 1 Lining Boards



Note:

For expansion joints, refer to building board manufacturers recommendations. Also see page 16.

Installation Guide - Chase Walls

Chase walls are required where services have to be accommodated or a discontinuous structure is needed for acoustic purposes. Chase walls are constructed as two separate walls using steel stud and track sections and cross braced at regular intervals with steel stud or track section (see Fig. 1). Where a chase wall is required for acoustic purposes the M24R resilient joiner bracket may be used as bracing. Consult Studco Technical Services for project requirements. Noggings are required based on a chase wall being classed as a wall lined one side. The maximum wall heights can be determined from Table 61.

Fig. 1 Typical Chase Wall Application

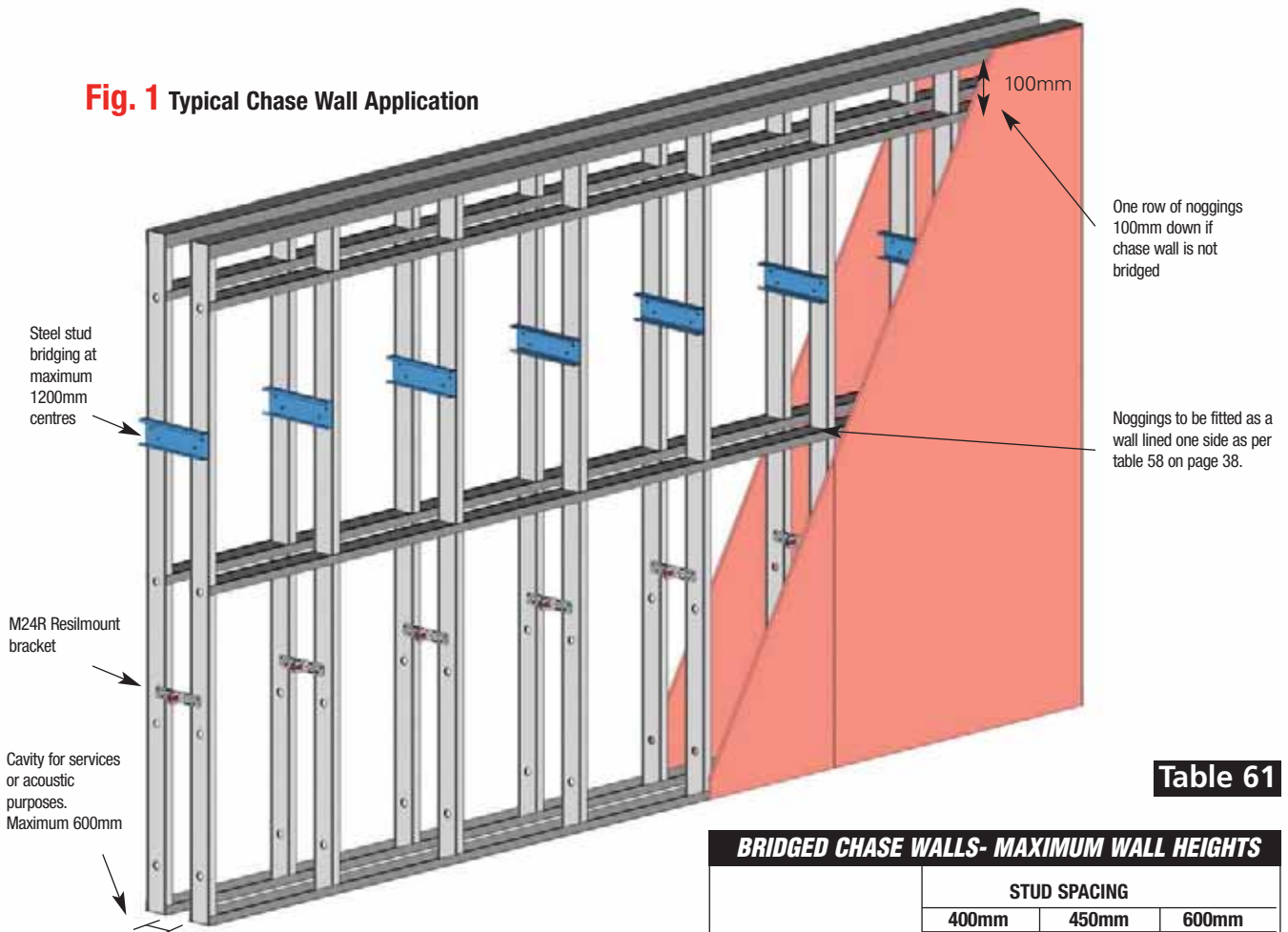


Table 61

BRIDGED CHASE WALLS- MAXIMUM WALL HEIGHTS			
STUD SIZE	STUD SPACING		
	400mm	450mm	600mm
	MAXIMUM WALL HEIGHTS - L/360		
64mm x 0.55BMT	3715mm	3503mm	3033mm
64mm x 0.75BMT	5077mm	4787mm	4145mm
76mm x 0.55BMT	4460mm	4205mm	3642mm
76mm x 0.75BMT	5659mm	5336mm	4621mm
92mm x 0.55BMT	4987mm	4702mm	4072mm
92mm x 0.75BMT	6324mm	5962mm	5163mm

Notes:
 1. Noggings to be equally spaced over wall height
 2. Deflection limit limited to L/360 or L/240 at 0.25kPa in accordance with the BCA spec C1.8
 3. Unbridged walls must be installed with deflection track and an additional row of noggings 100mm down from top of wall.

Fig. 2 Max distance between walls with Resilimount brace

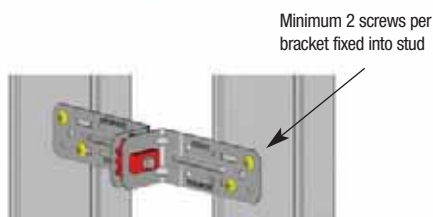
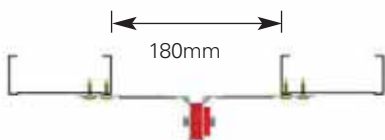


Fig. 3 Max distance between walls with Resilimount brace

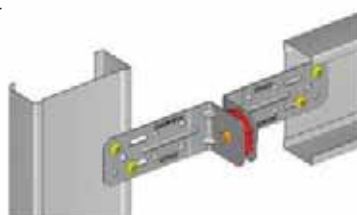


Fig. 4 Larger chase wall cavities use bridging extension.

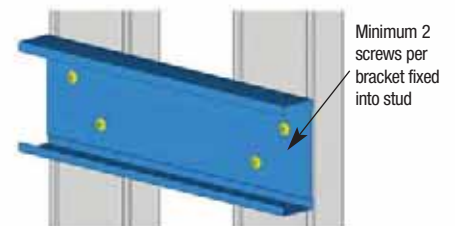


Fig. 5 Steel stud bridging

Installation Guide - Stud Ceilings

When constructing ceilings, steel studs acting as joists can be used where it is impractical to use a concealed suspended ceiling. Applications include many areas, such as apartments, corridors and bathrooms etc. Where service hatches or access locations are within ceilings this area must be strengthened for service trades.

Refer to pages 58/59 for steel stud spans and bridging. Installation and fixing procedures refer to diagrams below.

Fig. 1 Typical Stud Ceiling Application

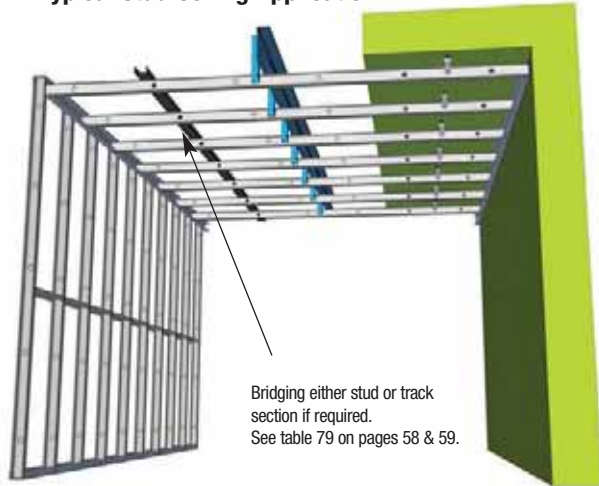


Fig. 2 Stud Joist to Wall Track Fixing Masonry

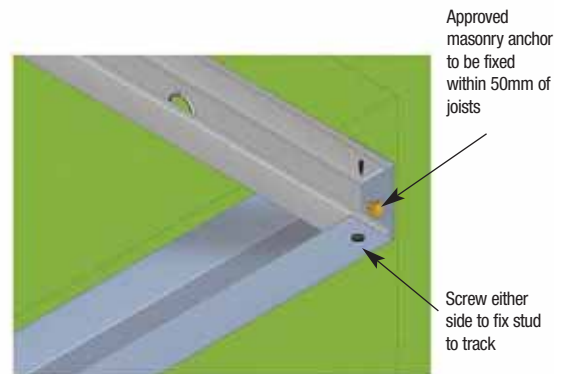


Fig. 3 Stud Joist to Wall Track Fixing

Note:
Where ceiling intersects a stud wall, the wall must be checked for the ceiling load

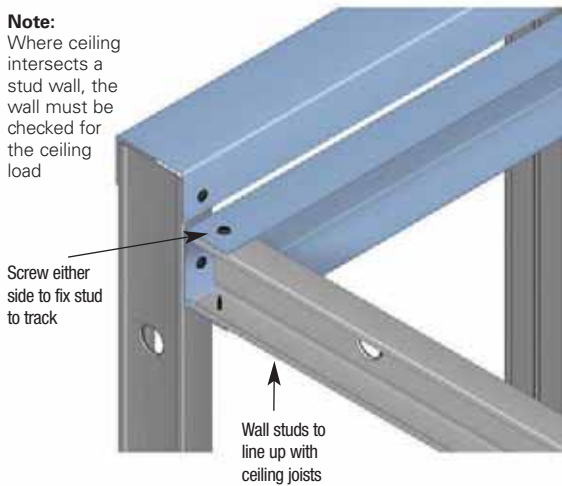


Fig. 4 Stud Joist Suspension Fixing 1

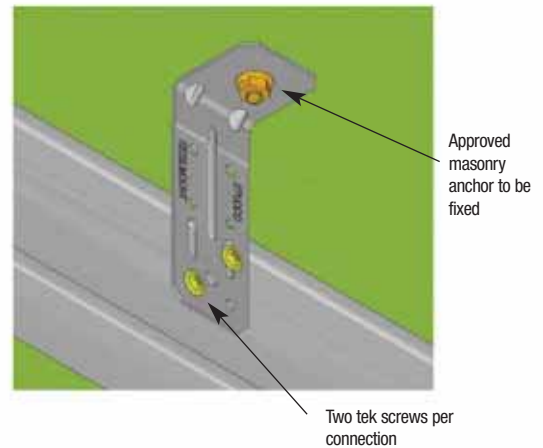
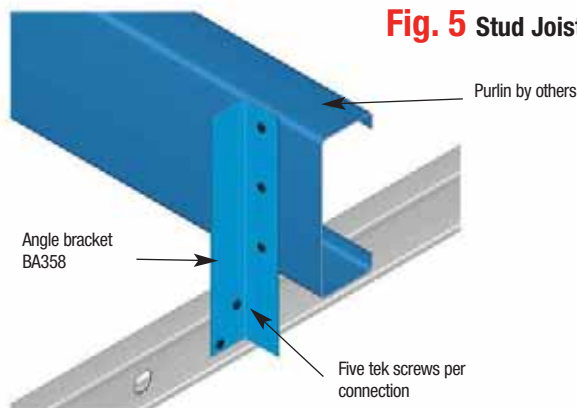


Fig. 5 Stud Joist Suspension Fixing 2



Note:
Refer to fastener manufacturers for fixings.

Note:
Fixings should be made to the web of the purlin unless otherwise approved by an engineer.

Installation Guide - Bulkheads

Bulkheads can be constructed using steel stud and track where furring channels become impractical. Bulkhead stud members will need to be fixed and braced to suitable structural supports, and ensure that the bulkheads meet required design loadings. Design loadings and specifications should be referred by a structural engineer or Studco Technical Services. An economical alternative to constructing bulkheads on-site is to use pre-fabricated modules. Studco can analyse comprehensive plans and reach innovative solutions for framing requirements with any architectural style. The possibilities include circular, curved, stepped or cantilevered framing which is easily suspended from slab or structure by using springhanger Part No. M534 subject to engineers approval. (See Fig 4). Spring hangers to be used only for preliminary suspension before bracing back to structure.

Fig. 1 Ceiling Bulkhead

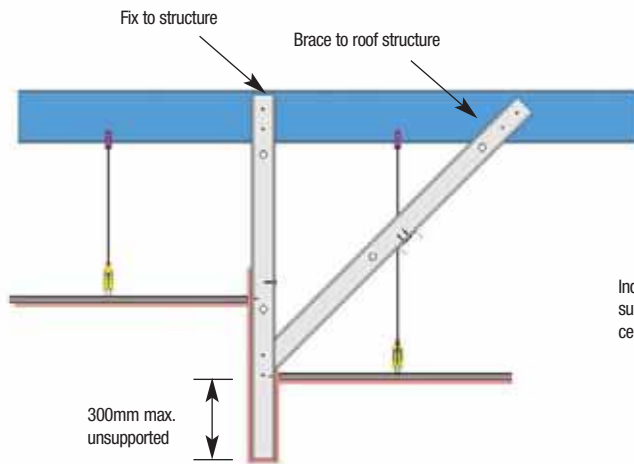


Fig. 2 Ceiling Bulkhead Bracing Detail

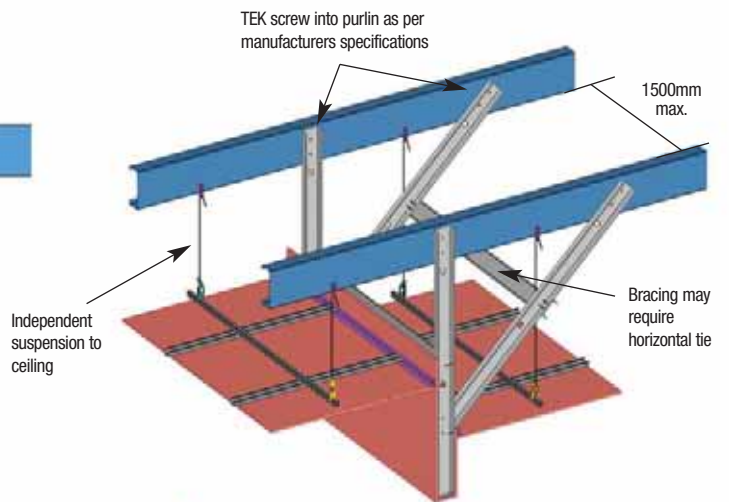


Fig. 4 M534 Spring Hanger Suspension

M534 Spring hanger can be used for preliminary bulkhead suspension for initial installation, then support with bracing back to structure



Fig. 5 Suspension of Prefabricated Bulkheads

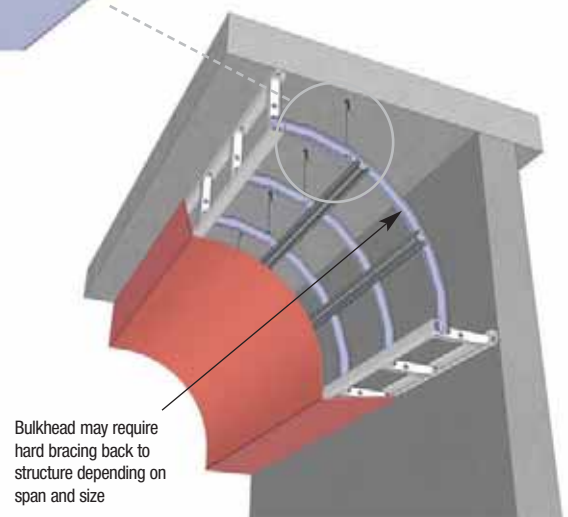
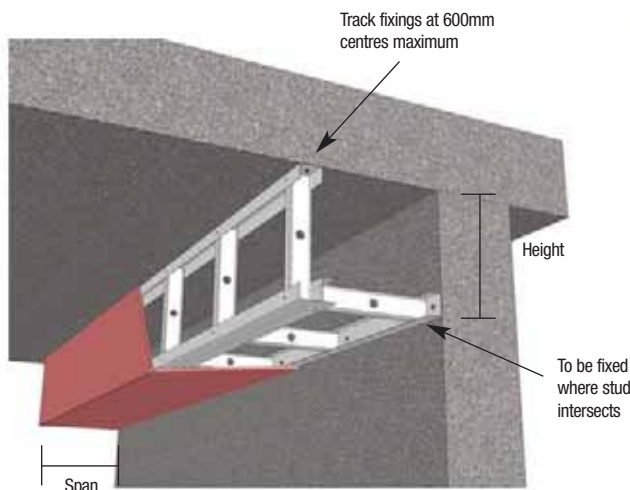


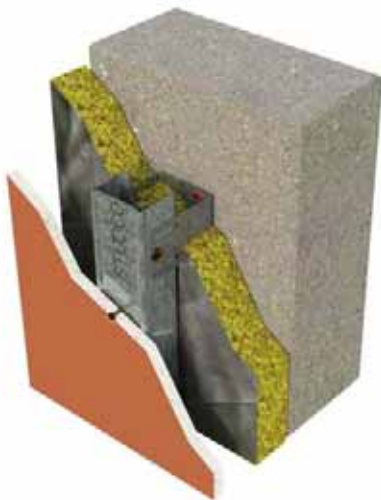
Fig. 3 Box Bulkhead



Installation Guide - Slimwall



The Studco SLIMWALL system is a energy efficient wall system that is code compliant to NCC 2011 Section J (BCA 2011) Energy Efficiency criteria. The Studco SLIMWALL System consists of a C-channel section and a series of two brackets, designed to provide adjustable stand-off points for fixing the channel. The M163-6 SLIMWALL bracket is suitable for wall cavities 69-92mm and the M163-8 SLIMWALL bracket is suitable for wall cavities 85-108mm. Once the M163 brackets are fixed to external wall using shot pins or masonry anchors, the Studco Slimceil M355 channel are inserted into the brackets and screwed to the brackets, achieving a secure and permanent fixing which can support a wide variety of lining board types and weights. So whether you're chasing 6 Star Green Star on your next project or you just need a fast, flexible and fully code compliant wall system, choose the unique, new Studco SLIMWALL.



Studco Slimwall system used with CSR Bradford foil-faced builders blankets to achieve R2.8 rating.



Studco Slimwall system used with foilboard insulation to achieve R1.8 rating.

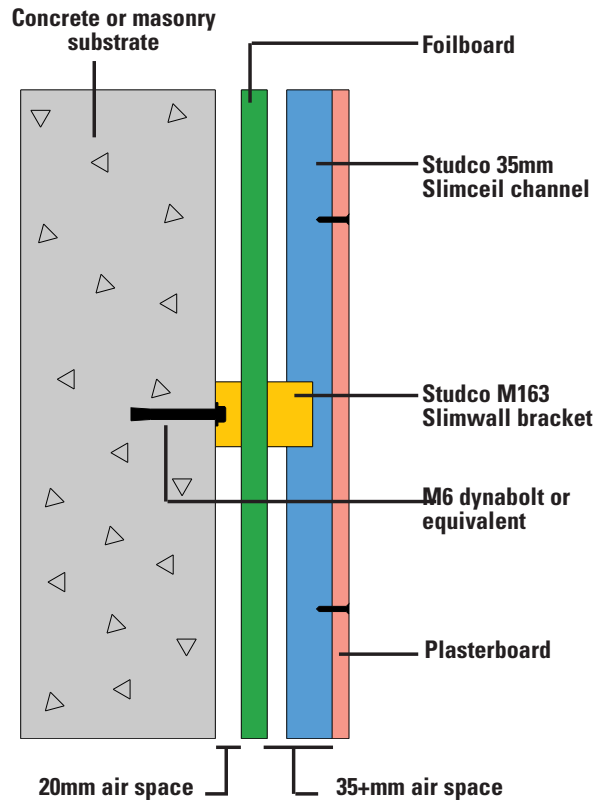


Table 62

SLIMWALL - MIN & MAX MEASUREMENTS			
PART No	BRACKET SIZE	Min measurement	Max measurement
Distance from substrate to back of plasterboard.			
M163-6	68mm	70mm	90mm
M163-8	84mm	86mm	106mm

* This is the distance from the concrete substance and to the back face of the plasterboard lining.

Installation Guide - Strongarm



Steel Stud Systems

The Studco StrongArm™ structural wall brace is designed for rapid in-wall strengthening of free-standing steel stud walls commercial applications, where a structural member is required to limit deflection and improve rigidity. Made from 12mm thick steel and protected by a hot-dip galvanised coating, this super bracket can withstand extreme loads, is suitable for internal and external applications and is sure to save you time and money on your next project. Typical applications include; Free-standing walls, Balustrades, Nib walls, Bulkheads and Smoke baffles.

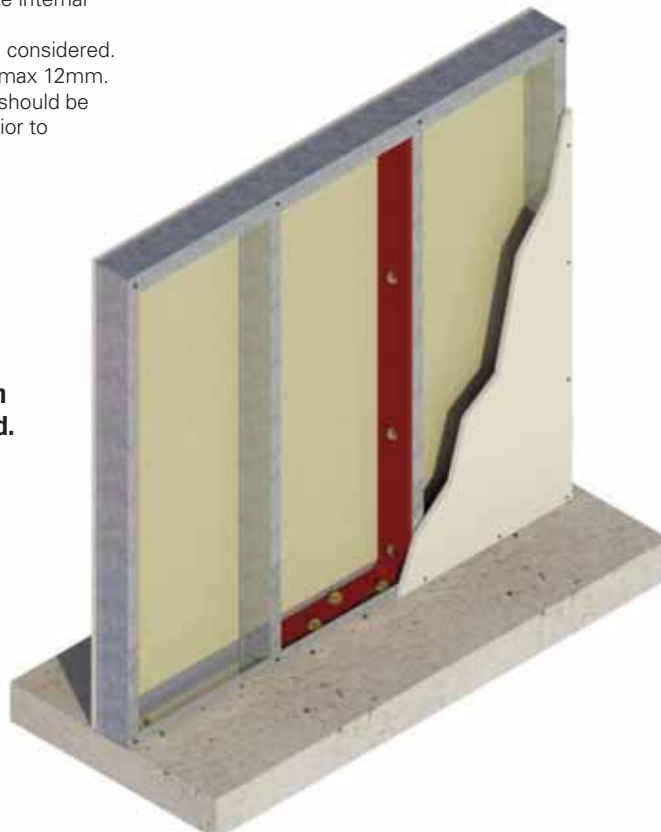
Table 63

Wall Height	STRONGARM - BRACKET/STUD SPACING	
600mm	Wall Stud type and Stud centres	Studco S92075 92mm x 0.75BMT lipped wall stud at 600mm centres
	M110 Bracket Spacing	Maximum 2400mm centers
900mm	Wall Stud type and Stud centres	Studco S92075 92mm x 0.75BMT lipped wall stud at 600mm centres
	M110 Bracket Spacing	Maximum 1800mm centers
1200mm	Wall Stud type and Stud centres	Studco S92075 92mm x 0.75BMT lipped wall stud at 600mm centres
	M110 Bracket Spacing	Maximum 1800mm centers
1500mm	Wall Stud type and Stud centres	Studco S92115 92mm x 1.15BMT lipped wall stud at 600mm centres
	M110 Bracket Spacing	Maximum 1800mm centers
1800mm	Wall Stud type and Stud centres	Studco S92115 92mm x 1.15BMT lipped wall stud at 450mm centres
	M110 Bracket Spacing	Maximum 1800mm centers
2100mm	Wall Stud type and Stud centres	Studco S92115 92mm x 1.15BMT lipped wall stud at 450mm centres
	M110 Bracket Spacing	Maximum 1350mm centers
2400mm	Wall Stud type and Stud centres	Studco S92115 92mm x 1.15BMT lipped wall stud at 450mm centres
	M110 Bracket Spacing	Maximum 900mm centers

Notes:

1. Use Minimum 4No x 12mm masonry anchors with minimum 60mm embedment into concrete is required to fix the bracket to the substrate.
2. The design is for max 0.4kpa Ultimate internal pressure.
3. The Live impact load of 0.75kN been considered.
4. The absolute deflection is limited to max 12mm.
5. All specifications and design criteria should be confirmed by the project engineer prior to installation.

M110 Strongarm bracket installed.



Section Properties & Dimensions - Wall Studs

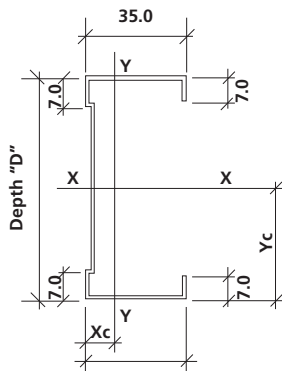
Table 64

SECTION PROPERTIES - STUDS										
Section	BMT mm	Area mm ²	Ixx mm ⁴ x1E3	Iyy mm ⁴ x1E3	Zxx mm ³	Zyy mm ³	rx mm	ry mm	Iw mm ⁶ x1E6	J mm ³
S51050	0.50	63.50	30.618	11.280	1213	528	21.96	13.33	6.360	5.29
S64050	0.50	70.00	50.016	12.135	1588	538	26.73	13.17	10.004	5.83
S64075	0.75	105.00	75.024	18.070	2382	803	26.73	13.12	15.007	19.69
S64115	1.15	161.00	115.037	27.386	3652	1222	26.73	13.04	23.010	70.97
S76055	0.55	84.15	83.103	14.133	2196	600	31.43	12.96	16.258	8.49
S76075	0.75	114.75	113.323	19.156	2994	815	31.43	12.92	22.170	21.52
S76115	1.15	175.95	173.762	29.017	4591	1240	31.43	12.84	33.994	77.56
S92055	0.55	92.95	127.904	14.972	2796	610	37.10	12.69	24.578	9.37
S92075	0.75	126.75	174.414	20.288	3812	828	37.10	12.65	33.515	23.77
S92115	1.15	194.35	267.435	30.718	5846	1259	37.10	12.57	51.390	85.68
S15007	0.75	171.00	549.611	23.126	7353	857	56.69	11.63	100.832	32.06
S15012	1.15	262.20	842.736	34.981	11274	1302	56.69	11.55	154.609	115.59

Material Specifications

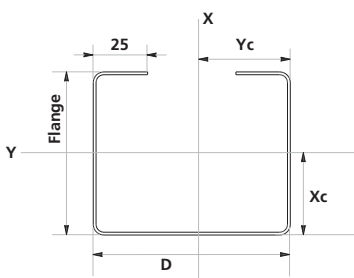
The sections are cold formed from zinc coated steel strip manufactured to AS 1397. Each component having the following properties:
 Steel Grade G2
 Yield strength 300 MPa

Table 65



SECTION DIMENSIONS - STUDS						
Part No.	D	Flange	Lips	BMT	Xc	Yc
S51050	50.8	35.0	7.0	0.50	12.84	25.40
S64050	63.5	35.0	7.0	0.50	11.75	31.75
S64075	63.5	35.0	7.0	0.75	11.81	31.75
S64115	63.5	35.0	7.0	1.15	11.92	31.75
S76055	76.2	35.0	7.0	0.55	10.89	38.10
S76075	76.2	35.0	7.0	0.75	10.95	38.10
S76115	76.2	35.0	7.0	1.15	11.07	38.10
S92055	92	35.0	7.0	0.55	9.92	46.00
S92075	92	35.0	7.0	0.75	9.98	46.00
S92115	92	35.0	7.0	1.15	10.11	46.00
S15007	150	35.0	7.0	0.75	7.59	75.00
S15012	150	35.0	7.0	1.15	7.73	75.00

Table 66

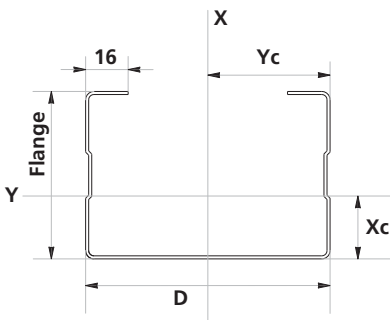


SECTION DIMENSIONS - HEDA						
Part No.	D	Flange	Lips	BMT	Xc	Yc
HJ9289155 [†]	92	89.9	25.4	1.55	41.33	46.0

HEDA Jamb90

FULL SECTION PROPERTIES - HEDA										
Part No.	BMT mm	Area mm ²	Ixx 10 ³ mm ⁴	Iyy 10 ³ mm ⁴	Zxx 10 ³ mm ³	Zyy 10 ³ mm ³	rx mm	ry mm	Iw 10 ⁶ mm ⁶	J mm ³
HJ9289155 [†]	1.55	479.69	730.1	553.5	15.7	12.03	39.014	33.968	1280	384.15

Table 67



SECTION DIMENSIONS - HEDA						
Part No.	D	Flange	Lips	BMT	Xc	Yc
HJ9263150	92	63	16	1.50	23.65	46
HJ15063115	150	63	16	1.15	19.34	75

HEDA Jamb63

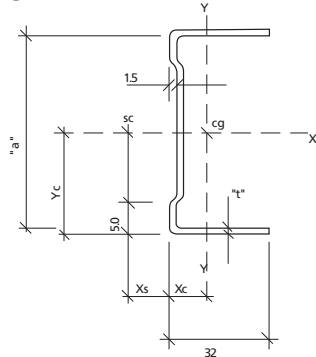
FULL SECTION PROPERTIES - HEDA										
Part No.	BMT mm	Area mm ²	Ixx 10 ³ mm ⁴	Iyy 10 ³ mm ⁴	Zxx 10 ³ mm ³	Zyy 10 ³ mm ³	rx mm	ry mm	Iw 10 ⁶ mm ⁶	J mm ³
HJ9263150	1.5	367	538.9	207.7	11.9	5.41	38.31	23.78	419.6	275
HJ15063115	1.15	350	1268.2	192	17.04	4.46	60.21	23.43	889.5	154

Notes:

1. Section properties are approximate only and may be subject to revision.
2. Section properties tabulated are gross section properties.
3. The strength and serviceability section capacities are based on effective section properties calculated in accordance with AS 4600 "Cold Formed Steel Structures Code."
4. *Steel Grade G450. †Steel Grade G300. Jamb90 Steel Grade G300.

Section Properties & Dimensions - Track

C Channel Track



Material Specifications

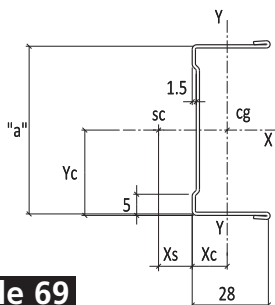
The sections are cold formed from zinc coated steel strip manufactured to AS 1397. Each component having the following properties

Steel Grade G2
Yield strength 300 MPa
Coating class Z275

Table 68

C CHANNEL TRACK																
Dimensions					Gross Area	2nd Moment of Area		Section Modulus		Radius of Gyration		Form Factor	B	Torsion Constant	Warping Constant	
a	BMT	t	Xc	Xs	Xo	Ixx	Iyy	Zxx	Zyy	rxx	ryy	Q	B	J	Iw	
mm	mm	mm	mm	mm	mm	10 ³ mm ⁴	10 ³ mm ⁴	10 ³ mm ³	10 ³ mm ³	mm	mm		mm	mm ⁴	10 ⁶ mm ⁶	
51	0.55		8.53	11.53	20.06	61.05	27.880	5.323	1.072	0.244	21.37	9.34	0.47	62.73	6.16	2.66
64	0.55		7.92	10.92	18.84	67.10	46.22	5.644	1.422	0.252	26.25	9.17	0.44	69.94	6.77	4.49
76	0.55		7.25	10.36	17.61	74.8	70.325	5.903	1.803	0.256	30.66	8.88	0.40	81.35	7.54	6.89
92	0.55		6.64	9.75	16.39	83.60	108.79	6.129	2.314	0.260	36.07	8.59	0.36	97.83	8.43	10.67
51	0.75		8.48	11.50	19.98	83.25	37.59	7.216	1.445	0.329	21.25	9.31	0.58	62.55	15.61	3.56
64	0.75		7.88	10.88	18.76	91.50	62.43	7.652	1.921	0.340	26.12	9.15	0.55	69.72	17.16	6.02
76	0.75		7.21	10.33	17.53	102.0	95.108	8.006	2.438	0.345	30.54	8.86	0.50	81.09	19.13	9.25
92	0.75		6.61	9.72	16.32	114.0	147.28	8.359	3.133	0.351	35.94	8.56	0.45	97.51	21.38	14.35
150	0.75		5.16	7.95	13.12	159.0	485.87	9.208	6.309	0.365	55.28	7.61	0.33	186.41	29.81	45.58
51	1.0		8.42	11.45	19.87	111.0	49.419	9.551	1.900	0.432	21.1	9.28	0.70	62.30	37.00	4.65
64	1.0		7.82	10.83	18.65	122.0	82.261	10.131	2.531	0.446	25.97	9.11	0.67	69.45	40.67	7.87
76	1.0		7.16	10.28	17.44	136.0	125.497	10.602	3.217	0.454	30.38	8.83	0.61	80.75	45.33	12.11
92	1.0		6.56	9.61	16.23	152.0	194.602	11.071	4.140	0.462	35.78	8.53	0.56	97.09	50.67	18.81
150	1.0		5.13	7.91	13.04	212.0	643.75	12.200	8.360	0.480	55.10	7.59	0.42	185.53	70.67	59.86
76	1.15		7.13	10.25	17.38	156.4	143.42	12.143	3.677	0.577	30.28	8.81	0.68	80.54	68.95	13.76
92	1.15		6.54	9.64	16.18	174.8	222.57	12.681	4.735	0.527	35.68	8.52	0.62	96.83	77.06	21.40
150	1.15		5.11	7.89	13.00	243.8	737.52	13.97	9.578	0.548	55.00	7.57	0.46	184.99	107.48	68.22

C Channel Hemmed Track



Material Specifications

The sections are cold formed from zinc coated steel strip manufactured to AS 1397. Each component having the following properties

Steel Grade G2
Yield strength 300 MPa
Coating class Z275

Table 69

C CHANNEL HEMMED TRACK															
Dimensions					Gross Area	2nd Moment of Area		Section Modulus		Radius of Gyration		By	Torsion Constant	Wrapping Constant	
a	BMT	Xc	Xs	Xo	Ixx	Iyy	Zxx	Zyy	rxx	ryy	B	J	Iw		
mm	mm	mm	mm	mm	mm ²	10 ³ mm ⁴	10 ³ mm ⁴	10 ³ mm ³	10 ³ mm ³	mm	mm	mm	mm ⁴	10 ⁶ mm ⁶	
64	0.5	8.28	8.13	16.41	63.24	43.267	5.043	1.331	0.271	26.16	8.93	69.88	5.3	3.42	
76	0.5	7.74	7.6	15.34	69.24	63.818	5.255	1.658	0.275	30.36	8.71	81.58	5.79	5.07	
92	0.5	7.15	6.973	14.123	77.24	99.05	5.486	2.130	0.279	35.81	8.43	104.57	6.46	7.89	

Notes:

- Section properties are approximate only and may be subject to revision.
- Section properties tabulated are gross section properties.
- The strength and serviceability section capacities are based on effective section properties calculated in accordance with AS 4600 "Cold Formed Steel Structures Code".

Section Properties & Dimensions - Deflection Track

Deflection Head Track

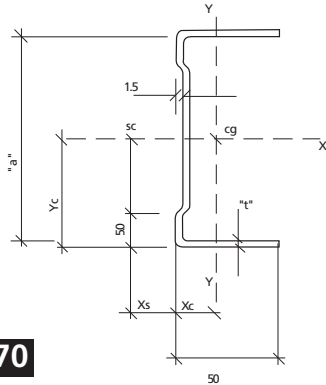


Table 70

Material Specifications

The sections are cold formed from zinc coated steel strip manufactured to AS 1397. Each component having the following properties

Steel Grade G2
 Yield strength 300 MPa
 Coating class Z275

DEFLECTION HEAD TRACK																
Dimensions					Gross Area	2nd Moment of Area		Section Modulus		Radius of Gyration		Form Factor	By	Torsion Constant	Warping Constant	
a	BMT	t	Xc	Xs	Xo	mm ²	lxx	lyy	Zxx	Zyy	rxx	ryy	Q	mm	J	Iw
mm	mm	mm	mm	mm	mm ⁴		mm ⁴	10 ³ mm ³	10 ³ mm ³	mm	mm	mm ⁴	10 ⁶ mm ⁶			
64	0.55	15.91	20.73	36.65	90.2	68.761	23.819	2.128	0.693	27.61	16.25	0.33	96.61	9.10	18.22	
76	0.55	14.94	20.04	34.97	96.8	102.200	25.138	2.640	0.711	32.49	16.11	0.31	101.6	9.76	27.59	
92	0.55	13.81	19.24	33.05	105.6	154.760	26.530	3.320	0.727	38.28	15.85	0.29	110.60	10.65	42.51	
150	0.55	11.05	16.77	27.81	136.4	469.750	30.150	6.215	0.768	58.69	14.87	0.23	162.53	13.75	132.0	
64	0.75	15.98	20.77	36.76	123.0	94.550	32.610	2.910	0.948	27.73	16.28	0.41	96.69	23.06	25.16	
76	0.75	15.00	20.08	35.08	132.0	140.33	34.414	3.615	0.972	32.61	16.15	0.39	101.69	24.75	38.05	
92	0.75	13.88	19.27	33.15	144.0	212.37	36.32	4.54	0.994	38.40	15.88	0.36	110.69	27.00	58.57	
150	0.75	11.09	16.81	27.90	186.0	643.42	41.59	8.493	1.050	58.82	14.89	0.29	162.64	34.88	181.00	
64	1.0	16.07	20.82	36.89	164.0	127.410	43.720	3.89	1.270	27.89	16.33	0.50	96.79	54.67	34.07	
76	1.0	15.09	20.12	35.21	176.0	188.830	46.110	4.830	1.302	32.75	16.19	0.48	101.79	58.67	51.46	
92	1.0	13.95	19.32	33.27	192.0	285.42	48.65	6.072	1.331	38.56	15.92	0.45	110.81	64.00	79.11	
150	1.0	11.15	16.85	28.00	248.0	862.638	55.243	11.35	1.403	58.98	14.93	0.36	162.77	82.67	244.0	
64	1.15	16.13	20.85	36.97	188.0	147.44	50.43	4.480	1.460	27.96	16.35	0.56	96.84	83.14	39.56	
76	1.15	15.14	20.15	35.29	202.4	218.34	53.19	5.562	1.500	32.84	16.21	0.53	101.85	89.22	59.68	
92	1.15	14.00	19.35	33.35	220.80	329.78	56.10	6.990	1.533	38.650	15.94	0.50	110.86	97.34	91.68	
150	1.15	11.19	16.88	28.07	285.20	995.319	63.69	13.070	1.617	59.08	14.94	0.40	162.85	125.73	283.0	

Deflection Head Hemmed Track

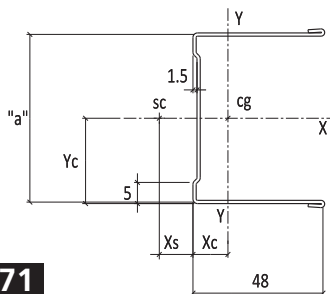


Table 71

Material Specifications

The sections are cold formed from zinc coated steel strip manufactured to AS 1397. Each component having the following properties

Steel Grade G2
 Yield strength 300 MPa
 Coating class Z275

DEFLECTION HEAD HEMMED TRACK															
Dimensions					Gross Area	2nd Moment of Area		Section Modulus		Radius of Gyration		By	Torsion Constant	Warping Constant	
a	BMT	Xc	Xs	Xo	mm ²	lxx	lyy	Zxx	Zyy	rxx	ryy	mm	J	Iw	
mm	mm	mm	mm	mm		10 ³ mm ⁴	10 ³ mm ⁴	10 ³ mm ³	10 ³ mm ³	mm	mm	mm	mm ⁴	10 ⁶ mm ⁶	
64	0.7	14.15	18.57	32.72	132.44	93.371	31.82	2.855	2.435	26.55	15.50	87.85	18.87	19.4	
76	0.7	13.12	17.99	31.11	144.63	137.059	33.465	3.542	2.384	30.78	15.21	92.44	20.24	28.7	
92	0.7	12	17.22	29.22	160.88	211.66	35.271	4.532	2.337	36.27	14.81	100.95	22.07	44.4	

Notes:

- Section properties are approximate only and may be subject to revision.
- Section properties tabulated are gross section properties.
- The strength and serviceability section capacities are based on effective section properties calculated in accordance with AS 4600 "Cold Formed Steel Structures Code".

Span Tables - Internal Stud Wall Heights

Plasterboard

Table 72

MAXIMUM WALL HEIGHTS - LINING BOTH SIDES L/240										
PLASTER THICKNESS (mm)		10mm PLASTERBOARD			13mm PLASTERBOARD			16mm PLASTERBOARD		
STUD SPACING (mm)		300mm	450mm	600mm	300mm	450mm	600mm	300mm	450mm	600mm
PART NO.	STUD SIZE	MAX WALL HEIGHT (mm)								
S51050	51mm x 0.50BMT	3400	3050	2790	3730	3450	3195	3830	3550	3350
S64050	64mm x 0.50BMT	3980	3630	3400	4270	3990	3700	4460	4130	3900
S64075	64mm x 0.75BMT	4550	4150	3900	4750	4400	4200	4930	4600	4350
S64115	64mm x 1.15BMT	4940	4460	4180	5100	4680	4400	5260	4820	4550
S76055	76mm x 0.55BMT	4530	4050	3730	4850	4450	4160	5060	4600	4300
S76075	76mm x 0.75BMT	5250	4750	4450	5650	5250	4920	5850	5460	5100
S76115	76mm x 1.15BMT	5690	5070	4670	6030	5530	5180	6220	5690	5400
S92055	92mm x 0.55BMT	5350	4870	4560	5640	5210	4850	5850	5460	5100
S92075	92mm x 0.75BMT	5920	5280	4850	6250	5750	5480	6490	6050	5650
S92115	92mm x 1.15BMT	6400	5650	5150	6720	6180	5770	6930	6380	5950
S15007	150mm x 0.75BMT	7850	7160	6590	8140	7560	6750	8250	7670	7290
S15012	150mm x 1.15BMT	8590	7760	7280	8760	8040	7590	8900	8180	7710

Table 73

MAXIMUM WALL HEIGHTS - LINING ONE SIDE L/240										
PLASTER THICKNESS (mm)		10mm PLASTERBOARD			13mm PLASTERBOARD			16mm PLASTERBOARD		
STUD SPACING (mm)		300mm	450mm	600mm	300mm	450mm	600mm	300mm	450mm	600mm
PART NO.	STUD SIZE	MAX WALL HEIGHT (mm)								
S51050	51mm x 0.50BMT	2900	2530	2350	2910	2540	2360	2920	2550	2370
S64050	64mm x 0.50BMT	3400	2980	2730	3410	2990	2750	3470	3060	2760
S64075	64mm x 0.75BMT	3950	3450	3180	4020	3540	3250	4060	3560	3280
S64115	64mm x 1.15BMT	4450	3880	3550	4500	3950	3600	4550	3980	3620
S76055	76mm x 0.55BMT	4050	3530	3220	4140	3600	3250	4160	3620	3280
S76075	76mm x 0.75BMT	4500	3950	3600	4700	4100	3750	4730	4180	3800
S76115	76mm x 1.15BMT	5130	4480	4070	5150	4490	4080	5170	4500	4090
S92055	92mm x 0.55BMT	4640	4080	3650	4660	4090	3670	4680	4100	3690
S92075	92mm x 0.75BMT	5200	4540	4150	5290	4610	4190	5320	4630	4220
S92115	92mm x 1.15BMT	5930	5180	4700	5950	5200	4720	5970	5220	4730
S15007	150mm x 0.75BMT	7370	6600	5350	7390	6650	5390	7400	6680	5430
S15012	150mm x 1.15BMT	8300	7450	6850	8320	7480	6880	8350	7500	6900

* See page 37 for noggling requirements.

Notes:

1. Serviceability limits are as stated on tables.
2. Tables 57-60 are for internal non-load bearing walls.
3. Internal design pressures = 0.25 kPa serviceability and 0.375 kPa strength as per BCA 2009.
4. It is assumed the top plate is restrained laterally.
5. Shelf loading has not been allowed for in tabulated wall heights.
6. Noggings to be used in accordance with *Table 58* on page 38.
7. The above wall heights are suitable for up to two layers of the nominated lining thickness.

Span Tables - Internal Stud Wall Heights

Brittle Substrates - (ie. tiles, glass etc.)

Table 74

MAXIMUM WALL HEIGHTS - LINING BOTH SIDES L/360										
PLASTER THICKNESS (mm)		10mm PLASTERBOARD			13mm PLASTERBOARD			16mm PLASTERBOARD		
STUD SPACING (mm)		300mm	450mm	600mm	300mm	450mm	600mm	300mm	450mm	600mm
PART NO.	STUD SIZE	MAX WALL HEIGHT (mm)								
S51050	51mm x 0.50BMT	3050	2750	2570	3340	3070	2910	3360	3150	3050
S64050	64mm x 0.50BMT	3520	3210	3110	3760	3520	3350	3950	3700	3600
S64075	64mm x 0.75BMT	4000	3660	3490	4200	3910	3730	4420	4100	3910
S64115	64mm x 1.15BMT	4330	3940	3680	4500	4150	3920	4680	4300	4060
S76055	76mm x 0.55BMT	4030	3680	3350	4280	3930	3750	4460	4150	3900
S76075	76mm x 0.75BMT	4620	4200	4000	4810	4540	4310	5160	4750	4550
S76115	76mm x 1.15BMT	5000	4520	4210	5260	4820	4580	5480	5040	4800
S92055	92mm x 0.55BMT	4710	4310	4050	4970	4600	4370	5190	4810	4610
S92075	92mm x 0.75BMT	5230	4750	4420	5530	5170	4870	5760	5350	5100
S92115	92mm x 1.15BMT	5700	5090	4670	6000	5440	5150	6190	5640	5350
S15007	150mm x 0.75BMT	7150	6370	5880	7350	6680	6270	7540	6850	6440
S15012	150mm x 1.15BMT	7950	7060	6480	8200	7320	6840	8310	7480	6970

Table 75

MAXIMUM WALL HEIGHTS - LINING ONE SIDE L/360										
PLASTER THICKNESS (mm)		10mm PLASTERBOARD			13mm PLASTERBOARD			16mm PLASTERBOARD		
STUD SPACING (mm)		300mm	450mm	600mm	300mm	450mm	600mm	300mm	450mm	600mm
PART NO.	STUD SIZE	MAX WALL HEIGHT (mm)								
S51050	51mm x 0.50BMT	2520	2240	2020	2540	2260	2040	2560	2280	2060
S64050	64mm x 0.50BMT	2960	2590	2360	2980	2600	2370	3100	2690	2450
S64075	64mm x 0.75BMT	3450	3000	2750	3560	3120	2850	3580	3150	2880
S64115	64mm x 1.15BMT	3880	3400	3100	3970	3490	3170	3990	3510	3190
S76055	76mm x 0.55BMT	3520	3080	2800	3670	3220	2950	3700	3260	2960
S76075	76mm x 0.75BMT	3940	3430	3120	4100	3700	3400	4140	3770	3460
S76115	76mm x 1.15BMT	4460	3890	3550	4470	3900	3570	4480	3910	3590
S92055	92mm x 0.55BMT	4070	3560	3230	4160	3630	3260	4200	3650	3280
S92075	92mm x 0.75BMT	4530	3960	3610	4690	4120	3750	4700	4130	3780
S92115	92mm x 1.15BMT	5160	4520	4100	5250	4580	4150	5300	4600	4160
S15007	150mm x 0.75BMT	6680	5810	5270	6700	5830	5290	6730	5850	5300
S15012	150mm x 1.15BMT	7620	6660	6060	7640	6690	6090	7660	6730	6110

* See page 37 for noggling requirements.

Notes:

1. Serviceability limits are as stated on tables.
2. Tables 57-60 are for internal non-load bearing walls.
3. Internal design pressures = 0.25 kPa serviceability and 0.375 kPa strength as per BCA 2009.
4. It is assumed the top plate is restrained laterally.
5. Shelf loading has not been allowed for in tabulated wall heights.
6. Noggings to be used in accordance with *Table 58* on page 38.
7. The above wall heights are suitable for up to two layers of the nominated lining thickness.

Span Tables - Stud Ceilings - Double Span

Double span studs as ceiling joists - no access (non Trafficable)

Table 80

DOUBLE SPAN STUDS AS CEILING JOISTS - STUD SPACING 300mm												
STUD SIZE	51mm		64mm		76mm			92mm			150mm	
STUD BMT (mm)	0.5	0.5	0.75	1.15	0.55	0.75	1.15	0.55	0.75	1.15	0.75	1.15
PLASTERBOARD LINING	STUD SPACING 300mm											
	MAX STUD CEILING SPAN (mm)											
1 layer 10mm	3090	3480	4100	4600	4100	4600	5170	4550	5150	5870	7040	8170
1 layer 13mm	3030	3410	4110	4580	4050	4700	5150	4480	5200	5800	7050	8260
1 layer 16mm	2950	3280	4000	4400	3920	4600	5050	4340	5130	5730	6870	8080
2 layers 13mm	2780	3100	3840	4290	3710	4420	4910	4090	5020	5600	6690	8010
2 layers 16mm	2640	2890	3650	4100	3420	4250	4630	3800	4750	5330	6290	7810

Table 81

DOUBLE SPAN STUDS AS CEILING JOISTS - STUD SPACING 450mm												
STUD SIZE	51mm		64mm		76mm			92mm			150mm	
STUD BMT (mm)	0.5	0.5	0.75	1.15	0.55	0.75	1.15	0.55	0.75	1.15	0.75	1.15
PLASTERBOARD LINING	STUD SPACING 450mm											
	MAX STUD CEILING SPAN (mm)											
1 layer 10mm	2670	2870	3650	4100	3390	4150	4650	3750	4670	5290	6170	7150
1 layer 13mm	2600	2800	3600	4050	3350	4150	4600	3680	4650	5200	6100	7210
1 layer 16mm	2500	2710	3500	3900	3220	4080	4520	3550	4590	5140	5830	7080
2 layers 13mm	2300	2530	3390	3820	3030	3890	4310	3390	4330	5020	5530	7010
2 layers 16mm	2160	2370	3190	3620	2820	3650	4130	3130	4060	4720	5190	6850

Table 82

DOUBLE SPAN STUDS AS CEILING JOISTS - STUD SPACING 600mm												
STUD SIZE	51mm		64mm		76mm			92mm			150mm	
STUD BMT (mm)	0.5	0.5	0.75	1.15	0.55	0.75	1.15	0.55	0.75	1.15	0.75	1.15
PLASTERBOARD LINING	STUD SPACING 600mm											
	MAX STUD CEILING SPAN (mm)											
1 layer 10mm	2330	2500	3300	3750	2950	3800	4290	3280	4250	4830	5400	7000
1 layer 13mm	2230	2450	3280	3690	2900	3750	4200	3190	4150	4800	5300	6850
1 layer 16mm	2200	2360	3190	3580	2780	3600	4150	3130	4020	4720	5150	6560
2 layers 13mm	2010	2200	3020	3430	2610	3390	3950	2930	3750	4560	4850	6400
2 layers 16mm	1870	2090	2860	3280	2440	3160	4050	2720	3530	4370	4590	6050

Table 83

MINIMUM TOP FLANGE BRIDGING REQUIREMENTS	
Stud Ceiling Span (mm)	Rows of Nogging Bridging
0 - 2500	0
2500 - 4000	1
4000 - 6000	2
6000 - 8000	3

- NOTES:**
- 1) Strength based on 1.2G + Wu Ws - 0.25kPa Wu - 0.375kPa
 - 2) Serviceability based on G Limit Span/480 Max 10mm
W Limit Span/300 Max 12mm
 - 3) Tables based on non trafficable (non accessible) Ceiling space
 - 4) Tables based on plaster glued and screwed to tension edge.
 - 5) Supporting structures or walls to be independantly checked.
 - 6) Bridging requirements as per *Table 83* (this page) and installation guide on page 49.

Shelf Loadings - Stud Walls

Steel Stud Systems

Table 84

MAXIMUM ALLOWABLE SHELF LOADS- WALL HEIGHT 2400mm							
WALL HEIGHT - 2400mm		NUMBER OF SHELVES SPACED EQUALLY OVER FULL HEIGHT					
STUD SIZE	SHELF WIDTH mm	1	2	3	4	5	6
		MAXIMUM ALLOWABLE SHELF LOAD IN kg PER METRE RUN OF SHELF					
64mm x 0.55BMT	200	122	67	55	51	49	47
	300	81	45	37	34	33	32
	400	61	33	27	26	25	24
64mm x 0.75BMT	200	183	100	82	77	74	71
	300	122	67	55	51	49	47
	400	92	50	41	39	37	36
76mm x 0.55BMT	200	203	111	91	85	82	79
	300	135	74	61	57	55	53
	400	101	55	46	43	41	39
76mm x 0.75BMT	200	277	151	124	116	112	108
	300	184	101	83	78	75	72
	400	138	76	62	58	56	54
76mm x 1.15BMT	200	424	232	190	179	172	165
	300	283	155	127	119	115	110
	400	212	116	95	89	86	83

Table 85

MAXIMUM ALLOWABLE SHELF LOADS- WALL HEIGHT 2700mm							
WALL HEIGHT - 2700mm		NUMBER OF SHELVES SPACED EQUALLY OVER FULL HEIGHT					
STUD SIZE	SHELF WIDTH mm	1	2	3	4	5	6
		MAXIMUM ALLOWABLE SHELF LOAD IN kg PER METRE RUN OF SHELF					
64mm x 0.55BMT	200	109	59	49	46	44	42
	300	72	40	32	30	29	28
	400	54	30	24	23	22	21
64mm x 0.75BMT	200	163	89	73	69	66	63
	300	109	59	49	46	44	42
	400	81	45	37	34	33	32
64mm x 1.15BMT	200	250	137	112	105	101	97
	300	166	91	75	70	67	65
	400	92	50	41	39	37	36
76mm x 0.55BMT	200	180	99	81	76	73	70
	300	120	66	54	51	49	47
	400	90	49	40	38	37	35
76mm x 0.75BMT	200	246	134	110	104	100	96
	300	164	90	74	69	66	64
	400	138	76	62	58	56	54
76mm x 1.15BMT	200	377	206	169	159	153	147
	300	251	137	113	106	102	98
	400	212	116	95	89	86	83

Shelf Loadings - Stud Walls

Table 86

MAXIMUM ALLOWABLE SHELF LOADS- WALL HEIGHT 3000mm							
WALL HEIGHT - 3000mm		NUMBER OF SHELVES SPACED EQUALLY OVER FULL HEIGHT					
STUD SIZE	SHELF WIDTH mm	1	2	3	4	5	6
		MAXIMUM ALLOWABLE SHELF LOAD IN kg PER METRE RUN OF SHELF					
64mm x 0.55BMT	200	98	53	44	41	40	38
	300	65	36	29	27	26	25
	400	49	27	22	21	20	19
64mm x 0.75BMT	200	147	80	66	62	59	57
	300	98	53	44	41	40	38
	400	73	40	33	31	30	28
64mm x 1.15BMT	200	225	123	101	95	91	87
	300	150	82	67	63	61	58
	400	112	61	50	47	45	44
76mm x 0.55BMT	200	162	89	73	68	66	63
	300	108	59	49	46	44	42
	400	81	44	36	34	33	32
76mm x 0.75BMT	200	221	121	99	93	90	86
	300	148	81	66	62	60	57
	400	111	61	50	47	45	43
76mm x 1.15BMT	200	339	186	152	143	137	132
	300	226	124	102	95	92	88
	400	170	93	76	71	69	66

Table 87

MAXIMUM ALLOWABLE SHELF LOADS- WALL HEIGHT 3600mm							
WALL HEIGHT - 3600mm		NUMBER OF SHELVES SPACED EQUALLY OVER FULL HEIGHT					
STUD SIZE	SHELF WIDTH mm	1	2	3	4	5	6
		MAXIMUM ALLOWABLE SHELF LOAD IN kg PER METRE RUN OF SHELF					
76mm x 0.55BMT	200	135	74	61	57	55	53
	300	90	49	40	38	37	35
	400	68	37	30	28	27	26
76mm x 0.75BMT	200	184	101	83	78	75	72
	300	123	67	55	52	50	48
	400	92	50	41	39	37	36
76mm x 1.15BMT	200	283	155	127	119	115	110
	300	189	103	85	79	76	73
	400	141	77	63	60	57	55
92mm x 0.55BMT	200	208	114	93	88	84	80
	300	139	76	62	58	56	54
	400	104	57	47	44	42	40
92mm x 0.75BMT	200	284	155	127	120	115	110
	300	189	104	85	80	77	74
	400	142	78	64	60	57	55
92mm x 1.15BMT	200	435	238	195	183	176	169
	300	290	159	130	122	118	113
	400	218	119	98	92	88	85

Shelf Loadings - Stud Walls

Steel Stud Systems

Table 88

MAXIMUM ALLOWABLE SHELF LOADS- WALL HEIGHT 4200mm							
WALL HEIGHT - 4200mm		NUMBER OF SHELVES SPACED EQUALLY OVER FULL HEIGHT					
STUD SIZE	SHELF WIDTH mm	1	2	3	4	5	6
		MAXIMUM ALLOWABLE SHELF LOAD IN kg PER METRE RUN OF SHELF					
76mm x 0.55BMT	200	116	63	52	49	47	45
	300	77	42	35	33	31	30
	400	58	32	26	24	23	23
76mm x 0.75BMT	200	158	86	71	67	64	61
	300	105	58	47	44	43	41
	400	79	43	35	33	32	31
76mm x 1.15BMT	200	242	133	109	102	98	94
	300	162	88	73	68	65	63
	400	121	66	54	51	49	47
92mm x 0.55BMT	200	178	98	80	75	72	69
	300	119	65	53	50	48	46
	400	89	49	40	38	36	35
92mm x 0.75BMT	200	243	133	109	102	99	95
	300	162	89	73	68	66	63
	400	122	67	55	51	49	47
92mm x 1.15BMT	200	373	204	168	157	151	145
	300	249	136	112	105	101	97
	400	187	102	84	79	76	73

Table 89

MAXIMUM ALLOWABLE SHELF LOADS- WALL HEIGHT 4800mm							
WALL HEIGHT - 4800mm		NUMBER OF SHELVES SPACED EQUALLY OVER FULL HEIGHT					
STUD SIZE	SHELF WIDTH mm	1	2	3	4	5	6
		MAXIMUM ALLOWABLE SHELF LOAD IN kg PER METRE RUN OF SHELF					
76mm x 0.55BMT	200	101	55	46	43	41	39
	300	68	37	30	28	27	26
	400	51	28	23	21	21	20
76mm x 0.75BMT	200	138	76	62	58	56	54
	300	92	50	41	39	37	36
	400	69	38	31	29	28	27
76mm x 1.15BMT	200	212	116	95	89	86	83
	300	141	77	63	60	57	55
	400	106	58	48	45	43	41
92mm x 0.55BMT	200	156	85	70	66	63	61
	300	104	57	47	44	42	40
	400	78	43	35	33	32	30
92mm x 0.75BMT	200	213	116	96	90	86	83
	300	142	78	64	60	57	55
	400	106	58	48	45	43	41
92mm x 1.15BMT	200	326	179	147	137	132	127
	300	218	119	98	92	88	85
	400	163	89	73	69	66	63

Shelf Loadings - Stud Walls

Table 90

MAXIMUM ALLOWABLE SHELF LOADS- WALL HEIGHT 6000mm							
WALL HEIGHT - 6000mm		NUMBER OF SHELVES SPACED EQUALLY OVER FULL HEIGHT					
STUD SIZE	SHELF WIDTH mm	1	2	3	4	5	6
		MAXIMUM ALLOWABLE SHELF LOAD IN kg PER METRE RUN OF SHELF					
92mm x 1.15BMT	200	261	143	117	110	106	102
	300	174	95	78	73	71	68
	400	131	71	59	55	53	51
150mm x 0.75BMT	200	450	250	167	125	100	83
	300	298	196	161	120	95	83
	400	232	147	121	113	90	80
150mm x 1.15BMT	200	650	400	370	346	320	267
	300	475	300	246	231	222	213
	400	368	225	185	173	167	160

Design Parameters and Assumptions

Preparation of the Shelf load Tables have been based on the following assumptions.

1. Max Stud Spacing - 600mm.
2. Top and bottom wall tracks are mechanically fixed to floor and ceiling framing.
3. Studs are mechanically fixed to top and bottom wall tracks.
4. Studs and track sections are manufactured by Studco Building Systems.
5. Shelves are evenly distributed over 2/3 the wall height.
6. The tables are applicable to shelves on one side of the wall.
7. Studco takes no responsibility for the shelf design or the attachment methods unless specifically requested to carry out checks on particular systems.
8. The tables have been designed for a deflection limit of wall height/480.
9. Wall studs are clad both sides with 13mm plasterboard or thicker.
10. Noggings are provided in accordance with minimum requirements as specified for wall construction.
11. Studs are to be continuous, not spliced.

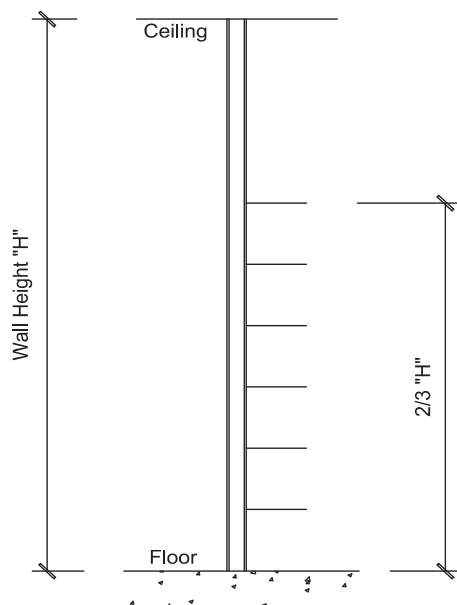


Fig. 1 Shelf Distribution Detail

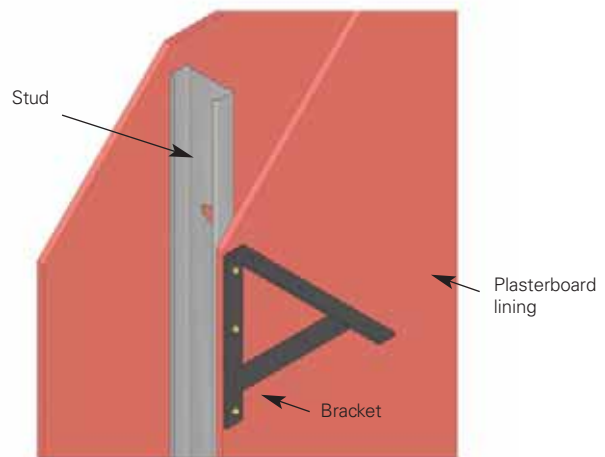


Fig. 2 Bracket Fixing to Stud Wall.

Consult Studco Engineer for project specifications.

Top Hat & Cladding Sections



Heavy Gauge Top Hats

Available in a range of sizes for fixing cladding to interior and exterior building structures.

Top Hat & Cladding Sections

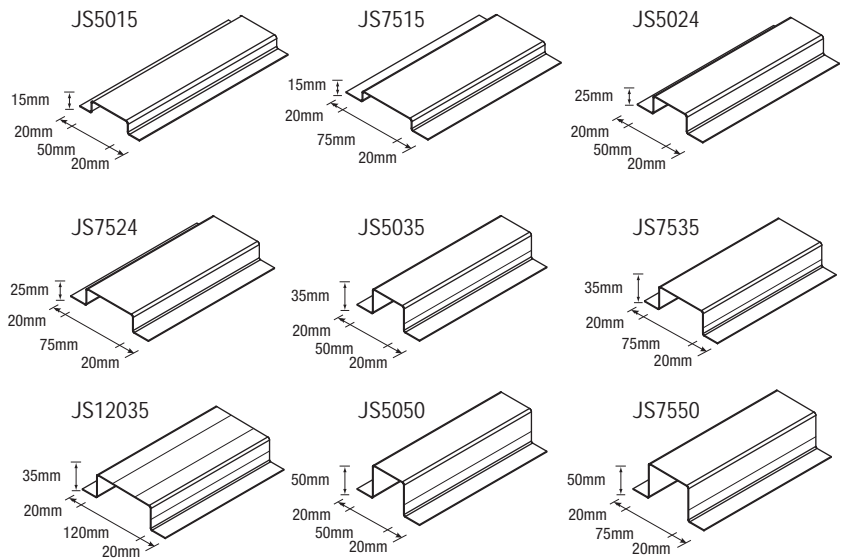
Top Hats are used for fixing support for lining material where the structural framework is not suitable for fixing directly to. A range of Junction Studs, Battens and Top Hats in various sizes and thicknesses are available to suit any cladding requirements for interior or exterior use. Refer to page 69-71 for Top Hat span tables. Top Hat sections can be custom rolled to suit your project specific requirements.

Components

Top Hats

Table 91

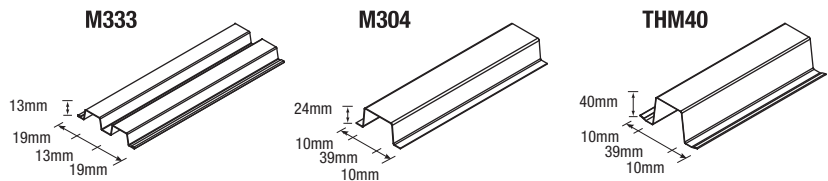
PART No	DESCRIPTION
JS5015	Top Hat 50 x 15 x 1.15BMT
JS7515	Top Hat 75 x 15 x 1.15BMT
JS5024	Top Hat 50 x 25 x 1.15BMT
JS7524	Top Hat 75 x 25 x 1.15BMT
JS5035	Top Hat 50 x 35 x 1.15BMT
JS7535	Top Hat 75 x 35 x 1.15BMT
JS12035	Top Hat 120 x 35 x 1.15BMT
JS5050	Top Hat 50 x 50 x 1.15BMT
JS7550	Top Hat 75 x 50 x 1.15BMT



Battens

Table 92

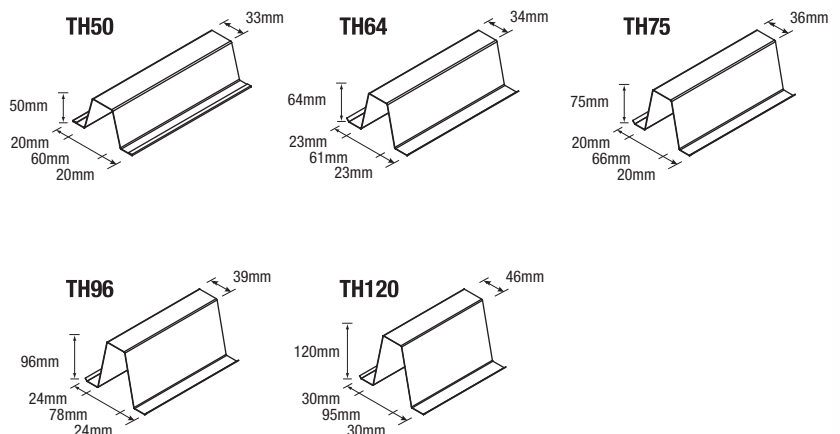
PART No	DESCRIPTION
M333S	Recessed Batten 13mm Smooth Face
M304	Batten 24mm x 0.75BMT
THM40	Batten 40mm x 40mm x 0.48BMT



Top Hat - Angled legs

Table 93

PART No	DESCRIPTION
TH5075	Top Hat 50mm x 0.75BMT
TH6475	Top Hat 64mm x 0.75BMT
TH6495	Top Hat 64mm x 0.95BMT
TH7575	Top Hat 75mm x 0.75BMT
TH7595	Top Hat 75mm x 0.95BMT
TH9675	Top Hat 96mm x 0.75BMT
TH9695	Top Hat 96mm x 0.95BMT
TH12075	Top Hat 120mm x 0.75BMT
TH12095	Top Hat 120mm x 0.95BMT



Top Hat & Cladding Sections

Installation Guide - Top Hats and Junction Studs

Top Hat & Cladding Sections

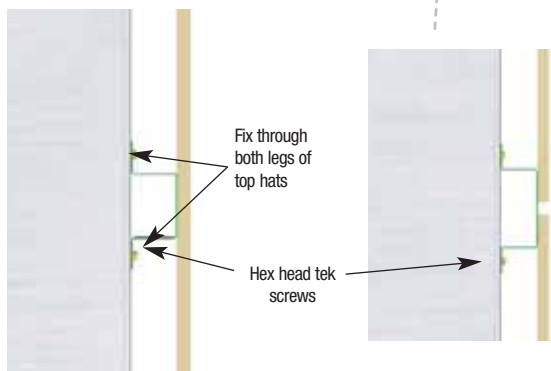
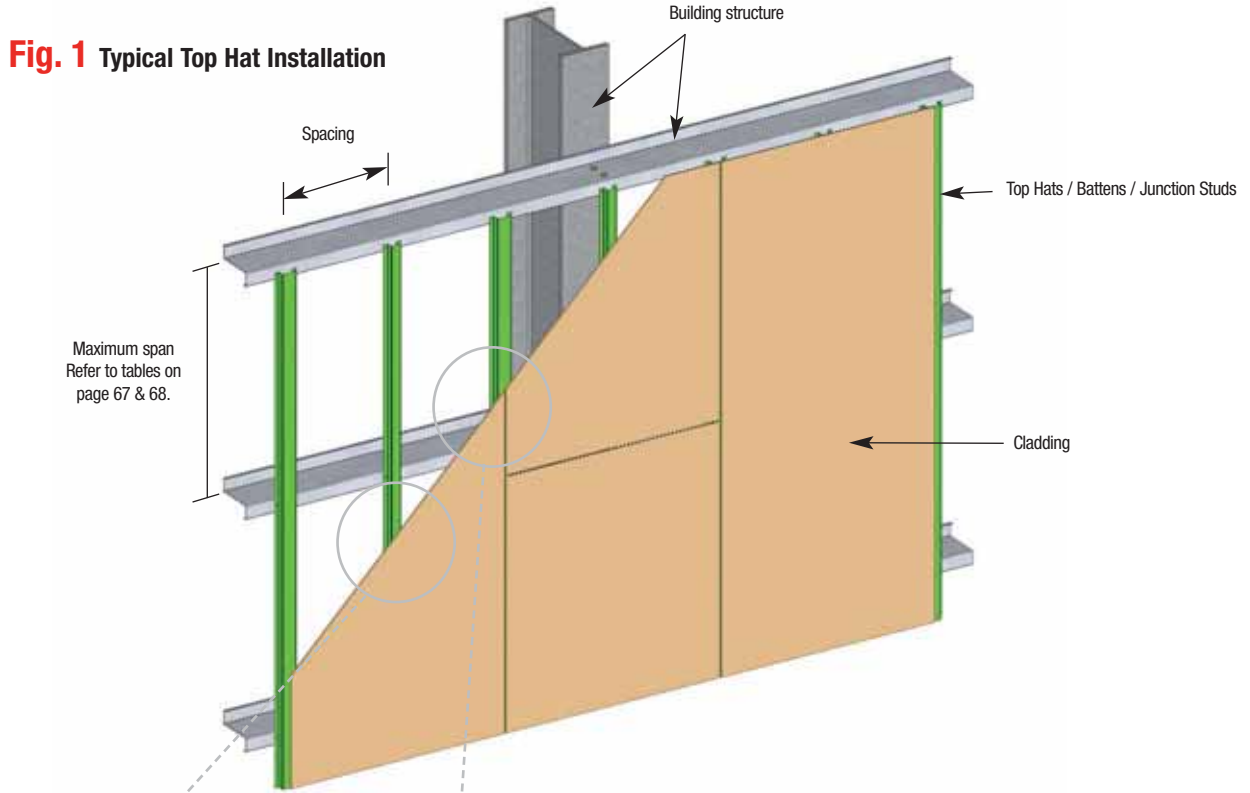


Fig. 2 Top Hat Sections to Support CFC Sheeting

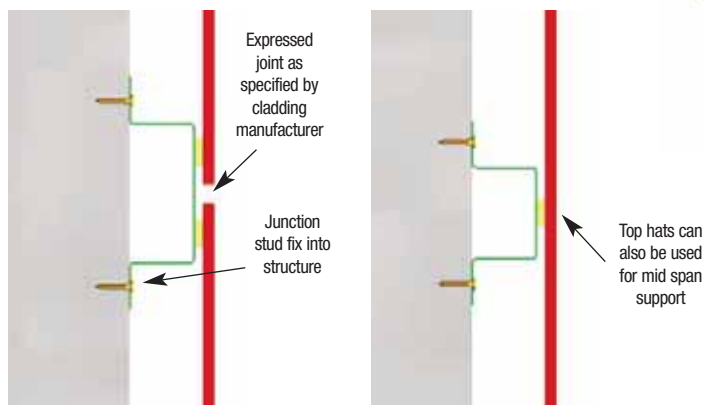


Fig. 3 Top Hat Sections to Support Aluminium Composite Panel

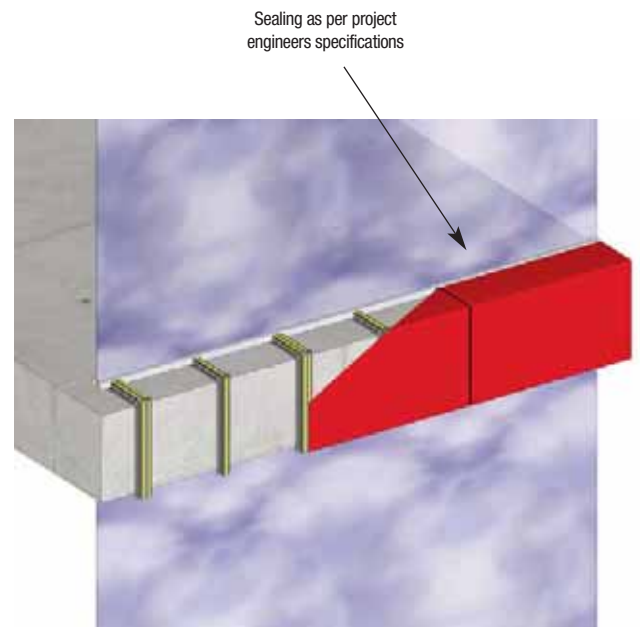


Fig. 4 Junction stud fixed to primary structure to support composite panel

Span Tables - Top Hats

Design Notes:

1. Cladding deflection limit = Span / 360
2. Seismic was not specified or considered in this design.
3. Framing design complies with AS/NZ1170 (Part 0, 1, 2)
4. Cladding weight = 30 kg/m² Max
5. G2 Steel, Fy = 300MPa and Fu = 350MPa

Table 94

JS5050115 (SPAN/360)							
Design Wind Pressure kPa		Single Span		Double Span		Three Spans	
		Top Hat Spacing mm		Top Hat Spacing mm		Top Hat Spacing mm	
		450	600	450	600	450	600
SER	ULT	MAXIMUM SPAN OF TOP HAT PROFILE (mm)					
0.53	0.75	2450	2200	3200	2950	3000	2750
0.7	1.0	2200	2000	2900	2700	2700	2500
1.05	1.5	1900	1750	2600	2350	2400	2100
1.4	2.0	1750	1600	2300	2050	2150	1950
1.75	2.5	1600	1450	2100	1900	2000	1800
2.1	3.0	1500	1400	1950	1750	1900	1700
2.8	4.0	1400	1250	1750	1550	1700	1550

Table 95

JS12035115 (SPAN/360)							
Design Wind Pressure kPa		Single Span		Double Span		Three Spans	
		Top Hat Spacing mm		Top Hat Spacing mm		Top Hat Spacing mm	
		450	600	450	600	450	600
SER	ULT	MAXIMUM SPAN OF TOP HAT PROFILE (mm)					
0.53	0.75	2050	1800	2700	2500	2500	2300
0.7	1.0	1850	1700	2500	2250	2300	2100
1.05	1.5	1600	1450	2200	2000	2000	1800
1.4	2.0	1450	1350	2000	1800	1800	1650
1.75	2.5	1350	1250	1850	1650	1700	1550
2.1	3.0	1300	1150	1700	1550	1600	1450
2.8	4.0	1150	1050	1550	1400	1450	1300

Table 96

JS5015115 (SPAN/360)							
Design Wind Pressure kPa		Single Span		Double Span		Three Spans	
		Top Hat Spacing mm		Top Hat Spacing mm		Top Hat Spacing mm	
		450	600	450	600	450	600
SER	ULT	MAXIMUM SPAN OF TOP HAT PROFILE (mm)					
0.53	0.75	950	850	1300	1150	NA	
0.7	1.0	850	800	1150	1050		
1.05	1.5	750	700	1000	900		
1.4	2.0	700	630	900	850		
1.75	2.5	650	600	850	800		
2.1	3.0	600	550	800	750		
2.8	4.0	550	500	750	650		

Table 97

JS5025115 (SPAN/360)							
Design Wind Pressure kPa		Single Span		Double Span		Three Spans	
		Top Hat Spacing mm		Top Hat Spacing mm		Top Hat Spacing mm	
		450	600	450	600	450	600
SER	ULT	MAXIMUM SPAN OF TOP HAT PROFILE (mm)					
0.53	0.75	1400	1250	1900	1750	NA	
0.7	1.0	1250	1150	1750	1600		
1.05	1.5	1100	1000	1500	1400		
1.4	2.0	1000	900	1400	1250		
1.75	2.5	950	850	1300	1150		
2.1	3.0	900	800	1200	1100		
2.8	4.0	800	700	1100	1000		

Table 98

JS5035115 (SPAN/360)							
Design Wind Pressure kPa		Single Span		Double Span		Three Spans	
		Top Hat Spacing mm		Top Hat Spacing mm		Top Hat Spacing mm	
		450	600	450	600	450	600
SER	ULT	MAXIMUM SPAN OF TOP HAT PROFILE (mm)					
0.53	0.75	1850	1650	2300	2100	NA	
0.7	1.0	1650	1500	2150	1950		
1.05	1.5	1450	1300	1900	1750		
1.4	2.0	1300	1200	1750	1600		
1.75	2.5	1200	1100	1600	1450		
2.1	3.0	1100	1000	1500	1400		
2.8	4.0	1050	950	1400	1200		

Notes:

1. Ultimate limit state load capacity to be calculated in accordance with AS/NZS 1170.0 as applicable
2. Connections to be independently checked

Span Tables - Junction Studs

Design Notes:

1. Cladding deflection limit = Span / 240
2. Seismic was not specified or considered in this design.
3. Framing design complies with AS/NZ1170 (Part 0, 1, 2)
4. Cladding weight = 30 kg/m² Max
5. G2 Steel, Fy = 300MPa and Fu = 350MPa

Table 99

JS5050115 (SPAN/240)							
Design Wind Pressure kPa		Single Span		Double Span		Three Spans	
		Top Hat Spacing mm		Top Hat Spacing mm		Top Hat Spacing mm	
		450	600	450	600	450	600
SER	ULT	MAXIMUM SPAN OF TOP HAT PROFILE (mm)					
0.53	0.75	280.0	2550	3750	3300	3450	3150
0.7	1.0	255.0	2300	3300	2850	3150	2850
1.05	1.5	2200	200.0	2700	2350	2750	2450
1.4	2.0	2000	1800	2300	2050	2500	2250
1.75	2.5	1850	1700	2100	1900	2300	2050
2.1	3.0	1750	1500	1950	1750	2150	1900
2.8	4.0	1600	1450	1750	1550	1900	1650

Table 100

JS12035115 (SPAN/240)							
Design Wind Pressure kPa		Single Span		Double Span		Three Spans	
		Top Hat Spacing mm		Top Hat Spacing mm		Top Hat Spacing mm	
		450	600	450	600	450	600
SER	ULT	MAXIMUM SPAN OF TOP HAT PROFILE (mm)					
0.53	0.75	2350	2100	3150	2850	2900	2650
0.7	1.0	2150	1950	2850	2550	2650	2400
1.05	1.5	1850	1700	2500	2250	2300	2100
1.4	2.0	1700	1550	2250	1950	2100	1900
1.75	2.5	1550	1400	2000	1650	1950	1750
2.1	3.0	1450	1350	1800	1550	1800	1650
2.8	4.0	1350	1100	1550	1350	1650	1500

Table 101

JS5015115 (SPAN/240)							
Design Wind Pressure kPa		Single Span		Double Span		Three Spans	
		Top Hat Spacing mm		Top Hat Spacing mm		Top Hat Spacing mm	
		450	600	450	600	450	600
SER	ULT	MAXIMUM SPAN OF TOP HAT PROFILE (mm)					
0.53	0.75	1100	1000	1500	1350	NA	
0.7	1.0	1000	900	1350	1200		
1.05	1.5	850	800	1200	1050		
1.4	2.0	800	700	1050	950		
1.75	2.5	750	680	1000	900		
2.1	3.0	700	640	950	800		
2.8	4.0	640	580	800	700		

Table 102

JS5025115 (SPAN/240)							
Design Wind Pressure kPa		Single Span		Double Span		Three Spans	
		Top Hat Spacing mm		Top Hat Spacing mm		Top Hat Spacing mm	
		450	600	450	600	450	600
SER	ULT	MAXIMUM SPAN OF TOP HAT PROFILE (mm)					
0.53	0.75	1650	1500	2200	2000	NA	
0.7	1.0	1500	1350	2000	1800		
1.05	1.5	1300	1150	1750	1600		
1.4	2.0	1150	1050	1600	1450		
1.75	2.5	1110	1000	1450	1350		
2.1	3.0	1000	950	1400	1250		
2.8	4.0	950	850	1250	1100		

Table 103

JS5035115 (SPAN/240)							
Design Wind Pressure kPa		Single Span		Double Span		Three Spans	
		Top Hat Spacing mm		Top Hat Spacing mm		Top Hat Spacing mm	
		450	600	450	600	450	600
SER	ULT	MAXIMUM SPAN OF TOP HAT PROFILE (mm)					
0.53	0.75	2100	1900	2850	2550	NA	
0.7	1.0	1900	1750	2600	2350		
1.05	1.5	1650	1500	2250	2050		
1.4	2.0	1500	1400	2050	1850		
1.75	2.5	1400	1300	1900	1700		
2.1	3.0	1300	1200	1800	1600		
2.8	4.0	1200	1050	1600	1450		

Span Tables - Top Hats

Table 104

TOP HAT SECTION TH50 X 0.75BMT													
		PURLIN SPACING											
Loading	Wind Class	600			900			1200			1500		
		Single	Double	Lapped	Single	Double	Lapped	Single	Double	Lapped	Single	Double	Lapped
MAXIMUM ALLOWABLE SPAN (mm)													
INWARD LOADS		1600	2439	2661	1578	2389	2603	1556	2344	2551	1537	2303	2477
OUTWARD LOADS	TC3	2777	3715	3959	2426	3246	3458	2204	2949	3142	2046	2737	2917
	TC2.5	2691	3600	3837	2351	3145	3352	2136	2858	3045	1983	2653	2827
	TC2.0	2611	3494	3723	2281	3052	3253	2073	2773	2955	1924	2575	2743

Table 105

TOP HAT SECTION TH64 X 0.75BMT													
		PURLIN SPACING											
Loading	Wind Class	600			900			1200			1500		
		Single	Double	Lapped	Single	Double	Lapped	Single	Double	Lapped	Single	Double	Lapped
MAXIMUM ALLOWABLE SPAN (mm)													
INWARD LOADS		2128	3229	3519	2090	3147	3424	2054	3074	3335	2022	3008	3202
OUTWARD LOADS	TC3	3380	4522	4819	2953	3951	4210	2683	3589	3825	2490	3332	3551
	TC2.5	3275	4383	4670	2861	3829	4080	2600	3479	3707	2413	3229	3441
	TC2.0	3179	4253	4532	2777	3716	3959	2523	3376	3597	2342	3134	3340

Table 106

TOP HAT SECTION TH64 X 0.95BMT													
		PURLIN SPACING											
Loading	Wind Class	600			900			1200			1500		
		Single	Double	Lapped	Single	Double	Lapped	Single	Double	Lapped	Single	Double	Lapped
MAXIMUM ALLOWABLE SPAN (mm)													
INWARD LOADS		2384	3610	3932	2337	3510	3816	2293	3422	3714	2254	3343	3624
OUTWARD LOADS	TC3	3657	4893	5214	3195	4275	4555	2903	3884	4138	2694	3605	3842
	TC2.5	3544	4742	5053	3096	4143	4414	2813	3764	4011	2611	3494	3723
	TC2.0	3439	4602	4904	3005	4020	4284	2730	3653	3892	2534	3391	3613

Notes:

- Definition of Wind Class as per AS 1170.2
- The maximum spans stated in all cases are based on either strength or serviceability requirements for the following load cases

Serviceability Load Cases	Strength
1. Dead Load Only	G
2. Live Load Only	0.7Q
4. Wind Load	W _s
	Dead Load + Live Load
	Dead Load + Wind Load
- Deflection Limits - Span/150

Top Hat & Gladding Sections

Span Tables - Top Hats

Top Hat & Cladding Sections

Table 106

TOP HAT SECTION TH75 X 0.75BMT													
		PURLIN SPACING											
Loading	Wind Class	600			900			1200			1500		
		Single	Double	Lapped	Single	Double	Lapped	Single	Double	Lapped	Single	Double	Lapped
		MAXIMUM ALLOWABLE SPAN (mm)											
INWARD LOADS		2649	4003	4358	2591	3883	4217	2539	3778	4005	2492	3686	3824
OUTWARD LOADS	TC3	3936	5266	5611	3438	4600	4902	3124	4180	4454	2900	3880	4135
	TC2.5	3814	5103	5438	3332	4458	4751	3027	4051	4316	2810	3760	4007
	TC2.0	3701	4953	5277	3233	4327	4610	2938	3931	4189	2727	3649	3889

Table 107

TOP HAT SECTION TH75 X 0.95BMT													
		PURLIN SPACING											
Loading	Wind Class	600			900			1200			1500		
		Single	Double	Lapped	Single	Double	Lapped	Single	Double	Lapped	Single	Double	Lapped
		MAXIMUM ALLOWABLE SPAN (mm)											
INWARD LOADS		2964	4469	4864	2894	4324	4695	2831	4198	4551	2774	4088	4426
OUTWARD LOADS	TC3	4258	5698	6071	3720	4977	5304	3380	4522	4819	3138	4198	4474
	TC2.5	4127	5522	5884	3605	4824	5140	3275	4383	4670	3041	4068	4335
	TC2.0	4005	5359	5710	3499	4681	4988	3179	4253	4532	2951	3948	4207

Table 108

TOP HAT SECTION TH96 X 0.75BMT													
		PURLIN SPACING											
Loading	Wind Class	600			900			1200			1500		
		Single	Double	Lapped	Single	Double	Lapped	Single	Double	Lapped	Single	Double	Lapped
		MAXIMUM ALLOWABLE SPAN (mm)											
INWARD LOADS		3521	5289	5750	3426	5095	5527	3341	4930	5233	3266	4787	4960
OUTWARD LOADS	TC3	4808	6433	6855	4200	5620	5988	3816	5106	5441	3542	4740	5051
	TC2.5	4659	6234	6643	4070	5446	5803	3698	4948	5273	3433	4594	4895
	TC2.0	4522	6050	6447	3950	5285	5632	3589	4802	5117	3332	4421	4750

Notes:

- Definition of Wind Class as per AS 1170.2
- The maximum spans stated in all cases are based on either strength or serviceability requirements for the following load cases

Serviceability Load Cases	Strength	
1. Dead Load Only	G	Dead Load + Live Load 1.2 G + 1.5Q
2. Live Load Only	0.7Q	Dead Load + Wind Load 0.9 G + Wu
4. Wind Load	Ws	
- Deflection Limits - Span/150

Span Tables - Top Hats

Top Hat & Gladding Sections

Table 109

TOP HAT SECTION TH96 X 0.95BMT													
		PURLIN SPACING											
Loading	Wind Class	600			900			1200			1500		
		Single	Double	Lapped	Single	Double	Lapped	Single	Double	Lapped	Single	Double	Lapped
MAXIMUM ALLOWABLE SPAN (mm)													
INWARD LOADS		3935	5894	6404	3818	5661	6136	3716	5465	5914	3626	5297	5724
OUTWARD LOADS	TC3	5202	6960	7417	4544	6080	6479	4129	5525	5887	3833	5129	5465
	TC2.5	5041	6745	7188	4404	5893	6279	4001	5354	5705	3714	4970	5296
	TC2.0	4892	6546	6976	4274	5719	6094	3883	5196	5537	3605	4823	5140

Table 110

TOP HAT SECTION TH120 X 0.75BMT													
		PURLIN SPACING											
Loading	Wind Class	600			900			1200			1500		
		Single	Double	Lapped	Single	Double	Lapped	Single	Double	Lapped	Single	Double	Lapped
MAXIMUM ALLOWABLE SPAN (mm)													
INWARD LOADS		4997	7438	8070	4821	7096	7679	4670	6816	7363	4539	6580	7098
OUTWARD LOADS	TC3	6174	8261	8803	5394	7217	7690	4900	6557	6987	4549	6087	6486
	TC2.5	5983	8006	8531	5227	6994	7453	4749	6354	6771	4409	5899	6286
	TC2.0	5807	7770	8279	5073	6787	7233	4609	6167	6571	4279	5725	6100

Table 111

TOP HAT SECTION TH120 X 0.95BMT													
		PURLIN SPACING											
Loading	Wind Class	600			900			1200			1500		
		Single	Double	Lapped	Single	Double	Lapped	Single	Double	Lapped	Single	Double	Lapped
MAXIMUM ALLOWABLE SPAN (mm)													
INWARD LOADS		5571	8266	8962	5359	7860	8500	5180	7532	8131	5026	7258	7824
OUTWARD LOADS	TC3	6680	8938	9525	5836	7808	8321	5302	7095	7560	4922	6586	7018
	TC2.5	6474	8662	9230	5655	7567	8064	5138	6875	7326	4770	6383	6801
	TC2.0	6283	8407	8958	5488	7344	7826	4987	6672	7110	4629	6194	6600

Notes:

- Definition of Wind Class as per AS 1170.2
- The maximum spans stated in all cases are based on either strength or serviceability requirements for the following load cases

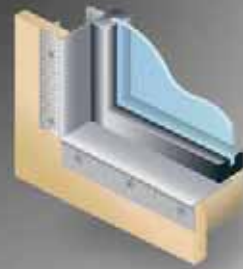
Serviceability Load Cases	Strength	
1. Dead Load Only	G	Dead Load + Live Load 1.2 G + 1.5Q
2. Live Load Only	0.7Q	Dead Load + Wind Load 0.9 G + Wu
4. Wind Load	Ws	
- Deflection Limits - Span/150

EZY Finishing Sections



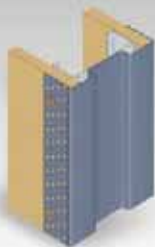
EzyPelmet

The Strong And Versatile
Alternative For Stop Ends



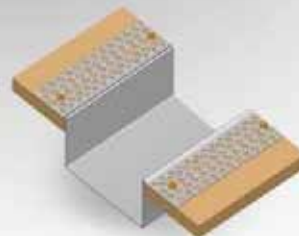
EzyReveal

Quick And Economical
Finishing Of Reveals



EzyCap

Flush Finish Cavity Slider Kit



FastCap

Custom Finishing Sections

EZY Finishing Sections

Ezy finishing sections EzyCap, Ezyreveal, Cavkit, Fastcap and Ezy Pelmet are designed to provide a quick and economical method for the finishing and capping of plasterboard. Manufactured from cold rolled form steel providing a strong and secure section, that is durable and fast to install.

Components

Table 112

PART NO	DESCRIPTION
RA-	EzyReveal Angle x 0.75BMT
EC-	EzyCap Section x 0.75BMT
CAV-	CavKit Closer Cap x 0.75BMT
FCP-	FastCap Profile Rebate x 0.75BMT
SL-	Custom Shadowline Angle x 0.75BMT

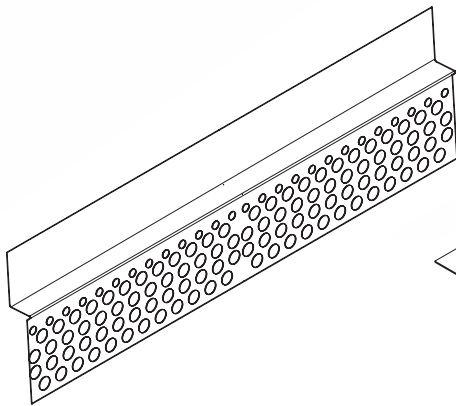
EzyReveal

EzyPelmet

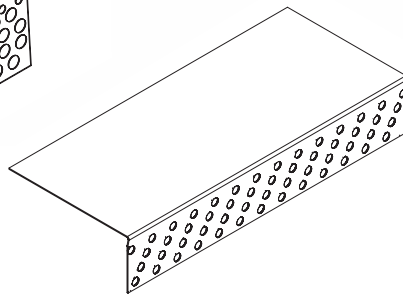
FastCap

EzyCap

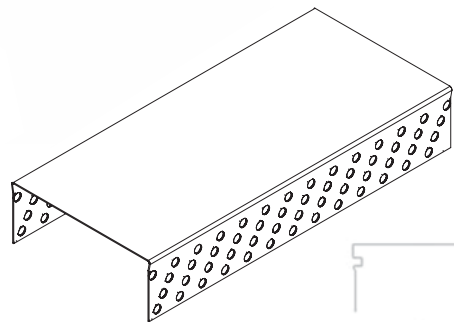
CavKit



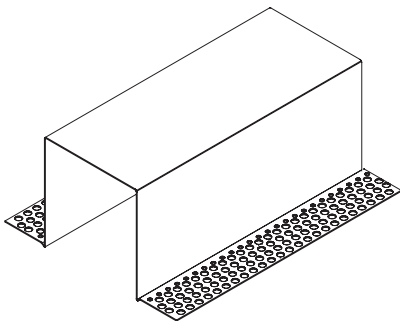
SL - Custom Shadowline Angle
Custom sizes manufactured to your project requirements.



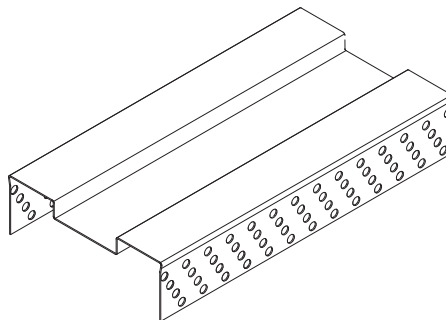
RA - EzyReveal
Quick and economical finishing of reveals.



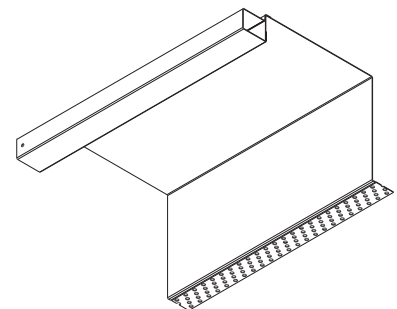
EC - EzyCap
The strong and versatile alternative to stop ends.



FCP - FastCap
Custom finishing sections.



CAV - Cavkit Closer Cap
Flush finish cavity slide closer cap.



EzyPelmet
Flush finish pelmet section

EzyReveal Installation Guide

EzyReveal is designed for quick and economical finishing of window reveals. Manufactured from cold rolled steel providing a strong and secure reveal eliminating warping, twisting, cracking and damage from UV rays. EzyReveal can be used with PVC finish trim to create custom size reveals. EzyReveal can be used as window trim, reveal, finishing rebates in plasterboard.

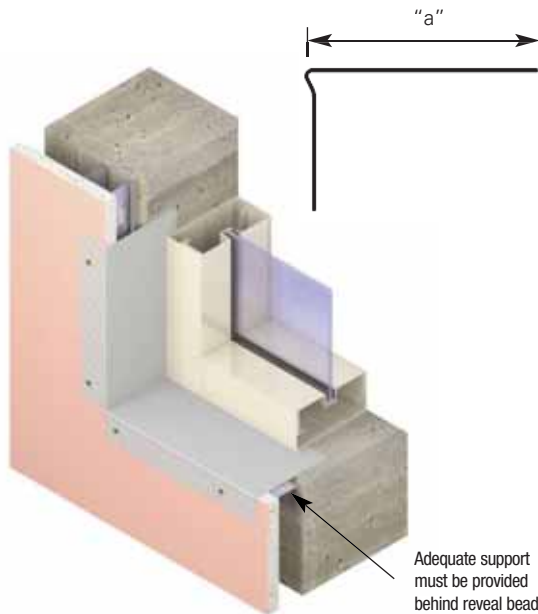


Table 113

EZYREVEAL		
Section Width "a"	Description	Part No.s
20mm	EZY-REVEAL 20mm REVEAL ANGLE X 0.75BMT	RA20
25mm	EZY-REVEAL 25mm REVEAL ANGLE X 0.75BMT	RA25
30mm	EZY-REVEAL 30mm REVEAL ANGLE X 0.75BMT	RA30
35mm	EZY-REVEAL 35mm REVEAL ANGLE X 0.75BMT	RA35
40mm	EZY-REVEAL 40mm REVEAL ANGLE X 0.75BMT	RA35
45mm	EZY-REVEAL 45mm REVEAL ANGLE X 0.75BMT	RA45
50mm	EZY-REVEAL 50mm REVEAL ANGLE X 0.75BMT	RA50
60mm	EZY-REVEAL 60mm REVEAL ANGLE X 0.75BMT	RA60
65mm	EZY-REVEAL 65mm REVEAL ANGLE X 0.75BMT	RA65
75mm	EZY-REVEAL 75mm REVEAL ANGLE X 0.75BMT	RA75
80mm	EZY-REVEAL 80mm REVEAL ANGLE X 0.75BMT	RA80
90mm	EZY-REVEAL 90mm REVEAL ANGLE X 0.75BMT	RA90
100mm	EZY-REVEAL 100mm REVEAL ANGLE X 0.75BMT	RA100
110mm	EZY-REVEAL 110mm REVEAL ANGLE X 0.75BMT	RA110
120mm	EZY-REVEAL 120mm REVEAL ANGLE X 0.75BMT	RA120
135mm	EZY-REVEAL 135mm REVEAL ANGLE X 0.75BMT	RA135
150mm	EZY-REVEAL 150mm REVEAL ANGLE X 0.75BMT	RA150

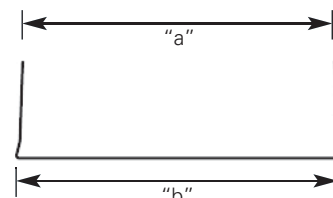
EzyCap Installation Guide

EzyCap is the strong and versatile alternative for stop ends. Manufactured from cold rolled steel providing a strong and secure wall end cap that is both durable and fast to install. Hard to reach wall ends are made possible with EzyCap. EzyCap can be used for the capping of internal balustrades, window openings and internal partition wall ends. EzyCap is available in a range of sizes to suit various wall configurations.



Table 114

EZYCAP			
Section Width "a"	Section Width "b"	Configuration Stud and Plaster	Part No.s
79mm	84mm	51 stud + 13 + 13	EC79
86mm	91mm	64 stud + 10 + 10	EC86
92mm	97mm	64 stud + 13 + 13	EC92
98mm	103mm	76 stud + 10 + 10	EC98
104mm	107mm	76 stud + 13 + 13	EC104
111mm	116mm	92 stud + 10 + 10	EC112
120mm	125mm	92 stud + 13 + 13	EC118
127mm	132mm	92 stud + 16 + 16	EC127



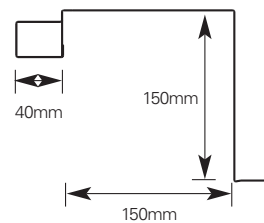
EzyPelmet

The newest addition to the EZY family of flush-finish products adds a completely new dimension to the internal perimeter of square-set interiors. Window blinds disappear, feature lighting is cleverly concealed and vast panoramas open up before your eyes with the all new EzyPelmet® from Studco.

EzyPelmet® is a two piece, pre-finished cold-rolled steel section which provides a fast, economical and prestigious solution for creating recessed window pelmets in plasterboard ceilings. It provides a simple and discrete transition between the interior ceiling and external windows, curtain wall facades or the building structure.

- Contemporary, clearview design
- Flush-finish edge for square-set interiors
- Completely concealed fixings
- Does not require fixing from the top
- Finished in white, no need to paint
- Install from below after ceiling
- Fastest method for creating window pelmets
- Suitable for blinds, curtain, lights & more

EzyPelmet® is at home in apartments, offices, hospitals, schools, houses and just about any other application where a luxurious, clearview outlook is sought.



CavKit Closer Cap

Custom Cavkit can be used to transform standard cavity sliders into architrave free, flush finish cavity sliders. The Standard Cavkit is made up of the EzyReveal and EzyCap to trim and cap the plaster edges around the door penetration. Custom made closer caps can be produced to suit any specification, see Fig 1.

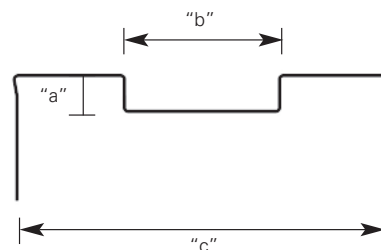
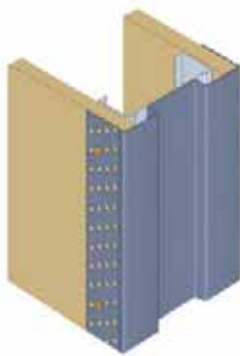


Fig. 1 Custom Cavkit Closer Cap - Specify the 'a', 'b' and 'c' dimensions to suit project requirements

Custom Finishing Sections

Custom finishing and capping of plasterboard is made easy with the FastCaps range of custom made finishing sections. FastCaps custom profiles make the finishing of difficult plasterboard profiles, rebates and large oversized rebates a dream.

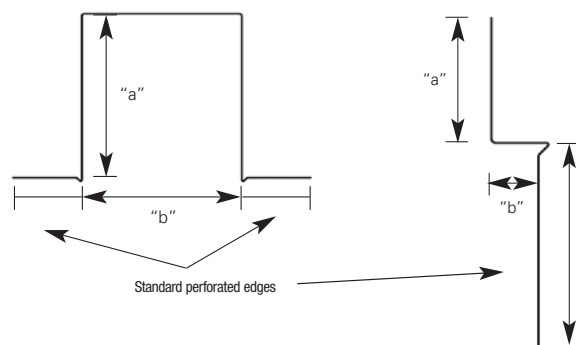
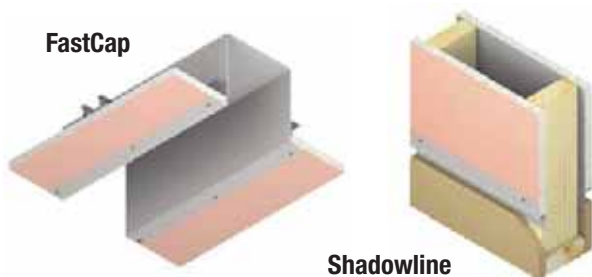


Fig. 2 FastCap - specify the 'a' and 'b' dimension to suit project requirements.

Fig. 3 Custom Shadowline - specify the 'a' and 'b' dimension to suit project requirements

NOTES:

A large rectangular grid of graph paper, consisting of 20 columns and 30 rows of small squares, intended for taking notes.

Contact the team for pricing & samples

hello@mbsarchitectural.com.au | 03 9580 7800



MBS
Architectural

Every material. One source.

Reach out to our team for support, samples and advice.

03 9580 7800

hello@mbsarchitectural.com.au

VIC | 7 Haymer Court, Braeside 3195

QLD | 13 Pease Court, Bethania 4205

@MBSarchitectural