



Apollo

ALUMINIUM BATTEN CEILING

The Apollo Aluminium Batten Ceiling comprises of innovative design and traditional construction methodology to bring you high quality, versatile and Australian made linear ceilings.



SYSTEM ATTRIBUTES

- Fast and concise installation
- Flexible design
- Various batten sizes & shapes
- Concealed click-in support clip
- Australian design & manufacture
- Group 1 Fire Performance

SECTORS

- Commercial
- Fit-Out
- Education
- Infrastructure
- Retail
- Hospitality
- Medical

Apollo+

Lower-carbon aluminium. It's better.

We make a conscious choice to use locally extruded, lower carbon aluminium, so your CO2e emissions on a project can be more than halved.

All our Apollo+ Aluminium is cleaner, not because we're ticking a box, but because it's the right thing to do. And we're so committed to this, we're offering it at the same price as standard aluminium - so our (and your) footprint is lighter.

Why Choose Apollo+?

It's called Apollo+ because it's exactly that. A solution for your project, + a little more. No smoke and mirrors, just facts.

The carbon footprint of LocAl® Green is up to 50% less than the global average for primary aluminium production* (ex smelter based on Scope 1 and Scope 2 emissions).

Whilst LocAl® Super Green boasts one of the lowest carbon emissions for primary aluminium currently available and is 75% lower than the global average for primary aluminium production.



Reducing carbon emissions from your products is important because it mitigates the effects of global climate change, improves public health, boosts the global economy, and maintains biodiversity.

When we cut carbon emissions, we help ensure cleaner air, water, and food for our generation and for generations yet to come. Choosing to use LocAl® Aluminium as part of a responsible procurement strategy for your business will positively impact your organisation's environmental impact and our climate.

The environmental impact of switching to Apollo+ in *just* 4 weeks.



Our specialist projects team are here to answer all your questions, helping bring your architectural ideas to life, while doing good.

Projects



Canacord

Finish: Basalt Flat Electro

Subtleties in design can make all the difference... To both the final look and feel of a space, as well as the budget. Hot Black came to us with a concept - basalt blue aluminium battens, tightly spaced and surrounded by plasterboard margins. We had the solution.

Our Apollo aluminium battens in 50 x 25mm at 50mm centres. With oodles of battens, comes a plethora of end caps, right? Wrong.

Cue our tried and tested solution of reducing end caps, helping the installer with less precise

end cutting, and making the overall design of the ceiling both interesting and unique.

By dropping the plasterboard margin by 50mm, we were able to sail our battens over to the top, preventing any need for end caps and reducing the overall cost of the systems significantly.

Not only this, with sweeping curves on the project, it's the precise plaster margins that create these curves, rather than stop-start battens. We think it's genius, but we'll leave that up to you to decide.

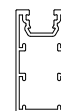

50 x 25mm





Morgan Stanley Fit-Out

Finish: Blonde Oak Timber Effect

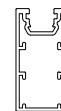

50 x 25mm

Clean and effortless lines, uncluttered spaces, and timber hues. This was the brief we were issued with by the ever-trusting team at Bates Smart. There were several timber elements across the fit-out and it was imperative the ceiling batten complimented these with similar tones.

With Group 1 fire certification being top of the agenda, real timber was out of the window thus opening the door for our Apollo Timber Effect Aluminium. Samples were sent, meticulously reviewed and our Blonde Oak finish was selected. We think the photos do the rest of the talking...

Acoustics were the next cab off the imaginary rank. As standard, the Apollo System is supplied with a 7mm integrated acoustic blanket behind the battens, providing an instant 0.55 NRC of absorption. However this didn't cut the mustard here, and a significant upgrade was required. In order to get to the magical number of 0.90 NRC, an additional 50mm acoustic blanket was hitched to the back of the ceiling. Job done.

Next came service integration and perimeter detailing.



If you've been paying attention (we hope you have) you'll know we dial up the detail when it comes to these elements - get them right and you're singing all the way to the integration bank.

We always say, 'if you don't notice it, it's done well,' and here you don't notice a thing. Linear lighting, cove detailing and level changes all seamlessly weave their magic, whilst letting the stars of the show sing.

Finally (well done for making it this far) we need to talk seismic design. With all new fit-outs within 101 Collins Street, the ceiling elements must be seismically designed and braced to meet AS1170.4.

Working with our team of certified seismic engineers, MBS was able to provide our installer with not just the design, but the materials to brace the ceiling. Tick and tick.

It's no longer good enough to just have a product that looks nice. There's a lot more that goes into great design, and we're here for it.





KPMG QLD

Finish: Dulux Duralloy White Matt

A visually striking office fit-out by the COX Brisbane team. In their quest to design an office space that resonates with drama and impact, COX Brisbane faced the challenge of striking the perfect balance between the two, without eclipsing the constraints of a budget.

Our Apollo Aluminium Batten system answered the call.

What made Apollo a game-change was its unique adaptability. The system's dynamic

ability to fine-tune batten centres became the secret sauce, allowing the COX team to artistically shape the space while adhering to budgetary parameters.

The outcome is a visually captivating design harmonising form and function, achieving a delicate equilibrium between striking aesthetics and budgetary considerations.



100 x 25mm





11 Eastern

Finish: Electro Dark Bronze

Architecture can be many things... Nuanced, brutal, elegant, classical. At 11 Eastern in South Melbourne, architects Rothelowman were looking to strike a harmonious balance between bold, unapologetic lines, and refined, sophisticated curves and palette choices. We were chosen for team bold.

Our Apollo aluminium battens needed to be substantial to hold up to the large double height entry lobby they would be situated within. It was decided a chunky 150 x 50mm batten @ 200mm centres would do the job nicely.

Next was the choice on finish - with soft whites, light stone and timber to the floors and walls, it only made sense to contrast these with a statement ceiling colour, Electro Dark Bronze.

Finally, to conceal services and provide some much-needed acoustic absorption, our Apollo 7mm black backing was applied to the rear of the ceiling. Job done.

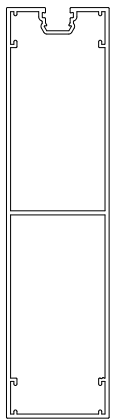

150 x 50mm



Systems

Systems

The Apollo system utilises aluminium top cross rails (TCR) with integrated batten support clips, at pre-determined centres, to fix the aluminium battens in situ. This durable and versatile system is suited to a range of construction applications.

With intricate concealed fixings, the fast installation click-on system is entirely customisable – from profiles to sizing and finishes; ensuring the product can be tailored to compliment any project design.

The Apollo batten system also provides high levels of fire and acoustic performance.

100 x 25mm Battens @ 100mm Centres

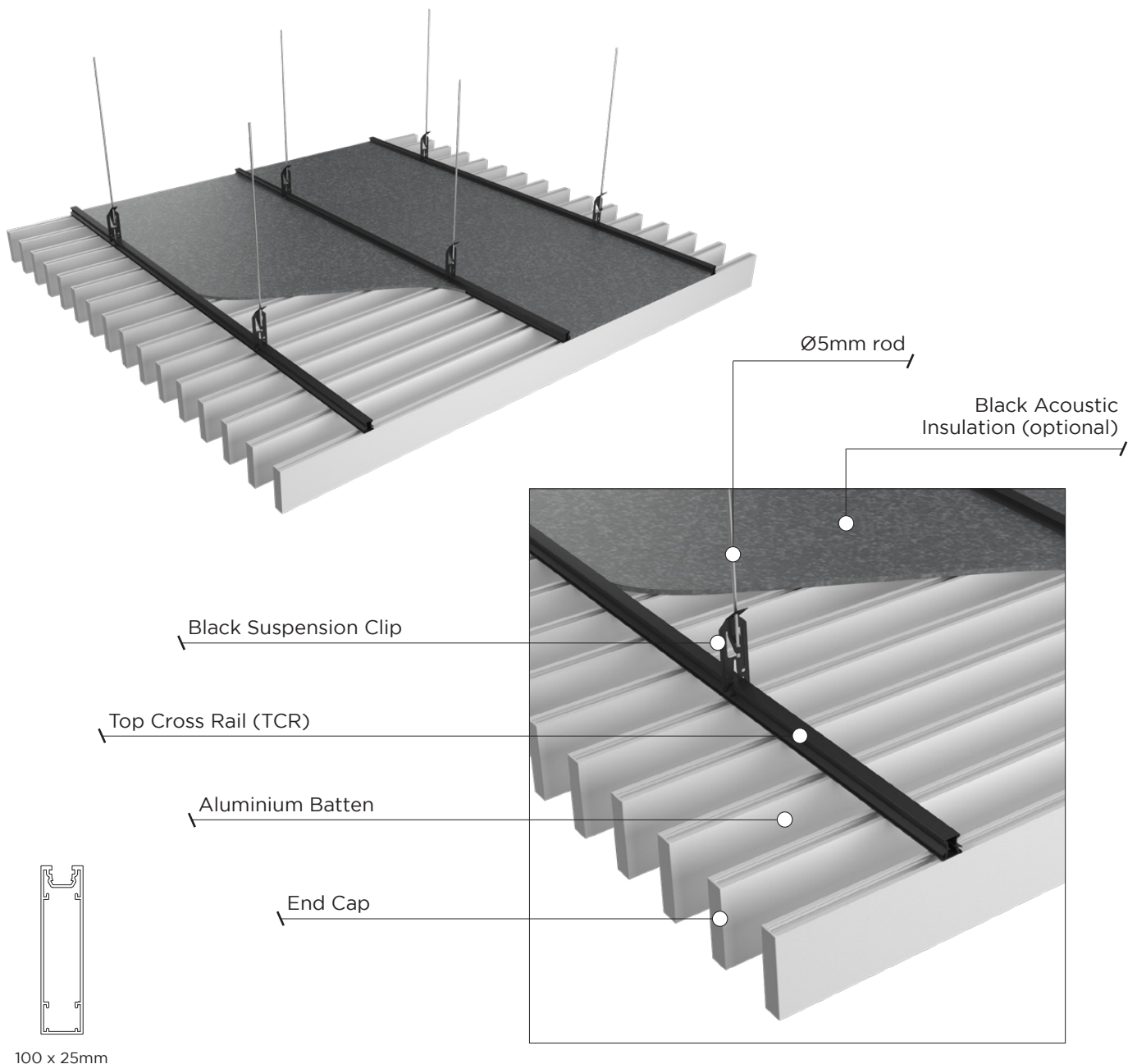

50 x 50mm Battens @ 100mm Centres

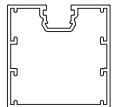
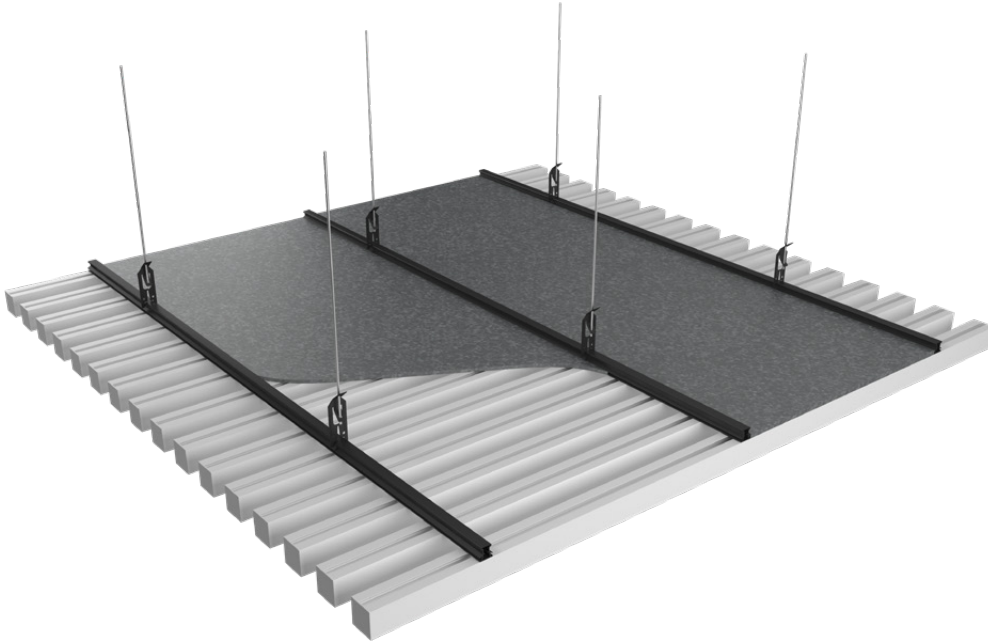

50 x 50mm

Ø50mm Battens @ 100mm Centres

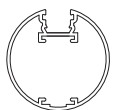
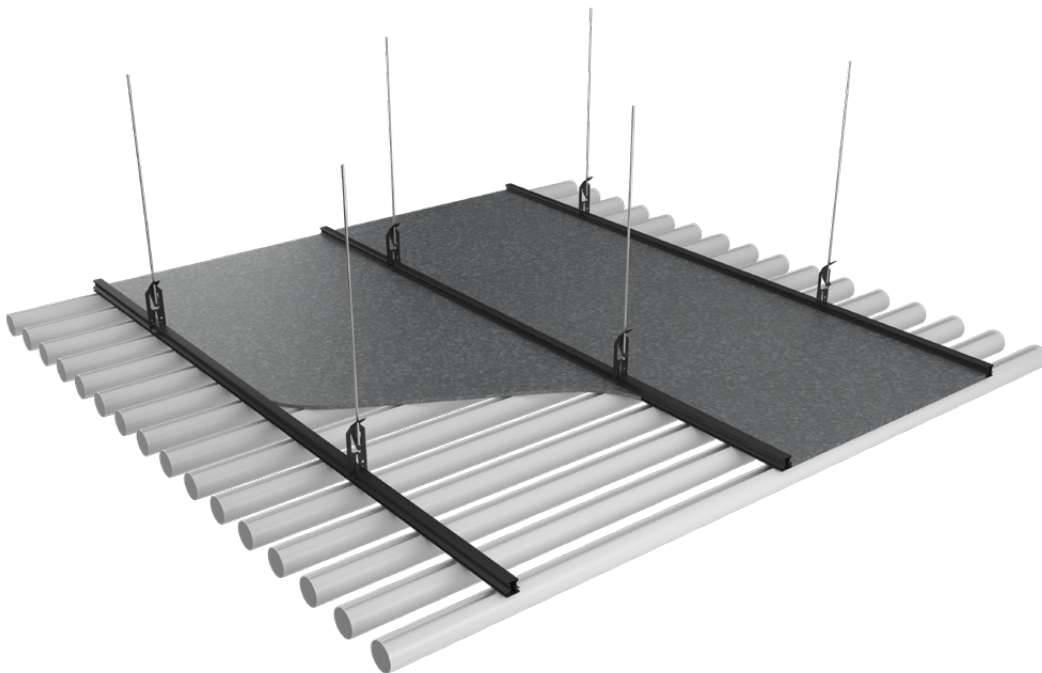

Ø50mm

25 x 90mm Battens @ 100mm Centres

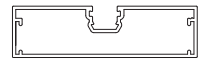
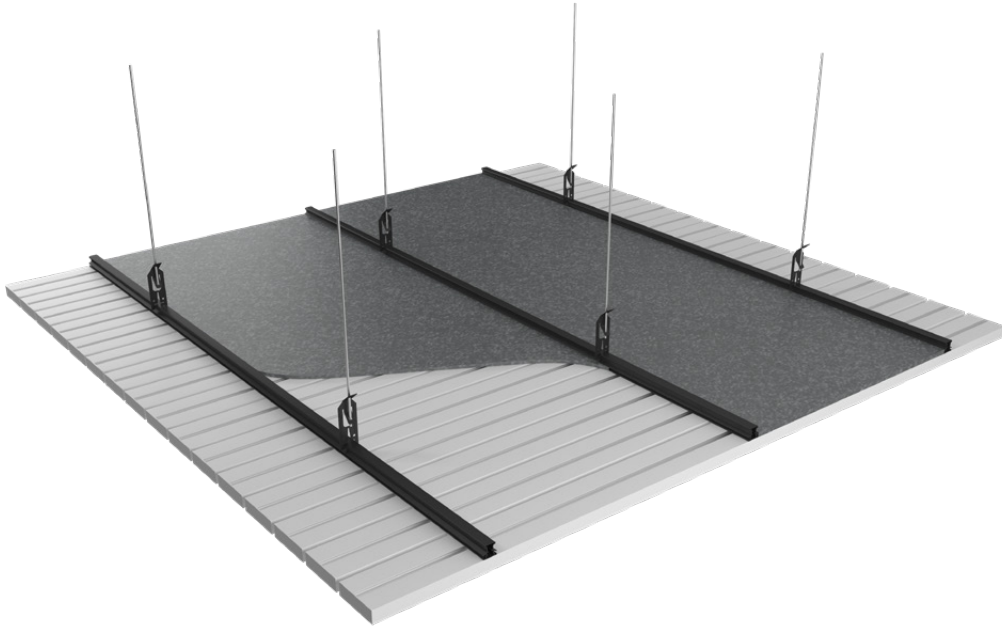

25 x 90mm

50 x 25mm Battens @ 50mm Centres

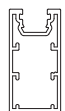
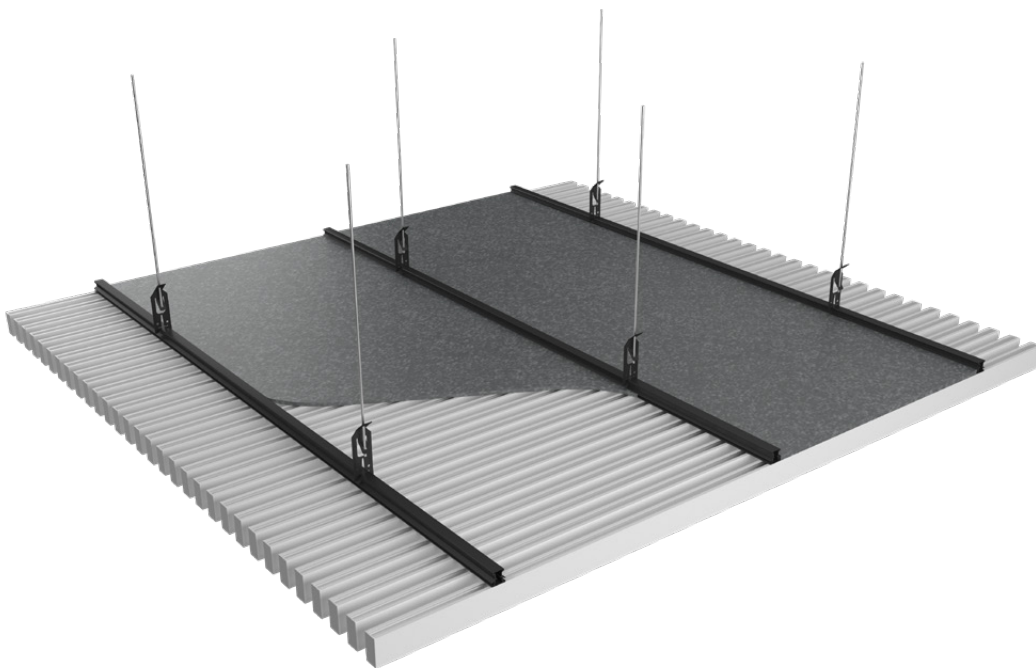

50 x 25mm

100 x 50mm Battens @ 150mm Centres

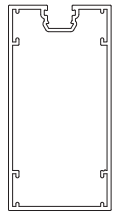
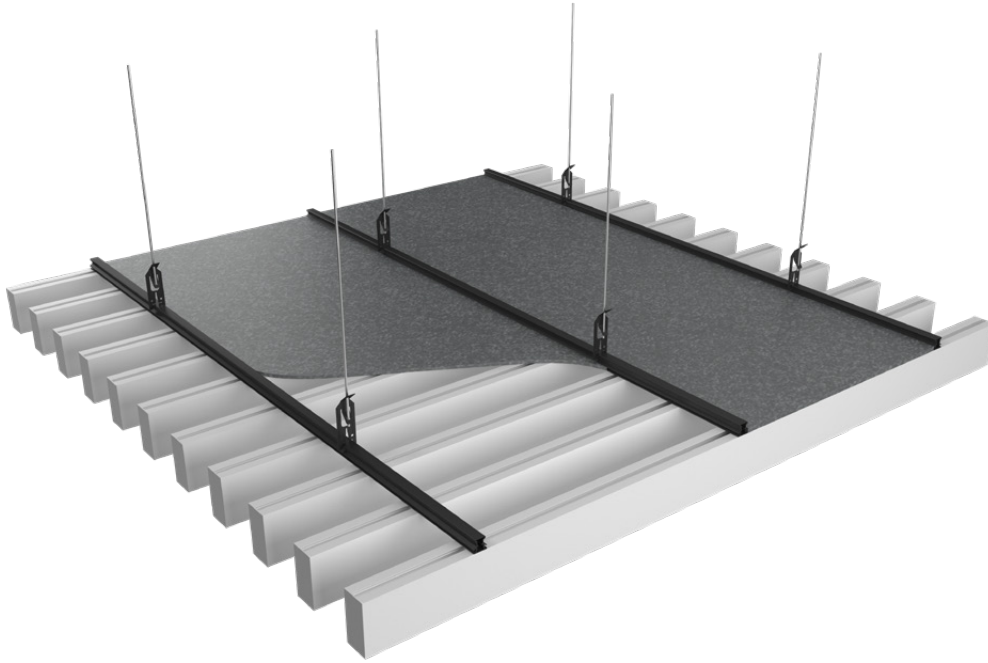

100 x 50mm

150 x 25mm Battens @ 150mm Centres

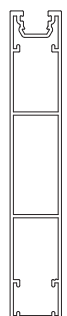
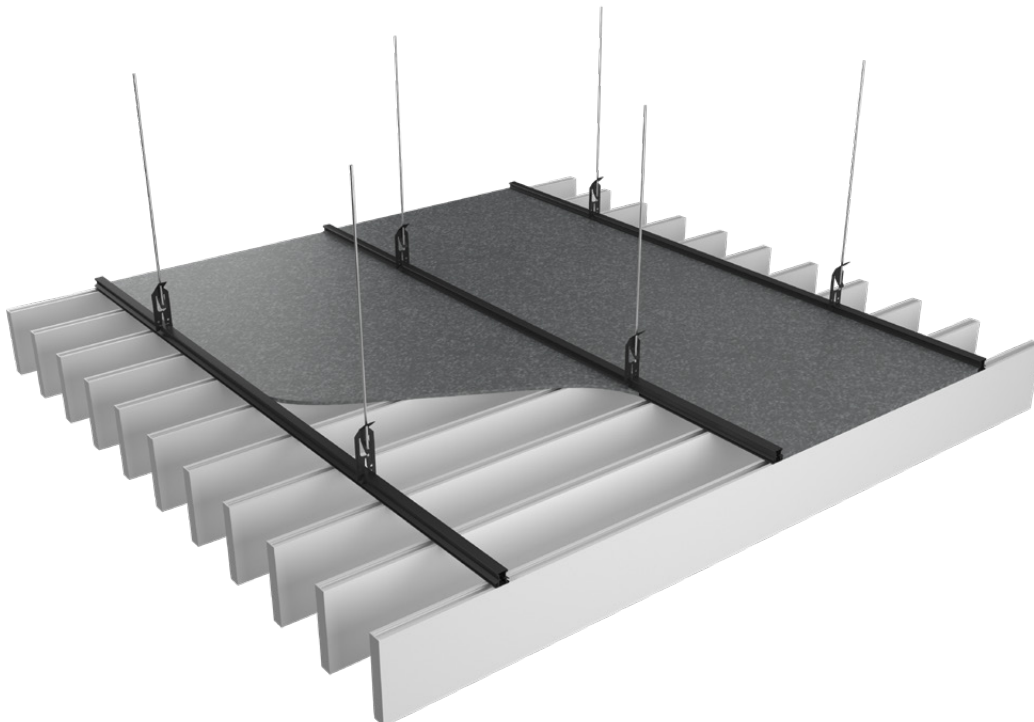

150 x 25mm

200 x 50mm Battens @ 200mm Centres

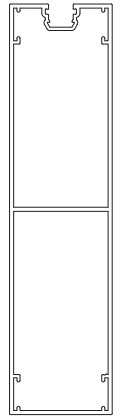
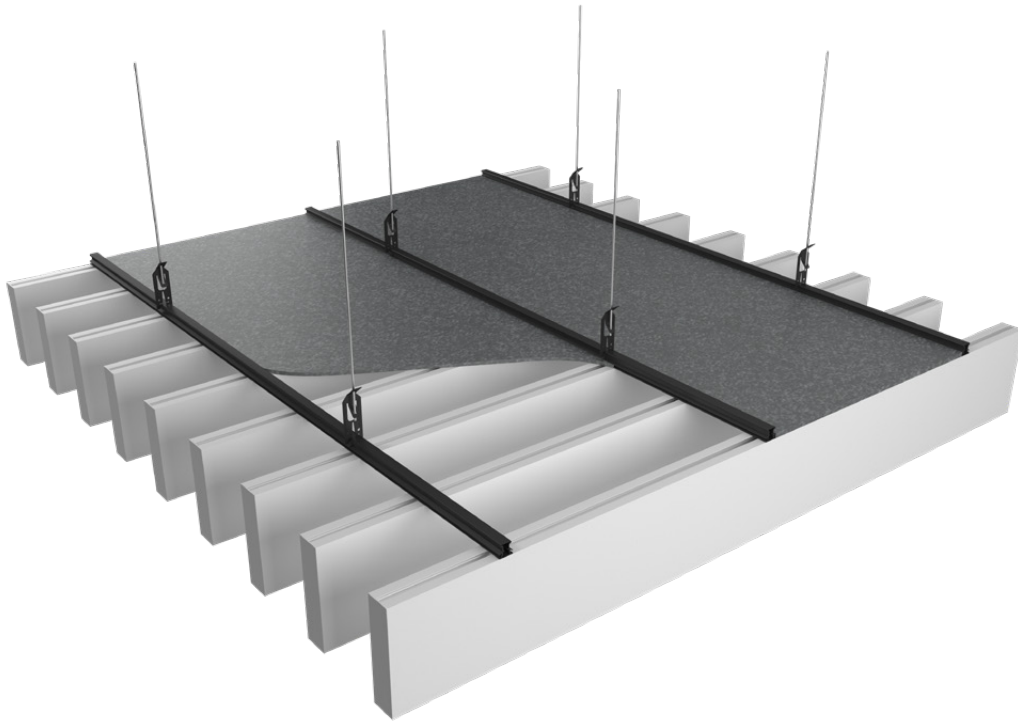

200 x 50mm



System Components

ITEM	DESCRIPTION	DIMENSION			COLOUR
		WIDTH	HEIGHT	LENGTH	
APOLLO A B 100x25 3600 WHITE	100 x 25mm Aluminium Batten	25mm	100mm	3600mm	White
APOLLO A B 50x50 3600 WHITE	50 x 50mm Aluminium Batten	50mm	50mm	3600mm	White
APOLLO A B Ø50 3600 WHITE	Ø50mm Aluminium Batten	Ø50mm	-	3600mm	White
APOLLO A B 25x90 3600 WHITE	25 x 90mm Aluminium Batten	90mm	25mm	3600mm	White
APOLLO A B 50x25 3600 WHITE	50 x 25mm Aluminium Batten	25mm	50mm	3600mm	White
APOLLO A B 100x50 3600 WHITE	100 x 50mm Aluminium Batten	50mm	100mm	3600mm	White
APOLLO A B 150x25 3600 WHITE	150 x 25mm Aluminium Batten	25mm	150mm	3600mm	White
APOLLO A B 200x50 3600 WHITE	200 x 50mm Aluminium Batten	50mm	200mm	3600mm	White
APOLLO A B JOINER 180	Aluminium Batten Straight Joiner	15.85mm	-	70mm	Mill
APOLLO A B JOINER 90	Aluminium Batten 90° Joiner	15.85mm	-	70mm	Mill
APOLLO A B 100x25 EC WHITE	Aluminium Batten 100 x 25mm End Cap	25mm	100mm	-	White
APOLLO A B 50x50 EC WHITE	Aluminium Batten 50 x 50mm End Cap	50mm	50mm	-	White
APOLLO A B Ø50 EC WHITE	Aluminium Batten Ø50mm End Cap	Ø50mm	-	-	White
APOLLO A B CLIP BLACK	Aluminium Batten Support Clip	-	-	-	Black
APOLLO A TCR 3600 BLACK	Aluminium Top Cross Rail (TCR)	26mm	25mm	3600mm	Black
APOLLO SUSPCLIP BLACK	Black Suspension Clip	-	-	-	Black
5.00G3600	Ø5mm Galvanised Rod	Ø5mm	-	3000mm	Mill

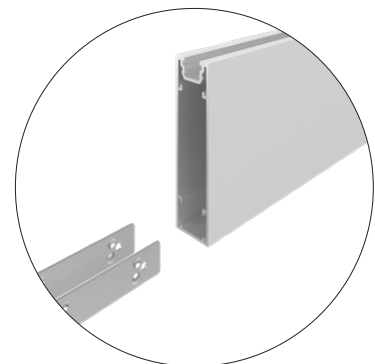
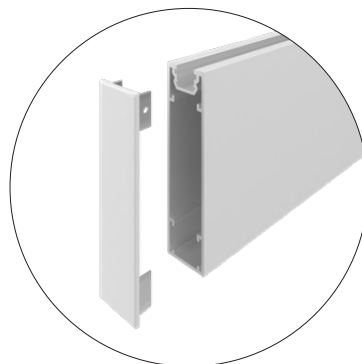

Typical System Section

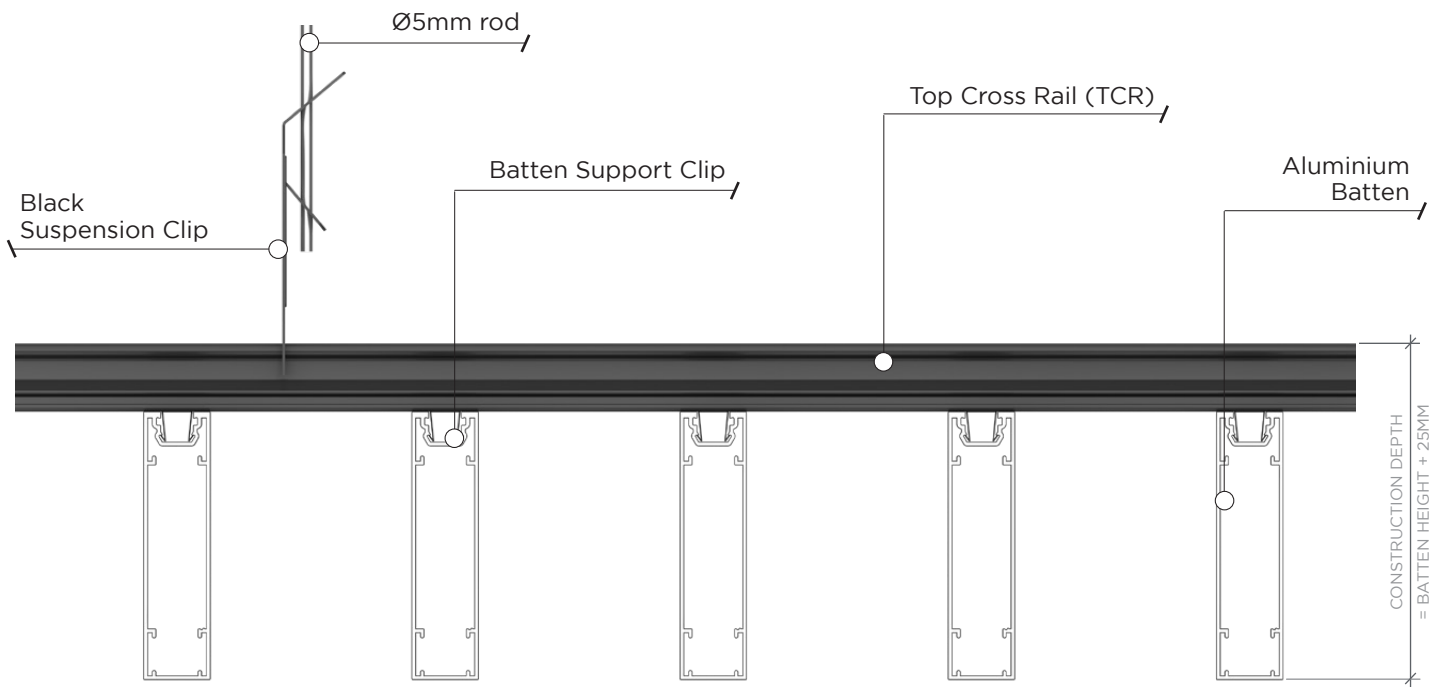

Standard Batten Sizes

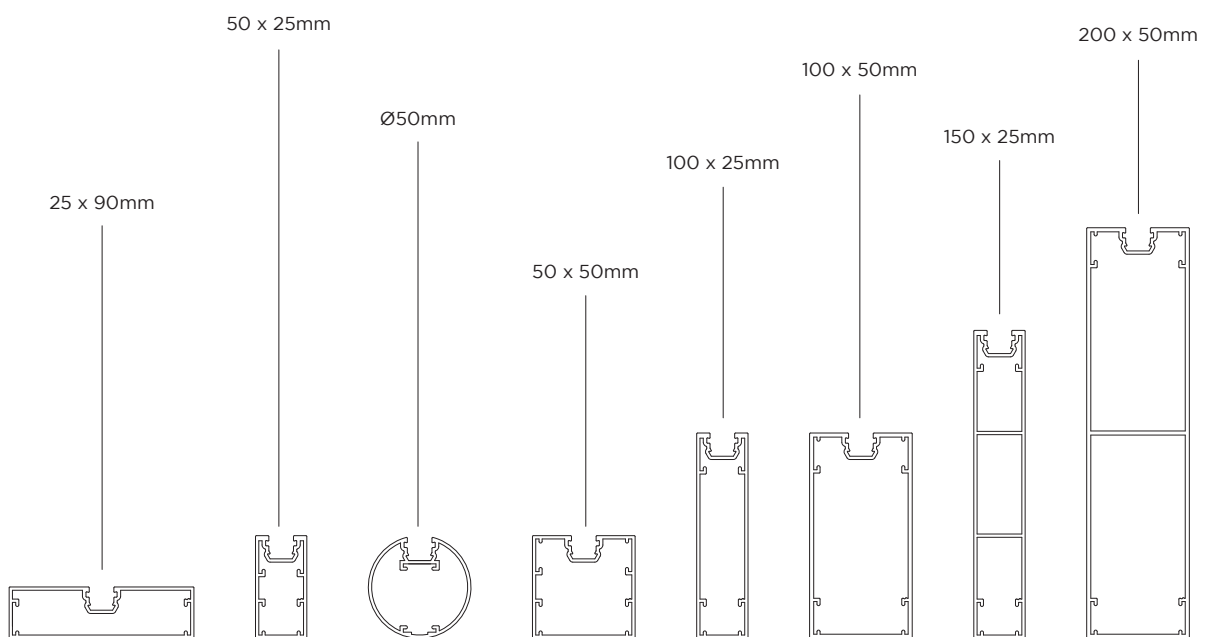

Finishes

Finishes | Power Coat

Apollo aluminium battens are available in all Dulux powder coat colours. Minimum order quantities on some non-standard powder coats may apply.

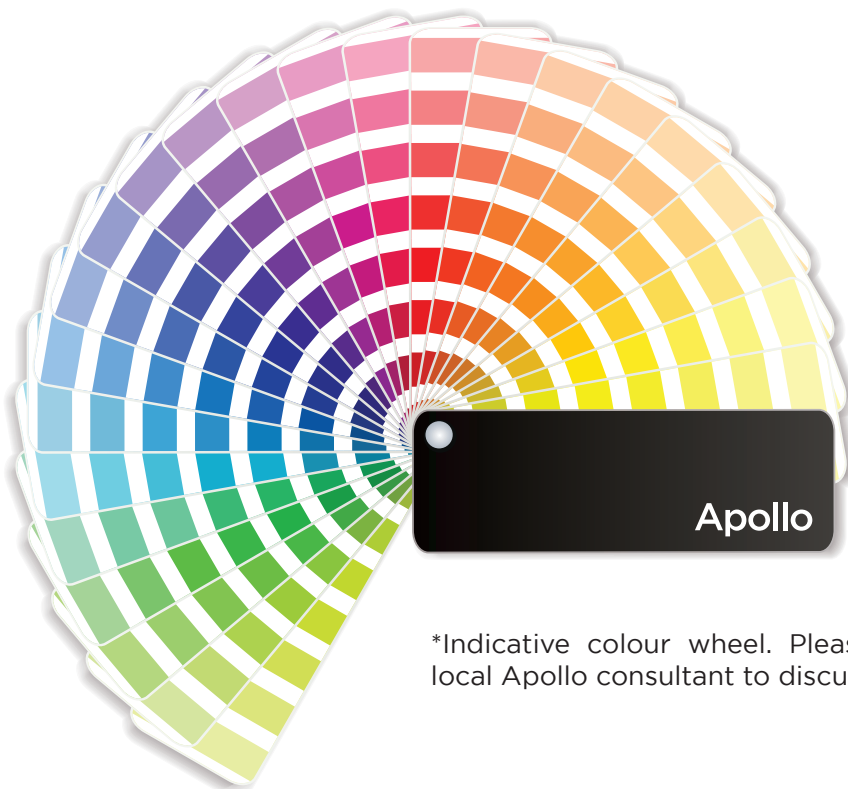
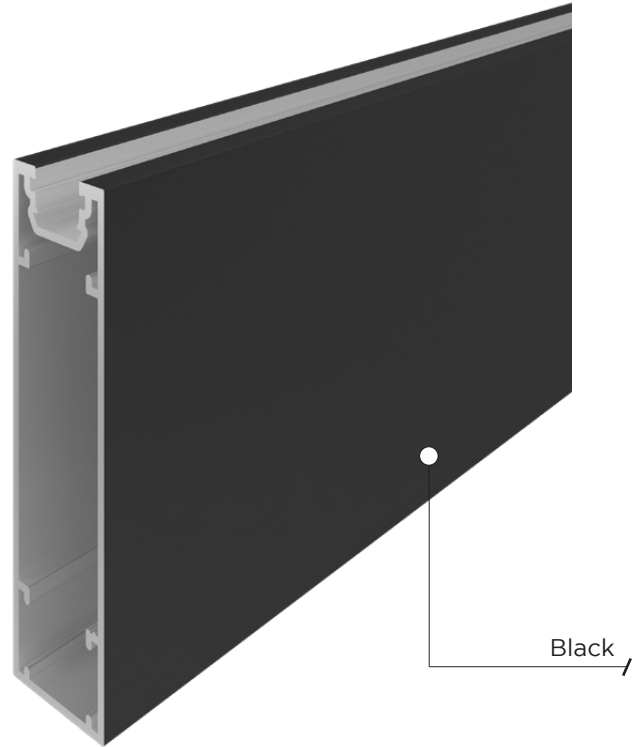
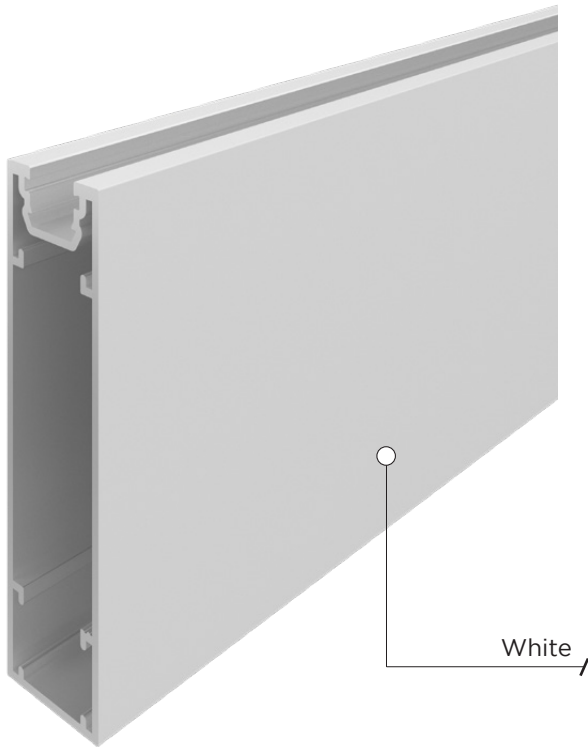

*Indicative colour wheel. Please contact your local Apollo consultant to discuss your options.

Finishes | Timber Effect

Apollo aluminium battens are available in 11 timber effect powder coat finishes.



Birchwood



Nordic White Oak



European Spruce



Natural Ash



Scarlet Oak



Blonde Oak



Amber Oak



Light Oak



Spotted Gum



Mahogany

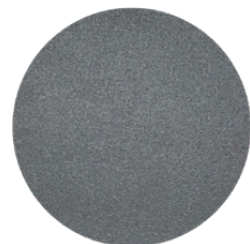

Black Ash

* Other timber effect powder coats available upon request.

Components

System Components

The Apollo Top Cross Rail (TCR) is supplied with integrated batten clips at the required centres for the project. Standard centres for the baffle clips are 100mm, 150mm & 200mm. Once the ceiling battens are clipped into the TCR, the batten clips are fully concealed.

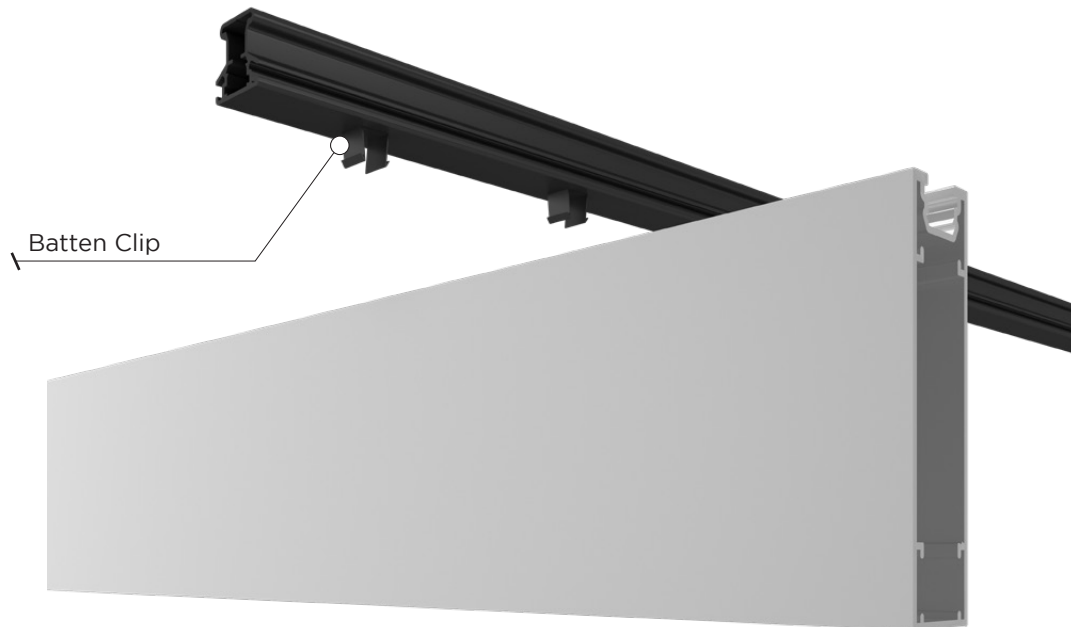

To keep the number of system components to a minimum, the friction fit joiners that are used to align the aluminium battens can also be used to connect the Top Cross Rails (TCR) to one another. The joiners are inserted in the top slot of the TCR.

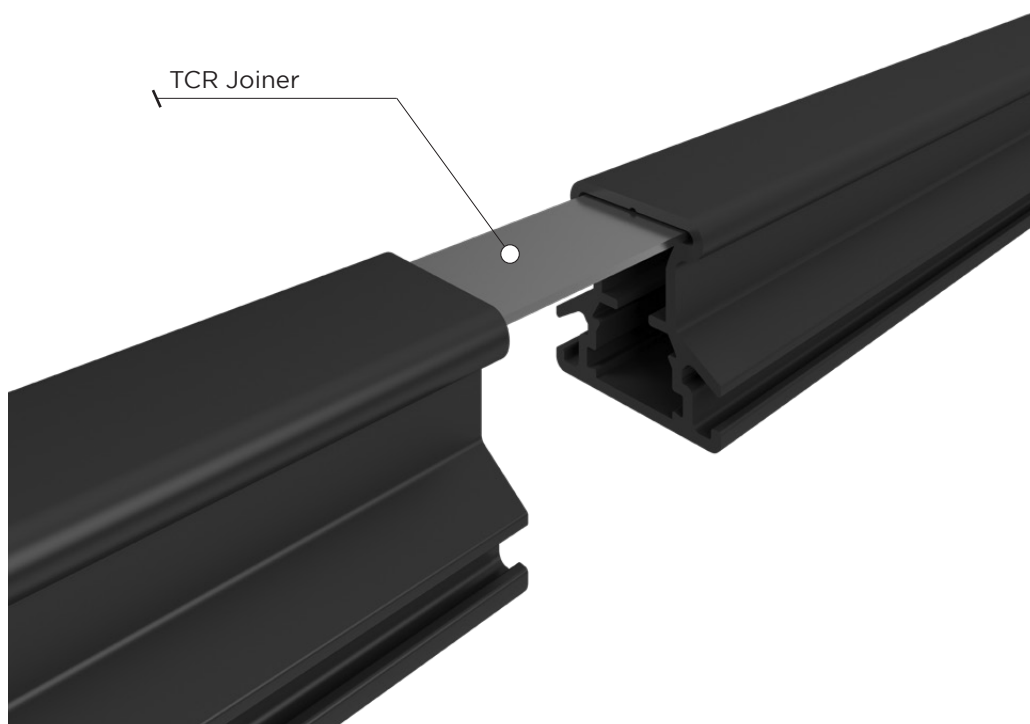

Where Apollo aluminium batten ends are visible, it's advised that end caps are fitted for a seamless look. These are powder coated to match the battens, with an easy installation of a simple push-fit connection.

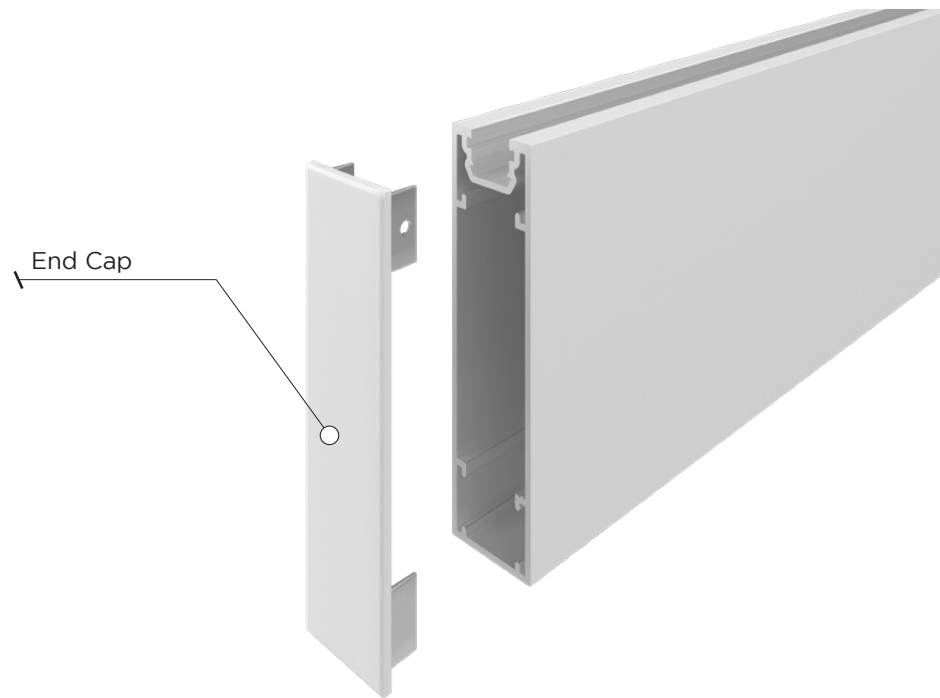

Internal keyways within each Apollo aluminium batten allow for friction fit joiners to be inserted, allowing for consistent alignment at the bottom of each batten profile.

If the battens we're to be installed with 90° corners, the Apollo system can accommodate this with a folded 90° joiner.

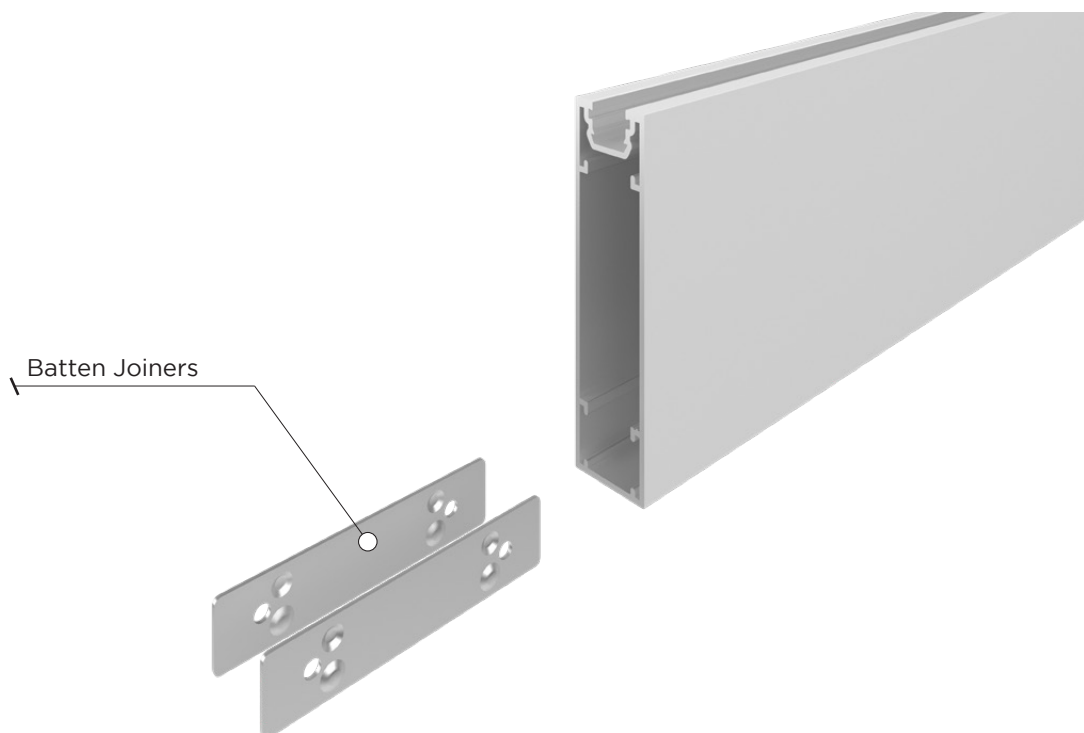

ACCESS

Access Hatches

The use of a drop-in hatch is the simplest solution to providing access with the Apollo Batten Ceiling. Hatches are built on site by the ceiling contractor with a typical size of 600 x 600mm. The batten clip at each end of the Access Hatch TCR is to be removed, so the TCR sits on top of the perpendicular batten in the ceiling, without clipping in and engaging.

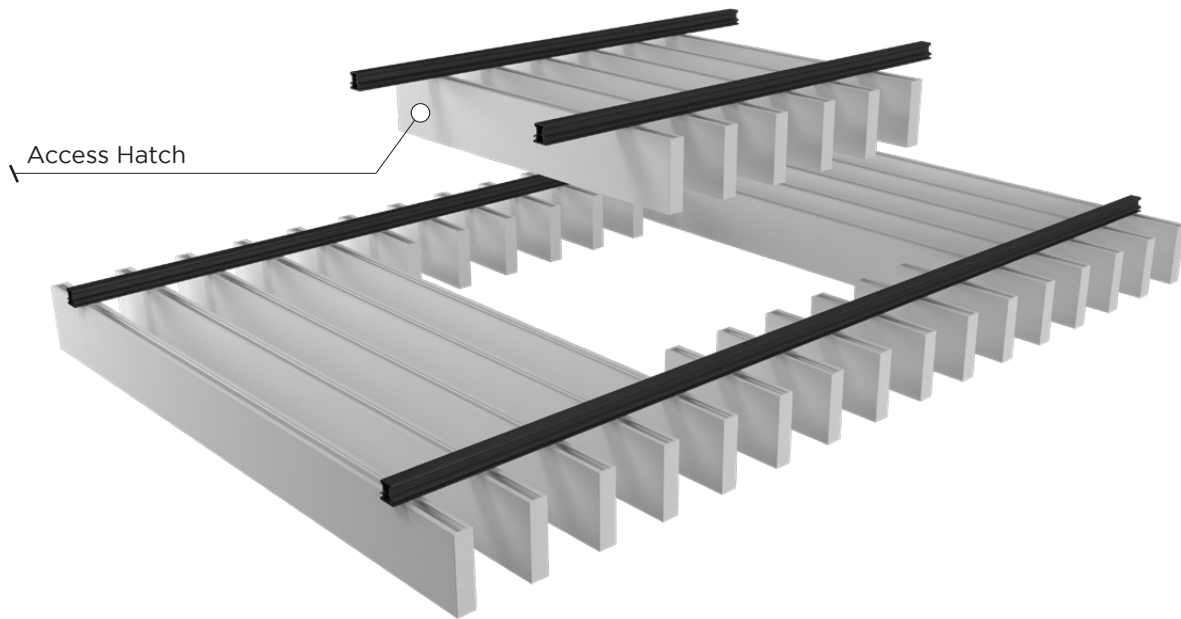

Performance

Performance Criteria



Acoustic Performance

There are three acoustic backing options available for the Apollo Aluminium Batten Ceiling.

THICKNESS	DENSITY	COLOUR	ACOUSTIC PERFORMANCE (NRC)	FIRE PERFORMANCE	SIZE
7mm	-	Black	0.5 NRC (25mm cavity)	Group 1	2400 x 568mm
25mm	35kg/m ³	Black	0.7 NRC	Group 1	2400 x 568mm
50mm	35kg/m ³	Black	0.9 NRC	Group 1	2400 x 568mm



Fire Performance

The Apollo Aluminium Batten Ceilings achieve a Group 1 rating as per Section 9 (n) of AS 5637.1-2015, the determination of the group number is based on the AS/NZS 3837-1998 test, and is deemed valid in the cone calorimeter for the assignment of National Construction Code (NCC) group number.

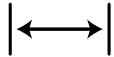

Maximum Batten Lengths Available

The Apollo Aluminium Batten's are supplied at 3600mm as standard, however can be manufactured up to a maximum length of 6000mm. Other lengths are available upon request.



Services Integration

Services which integrate into the Apollo Aluminium Batten ceiling system must not exceed 3kg/m³. Weights of over 3kg/m³ must be self-supporting. Please contact your local Apollo consultant to discuss your options.

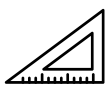

Maximum Cantilever

The maximum cantilever recommended for the Apollo Aluminium battens of any profile size is 300mm for interior applications.



Warranty

For interior applications, the Apollo Aluminium Batten Ceiling system comes with a 10 year warranty. Please contact your local Apollo consultant for your project specific warranty.



Apollo

03 9580 7800

hello@mbsarchitectural.com.au

VIC | 7 Haymer Court, Braeside 3195

QLD | 13 Pease Court, Bethania 4205