

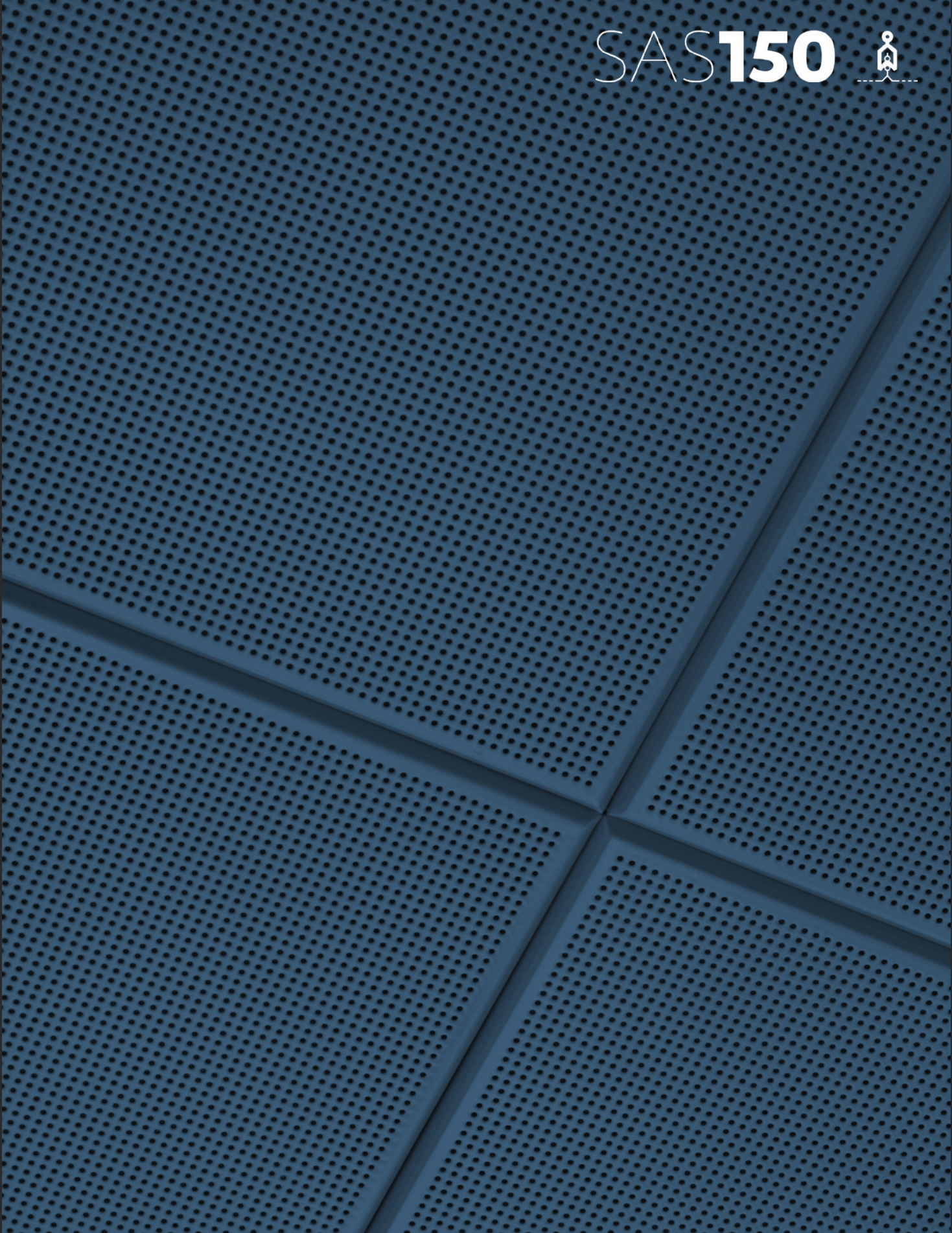

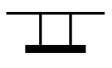

SAS**150** 



Overview

SYSTEM GROUP		GRID
		
Suspended Ceiling		Concealed Grid – SAS Shallow or Deep Omega Bar
TILE		
		
Clip-in		Bevelled edges Closed butt-joints
ACOUSTICS		
A-D		15-41dB
Absorption class		Insulation
ACCESS	SYSTEM WEIGHT	LIFE EXPECTANCY
	9kg/m² Approx.	25yr
Full – hinge and slide tiles	Based on 600 x 600mm tiles*	In excess of

*Note This includes the entire system and full associated components (suspension, tile, acoustic pad and associated fixings.)

SAS150

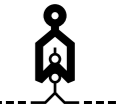

SAS150 offers all the benefits of SAS120, with the additional convenience of hinge-down access minimising risk of damage. Clip-in systems allow for upward cleaning pressure without dislodging or displacing tiles. If required, voids can be secured through the use of a simple clip mechanism.

Hospitals and food preparation areas are ideal examples of appropriate environments, however the system is suitable for numerous applications.

Module Sizes (mm) with 4mm bevel

300 x 300	500 x 500
300 x 600	500 x 1500
300 x 900	600 x 600
300 x 1200	600 x 1200
300 x 1500	750 x 750 with 2mm bevel

Bespoke module sizes and shapes are available on request.

Access

Hinge down and slide – The void is completely accessible with the use of a simple tool.

Alternatively, in areas where security is paramount optional security clips are available. This restricts access to the void to minimise security concerns.

Finishes

SAS150 is available in all standard SAS finishes, please refer to page 105. Bespoke finishes are available on request.

Perforations

Typically supplied with 1522 (available as stock item), 1820 or 2516. For our full range of perforations, please refer to page 83. Bespoke perforations are also an option.

Acoustic Materials

16mm deep, 80Kg density mineral wool pad with black tissue face, foil back and sides. Other acoustic materials are available, please refer to page 20.

Please note SAS150 is not suited to all SAS acoustic materials due to maximum loads on clip-in systems.

Service Integration

Tiles can be formed with apertures during manufacturing and post painted for integration with lights and other services.

Please note SAS150 tiles will support loads up to 2.5Kg. Pattresses can be used to support loads up to 6Kg. Anything in excess of 6Kg requires independent suspension.

Technical Support

Please contact our technical team for all questions relating to access, security, bespoke features, service integration or load support.

Additional System Information

The deep Omega Bar has a maximum spanning capability of 2000mm. The wide spanning bar requires 25% less primary channels, top fixings and brackets, saving installation time and materials.

Suspension centres should be reduced when using high performing dB panels due to the additional weight or where loads are applied to the system.

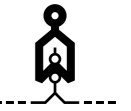
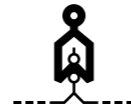

Perspective Drawing

- 1 Emac Hanger
- 2 Omega Bar to Channel Bracket
- 3 Emac Channel
- 4 SAS Omega Bar
- 5 Emac Wall Anchor
- 6 Omega Bar Splice
- 7 Perimeter Trim
- 8 Perimeter Wedge
- 9 SAS 150 Tile

*Lightweight installations only, see page 253 for full details.

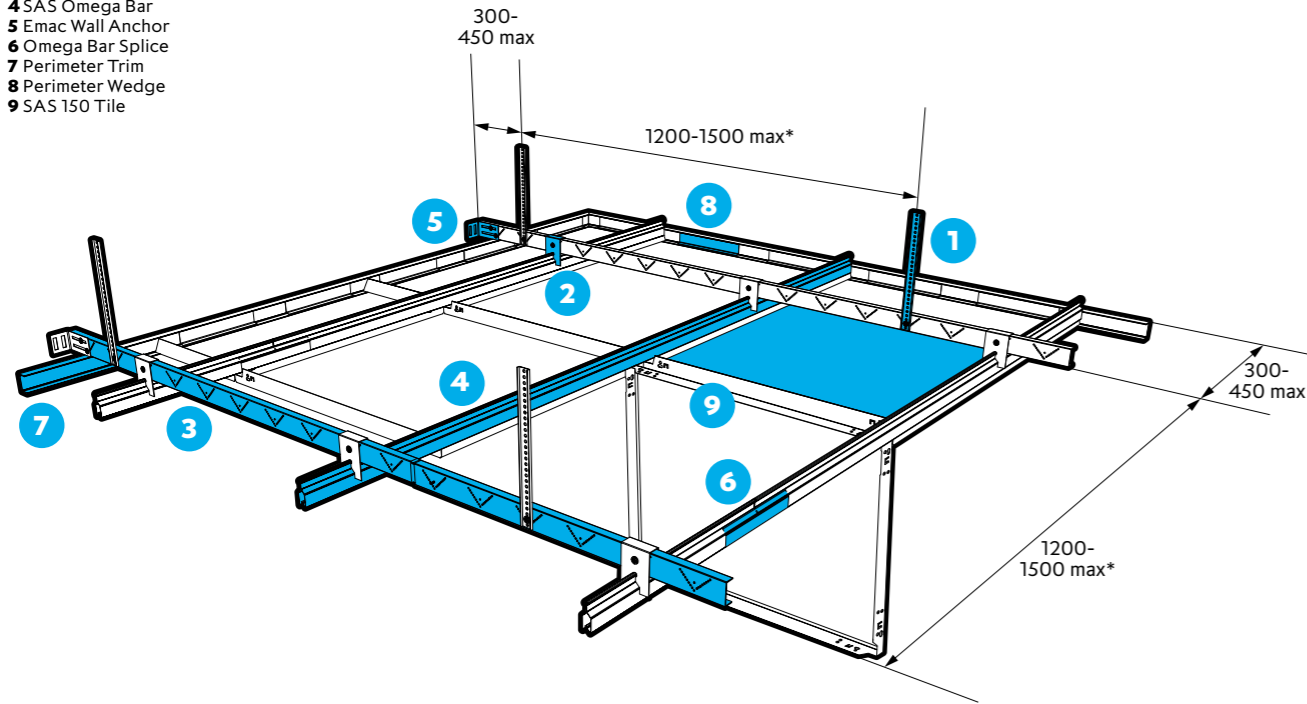

Section and detail drawings

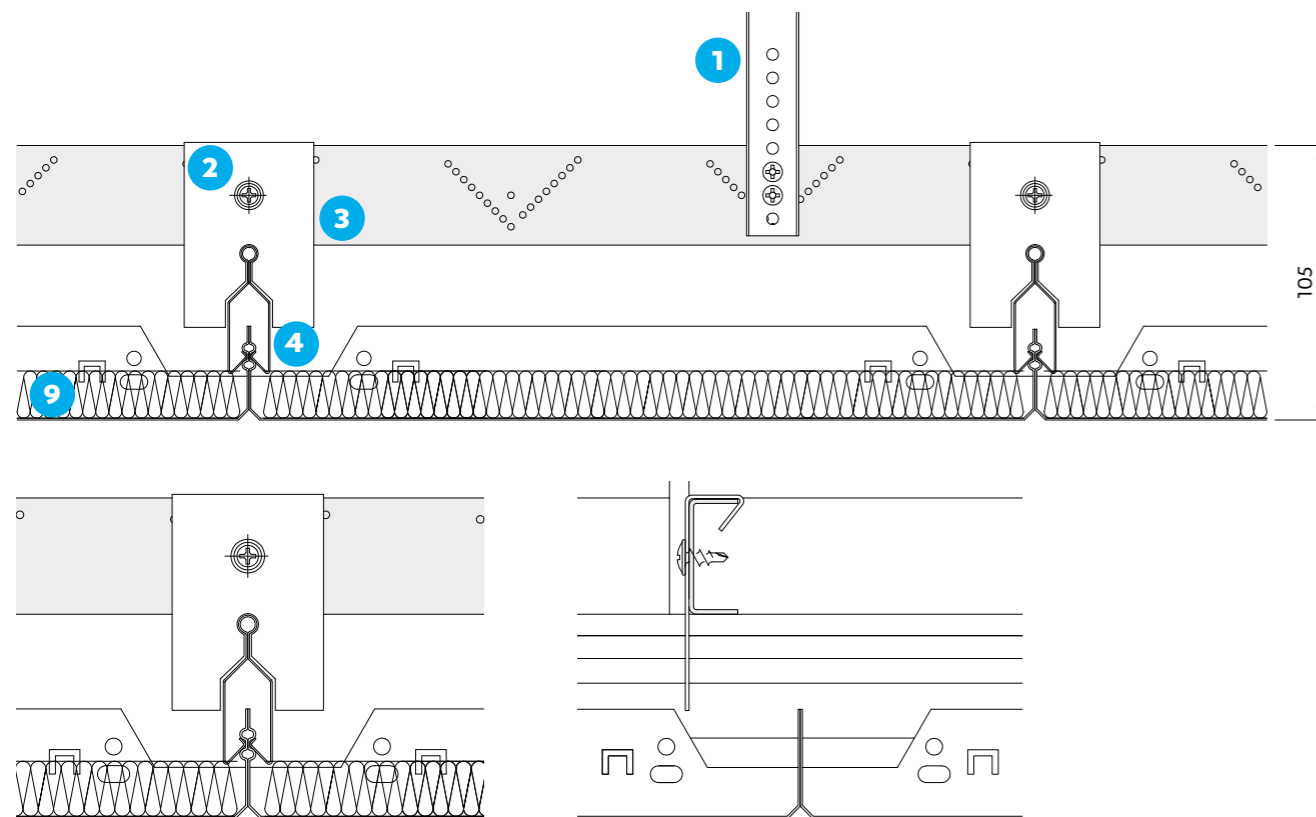

All dimensions are in mm.

Hinge and Slide Facility

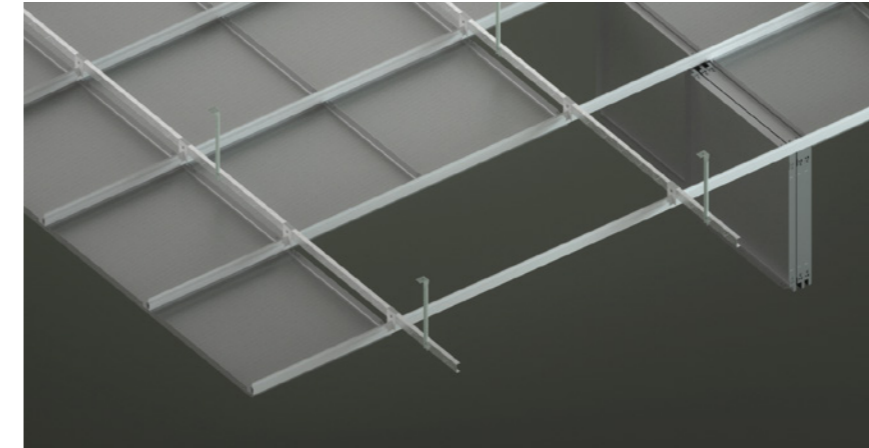

SAS150 allows every full tile to pivot and slide along the grid system. This feature facilitates easy access to large areas of the ceiling void for maintenance. Tiles are retained within the ceiling grid avoiding damage and eliminating the need for storage.

Service Integration

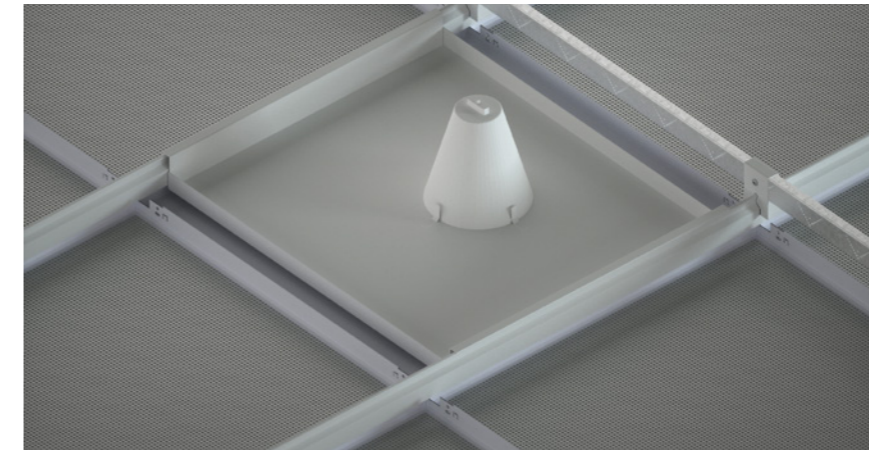

Lighting and other services can be integrated with SAS150. Modular lighting can be supported directly from the soffit. Where maximum point loads are exceeded (2.5Kg) the service must be supported independently or from the grid.

Loads in excess of 2.5Kg and up to 6Kg can be supported by an SAS Pattress. This distributes the load across the SAS Omega Bar and eliminates the need for complicated support arms. Loads in excess of 6kg must be supported independently. For more information on load support, please contact our technical design department.

Bulkhead Closure Panels

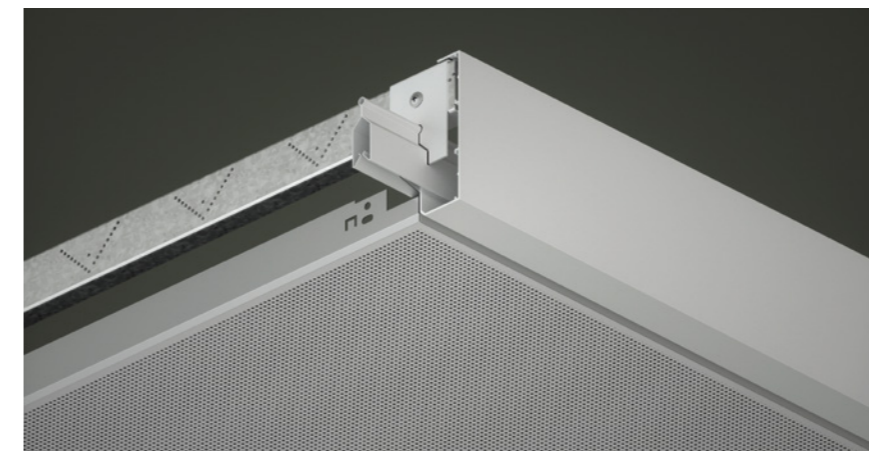

Bulkhead closure panels enable floating rafts and ceilings to be created using a standard clip in ceiling tile. The height of the closure panels can be manufactured to suit project requirements. For more information on closure panels, please contact our technical design department.



SAS**150**

Aldar HQ

Location
Abu Dhabi, U.A.E
Architect
MZ and Partners

Contractor
**ALDAR Laing
O'Rourke
Construction LLC**
Purpose
Commercial

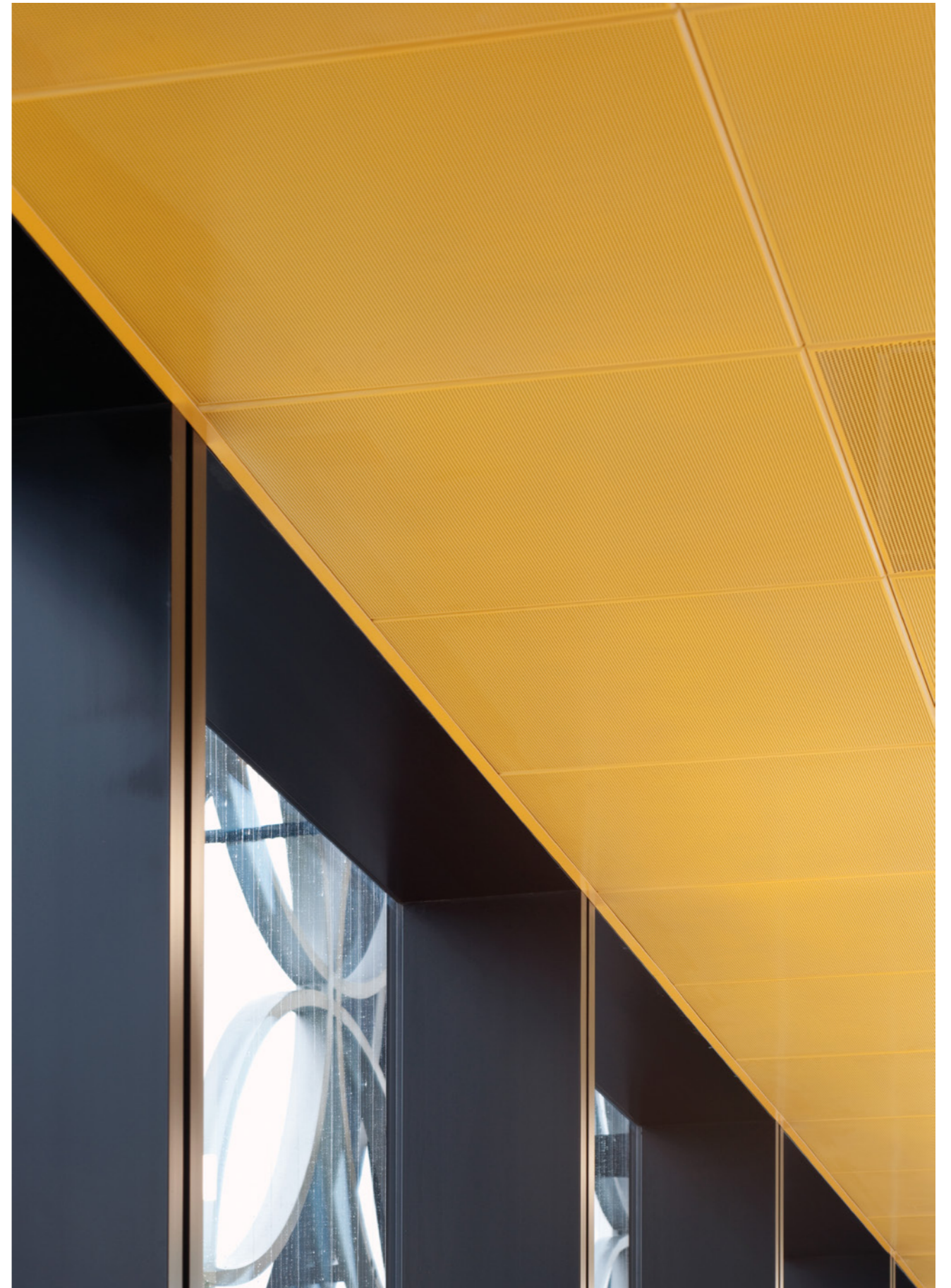

SAS**150**

Library of Birmingham

Location
Birmingham, UK
Architect
Mecanoo Architecten

Contractor
Carillion Plc
Purpose
Leisure

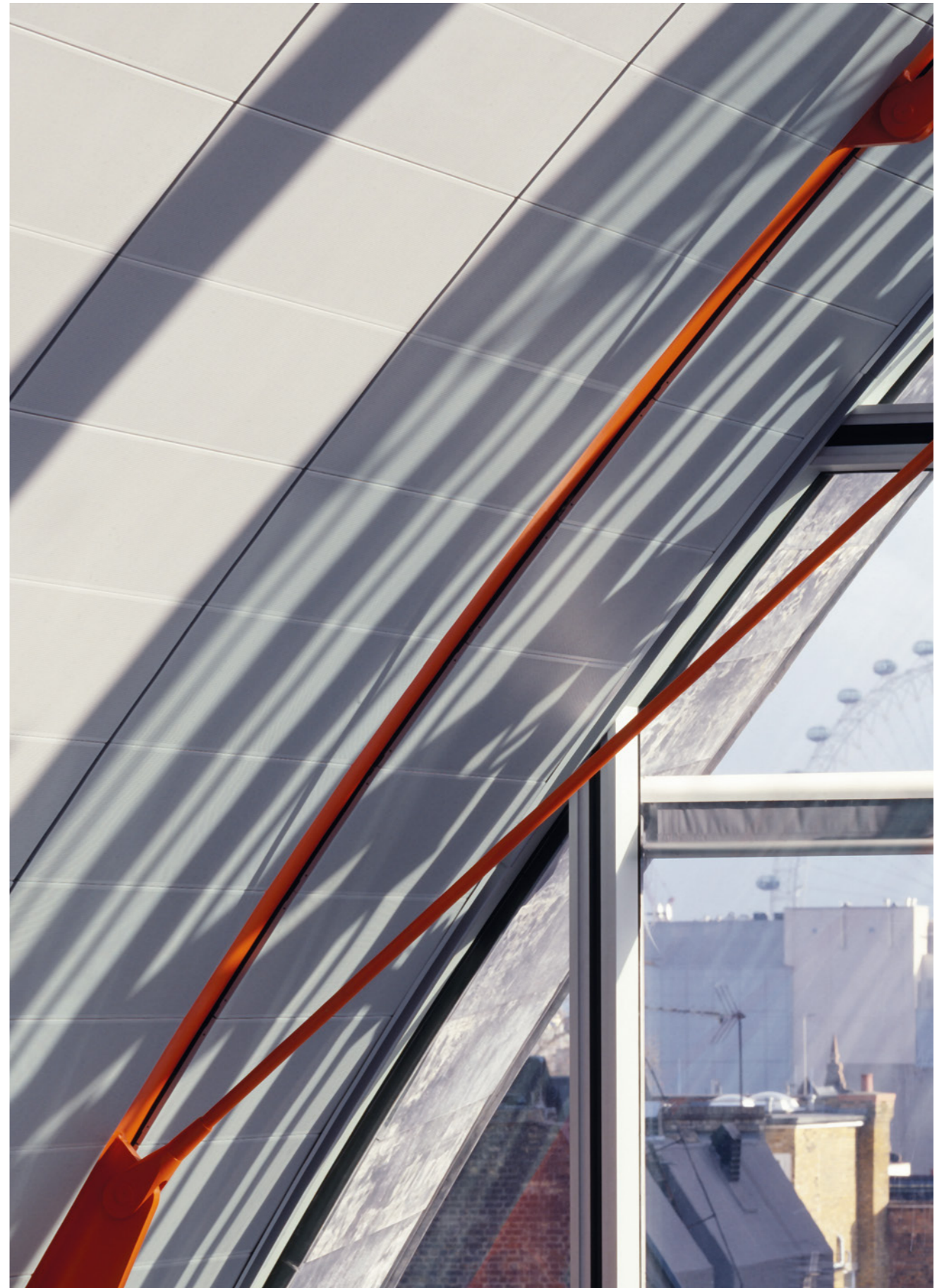

SAS**150**

Top
International Tower, ADNEC

Location
Abu Dhabi
Architect
**Artillery Architecture
& Interior Design**

Contractor
**Group 3 Engineers
and Contractors**
Purpose
Commercial

Bottom
BBC Broadcasting House

Location
**20 Portland Place,
London, UK**
Architect
**Sheppard Robson/
MJP Architects**

Contractor
Lend Lease
Purpose
Commercial

SAS**150**^{plus}

Ingeni Building

Location
London
Architect
**Richard Rogers
Partnership**

Contractor
John Sick & Son
Purpose
Commercial

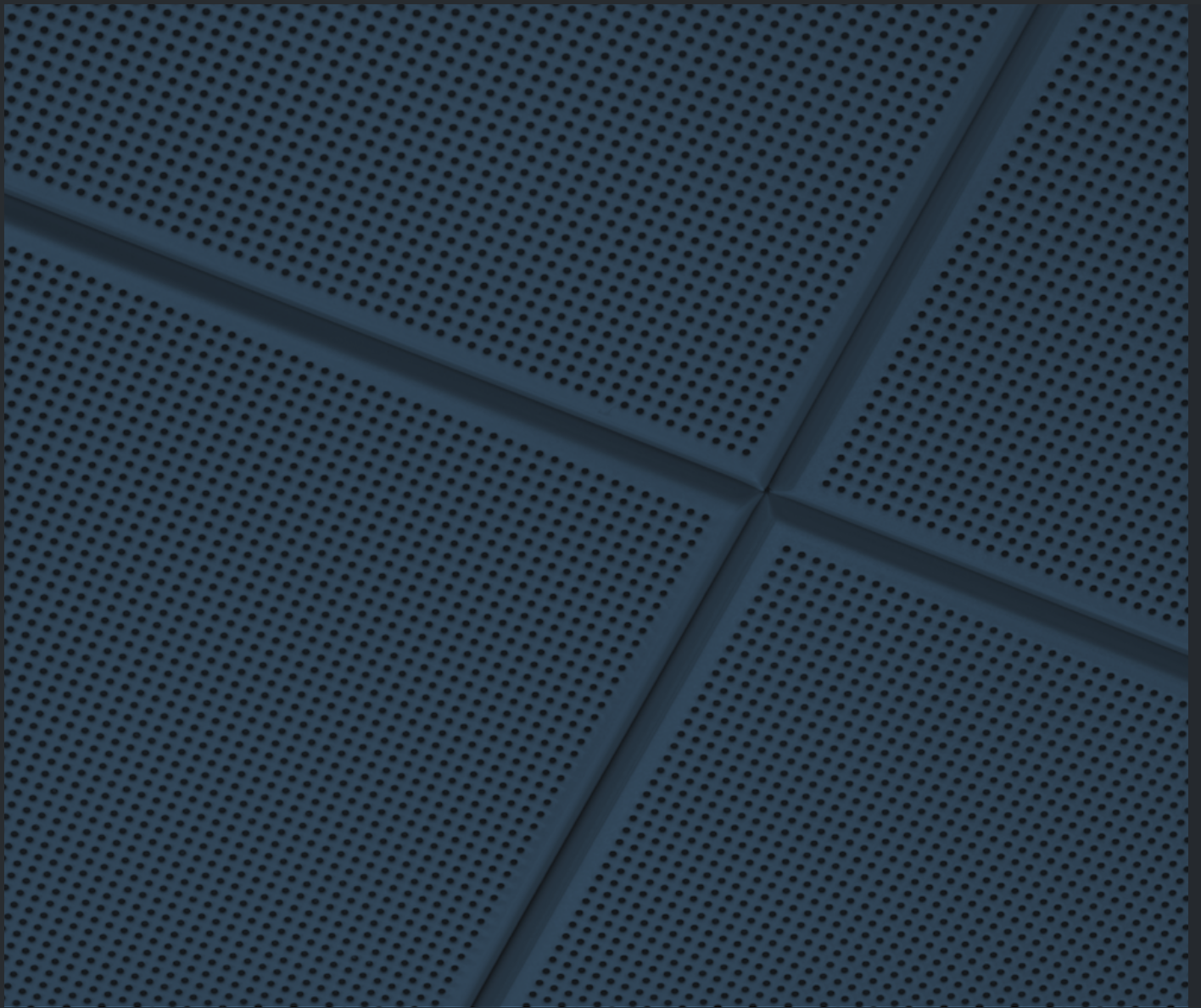

MBS

Architectural

**INSPIRED BY QUALITY.
DRIVEN BY INNOVATION.**

Architectural Ceiling & Wall Systems

Reach out to our team for support, samples and advice.
hello@mbsarchitectural.com.au | mbsarchitectural.com.au

VIC
03 9580 7800
7 Haymer Court
Braeside 3195

QLD
07 2116 0717
13 Pease Court
Bethania 4205