

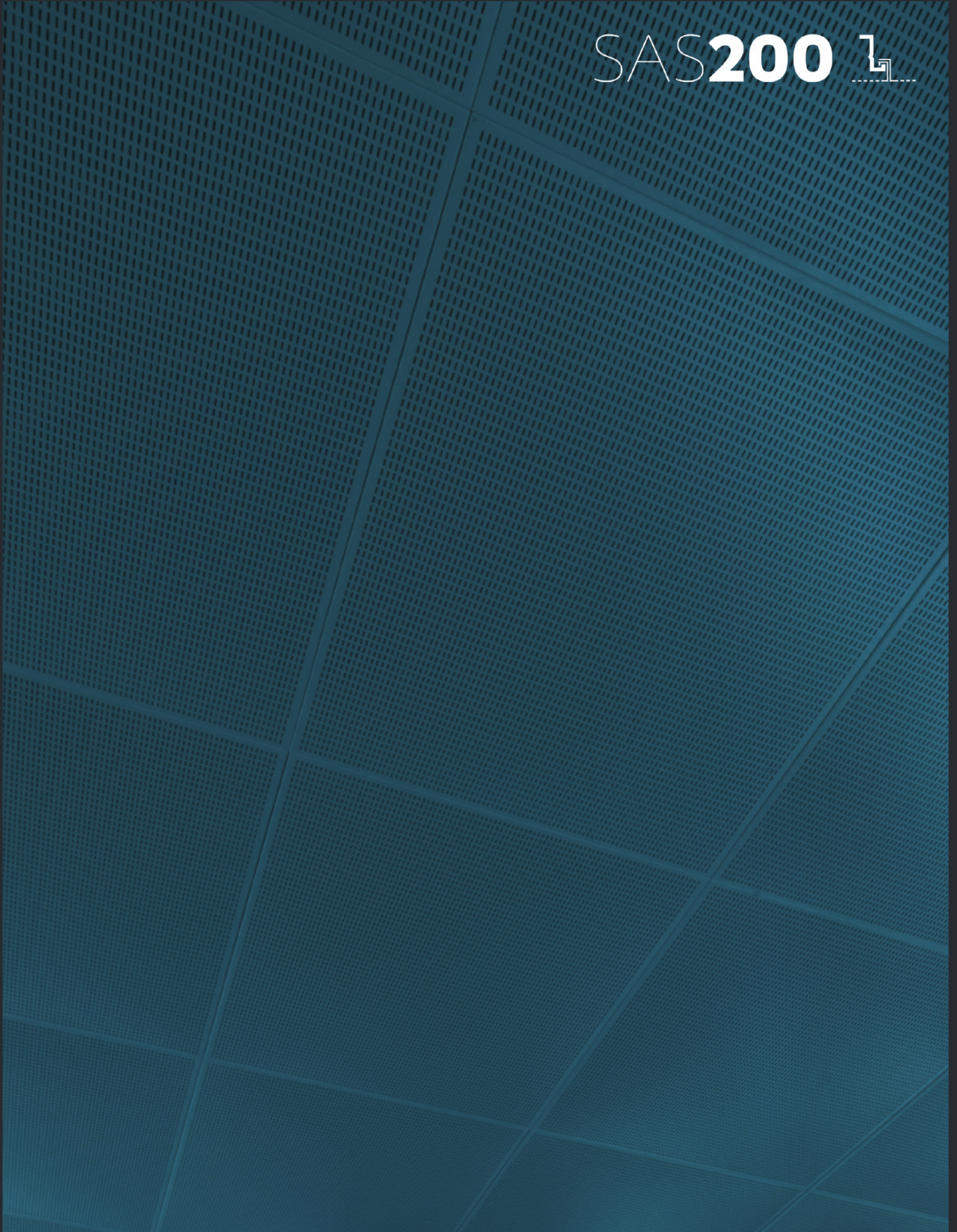





SAS200 



Overview

SYSTEM GROUP		GRID	
			
Suspended Ceiling		Concealed Grid SAS J-Bar suspension	
TILE			
			
Hook-on		Square edge	
ACOUSTICS			
A-D		15-41dB	
Absorption class		Insulation	
ACCESS	SYSTEM WEIGHT	LIFE EXPECTANCY	
	10kg/m² Approx.	25yr	
Lift and Tilt	Based on 600 x 600mm tiles 30mm deep*	In excess of	

***Note** This includes the entire system and full associated components (suspension, tile, acoustic pad and associated fixings.)

SAS200

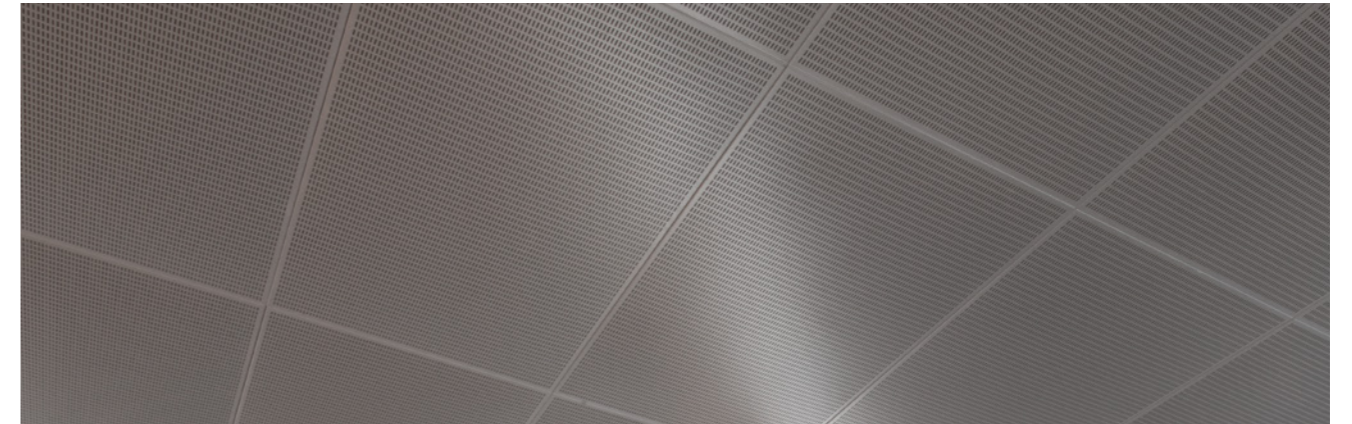
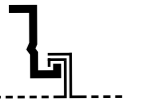

SAS200 is a concealed grid suspended ceiling system offering significant creative flexibility. The highly adaptable system is often used as a basis for fully bespoke designs. Due to its inherent versatility, the J-Bar hook on system can be used in a wide variety of applications.

Module Sizes

There are no standard tile sizes for SAS200. Tiles can be up to 3000mm in length and no less than 300mm wide. Bespoke module sizes and shapes are available on request.

Access

Tiles can simply be lifted and removed from the grid.

Finishes

SAS200 is available in all standard SAS finishes, please refer to page 105. Bespoke finishes are available on request.

Perforations

SAS200 can be manufactured with any standard SAS perforation. For our full range of perforations, please refer to page 83. Bespoke perforations are also an option.

Acoustic Materials

16mm deep, 80Kg density mineral wool pad with black tissue face, foil back and sides. Other acoustic materials are available, please refer to page 20.

Service Integration

Tiles can be formed with apertures during manufacturing and post painted for integration with lights and other services.

Please note Loads in excess of 6Kg require independent suspension.

Technical Support

Please contact our technical team for all questions relating to access, security, bespoke features, service integration or load support.

Please note Panels are supplied with a standard 3mm wide, black gasket.

SAS200

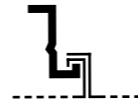

Perspective Drawing

- 1 Emac Hanger
- 2 Emac Channel
- 3 J-Bar to Channel Bracket
- 4 J-Bar
- 5 Emac Wall Anchor
- 6 J-Bar Splice
- 7 Perimeter Trim
- 8 Wedge
- 9 Tile

*Lightweight installations only, see page 253 for full details.

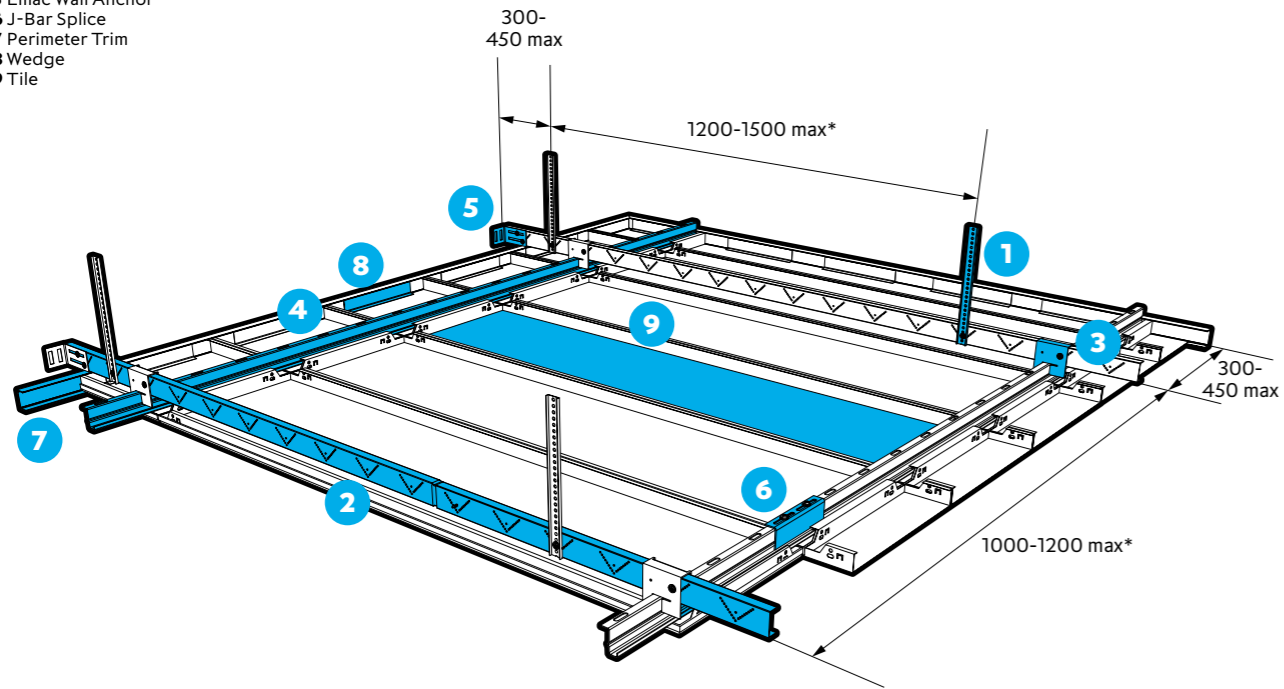

Section and detail drawings

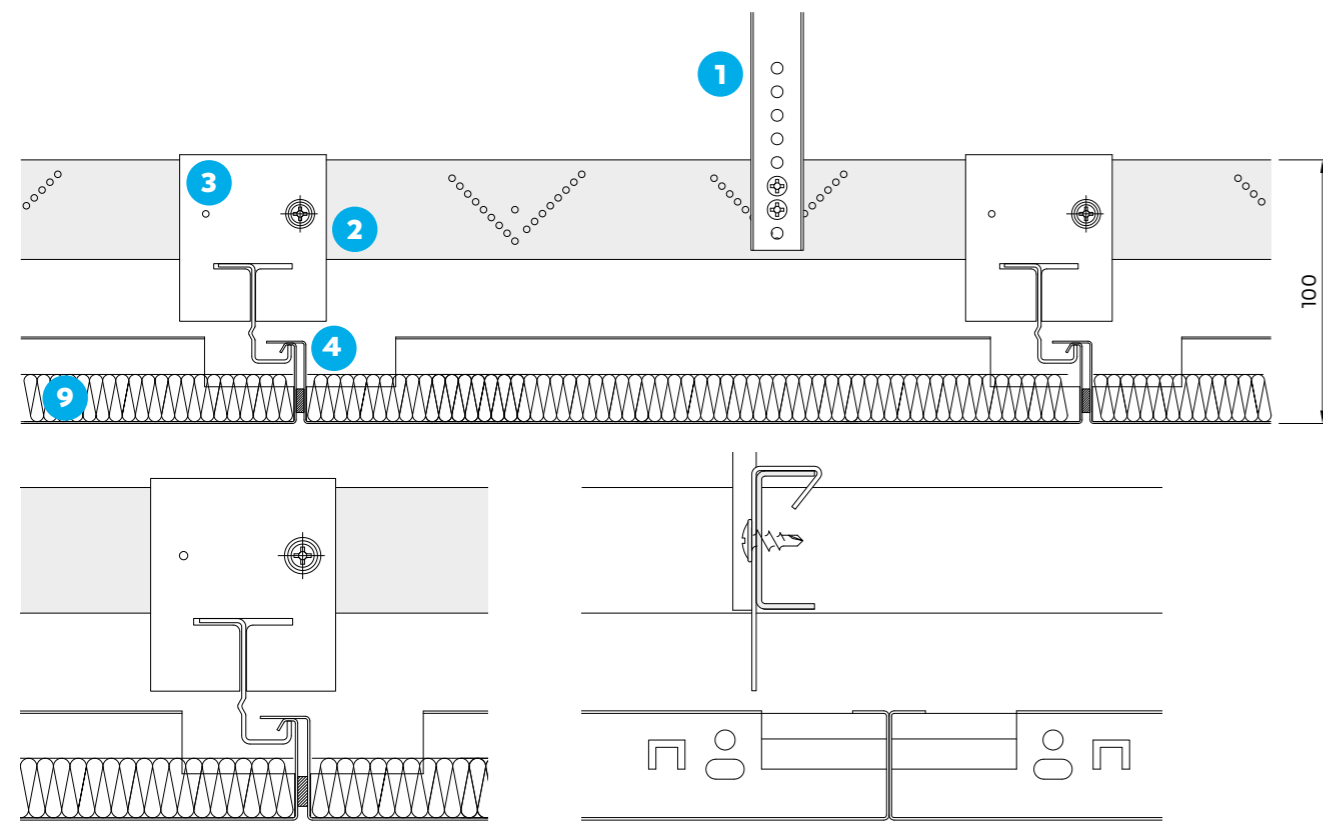

All dimensions are in mm.



SAS200

KPMG, Sovereign Street

Location
Leeds, UK
Architect
Sheppard Robson

Contractor
Morgan Sindell/ISG
Interior Exterior
Purpose
Commercial



SAS200

Audi, Milton Keynes

Location Milton Keynes, UK	Contractor BDB Design Build Ltd
Architect SDA Architects	Purpose Retail



SAS200^{2nd}

Ropemaker Place, London

Location London, UK	Contractor Mace Ltd
Architect Arup Associates	Purpose Commercial



MBS

Architectural

**INSPIRED BY QUALITY.
DRIVEN BY INNOVATION.**

Architectural Ceiling & Wall Systems

Reach out to our team for support, samples and advice.
hello@mbsarchitectural.com.au | mbsarchitectural.com.au

VIC
03 9580 7800
7 Haymer Court
Braeside 3195

QLD
07 2116 0717
13 Pease Court
Bethania 4205