

Job Safety Analysis

Use These Forms Before You Begin Any Job to Alert You of Any Hazards That May Exist

Page 1 of 8

Engine Removal and Installation

Customer Name:	Job Location:	Unit #:	Job#:
-----------------------	----------------------	----------------	--------------

REQUIRED PERSONAL PROTECTION EQUIPMENT:	MSDS(s) ASSOCIATED WITH THE JOB:
Hard hat, ear plugs, safety glasses with side shields, gloves, steel toed boots, fall protection & all other required site specific personal protective equipment.	Chemicals normally used on the crane or stored on Service trucks

*To improve readability and comprehension of this field document, we have detailed all common hazards and the recommendations for safe work at the beginning of this JSA. It is understood and assumed that any time during the assembly of this crane, any or all these hazards may become relevant. **This JSA is to be used in conjunction with the operator's manual. If there is ever a discrepancy between the two the operator's manual takes precedence.***

Common Hazards	Safe Job Practices
<ul style="list-style-type: none"> • Slips, Trips and Falls 	<ul style="list-style-type: none"> • Use of personal fall protection system is mandated when working where employees are exposed to falls greater than 4 feet. • Wear shoes with a highly slip-resistant sole material. Clean any mud or debris from shoes before entering the crane cab or climbing onto crane. • Do not use top of mast, boom, or jib as walkways (unless they have optional catwalks). • Use both hands and handrails, steps and ladders provided to climb onto and off crane. • Lift tools and other equipment which cannot be carried in pockets or tool belts onto and off crane with hand lines or hoists. • Good House keeping
<ul style="list-style-type: none"> • Crushing Injury Hazard 	<ul style="list-style-type: none"> • Barricade all accessible areas to crane so personnel cannot be struck or crushed when upper works is swung. • Do not climb on or off crane while upper works is being swung or crane is being traveled. • Signal operator that you need to climb on or off crane. • Operator: do not swing or travel while personnel are climbing on or off crane. Stop swing and travel motions. Apply swing brake and turn on Travel Brake. • Use of dedicated spotters and signal persons when flying objects with cranes. • Use of tag lines when a rotating load may become a hazard.
<ul style="list-style-type: none"> • Struck By/ Caught Between/Pinch Point Hazards 	<ul style="list-style-type: none"> • Hard Hats and Safety Glasses shall be worn at all times during the assembly/disassembly of this crane. • Never handle wire rope with bare hands. Always wear heavy-duty gloves to prevent being cut by broken wires. • Use extreme care when handling coiled pendants. Stored energy can cause coiled pendants to uncoil quickly with considerable force. • Do not attempt to maintain or repair any part of crane while engine is running, unless absolutely necessary. • If engine must be run, keep your clothing and all parts of your body away from moving parts. Maintain constant verbal communication between person at controls and person performing maintenance or repair procedure. • Do not use your hands to check for air and hydraulic oil leaks • Relieve pressure before disconnecting air, coolant, and hydraulic lines and fittings. • Do not attempt to lift heavy components by hand. Use a hoist, jacks, or blocking to lift components.

Job Safety Analysis

Use These Forms Before You Begin Any Job to Alert You of Any Hazards That May Exist

Page 2 of 8

Engine Removal and Installation

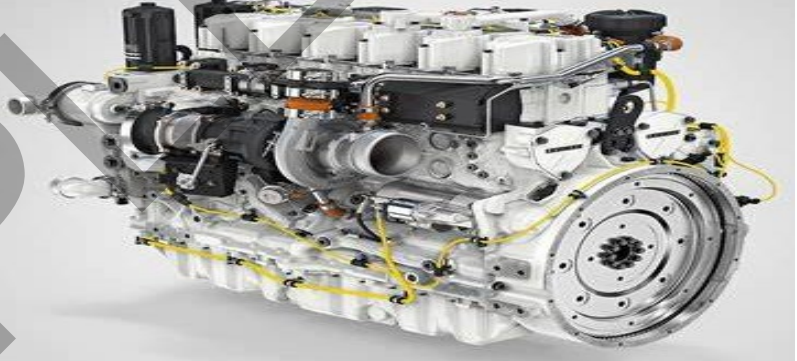
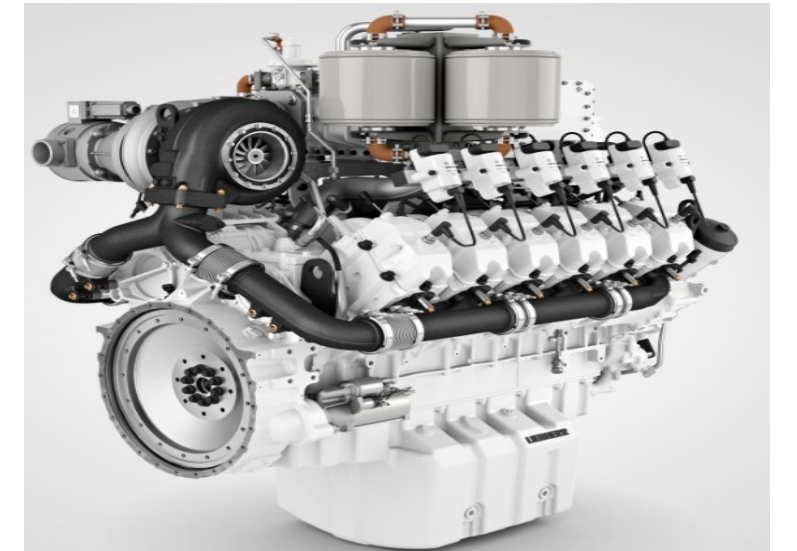
<ul style="list-style-type: none">• Struck By/ Caught Between/Pinch Point Hazards	<ul style="list-style-type: none">• Store tools, oil cans, spare parts, and other necessary equipment in toolboxes. Do not allow these items to lie around loose in operator's cab or on walkways and stairs.• Use of dedicated spotters to direct and signal all vehicle traffic.• Before a crew member goes to a location that is out of view of the operator and is either in, on, or under the equipment, or near the equipment (or load) where the crew member could be injured by movement of the equipment (or load), the crew member must inform the operator that he/she is going to that location. Where the operator knows that a crew member went to a location covered by the above sentence, the operator must not move any part of the equipment (or load) until the operator is informed in accordance with a prearranged system of communication that the crew member is in a safe position.	
	<ul style="list-style-type: none">• Select a suitable location for Engine Staging. It must be firm, level, and be free of obstructions. It should have enough open space to accommodate the crane, the length of boom, and - if required - movement of an assist crane or other equipment. If possible, secure the area to keep unauthorized personnel and vehicles away.• Sling Engine at an appropriate spot and around the engines so not to slip or move. Use softeners as needed. If the engine is slung incorrectly, it can fall or cause machine damage	
<ul style="list-style-type: none">• Dropped Loads and equipment damage	<ul style="list-style-type: none">• Inspect all rigging prior to the start of the day and before each use to ensure rigging is not damaged and capable of lifting the load safely.• Check load capacities of each piece of rigging to ensure proper use.• Look for tearing or cuts on the rigging• Ensure hooks and latches are in place and in good working order• Inspect softeners to make sure they will protect the rigging against sharp edges	

Job Safety Analysis

Use These Forms Before You Begin Any Job to Alert You of Any Hazards That May Exist

Page 3 of 8

Engine Removal and Installation

<ul style="list-style-type: none">· Designate Staging / Work area	<ul style="list-style-type: none">· Select a good location to stage the new engine and to place the old one after removal· Ensure ground conditions are firm, level and uniformly supportive.· Select an area large enough and free of any underground or overhead obstructions or hazards to accommodate the crane, assist crane, and the movement of trailers.· Maintenance area should not interfere or pose a hazard to other onsite personnel. Area should be clearly marked and barricaded.· There should be at least 2 feet of clearance between the counterweights and nearest obstacle of the assist crane.· Ground support as specified in the erection drawings is complete and in compliance with the stated requirements.
<ul style="list-style-type: none">· Assist Crane Requirements (If used)	<ul style="list-style-type: none">· The assist crane shall be sized in accordance with site restrictions and manufacturers specifications.· Site conditions and matting must be suitable for maximum loading of the assist crane.· Assist crane will assembled in accordance with manufacturer's instructions.
<ul style="list-style-type: none">· Rigging Failure	<ul style="list-style-type: none">· Rigging shall be inspected per applicable OSHA/ASME standards, at a minimum, daily and prior to use. Examples of unserviceable rigging would be bird caging, kinks, and broken wires.
<ul style="list-style-type: none">· Electrical Shock Hazard	<ul style="list-style-type: none">· Ensure adequate clearance from power lines is continuously maintained per ASME B30.5.
<ul style="list-style-type: none">· Operational Test Loads (if required)	<ul style="list-style-type: none">· Test loads shall not exceed 100% of the manufacturers load rating. Any request to load test a crane above the manufacturers load rating must be approved by a Regional Vice President.· Test loads shall never exceed 110% of manufacturers load rating.· Test loads must be freely suspended. Testing using static loads is prohibited.· All rigging must be inspected and approved prior to load testing.· The weight and radius of the load test shall be determined by:<ul style="list-style-type: none">- Manufacturers load chart.- Site Conditions.- Winch line pull, (i.e., the test load must be lifted while staying within the line pull capacity of the drum being utilized).

Note: At no time will a trainee, apprentice, or an oiler operate any crane during the assembly, reconfiguration, and/or disassembly process or while the crane is in bypass.

Job Safety Analysis

Use These Forms Before You Begin Any Job to Alert You of Any Hazards That May Exist

Page 4 of 8

Engine Removal and Installation

BASIC JOB STEPS	POTENTIAL HAZARDS	SAFE JOB PRACTICES
<ul style="list-style-type: none"> • Work area set up and evaluation <ul style="list-style-type: none"> ○ Walk the area for any recognized safety hazards ○ Review and amend the JHA based on initial evaluation. ○ <i>Prep work area for staggng of engine to be removed.</i> ○ <i>Set staging area for new engine to be installed</i> 	<p>See Common Hazards Above</p> <p>Crushing hazards, Pinch Points Damage to equipment, Caught between Moving Equipment, slips trips and falls.</p> <p><i>NOTE Make sure that the area has been barricaded. Set up area completely for new engine to be placed prior to moving on the next step. Work with Site contact to provide a spotter if necessary due too congested work area and moving equipment prior to removal.</i></p>	<p><i>See Safe Job Practices Above</i></p> <p>Good clear communication with fellow workers</p> <p>Utilize Stop work obligation, Barricade work area.</p> <p>Site will provide a flagger to direct equipment or traffic away from the work area.</p> <p>Inspect equipment before use.</p> <p>Gloves to be always worn for hands on work</p>
<ul style="list-style-type: none"> • Off load trucks <ul style="list-style-type: none"> ○ Off load engine that is to be installed in to crane in staging area. 	<p>See Common Hazards Above</p> <p>Crushing hazards, Pinch Points Damage to equipment, Caught between Moving Equipment, slips trips and falls. Dropped loads. Falling objects</p> <p><i>NOTE Make sure that the area has been barricaded. Set up area completely for new engine to be placed prior to moving on the next step. Work with Site contact to provide a spotter if necessary due too congested work area and moving equipment prior to removal.</i></p>	<p><i>See Safe Job Practices Above</i></p> <p>Communication with fellow workers,</p> <p>Utilize Stop work obligation, Flagger to direct equipment or traffic away from the lifting zone</p> <p>Inspect equipment before use.</p> <p>Inspect all rigging for visible damages and remove from service if defects are found.</p> <p>Keep all non-essential employees away from the area during liftin operations.</p> <p><i>Use of designated spotter to direct truck drivers.</i></p>
<ul style="list-style-type: none"> • Disconnect existing Engine <ul style="list-style-type: none"> ○ <i>Disconnect Battery</i> ○ <i>Attach the rigging to the engine to avoid any unnecessary movement of the engine.</i> ○ <i>Remove all hoses, wired connections and bolts securing the engine to the engine compartment</i> ○ <i>Make sure rigging is properly secured with weight on the rigging but not enough to lift</i> ○ <i>Stop work. Make sure all attachments and connections to the engine are removed</i> ○ <i>Remove engine from compartment</i> 	<p>See Common Hazards Above</p> <p>Crushing hazards, Pinch Points, Hydraulic leaks Damage to equipment, caught between, Spills Moving Equipment</p> <p><i>NOTE Double check the engine attachments to the frame and body. Ensure all hoses and wiring is secured away from the engine before lifting. Clear the area of any non-essential workers not involved in the lift.</i></p>	<p><i>See Safe Job Practices Above</i></p> <p>Communication,</p> <p>Keep hand out of the line of fire.</p> <p>All hoses should be purged of liquid.</p> <p>Request site to assist with spill control/prevention.</p> <p>Flagger to continue to direct traffic away from the work area</p> <p>Gloves to be always worn for hands on work</p>

Job Safety Analysis

Use These Forms Before You Begin Any Job to Alert You of Any Hazards That May Exist

Page 5 of 8

Engine Removal and Installation

<ul style="list-style-type: none"> ● Rig up and Lift Engine <ul style="list-style-type: none"> ○ Sling the engine properly so the rigging will not move or slip. If the engine is slung wrong, it can fall or cause machine damage. ○ Extend outriggers fully and set-up Assist machine horizontally. For engine lift ○ Check the area to make sure there are no obstruction or persons in the lift radius. ○ Assign one signal person ○ Double check compartment where engine will be placed after removal ○ Conduct pre lift discussion and lift for placement in compartment ○ Remove engine from compartment 	<p>See Common Hazards Above</p> <p>Tipping Hazard, crushing hazards, Pinch Points, Hydraulic leaks, Damage to equipment, caught between, Moving Equipment, Fire Hazard, Falling objects, Hydraulic Oil Spills</p> <p>NOTE Make sure that all hose and fuel connections are still securely covered to avoid any leaks after the engine is removed.</p>	<p>See Safe Job Practices Above</p> <p>Continues housekeeping to avoid tripping hazards Gloves to be always worn for hands on work Communication and Stop work obligation Flagger to keep equipment, traffic and outside employees out of the area. Ensure fire extinguisher is close and good working order Barricade area and keep loose tools and parts secured Site to provide spill prevention and control</p>
<ul style="list-style-type: none"> ● Prep New Engine for Installation <ul style="list-style-type: none"> ○ Prep all connection and wiring ports and connections for easy hook up after install ○ <i>Clean area of any tripping hazards and store and secure any loose items.</i> ○ <i>Make sure that there are no hoses or connections that can be caught or hung-up during installation</i> 	<p>See Common Hazards Above</p> <p>Crushing hazards, Pinch Points, Hydraulic leaks Damage to equipment, caught between, Spills Moving Equipment</p> <p>NOTE Make sure that any item protruding out from the engine is secured back to avoid any hang ups during installation</p>	<p>See Safe Job Practices Above</p> <p>Gloves to be always worn for hands on work Communication, Keep hand and extremities out of the strike zone. Stop work obligation Site to provide spill prevention/ control flagger to continue to direct all types of traffic away from the barricaded area.</p>

Job Safety Analysis

Use These Forms Before You Begin Any Job to Alert You of Any Hazards That May Exist

Page 6 of 8

Engine Removal and Installation

<ul style="list-style-type: none"> • Rig up and Lift Engine <ul style="list-style-type: none"> ○ Sling the engine properly so the rigging will not move or slip. If the engine is slung wrong, it can fall or cause machine damage. ○ Extend outriggers fully and set-up Assist machine horizontally. For engine lift ○ Check the area to make sure there are no obstruction or persons in the lift radius. ○ Assign one signal person ○ Double check compartment where engine will be placed after removal ○ Conduct pre lift discussion and lift for placement in compartment ○ Set engine in compartment. 	<p>See Common Hazards Above</p> <p>Tipping Hazard, crushing hazards, Pinch Points, Hydraulic leaks, Damage to equipment, caught between, Moving Equipment, Fire Hazard, Falling objects, Hydraulic Oil Spills</p> <p>NOTE Make sure that all hose and fuel connections are still securely covered to avoid any leaks after the engine is removed. Make sure Engine compartment is clear for installation</p>	<p><i>See Safe Job Practices Above</i></p> <p>Continues housekeeping to avoid tripping hazards Gloves to be always worn for hands on work Communication and Stop work obligation Flagger to keep equipment, traffic and outside employees out of the area. Ensure fire extinguisher is close and good working order Barricade area and keep loose tools and parts secured Site to provide spill prevention and control</p>
<ul style="list-style-type: none"> • Install Engine <ul style="list-style-type: none"> ○ <i>Leave Rigging secured after installation until bolting to ensure no unnecessary movement on the engine occurs until secured.</i> ○ <i>After bolts are secured remove rigging and begin final installation</i> 	<p>See Common Hazards Above</p> <p>Tipping Hazard, crushing hazards, Pinch Points, Hydraulic leaks, Damage to equipment, caught between, Moving Equipment, Fire Hazard, Falling objects, Hydraulic Oil Spills</p> <p>NOTE Make sure that all hose and fuel connections are still securely covered to avoid any leaks after the engine is removed. Make sure Engine compartment is clear for installation</p>	<p><i>See Safe Job Practices Above</i></p> <p>Communication, Keep hand out of the line of fire. All hoses should be purged of liquid. Request site to assist with spill control/prevention. Flagger to continue to direct traffic away from the work area Gloves to be always worn for hands on work</p>

Job Safety Analysis

Use These Forms Before You Begin Any Job to Alert You of Any Hazards That May Exist

Page 7 of 8

Engine Removal and Installation

BASIC JOB STEPS	POTENTIAL HAZARDS	SAFE JOB PRACTICES
<ul style="list-style-type: none"> ● Final Engine installation <ul style="list-style-type: none"> ○ Secure all hoses and Electrical wiring ○ Ensure all hose connections are tight before adding fluids ○ Check all electrical connections for securement and proper contact ○ Reconnect battery and do systems check before starting engine ○ After systems check is complete make sure all loose items are removed from the engine ○ Start engine and check status. 	<p>See Common Hazards Above</p> <p>Tipping Hazard, crushing hazards, Pinch Points, Hydraulic leaks, Damage to equipment, caught between, Moving Equipment, Fire Hazard, Falling objects, Hydraulic Oil Spills</p>	<p><i>See Safe Job Practices Above</i></p> <p>Communication, Keep hand out of the line of fire. Continues housekeeping to avoid tripping hazards All hoses should still be purged of liquid. Before installation Request site to assist with spill control/prevention. Flagger to continue to direct traffic away from the work area Gloves to be always worn for hands on work Continuous housekeeping to ensure area is clear of tripping hazards</p>
<ul style="list-style-type: none"> ● Clean up and Head out <ul style="list-style-type: none"> ○ Prep area for demob of assist crane or relocation. ○ Conduct a sweep of the area and preform Housekeeping on site ○ Remove barricades and leave the facility returning to the terminal. <p>NOTE: Do not leave any trash, tools or parts at the job site.</p>	<p>See Common Hazards Above</p> <p>Tipping Hazard, crushing hazards, Pinch Points, Hydraulic leaks, Damage to equipment, caught between, Moving Equipment, Fire Hazard, Falling objects, Hydraulic Oil Spills</p>	<p><i>See Safe Job Practices Above</i></p> <p>Communication Housekeeping and police area for any tools trash tripping hazards etc.. Communication with all employees Gloves to be always worn for hands on work Flagger for all equipment moving in the area Clear area before equipment is moved or positioned Ensure fire extinguisher is close and good working order With site advisement clean up and remove any spill or contaminated materials at sites recommendation Secure all tools and parts for transport.</p>

Job Safety Analysis

Use These Forms Before You Begin Any Job to Alert You of Any Hazards That May Exist

Engine Removal and Installation

Additional Comments (include any additional observations or comments on this job task below)

All personnel shall review the job safety analysis prior to work activity and sign below. Perimeter of work area shall have yellow caution or red warning tape installed to prevent any unnecessary jobsite personnel being exposed to these hazards.

PRINT

SIGNATURE

Assembly/Disassembly Director: _____ Date: _____