

RFSPICE is the most affordable RF circuit simulation tool in the market. Built upon the solid and mature B2.Spice A/D foundation, our popular analog, digital and mixed-mode circuit analysis tool, RF.Spice features an extensive library of RF devices that include S-parameter-based multiport networks and a variety of generic and physical transmission line types like microstrip, strip line, several CPW types, etc.

You can use RF.SPICE to simulate or design high-frequency, lumped and distributed, analog and mixed-mode circuits and analyze voltages and currents in both time and frequency domains. You can also compute the scattering parameters and other port characteristics of your network and plot them in Cartesian graphs or Smith charts. A large collection of virtual (black-box) blocks allow you to simulate various signal processing or system-level functions for rapid assessment

## FEATURES

- Streamlined user interface and quick schematic entry using a large set of keyboard shortcuts for generic parts and a versatile wiring tool
- More than 25,000 analog, digital and RF parts including hundreds of realistic behavioral models for resistors, inductors and capacitors
- A large selection of active device models (diode, BJTs, FETs, MOSFETs, MESFETs, operational amplifiers, etc.) with no less than six distinct MOSFET models including BSIM3 and BSIM4
- One-ports, two-ports, three-ports, four-ports, complex impedance, and other S-parameter-based devices
- Import high frequency models of capacitors, inductors, diodes, BJTs, JFETs, MOSFETs, MESFETs, from simple text files
- Ten types of physical transmission line models including microstrip, strip line, coplanar waveguide, coaxial lines, etc.
- A large variety of RF generic components such as Wilkinson power divider, branch line and rat-race hybrid couplers, as well as physical line discontinuity models

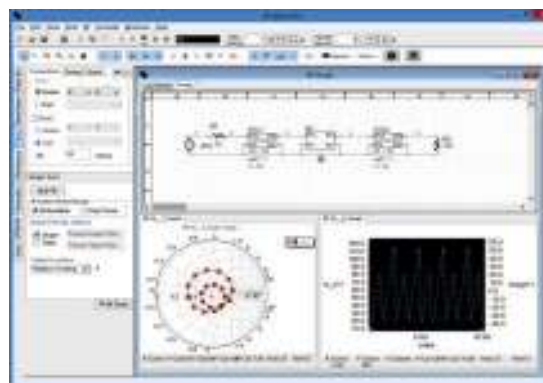

GUI of RFSPICE Software

## D/A CONVERTER CIRCUIT

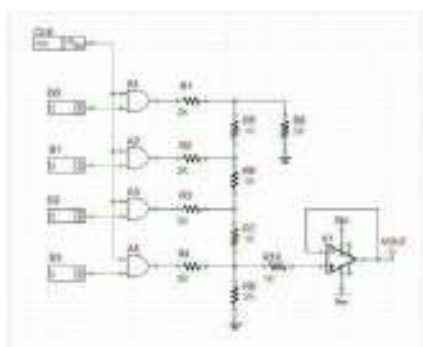

The R-2R Ladder D/A Converter circuit with Op-Amp

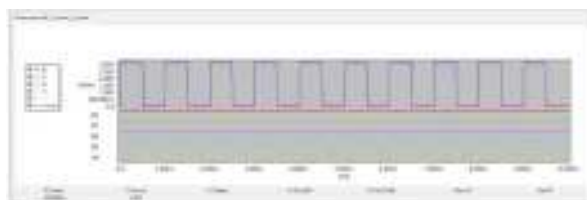

The Four digital inputs and the output analog voltage of the ladder D/A Converter When B3B2B1B0=1111

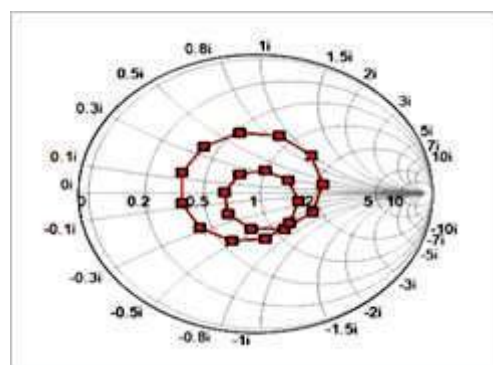

Smith Chart

## APPLICATIONS

- Analyze passive and active analog circuits involving RLC elements, diodes, transistors, operational amplifiers, integrated circuits, power devices, transformers, etc. either in real time or in frequency domain.
- Analyze digital circuits made of logic gates, flip flops, complex digital devices, etc. and probe them using live timing diagrams.
- Simulate RF circuits consisting of transmission line components, S-parameter-based multiport devices, distributed passive circuits, etc. and perform a network analysis on the Smith chart.
- Combine analog, digital and RF devices in mixed-signal circuits and perform mixed-mode simulations using A/D and D/A bridges