

Stella™

Managed HW1

Instructions and Notices

© 2025-2026 HABIT Robotics, Inc. All rights reserved. Stella™ and the Stella Logo are trademarks of HABIT Robotics, Inc. All other trademarks are the property of their respective owners. The Stella software and related firmware are proprietary to HABIT Robotics, Inc. Use of the Device and software is licensed, not sold, and subject to applicable agreements. **Important safety, usage, and legal information is provided at the end of this manual.**

This page is intentionally left blank.

Welcome to Stella's Beta Program.

Stella is excited to work for your business!

Stella greets customers, answers questions, and acts like a salesperson in conversations.

By hiring Stella in Beta, your business is now at the cutting edge of AI. Throughout and after the Beta, Stella will receive frequent remote updates.

On behalf of our California team, **thank you for hiring Stella**. We hope she is an effective addition to your team!



MICHAEL TREHAN
Chief Executive Officer

HARISH PALANI
Chief Technology Officer

Getting started.

Watching a **video** may make everything easier.

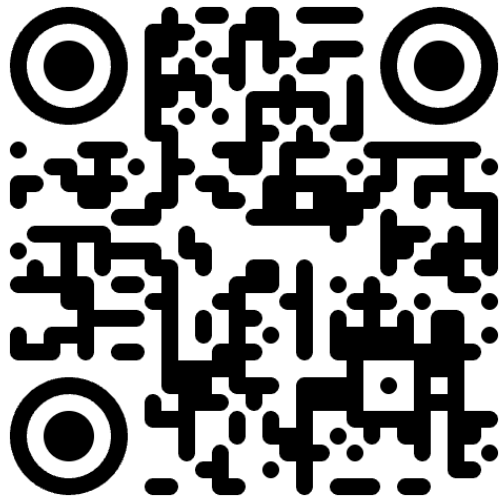
Visit **stellabots.com/unboxing** – or scan this QR code:



You have **Hardware Version: Managed HW1**.

Need assistance? Our California team is ready to help.
Log in to your **stellabots.com** account to submit a ticket.

Important safety, usage, and legal information is provided at the end of this manual.

Keep her box.

Stella (Managed HW1) is **leased** to you.

Keep the box and packaging materials somewhere safe – this is now your **lease return box**.

If Stella needs to find employment elsewhere, we will provide a free return label¹ – but not packaging.

¹ Return shipping is free – but ending your lease early may incur a separate fee. Please refer to your lease agreement for specifics.

What's in her box?

 <p>Spine (3x)</p>	 <p>Spine Front Cover (3x)</p>	 <p>Spine Back Cover (4x)</p>
 <p>Wheel (4x)</p>	 <p>Electronics Module</p>	 <p>Security Plate</p>
 <p>Top Cap</p>	 <p>Tablet Module</p>	 <p>Tablet Cable Cover</p>
 <p>Monitor Module</p>	 <p>Monitor Top Cover</p>	 <p>Base (1x) & Jugs (2x)</p>
 <p>Base Front Cover</p>	 <p>Base Back Cover</p>	 <p>Screw (18x)</p>
 <p>M4 Screw</p>	 <p>Spare Nuts</p>	 <p>Wrench (may vary)</p>

Step 1: What does she need?

Assembling Stella (Managed, HW1) takes ~**45 minutes**.

You need:

- A sink (to fill the base weights).
- A place to plug her in and secure her.
- Wi-Fi.

Now, unbox her:

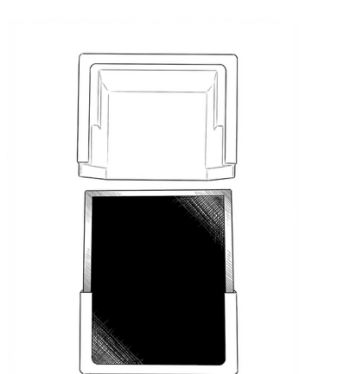

A: Remove the top cover from the monitor.

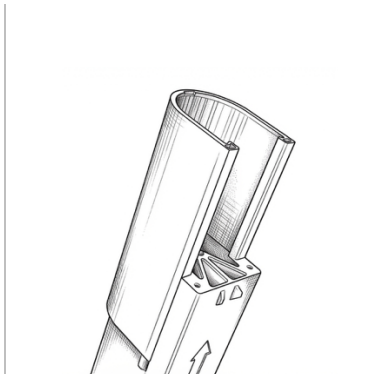

B: Slide the front covers off the 3 spine pieces.

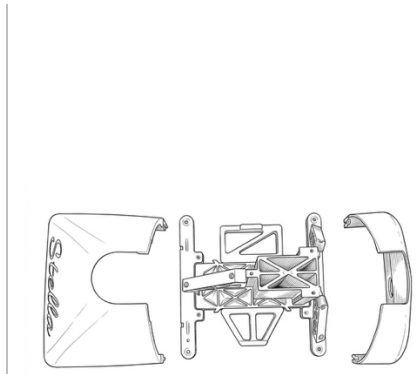

C: Vertically pull the front and back covers up off the base.

Step 2: Assemble her spine.

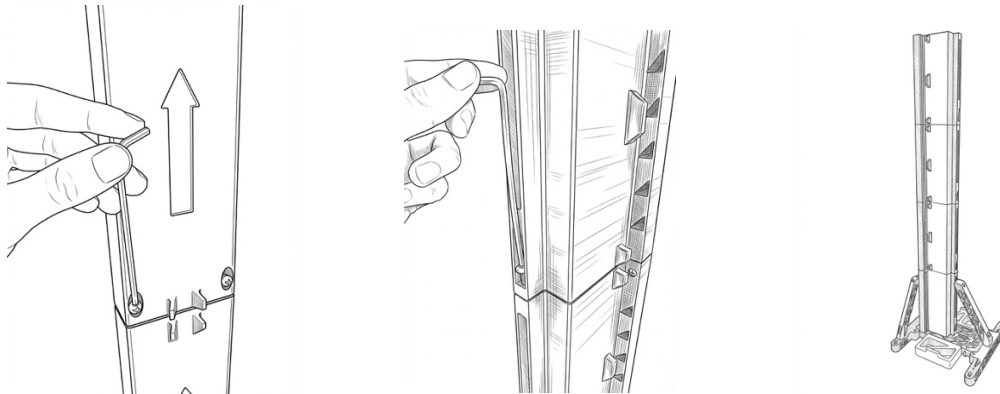

A: Attach the 3 spine pieces. Then, attach them to the base. To attach pieces, use 3 screws as shown. Hand-tighten with wrench.

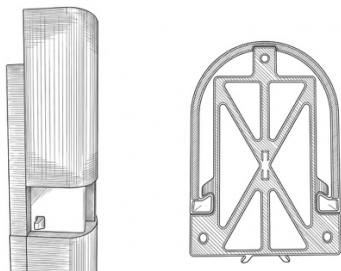

B: Slide 3 spine front covers down vertically. Ensure they are flush.

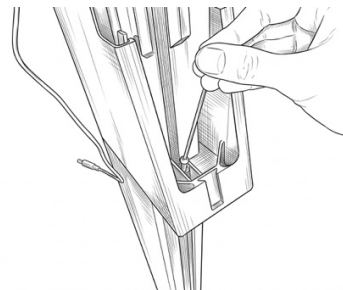

C: Attach the electronics module with 3 screws (front screw shown).

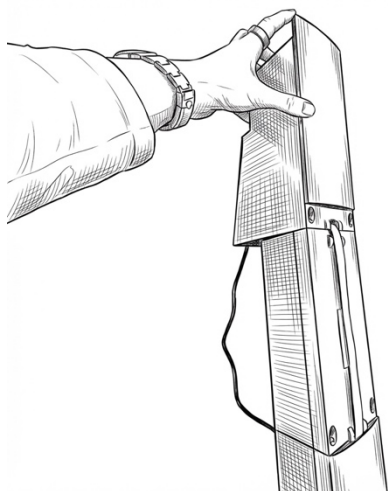

D: Run the power cord down the center of the rear of the spine. Then, slide 4 spine back covers down vertically over the cord.

Keep them close to the spine when sliding, or they may fall out.

Step 3: Assemble her base.

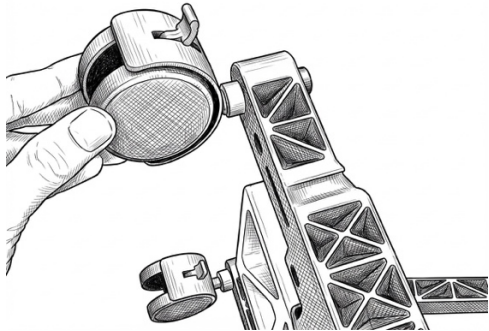

A: Turn sideways. Then, press 4 wheels straight into the base.

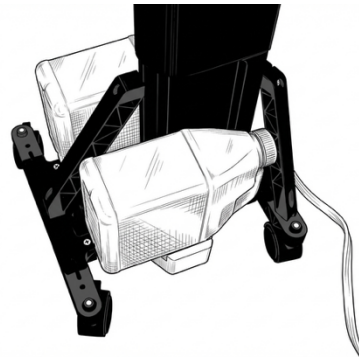

B: Fill 2 jugs with water. Lay them cap-side-up on the base as shown.

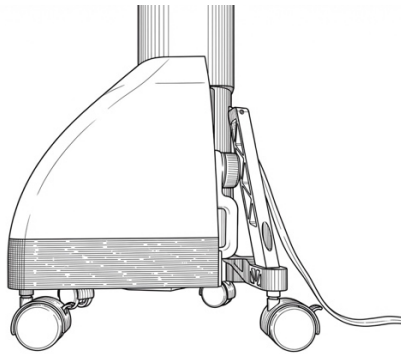

C: Vertically slide the front base cover down. It seats into grooves at the front of the base.

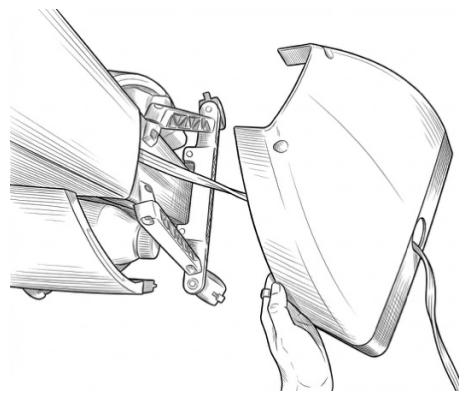

D: Insert the power cord through the back cover.

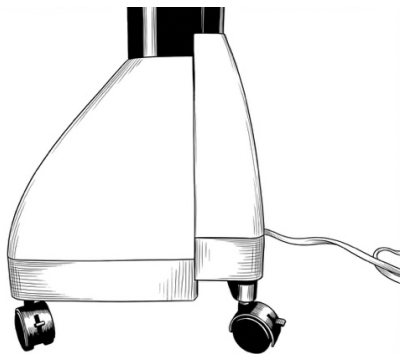

E: Vertically slide the back base cover down. It seats into grooves at the back of the base.

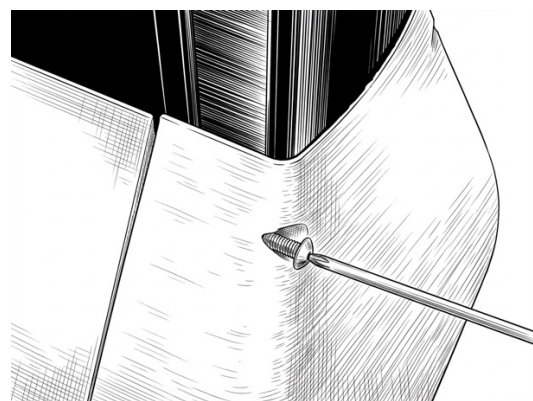

F: Use 2 screws to connect the front and back covers together.

Step 4: Attach the tablet.

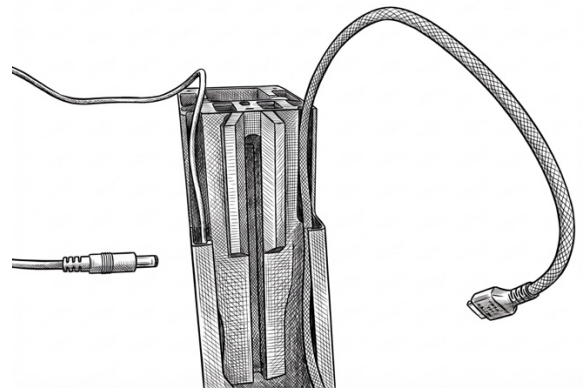
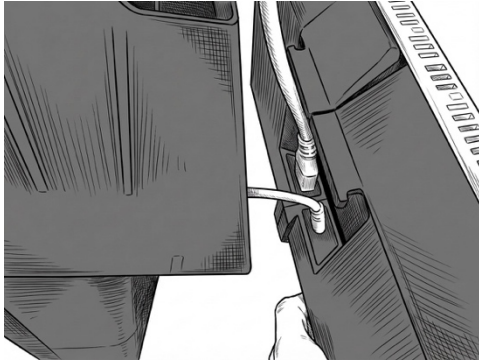

A: Attach the HDMI and USB-C cable to the rear of the tablet. Hold the tablet by the electronics unit, since cables are short. The other end of the HDMI cable and the DC cable should remain free (as shown) and routed through the channels on the electronics unit.

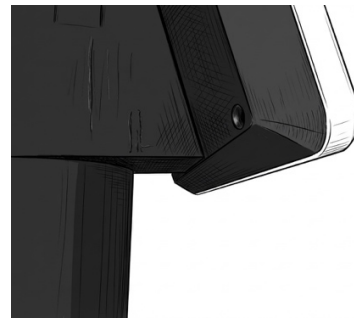
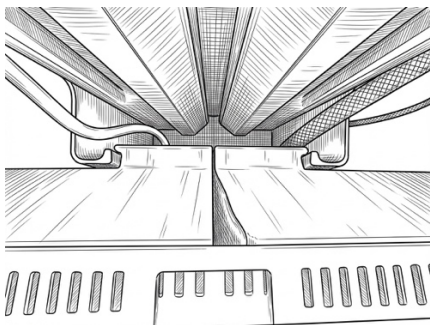

B: Slide the tablet into the lower grooves of the electronics unit. Make sure the DC and HDMI cables are routed as shown and aren't pinched. Make sure the top part of the tablet connector is seated correctly.

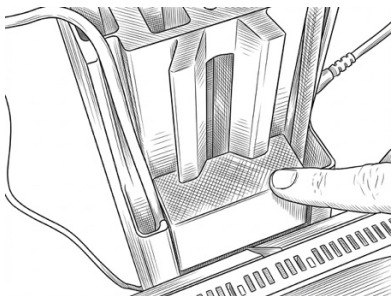

C: Slide the tablet cable cover down on the upper grooves of the electronics unit.

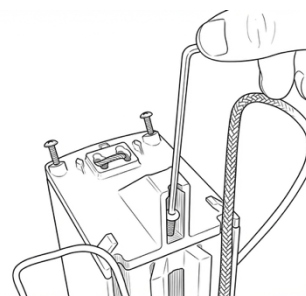

D: Attach the security plate on top of the elec. unit with 3 screws. Ensure front is flush with elec. unit.

Step 5: Attach the monitor.

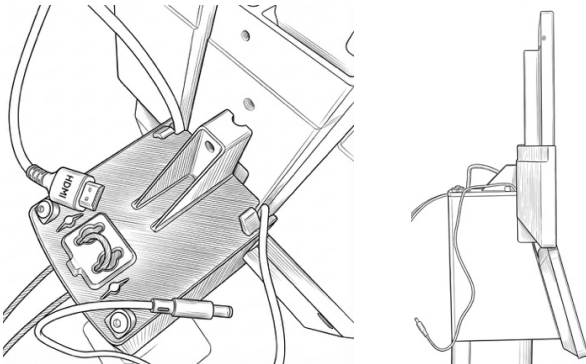

A: Slide monitor vertically down onto upper grooves of elec. unit, with both cables in channels.

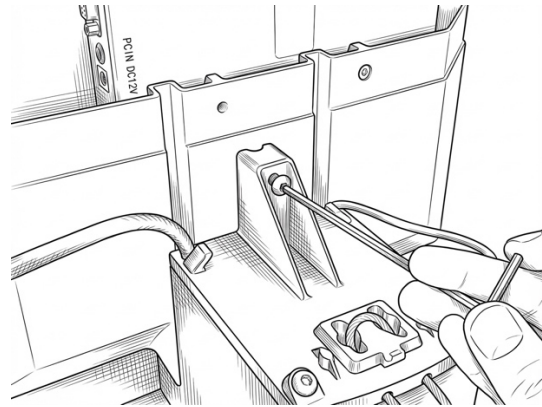

B: Use 1 screw to attach the monitor to the security plate.

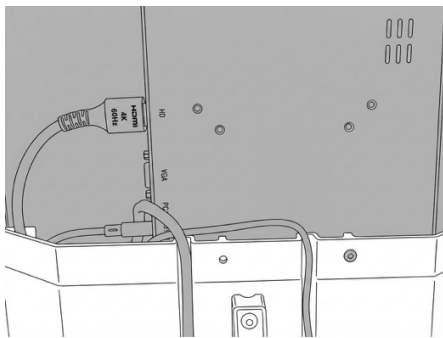

C: Connect the HDMI and DC cables to the monitor. Press into channels and loop excess length into the monitor so they're flush.

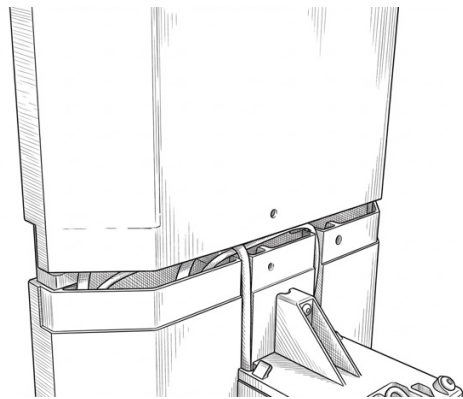

D: Slide the top monitor cover vertically down onto the monitor. Ensure cables aren't pinched.

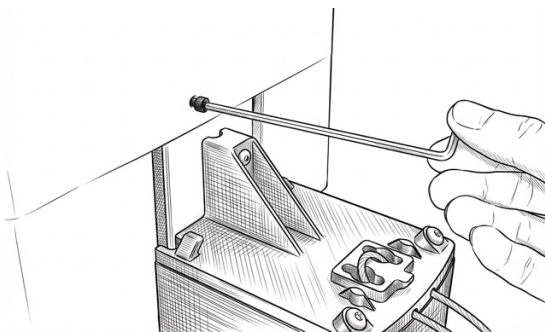

E: Secure top monitor cover with the **M4 screw**.

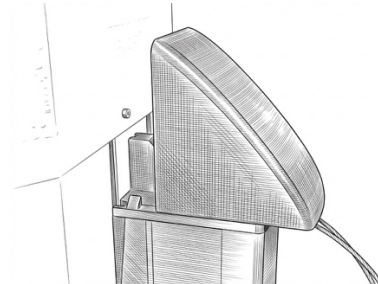

F: Store tools (not depicted) in top cap. Then, slide cap horizontally onto the security plate.

Step 6: Cleanup and Safety

A. Save these instructions and spare parts in the box.

B. Secure to a fixed object with the security cable!

Next: Train her.

Once plugged in, let Stella start up. **This process may take a while.** Do not worry if you see an app launcher screen. Eventually, the Stella program will launch.

To connect Stella to Wi-Fi and continue setup, visit stellabots.com/setup – or scan the QR code below:

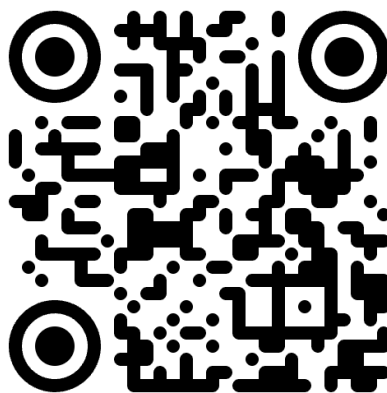

Troubleshooting

If Stella's tablet or monitor modules do not turn on:

1. Check outlet; unplug Stella and plug her back in.
2. Check that the USB-C and HDMI cables are connected to the tablet properly.
3. Check that the DC monitor jack and HDMI cable are **fully** inserted into Stella's top screen.
4. Check that the two power bricks are seated to the power strip inside the electronics unit.
5. Press the tablet's power button with a flathead.
6. Press the power button on the top rear of the monitor. It may have accidentally been turned off.
7. Check that the wiring inside the tablet unit is correct (may require disassembly).
8. Check the cables for any damage.

Visit stellabots.com/support for more troubleshooting.

Need assistance? Our California team is ready to help.

Log in to your stellabots.com account to submit a ticket.

Safety and Legal

WARNING

It is your responsibility to **always** secure Stella to a wall or fixed mount using the included retention cable to avoid tip-overs, which may result in injury or death.

REMINDER

It is your responsibility to ensure that your placement and usage of Stella comply with all regulations, including, but not limited to, the Americans with Disabilities Act of 1990.

USAGE

Stella is for indoor use only. Keep liquids away. Do not climb, sit on, lean on, or hang objects from Stella.

Important: Please read this section carefully. It contains important safety, usage, and legal information that applies to your use of the Stella™ device (“Stella”). Additional binding terms apply under your separate lease and subscription agreement.

1. Intended Use

Stella™ is a stationary, indoor AI kiosk designed to provide informational, conversational, and promotional interactions in public commercial environments.

Stella:

- Is not mobile
- Is not a safety, security, or monitoring system
- Does not replace employees, attendants, or emergency systems
- Is intended solely for informational and customer-engagement purposes

Stella must be used only as described in this manual and in accordance with all applicable laws and agreements.

2. General Safety Information

To reduce the risk of injury, damage, or malfunction:

- Indoor use only. Do not expose Stella to rain, moisture, or outdoor conditions unless explicitly rated for such use.
- Do not climb, sit on, lean on, or hang objects from Stella.
- Do not block ventilation openings.
- Keep liquids away from the device and power connections.
- Do not open, disassemble, or modify any part of the device.
- Supervise children. Stella is not a toy.
- Use only approved mounting methods and hardware as described in the installation instructions.

Failure to follow these guidelines may result in damage, injury, or service interruption.

3. Electrical Safety

- Connect Stella only to a properly grounded power outlet.
- Do not use damaged power cords, adapters, or outlets.
- Do not overload circuits.
- If Stella appears damaged, emits unusual odors, or behaves abnormally, disconnect power immediately and contact support.

4. Placement and Stability

You are responsible for ensuring Stella is:

- Securely mounted or placed on a stable surface
- Installed in a location where it cannot be easily tipped, struck, or obstruct emergency paths
- Positioned away from high-traffic collision risks and wet areas

Improper placement may create a hazard and may constitute misuse.

5. Cameras, Microphones, and Recording Notice

Stella includes cameras, microphones, and other sensors required for intended operation.

Depending on configuration, Stella may:

- Capture audio and/or video in publicly accessible areas
- Perform automated processing and analysis of interactions

You are solely responsible for:

- Only placing Stella in areas where recording the public is permitted

- Complying with all applicable privacy, surveillance, employment, and consumer-protection laws
- If applicable, posting clear and legally required signage notifying customers and employees that recording and automated processing may occur
- Obtaining and maintaining any required consents

Stella Bots does not provide legal advice regarding compliance obligations.

6. Acceptable Environment

Operate Stella only within supported conditions, including:

- Publicly accessible, commercial indoor environments (e.g., retail floors, lobbies, reception areas)
- Normal ambient temperature and humidity ranges
- Adequate lighting and network connectivity

Do not deploy Stella in environments involving:

- Water exposure
- Excessive heat, dust, or vibration
- Hazardous or regulated industrial settings
- Life-safety or emergency-response use cases

7. Software, Connectivity, and Remote Access

Stella operates using cloud-based software and services.

By using Stella, you acknowledge that:

- Software updates, patches, and configuration changes may be applied automatically
- Stella Bots may remotely monitor device health, connectivity, and performance
- Remote access may be used for diagnostics, maintenance, safety, abuse prevention, and product improvement

Service availability depends on power, network connectivity, and external systems.

8. No Reliance; Informational Use Only

Stella's responses and outputs:

- Are provided for general informational and promotional purposes only
- May be considered offensive, incomplete, inaccurate, or outdated
- Must not be relied upon for legal, medical, safety, employment, financial, or regulatory decisions

You remain responsible for verifying information and supervising customer interactions as appropriate.

9. Damage, Misuse, and Responsibility

You are responsible for safeguarding the device from:

- Theft
- Vandalism
- Abuse
- Unauthorized modification
- Improper relocation or installation

Damage beyond normal wear, loss, or failure to return the device may result in replacement or repair charges as outlined in your separate lease and subscription agreement.

10. No Warranty; No Service-Level Guarantee

Stella™ and all associated software and services are provided “as is” and “as available.”

To the fullest extent permitted by law:

- No express or implied warranties are provided
- No uptime, availability, or performance guarantees are made

Your rights and remedies, if any, are governed solely by your separate written agreement with Stella Bots.

11. Limitation of Liability

To the maximum extent permitted by applicable law, Stella Bots is not responsible for:

- Indirect, incidental, special, consequential, or punitive damages
- Lost profits, lost data, or business interruption
- Injuries or damages resulting from misuse, improper installation, or failure to follow instructions

Additional liability limitations apply under your lease and subscription agreement.

12. Governing Terms and Agreement Priority

Your use of Stella is governed by a separate Terms of Service and Lease Agreement provided at the time of ordering or available through your account.

If there is any inconsistency between this manual and your executed agreement:

- The agreement controls
- This manual does not modify or replace any contractual obligations.

13. Support and Contact

For questions, support, or safety concerns, contact:

Stella Bots

support@stellabots.com