



MIXA II

User Manual

TABLE OF CONTENTS

- | | |
|----|--|
| 01 | Acknowledgments
Appreciation and warm welcome to the BAT family. |
| 03 | What's in the Box?
A quick overview of all items included in the package. |
| 04 | Key Features
Highlights of the main functions and benefits. |
| 05 | Specs Sheet
Detailed technical specifications of the product. |
| 06 | Dimensions
Physical measurements and size details. |
| 07 | Front Panel
Overview of buttons, indicators, and controls on the device's front. |
| 08 | Rear Panel
Overview of ports and controls on the back of the device. |
| 09 | Connection Guide
Visual guide for wiring and setup connections. |
| 12 | Hazard/Warning Note
Important safety cautions and potential risks. |
| 13 | Warranty/Disclaimer
Coverage terms and conditions for product support. |

Acknowledgments

EN

Thank you for choosing BAT.

Your trust in our commitment to sonic precision and purposeful design means the world to us. Each BAT product is the result of rigorous engineering, careful craftsmanship, and a relentless pursuit of acoustic clarity. We hope it brings richness and reliability to every sound you experience. Welcome to the BAT family.

FR

Merci d'avoir choisi BAT.

Votre confiance en notre engagement envers la précision sonore et le design réfléchi nous touche profondément. Chaque produit BAT est le fruit d'une ingénierie rigoureuse, d'un artisanat soigné et d'une quête incessante de clarté acoustique. Nous espérons qu'il apportera richesse et fiabilité à chaque son que vous vivrez. Bienvenue dans la famille BAT.

DE

Vielen Dank, dass Sie sich für BAT entschieden haben.

Ihr Vertrauen in unser Engagement für klangliche Präzision und durchdachtes Design bedeutet uns sehr viel. Jedes BAT-Produkt ist das Ergebnis rigoroser Ingenieurskunst, sorgfältiger Handwerkskunst und eines unermüdlichen Strebens nach akustischer Klarheit. Wir hoffen, dass es jedem Ihrer Klangerlebnisse Reichtum und Zuverlässigkeit verleiht. Willkommen in der BAT-Familie.

IT

Grazie per aver scelto BAT.

La sua fiducia nel nostro impegno per la precisione sonora e il design mirato è per noi di grande valore. Ogni prodotto BAT è il risultato di un'ingegneria rigorosa, di una lavorazione artigianale accurata e di una costante ricerca della chiarezza acustica. Ci auguriamo che porti ricchezza e affidabilità a ogni suono che ascolta. Benvenuto nella famiglia BAT.

JP

BAT をお選びいただきありがとうございます。

音の精度と意図的なデザインへの私たちの取り組みに対するあなたの信頼は、私たちにとって非常に重要です。BAT の各製品は、厳密なエンジニアリング、丁寧なクラフトマンシップ、そして音響の明瞭さへの絶え間ない追求の成果です。

それがあなたのすべての音の体験に豊かさや信頼性をもたらすことを願っています。BAT ファミリーへようこそ。

AR

شكرًا لاختيارك BAT.

إن ثقتك في التزامنا بالدقة الصوتية والتصميم المدروس تعني لنا الكثير. كل منتج من BAT هو نتيجة لهندسة دقيقة، وحرفية متقنة، وسعي لا يكل لتحقيق وضوح صوتي فائق. نأمل أن يضيف هذا المنتج ثراءً وموثوقية لكل تجربة استماع تخوضها. مرحبًا بك في عائلة BAT.

Acknowledgments

SP

Gracias por elegir BAT.

Su confianza en nuestro compromiso con la precisión sonora y el diseño intencionado significa mucho para nosotros. Cada producto de BAT es el resultado de una ingeniería rigurosa, una artesanía cuidadosa y una búsqueda incansable de claridad acústica. esperamos que aporte riqueza y fiabilidad a cada sonido que experimente. Bienvenido a la familia BAT.

RU

Благодарим вас за выбор BAT.

Ваше доверие к нашему стремлению к звуковой точности и продуманному дизайну очень важно для нас. Каждый продукт BAT результат строгой инженерии, тщательного мастерства и неустанного стремления к акустической ясности.

Мы надеемся, что он принесет богатство и надежность в каждое ваше звуковое впечатление. Добро пожаловать в семью BAT.

CN

感谢您 BAT。

您我在声音精度和有目的方面承的信任我意重大。每一款 BAT 品都是工程、精心工和音响清晰度不懈追求的晶。

我希望它能您的每一次聆听体来丰富和可靠。迎加入 BAT 大家庭。

PT

Obrigado por escolher a BAT.

A sua confiança no nosso compromisso com a precisão sonora e o design intencional significa muito para nós. Cada produto BAT é o resultado de engenharia rigorosa, artesanato cuidadoso e uma busca incessante pela clareza acústica.

Esperamos que ele traga riqueza e confiabilidade a cada som que você experimente. Bem-vindo à família BAT.

TR

BAT'ı seçtiğiniz için teşekkür ederiz.

Ses hassasiyeti ve amaçlı tasarıma olan bağlılığımıza duyduğunuz güven bizim için çok değerlidir. Her BAT ürünü, titiz mühendislik, özenli işçilik ve akustik netliğe yönelik amansız bir arayışın sonucudur.

Bu ürünün, yaşadığınız her ses deneyimine zenginlik ve güvenilirlik katmasını umuyoruz. BAT ailesine hoş geldiniz.

HI

BAT चुनने के लिए धन्यवाद।

ध्वनि की सटीकता और उद्देश्यपूर्ण डिज़ाइन के प्रति हमारी प्रतिबद्धता में आपके विश्वास का हमारे लिए बहुत महत्व है। प्रत्येक BAT उत्पाद कठोर इंजीनियरिंग, सावधानीपूर्वक शिल्प कौशल और ध्वनिक स्पष्टता की निरंतर खोज का परिणाम है।

हमें आशा है कि यह आपके हर श्रवण अनुभव में समृद्धि और विश्वसनीयता लाएगा। BAT परिवार में आपका स्वागत है।

What's in the Box?



User Manual



Remote Control

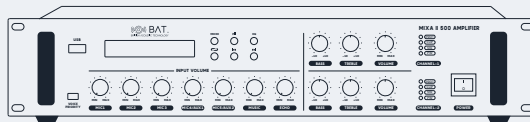

Your BAT MIXA II Amplifier



Power Cable



Audio Cable

Key Features

MIXA II Series



Power, Clarity, Total Control.

The MIXA II series is a professional-grade 2-channel mixing amplifier solution designed for versatile commercial audio applications. Delivering up to 250W or 500W per channel, these amplifiers offer flexible output for 70/100V or low-impedance speaker systems, all in a compact 2U rack-mountable design. Ideal for restaurants, conference halls, and public venues, the MIXA II Series combines media playback, microphone handling, and precise audio control in one powerful unit.

Advanced Audio, Effortlessly Delivered.

The MIXA II series utilizes Class D amplifier technology for powerful output with low energy consumption and heat. Each channel includes independent bass, treble, and volume controls, while the built-in media player supports Bluetooth, USB, and AUX with a clear status display. Five microphone inputs are available, including 48V phantom power on three and voice priority on Mic1.

Dependable Power, Every Time.

Built for reliability, the series offers full protection against short circuit, overload, over-voltage, and overheating. LED level indicators and a line output ensure easy monitoring and system expansion, making the MIXA II series a dependable solution for commercial audio installations.

Specs Sheet

Unit	MIXA II 250	MIXA II 500
Rated Power:	2 x 250W	2 x 500W
Amplifier System:	Class D, 90% Efficient (2 Channels)	
Voltage Line Output:	70V-100V	
Low Impedance Output:	4Ω & 8Ω	
Frequency Response:	60 Hz~15 kHz (±3 dB)	
T.H.D:	< 1% @ 1kHz, 1/3 Rated Power	
S/N Ratio:	≥75dB	
Tone Control:	Bass: 100 Hz (±10 dB), Treble: 10 kHz (±10 dB)	
Media Source Options:	Bluetooth, U-disk, AUX	
Aux Input:	Unbalanced R&L (RCA) x 2	
Line Output:	Unbalanced R&L (RCA) x 1	
Mic Inputs:	Mic1—Mic3: XLR & 6.35mm (48V Phantom) Mic4—Mic5: 6.35mm	
Voice Priority:	Mic1	
Output Level Meter:	Power, Signal, Clip, Protection	
Protection:	Short Circuit, Overload, Over-Voltage, High Temperature	
Power Supply:	AC 110—240V, 50/60Hz	

Specs Sheet

Unit	MIXA II 250	MIXA II 500
AC Fuse:	T4A	T8A
Power Consumption:	600W	1200W
Power Cord:	(3 x 0.75 mm ²) x 1.5m	
Chassis:	2U Rack-Mount, With Handles & Mounting Ears	
Dimension (DxWxH):	350x483x89mm	
Carton Size (DxWxH):	435x520x185mm	
Net Weight:	9.00kg	10.5Kg
Gross Weight:	10.50kg	12.5Kg

Dimensions

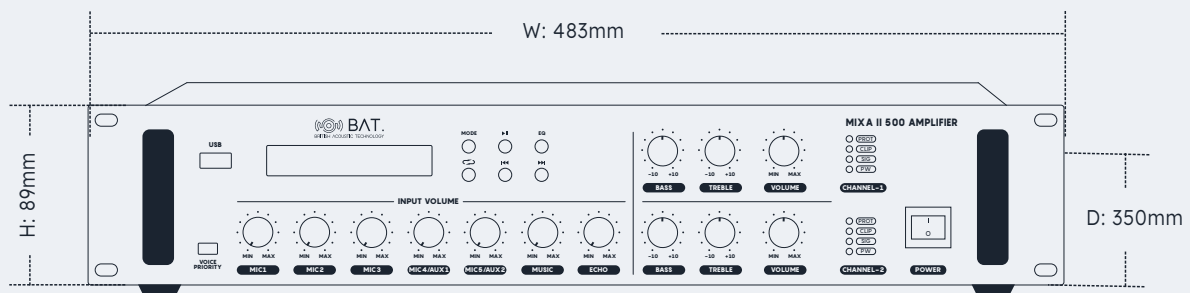

Front Panel

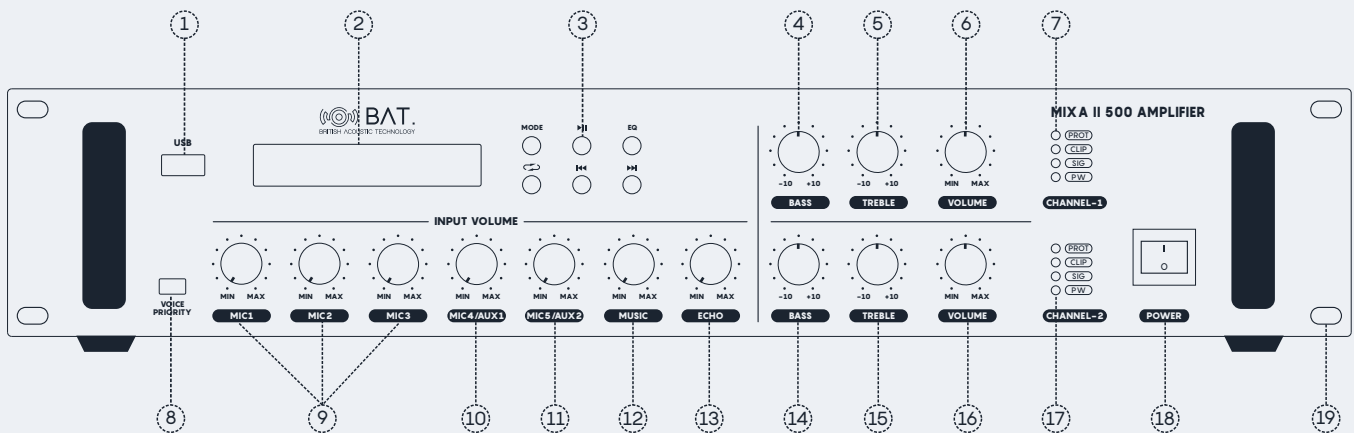

1. **USB Port** – Supports audio playback from a USB flash drive.
2. **Display Screen** – Shows the current operating status and media playback information.
3. **Media Source Controls**
 - **MODE:** Switches between USB and Bluetooth modes.
 - **Play/Pause:** Press to pause playback; press again to resume.
 - **EQ:** Selects from four equalizer presets (available in USB mode).
 - **REPEAT:** Toggles between repeat one, repeat all, and shuffle playback.
 - **PREV:** Press to go to the previous track; press and hold to decrease media volume.
 - **NEXT:** Press to skip to the next track; press and hold to increase media volume.
4. **Bass Control (Channel 1)** – Adjusts the low-frequency response for Channel 1.
5. **Treble Control (Channel 1)** – Adjusts the high-frequency response for Channel 1.
6. **Volume Control (Channel 1)** – Controls the output volume of Channel 1.
7. **LED Level Meters (Channel 1)** – Indicates the output signal level of Channel 1.
8. **Voice Priority (MIC 1)** – Enables the Auto-Mute function, automatically lowering the music volume when MIC 1 is active.
9. **Microphone Volume Controls (MIC 1, MIC 2, MIC 3)** – Individually adjust the volume levels for MIC 1, MIC 2, and MIC 3 inputs.
10. **MIC 4 / AUX 1 Volume Control** – Adjusts the volume for either the MIC 4 or AUX 1 input.
11. **MIC 5 / AUX 2 Volume Control** – Adjusts the volume for either the MIC 5 or AUX 2 input.
12. **Music Volume Control** – Adjusts the playback volume of media from USB or Bluetooth.
13. **Echo Control** – Adjusts the echo effect applied to microphone inputs.
14. **Bass Control (Channel 2)** – Adjusts the low-frequency response for Channel 2.
15. **Treble Control (Channel 2)** – Adjusts the high-frequency response for Channel 2.
16. **Volume Control (Channel 2)** – Controls the output volume of Channel 2.
17. **LED Level Meters (Channel 2)** – Indicates the output signal level of Channel 2.
18. **Power Switch (ON/OFF)** – Turn the unit on or off.
19. **Rack Mounting Holes** – Allows the unit to be installed in a standard 19-inch equipment rack.

Rear Panel

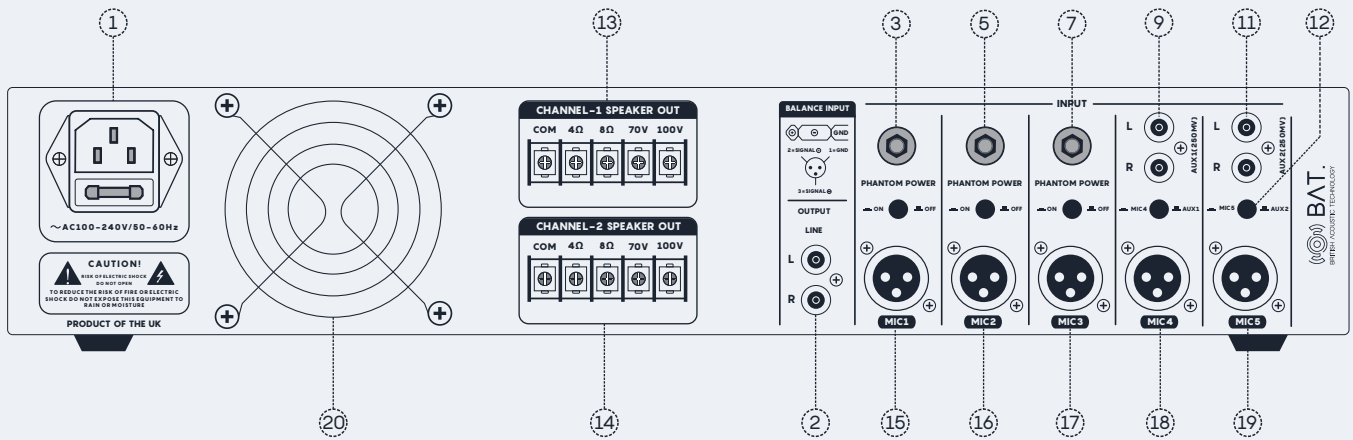

1. AC Power Inlet - Connect the included 3-pin power cord here.
2. Line Outputs - Provides audio signals to two additional amplifiers simultaneously.
3. MIC1 Jack (6.35mm) - Accepts a standard 6.35mm microphone plug.
4. Phantom Power Switch (MIC1) - Press to enable or disable 48V phantom power for MIC1.
5. MIC2 Jack (6.35mm) - Accepts a standard 6.35mm microphone plug.
6. Phantom Power Switch (MIC2) - Press to enable or disable 48V phantom power for MIC2.
7. MIC3 Jack (6.35mm) - Accepts a standard 6.35mm microphone plug.
8. Phantom Power Switch (MIC3) - Press to enable or disable 48V phantom power for MIC3.
9. AUX1 Input (RCA) - Accepts stereo RCA input (L & R), internally summed to mono.
10. MIC4/AUX1 Selector Switch - Switches input between MIC4 and AUX1.
11. AUX2 Input (RCA) - Accepts stereo RCA input (L & R), internally summed to mono.
12. MIC5/AUX2 Selector Switch - Switches input between MIC5 and AUX2.
13. Output Terminals - Channel One - Refer to pages 7 and 9 for wiring details.
14. Output Terminals - Channel Two - Refer to pages 7 and 9 for wiring details.
15. MIC1 Jack (XLR Balanced) - Accepts a balanced XLR microphone connection.
16. MIC2 Jack (XLR Balanced) - Accepts a balanced XLR microphone connection.
17. MIC3 Jack (XLR Balanced) - Accepts a balanced XLR microphone connection.
18. MIC4 Jack (XLR Balanced) - Accepts a balanced XLR microphone connection.
19. MIC5 Jack (XLR Balanced) - Accepts a balanced XLR microphone connection.
20. Ventilation Outlet - Ensures proper airflow and cooling of the unit.

Remote Control

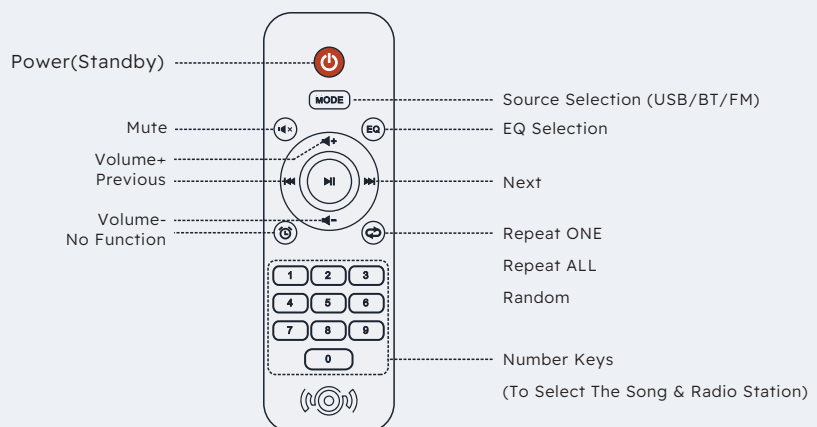

Connection Guide

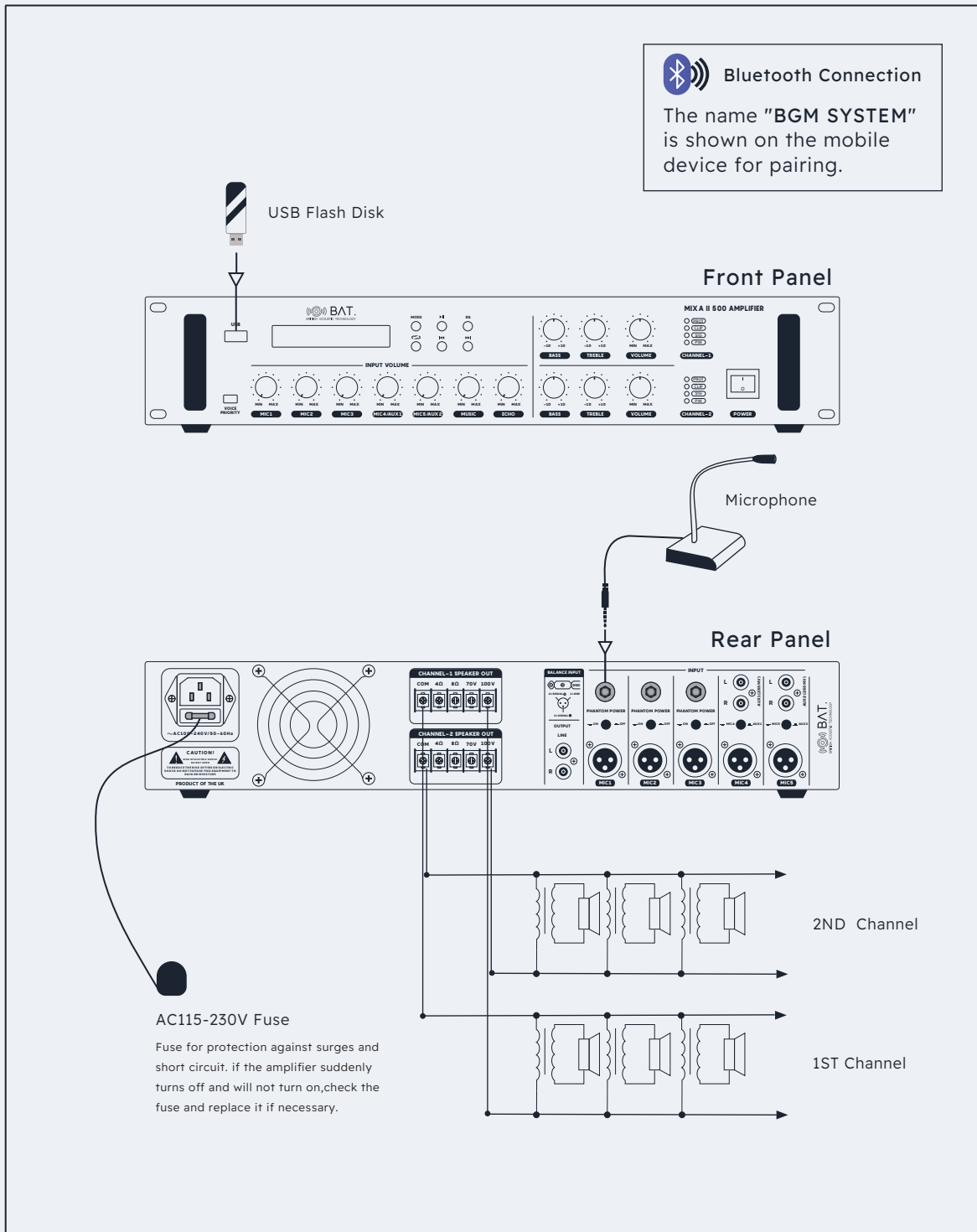

Connection Guide

This amplifier has multiple loudspeaker outputs, including 100V, 70V, and low impedance (4-8Ω).

100V Line Output

Use only 100V line loudspeakers with transformers, connected in parallel. Ensure the total load does not exceed the amplifier's rated output, and limit usage to 70% of rated power for optimal performance with music sources.

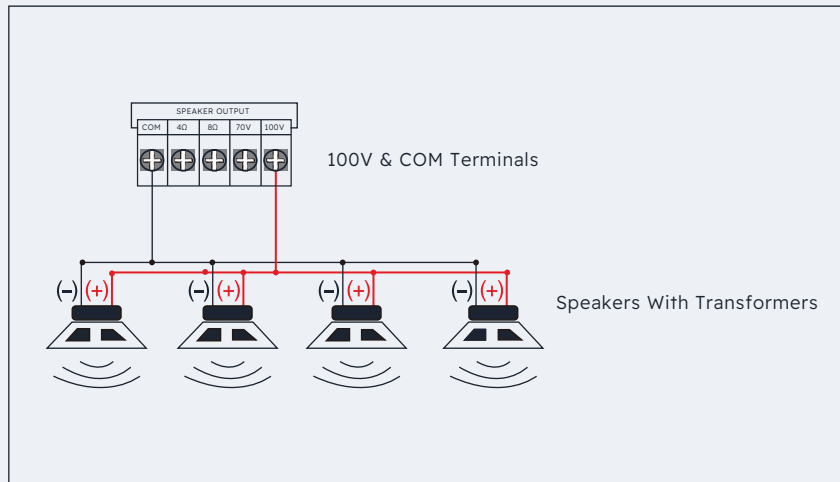

70V Line Output

This system, commonly used in the USA, operates on the same principles as a 100V line system, but delivers 70V RMS at the amplifier's output terminals when operating at rated power.

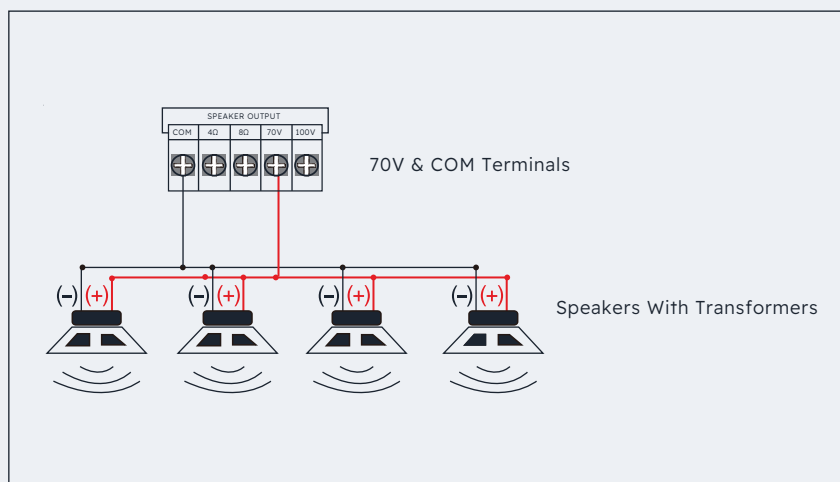



Connection Guide

4-8Ω Low Impedance Output

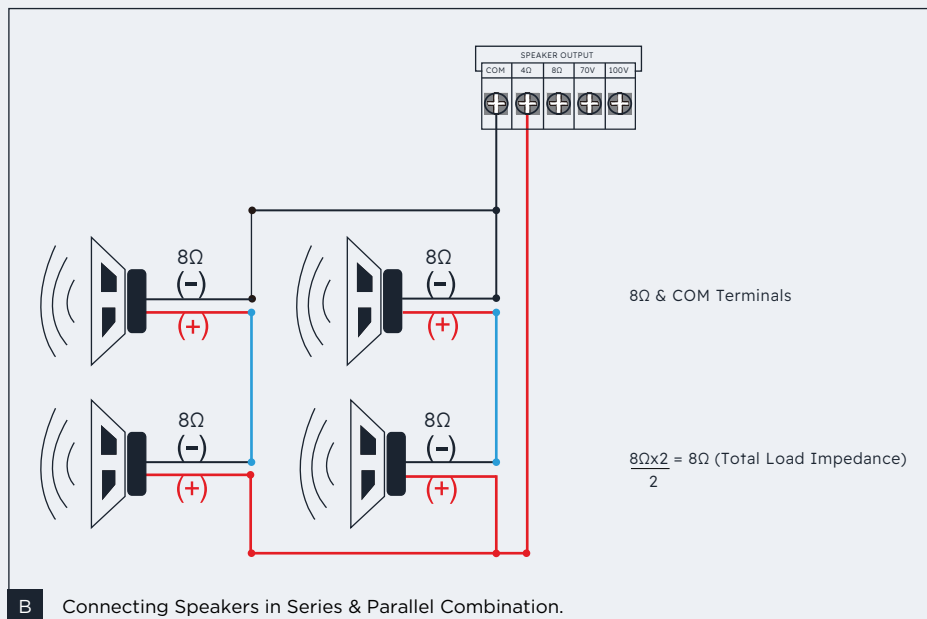
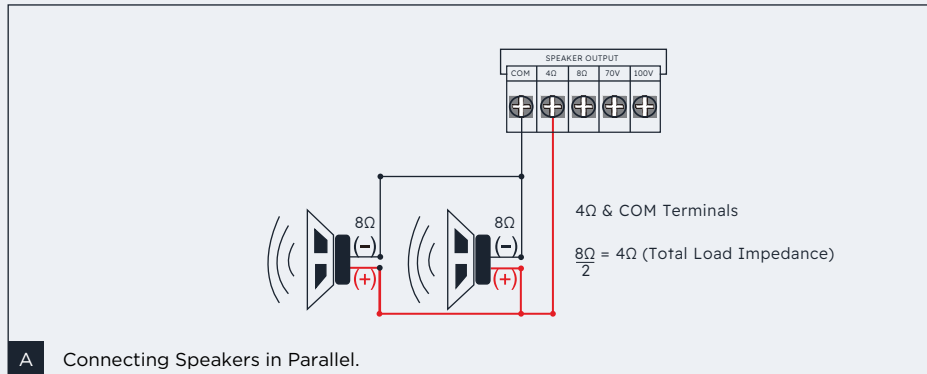
This output allows the connection of low-impedance loudspeakers without the need for transformers. When using multiple loudspeakers, ensure they are wired in series, parallel, or a series-parallel combination so that the total load impedance remains between 4Ω and 8Ω.



Hazard/Warning Note

	<p>The exclamation mark in an equilateral triangle alerts users to important safety instructions in the user manual. Please read carefully.</p>	
<p>1. Read these instructions. 2. Keep these instructions. 3. Heed all warnings. 4. Follow all instructions. 5. Do not use this apparatus near water. 6. Clean only with a dry cloth. 7. Do not block any ventilation openings. Install in accordance with the manufacturer's instructions. 8. Do not install near any heat sources such as radiators, heat registers, stoves, or other apparatus (including amplifiers) that produce heat. 9. Do not defeat the safety purpose of the polarized or grounding-type plug. A polarized plug has two blades with one wider than the other. A grounding type plug has two blades and a third grounding prong. The wide blade or the third prong are provided for your safety. If the provided plug does not fit into your outlet, consult an electrician for replacement of the obsolete outlet. 10. Protect the power cord from being walked on or pinched, particularly at plugs, convenience receptacles, and the point where they exit from the apparatus.</p> 	<p>11. Only use attachments/accessories specified by BAT. 12. Use only with the cart, stand, tripod, bracket, or table specified by the manufacturer, or sold with the apparatus. When a cart is used, use caution when moving the cart/apparatus combination to avoid injury from tip-over. 13. Unplug this apparatus during lightning storms or when unused for long periods of time. 14. Refer all servicing to qualified service personnel. Servicing is required when the apparatus has been damaged in any way, such as power-supply cord or plug is damaged, liquid has been spilled or objects have fallen into the apparatus, the apparatus has been exposed to rain or moisture, does not operate normally, or has been dropped. 15. Never introduce objects into the vents of the device. Doing so may contact high-voltage components or cause a short circuit, leading to fire or electric shock. Keep liquids away from the device. 16. Do not attempt to repair this device yourself. Opening the device can expose you to high voltages and other risks. For all</p>	<p>maintenance or repairs, contact qualified professionals. 17. Replacement Components: When replacement parts are required, be sure the service technician uses replacement parts specified by the manufacturer or have the same characteristics as the original part. Unauthorized substitutions may result in fire, electric shock, or other hazards. 18. Safety Check: Upon completion of any service or repairs to this device, ask the service technician to perform safety checks to determine that the device is in proper operating condition. 19. This appliance shall not be exposed to dripping or splashing water and that no object filled with liquids, such as vases, shall be placed on the apparatus. 20. In order to avoid damaging your hearing, do not listen to loudspeakers at high volumes for extended periods. Listening to speakers at high volumes can damage the user's ears and may lead to hearing problems. 21. Exposure to excessive volumes (over 85dB) for more than one hour can cause irreparable damage to your hearing.</p> 

Warranty

Your **BAT Amplifier** is accompanied by a separate warranty document outlining the specific terms and conditions of your coverage.

Please refer to this document for detailed information regarding the duration of the warranty, what is covered, and the process for making a claim. We recommend retaining your proof of purchase along with the warranty document for convenient reference. For any warranty-related inquiries, please contact your authorized BAT dealer or reach out to us directly using the contact information provided in this manual."

Disclaimer

Information contained in this manual is subject to change without prior notice and does not represent a commitment on the part of the vendor. We shall not be liable for any loss or damages whatsoever arising from the use of information or any error contained in this manual.

It is recommended that all services and repairs on this product be carried out by us or its authorized dealer.

This product must only be used for the purpose it was intended by the manufacturer and in conjunction with this operating manual.

We cannot accept any liability whatsoever for any loss or damages caused by "service, maintenance or repair by unauthorized personnel" or by use other than that intended by the manufacturer.

Contact Us

info@bataudio.com
www.bataudio.com
United Kingdom

 **BAT.**
BRITISH ACOUSTIC TECHNOLOGY