

# BLOQ 5

Data Sheet

# BLOQ 5

## Ultimate All-Weather Sound

The **BLOQ** series is a compact all-weather speaker engineered for commercial applications. Built to deliver stunning sound quality in harsh environments, it meets the IEC529 IP55 standard with a robust ABS cabinet and flexible installation options powered by 70-100V or low-impedance.

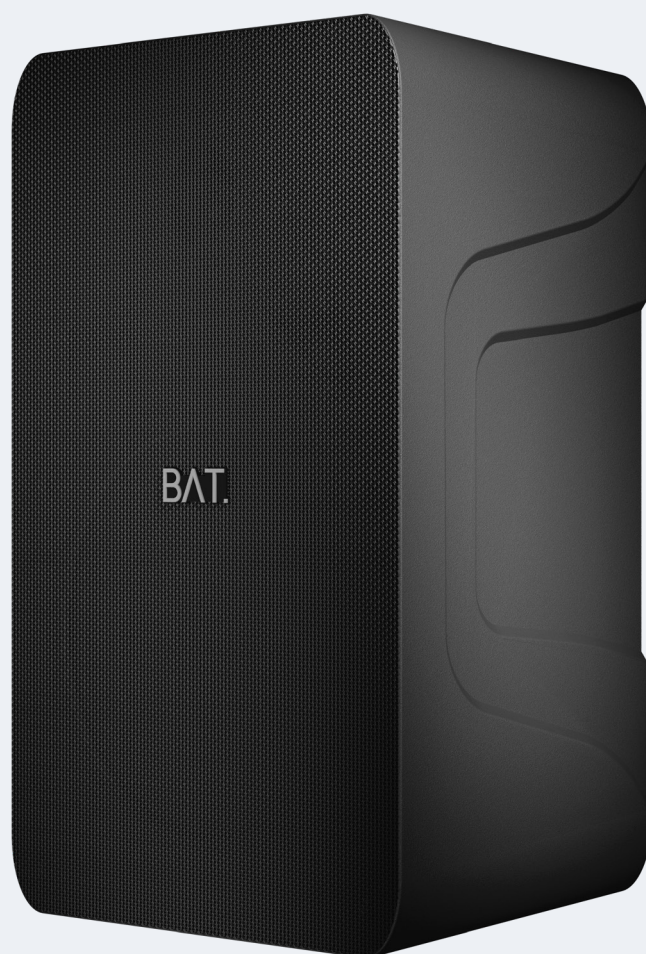

## Big Sound, Built to Weather It All

The **BLOQ** series delivers uncompromised performance as compact all-weather speakers engineered for both indoor and outdoor environments. Built to meet the IEC529 IP55 standard, they offer robust dustproof and waterproof protection while delivering stunning sound quality with clear treble and powerful bass.

## Engineered for Clarity, Built for Every Space

This thoughtfully designed lineup guarantees reliable, high-fidelity audio performance in dynamic public spaces, meeting rooms, and other challenging installations.

# Technical Specifications

Unit	BLOQ 5
Power Tapping:	3.75W-7.5W-15W-30W
Rated Power:	30W
Line Input:	70-100V/8Ω
Sensitivity:	89dB
Max Sensitivity:	107dB
Frequency Response:	80~20KHz
Dimension (DxWxH):	145x175x255mm
Material:	ABS
Weight:	2.72kg
Speaker Unit:	5" Woofer + 1" Tweeter
Colour:	White/Black
IP Rating:	IP55

## Dimensions

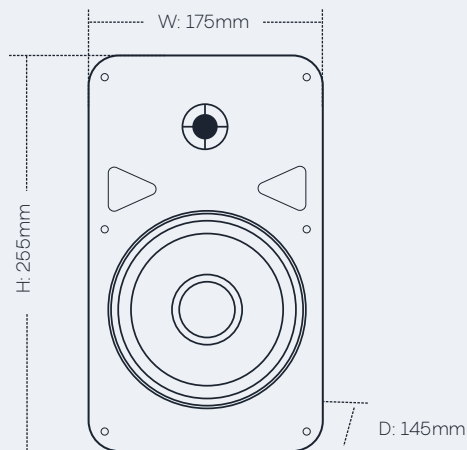

# Technical Data

## Surface-Mount Loudspeaker

### Frequency Response

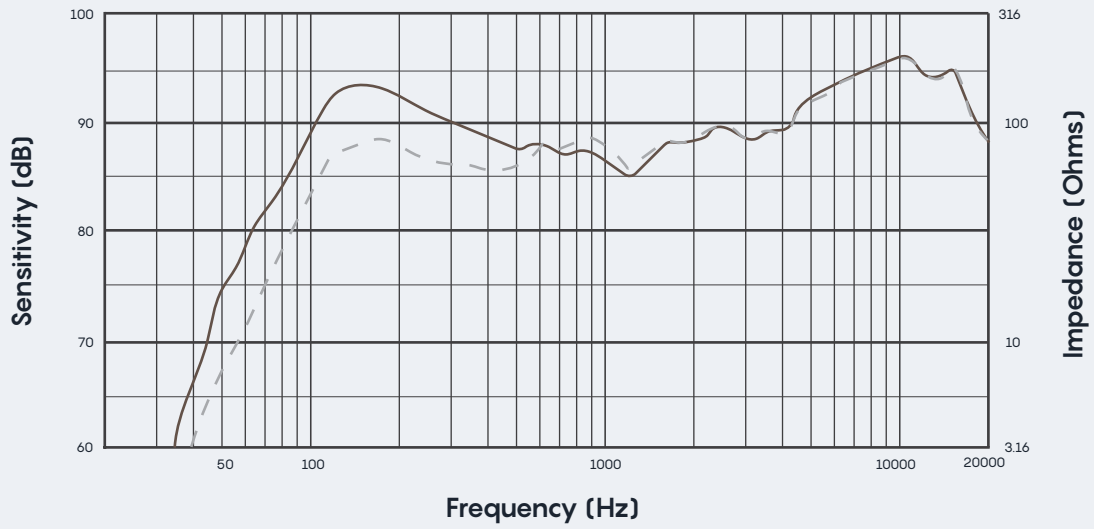

### Impedance

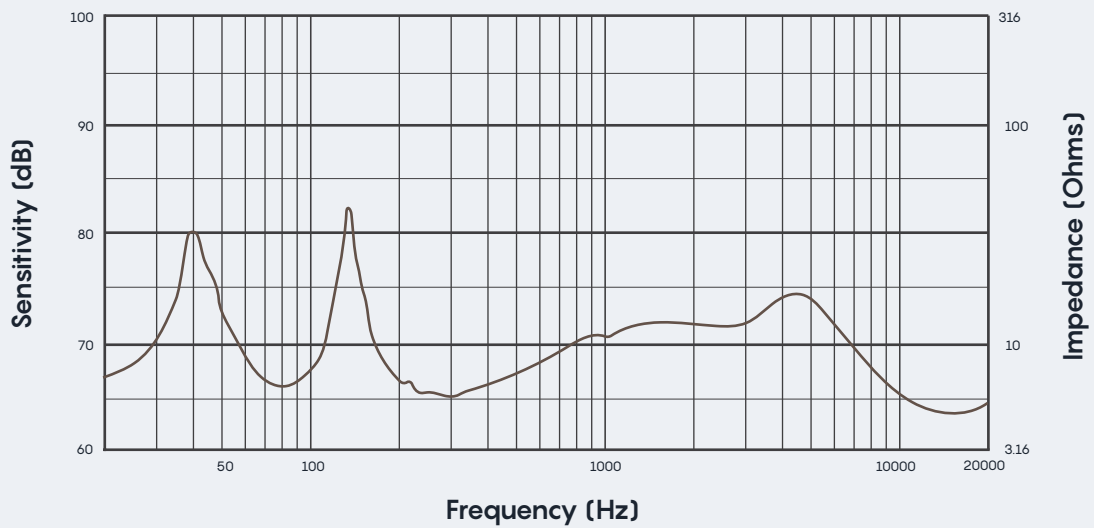

# Contact Us

---

[info@bataudio.com](mailto:info@bataudio.com)  
[www.bataudio.com](http://www.bataudio.com)  
United Kingdom

 **BAT.**  
BRITISH ACOUSTIC TECHNOLOGY