

EVOQ 8T

Data Sheet

EVOQ 8T

All-Weather Sound Mastery

The EVOQ series are compact waterproof fashion speakers built with an international advanced mold and a thickened high-strength ABS cabinet for durability. Designed with a clever mounting bracket and IP55-rated for dust and water resistance.



Versatile Sound, Built to Last

100V constant voltage versions, this speaker is built with a robust ABS enclosure and aluminum mesh, available in optional black and white finishes.

Rugged. Reliable. Ready for Any Weather!

The all-weather speaker is engineered for a wide range of applications, delivering stunning and extraordinary sound quality while meeting the IEC529 IP55 standard for dust and water resistance. Designed specifically for the professional audio and commercial audio markets.

Technical Specifications

Unit	EVOQ 8T
Rated Power:	120W@100V
Max Power:	180W@100V
Sensitivity (1W / 1m):	95dB SPL (125 Hz-12.5 kHz @3/1 Octave Frequency Band) 96dB SPL (250 Hz-4 kHz)
Max Sensitivity:	118dB SPL@110V
Frequency Response (-10dB):	70Hz~20kHz
Diffusion Angle (4kHz / 1kHz):	115° Cone (+46°/-46°, 500Hz to 6kHz)
Power Selection Method:	Phoenix Terminal Interface
Material:	Enclosure: ABS; Mesh Cover: Metal
Colour:	White/Black
Operating Conditions:	-30°C~60°C; <95% Humidity
IP Rating:	IEC529 IP55
Speaker Unit:	8" Woofer + 1.25" Tweeter
Dimension (DxWxH):	257x230x470mm
Net Weight:	8.5kg
Installation:	Hidden Mounting Bracket
Gross Weight:	19kg, 2 pcs

Dimensions

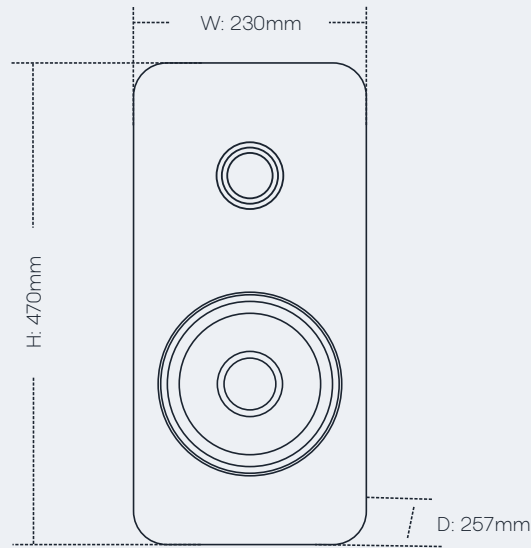

Technical Data

Surface-Mount Loudspeaker

SPL vs Frequency Response

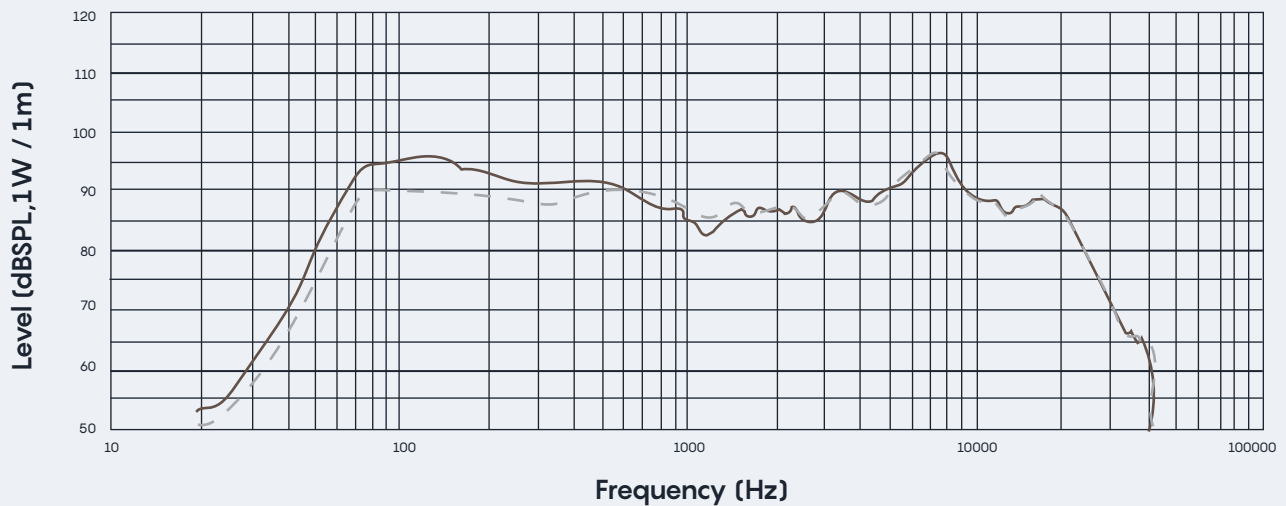

Contact Us

info@bataudio.com
www.bataudio.com
United Kingdom

 **BAT.**
BRITISH ACOUSTIC TECHNOLOGY