RIPL 6II

Data Sheet

RIPL 6 II

Dynamic Sound, Durable Design

The RIPL series is compact, waterproof fashion speaker featuring a robust, thickened ABS enclosure and a cleverly designed mounting bracket that ensures versatile installation. With an IP55 dustproof and waterproof rating, these speakers excel in all-weather conditions, making them perfect for outdoor applications such as cultural tourism projects, commercial pedestrian and bar streets, villas, swimming pools, golf courses, and sports fields, as well as indoor venues like conference rooms and banquet halls



Smart Inputs, Superior Output

These speakers come with a matching transformer offering multi-tap selections for 70-100V or low-impedance, making them ideal for professional audio and public address systems.

Easy Mounting, Flexible Direction

The speakers also feature a user-friendly U-shaped mounting bracket for quick, flexible installation and adjustable sound directivity, ensuring stunning sound quality wherever they are used.

Technical Specifications

Unit	RIPL 6II
Rated Power:	60W@100V, 90W@8Ω
Max Power:	90W@100V, 180W@8Ω
Impedance:	83Ω, 167Ω, 333Ω, 667Ω, 1.33kΩ
Power Tapping:	100V: 60W, 30W, 15W, 7.5W; 70V: 60W, 30W, 15W, 7.5W, 3.75W
Sensitivity (1W/1m):	92dB (±3dB)
Max Sensitivity:	110dB@100/70V, 112dB@8Ω
Frequency Response:	80Hz~16kHz (-10dB)
Power Selection Method:	Rotary Selector Switch
Material:	Enclosure: ABS, Mesh Cover & Bracket: Aluminum
Colour:	Black/White
Operating Conditions:	-30°C~60°C; <95% Humidity
IP Rating:	IEC529 IP55
Speaker Unit:	6.5" Woofer + 1" Tweeter
Dimension (DxWxH):	201x295x320mm
Net Weight:	3.8kg

Technical Specifications

Unit	RIPL 6II
Installation:	Adjustable Angle U-shaped Mounting Bracket, Can be Installed Horizontally or Vertically
Gross Weight:	9.6kg, 2pcs
Inner Packing Dimensions:	295(W)x398(H)x265(D)
Packing Dimensions:	0.069CBM, 52x42x31.5cm, 2pcs

Dimensions

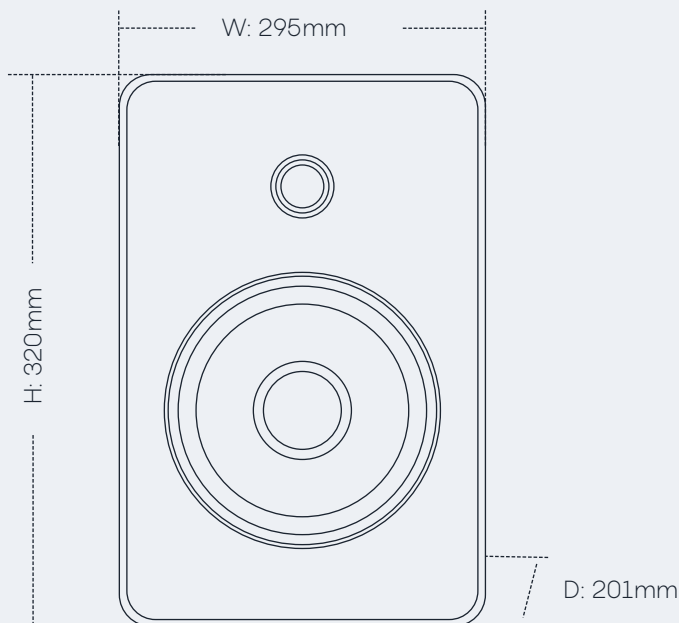

Technical Data

Surface-Mount Loudspeaker

Frequency Response

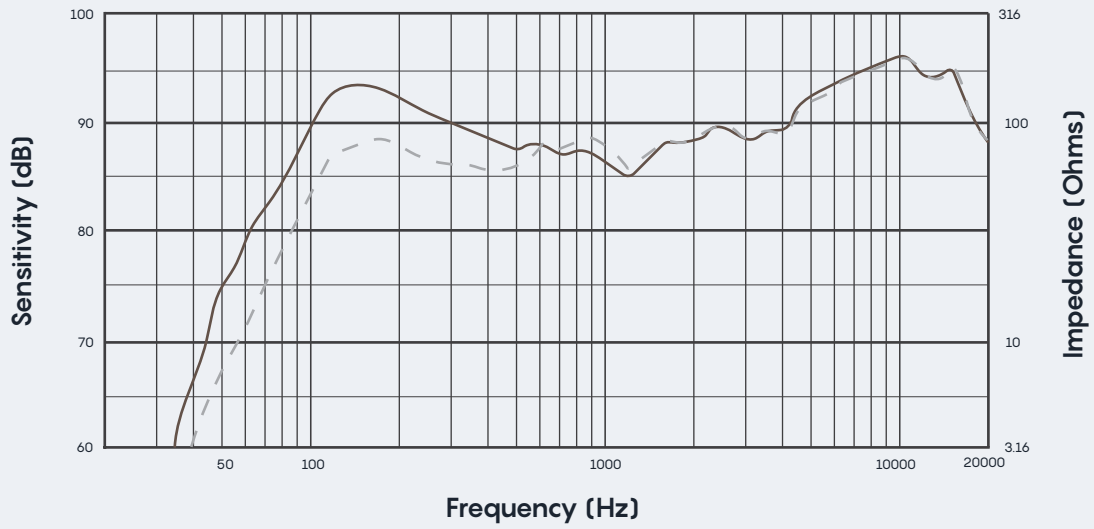

Impedance

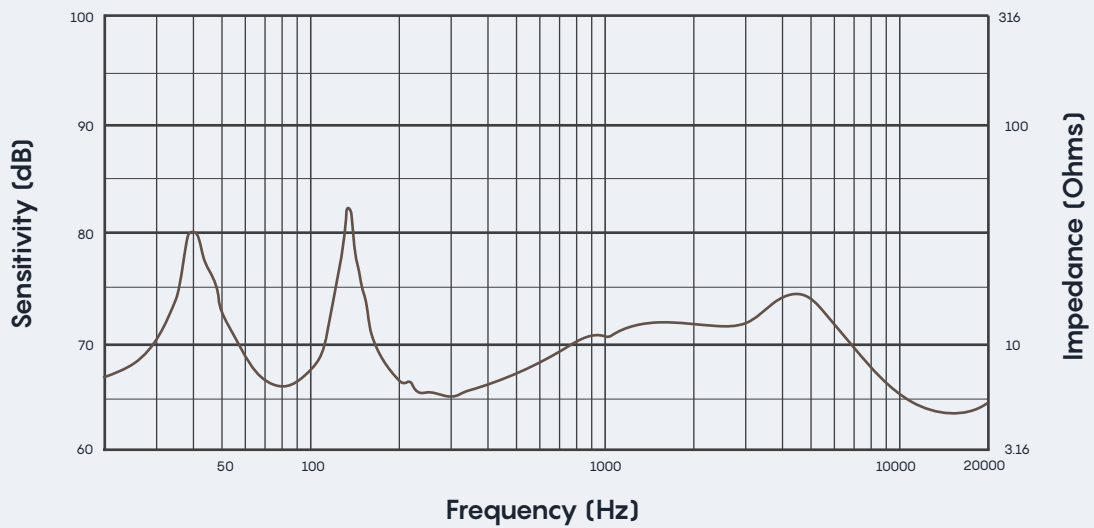

Contact Us

info@bataudio.com
www.bataudio.com
United Kingdom

 **BAT.**
BRITISH ACOUSTIC TECHNOLOGY