

MHW 6836 BASIS PLUS

Laboratory- and test lead trolley

- base frame- / base trolley composed of frame profiles, base plate (max. load capacity: 30 kg), antistatic tires (2 lockable) and:
- 1 shelf, 520 x 165 mm, with cable slots, on intermediate supports, for the storage of up to 120 measuring leads. Max. load capacity: 10 kg
- 1 shelf, 520 x 169 mm, on intermediate supports, for the storage and plug-in of test probes and other test accessoires on Ø 4 mm lamella-basket plugs. Max. load capacity: 10 kg
- 1 shelf, 520 x 300 mm, on intermediate supports, or the storage of measurement instruments and -equipment. Max. load capacity: 20 kg

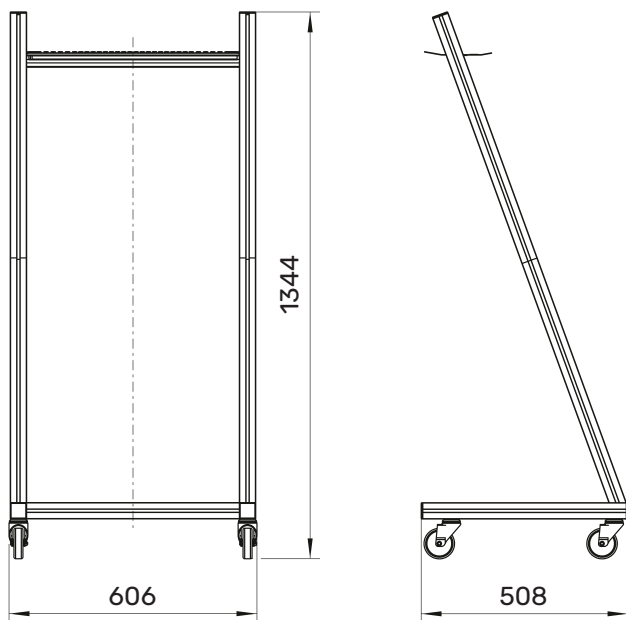

MA 009



General information

Order No.¹⁾ **MHW 6836 / BASIS PLUS**

colours white aluminium

Technical data

sizes, W x H x D 606 mm x 1344 mm x 508 mm

profile material aluminium, anodised

shelf material steel, powder-coated

¹⁾ other designs on request

MHW 6836 BASIS PLUS



99014643