



INFORMATION FOR FIRST AND SECOND RESPONDERS  
EMERGENCY RESPONSE GUIDE FOR VEHICLE



Leapmotor C10

Electric vehicle



## Catalogue

<b>0. Rescue sheet</b>	<b>Page 1</b>
<b>1. Identification / recognition</b>	<b>Page 2</b>
<b>2. Immobilisation / stabilisation / lifting</b>	<b>Page 4</b>
<b>3. Disable direct hazards / safety regulations</b>	<b>Page 6</b>
<b>4. Access to the occupants</b>	<b>Page 11</b>
<b>5. Stored energy / liquids / gases / solids</b>	<b>Page 16</b>
<b>6. In case of fire</b>	<b>Page 20</b>
<b>7. In case of submersion</b>	<b>Page 22</b>
<b>8. Towing / transportation / storage</b>	<b>Page 23</b>
<b>9. Important additional information</b>	<b>Page 25</b>
<b>10. Explanation of pictograms used</b>	<b>Page 26</b>



# Leapmotor C10

5 doors, 5 seats, SUV  
2026-

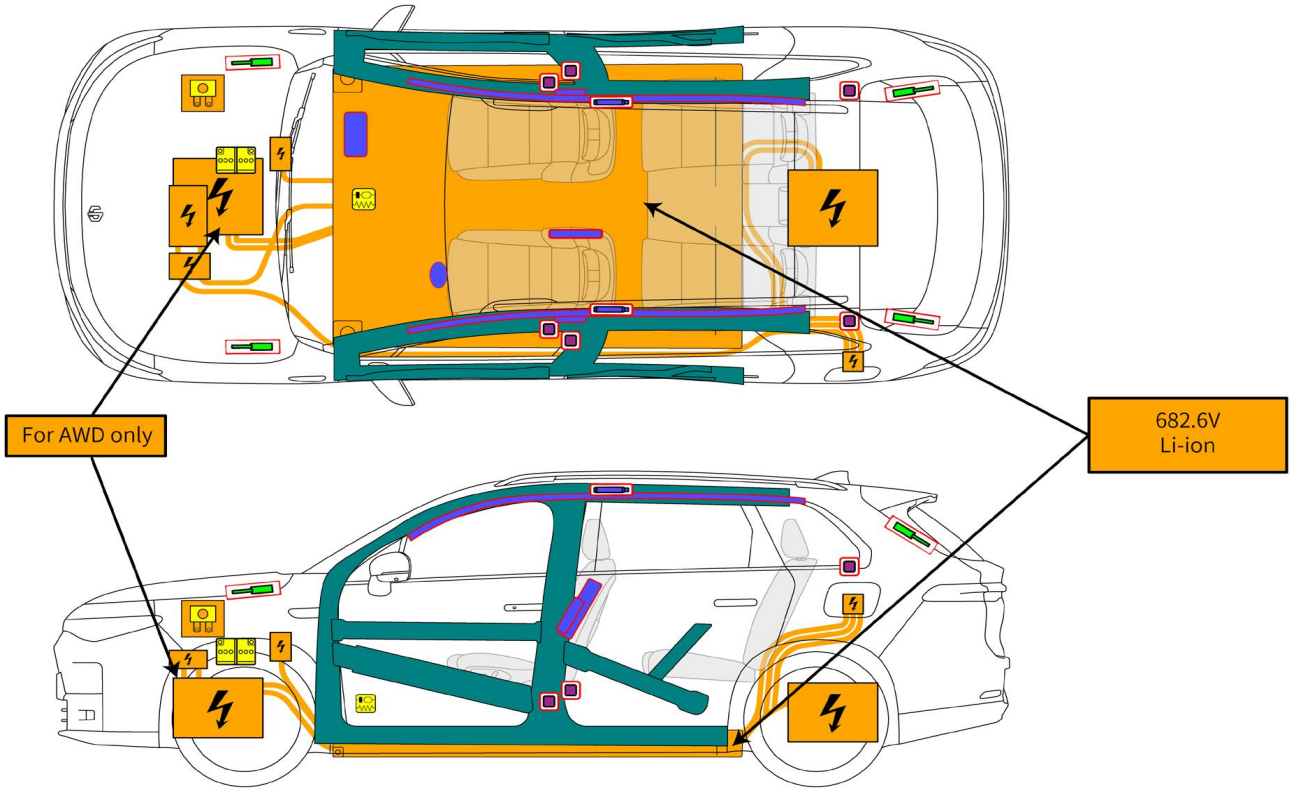

	Airbag		Stored gas inflator		Seat belt pretensioner		SRS control unit
	Battery low voltage		Gas strut / Preload-ed spring		High strength zone		Battery pack, high-voltage
	High voltage power cable		Fuse box disabling high voltage		Battery bank high voltage		

	Leapmotor C10	Document number	Version No.
	2026-	Leapmotor-2026-001	01

## 1. Identification / recognition



LACK OF ENGINE NOISE DOES NOT MEAN VEHICLE IS OFF: SILENT MOVEMENT OR INSTANT RESTART CAPABILITY EXISTS UNTIL VEHICLE IS FULLY SHUT DOWN. WEAR APPROPRIATE PPE.

### Appearance identification

Leapmotor C10 can be identified through the vehicle logo and the vehicle identification on the tailgate.

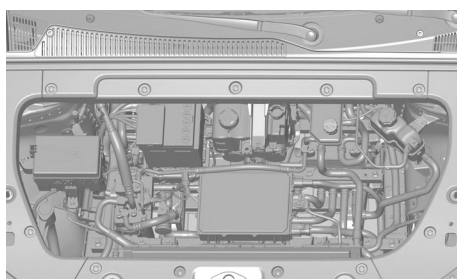
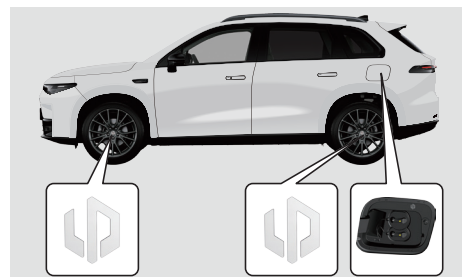
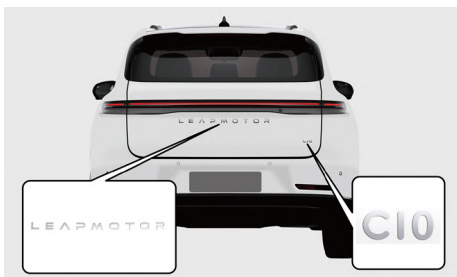

### Vehicle identification number (VIN)

Leapmotor C10 can be identified through the vehicle identification number (VIN). The VIN is located on the sheet metal cross beam at the left lower side of the front windshield (pasted).

The VIN is the vehicle's identity code, which is unique, consisting of 17 characters, including information such as manufacturing country, manufacturer, year, vehicle feature code, etc. The VIN can also be found in various locations such as the left shock tower (pasted), front part of the bonnet inner panel (pasted), left front door sheet metal (pasted), sheet metal of the inner panel at the left side of tailgate (pasted), right rear wheel housing (pasted), right front door sheet metal (pasted), and floor cross member under the passenger seat (engraved).



## Vehicle key

Leapmotor C10 has three types of keys:

- **NFC Card Key** - By tapping the NFC recognition area on the driver side exterior rearview mirror with a valid NFC card key for at least 1s, the vehicle can be unlocked or locked when the NFC key is detected.



- **Cell Phone Bluetooth Key** - Leapmotor C10 can use a Bluetooth key connected to the vehicle instead of traditional vehicle keys for vehicle control. To be recognized as a valid key, the cell phone must establish a Bluetooth connection with the vehicle and complete authentication. Please refer to the *User Manual* for information on connecting the cell phone to the vehicle as a Bluetooth key.



- **Mechanical Key** - If the NFC card key and cell phone Bluetooth key of Leapmotor C10 cannot unlock/lock the door, use the mechanical key to unlock/lock the driver side door.

1. Manually press the front end of the driver side door handle to expose the mechanical lock cylinder.
2. Insert the mechanical key into the lock cylinder. Turn the key clockwise to unlock the driver side door; turn the key counterclockwise to lock the driver side door.

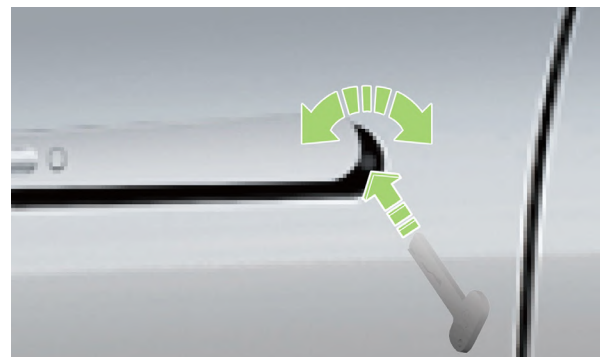

• The mechanical key is provided separately with the vehicle and is not integrated with the NFC card key. Please avoid losing the mechanical key.

## 2. Immobilisation / stabilisation / lifting

### Fixing



#### 1. Vehicle parking

Depress the brake pedal to bring the vehicle to a smooth stop, then press the button at the top of the gear shift lever to switch to the P gear to engage the parking brake.

When Leapmotor C10 is in the P gear, the parking brake will automatically engage, the P gear indicator on the instrument cluster will light up. Release the brake pedal, and the vehicle parking is completed.



#### 2. Fixing the wheels

To prevent the danger caused by failure to fix wheels, place wedges in front and behind all four wheels to effectively prevent the vehicle from moving accidentally.

#### 3. Confirm vehicle ON/OFF

Use a legal NFC key to touch the card swiping area (driver's exterior rearview mirror) for 1s. After the vehicle detects the NFC key, the ON/OFF function can be realized.

①: Exterior rearview mirrors unfolded. Meanwhile, the direction indicator lamp flashes twice and the vehicle switches from OFF to ON.

②: Exterior rearview mirror folded. Meanwhile, the direction indicator lamp flashes once, the horn sounds, and the vehicle switches from ON to OFF.



Be careful not to damage the battery pack when stabilizing the vehicle!

The automatic folding/unfolding of the rearview mirror and the door lock chimes can be set on/off on the Infotainment Screen.

## Stabilizing / lifting points

The traction battery of Leapmotor C10 is located under the vehicle base plate. The traction battery occupies most of the space under the vehicle. When lifting the Leapmotor C10, only the designated lifting areas (green areas) can be used.



Be careful not to damage the traction battery when stabilizing/lifting the vehicle!





Only professional staff wearing professional equipment and familiar with the lifting points of the vehicle can lift the vehicle. Handle with care during use to ensure that there is no contact with the traction battery or other high-voltage components when lifting/lowering the vehicle!

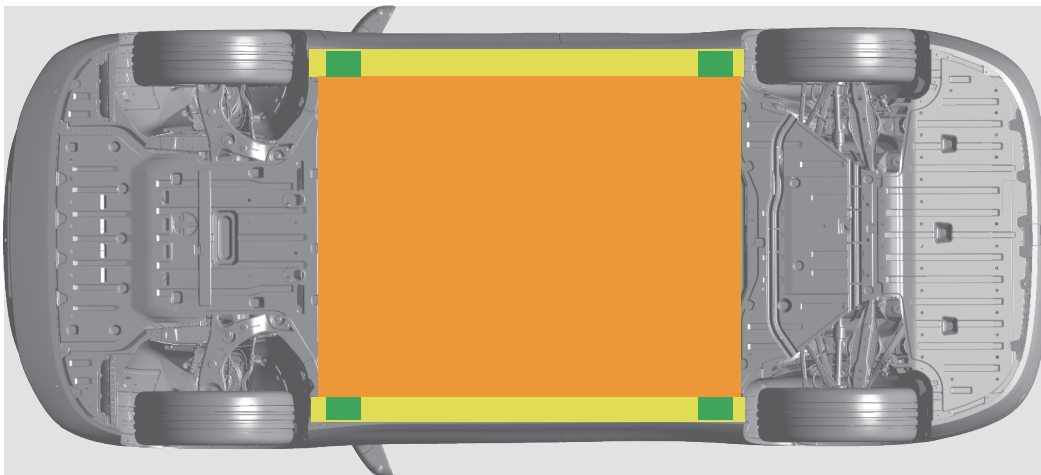

Do not use the area where the traction battery of Leapmotor C10 is installed for lifting operations!



	Safe lifting point
	Side safe stabilizing point
	Traction battery

### 3. Disable direct hazards / safety regulations

#### Cut off emergency response circuit

The front engine compartment hood release handle is located on the lower left side of the instrument panel. Pull the hood release handle twice and lift the front engine compartment hood to open it.



#### Main disabling method

After opening the bonnet, locate and open the front engine compartment fuse box cover, High voltage fuses FF14 and FF20 must be removed both.

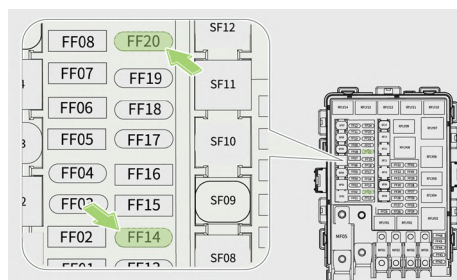
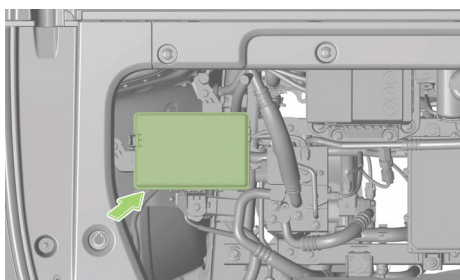

Wear appropriate PPE (rubber insulating gloves/insulated rubber shoes/tools with insulating protective sleeve/goggles). Do not attempt to open the traction battery!



#### Emergency unlocking of AC slow charger

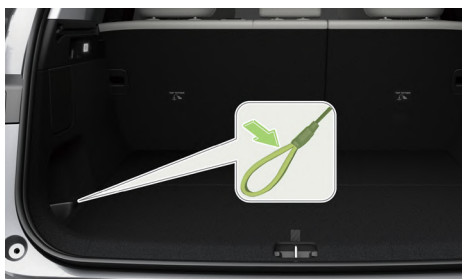

1. When the vehicle is being charged by AC slow charger, if the charger cannot be unplugged after multiple unlockings, you can open the liftgate and remove the storage box on the left side of the trunk.
2. Find the emergency unlocking mechanical cable of the AC slow charger, pull the unlocking cable, and then pull out the charger.



## Fuse box disabling high voltage

When unplugging the high-voltage fuse, if the emergency response circuit is cut off, the low voltage battery of the traction battery will be disconnected, and the high-voltage contactor inside the traction battery will be disconnected to cut off the high-voltage output of the vehicle high voltage components.

The cut off emergency response circuit is located inside the fuse box on the right side of the front compartment of the vehicle.

The high-voltage contactor acts like a light switch. When it is "ON" or in the "OFF" position, the lights in the room will turn off, isolating the high voltage to the battery pack. When it is "OFF" or in the "ON" position, the lights in the room will turn on, connecting the high voltage in the battery pack to the high voltage components. On Leapmotor C10, high-pressure components include the drive system, compressor, water heater, charging system, etc.

When the vehicle is involved in an accident and the emergency response circuit is cut off, the battery pack and the high voltage components must always be considered live because the battery pack will still store energy in the battery and it is not known if other high voltage components are damaged. Consider each orange cable and battery pack as a high voltage. Do not disconnect the orange high voltage power cable or damage the battery pack.

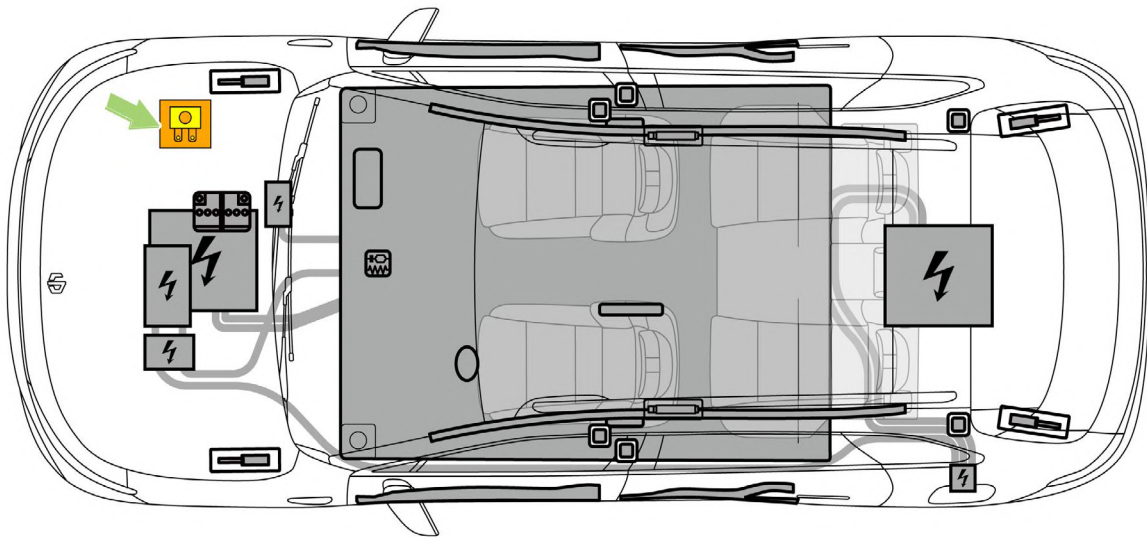

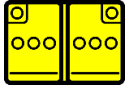

## Battery low voltage

The low-voltage 12V battery is located in the engine compartment, and the battery should be installed correctly and securely fixed with a battery pressing plate.

The fixing clamps for the poles of the low-voltage battery should be installed securely and in good contact to prevent sparks and fires.

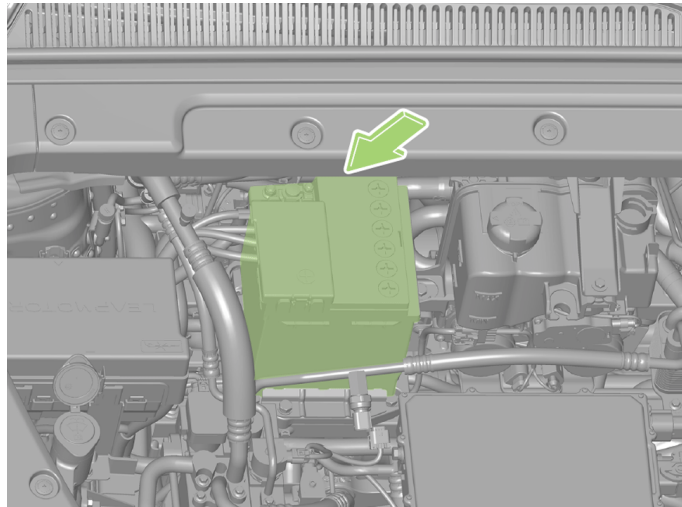

Vehicle power-off: Open the front engine compartment hood, use tools to loosen the nut fixing the negative pole of the battery, unplug the low-voltage battery negative cable, and disconnect the low-voltage battery power.

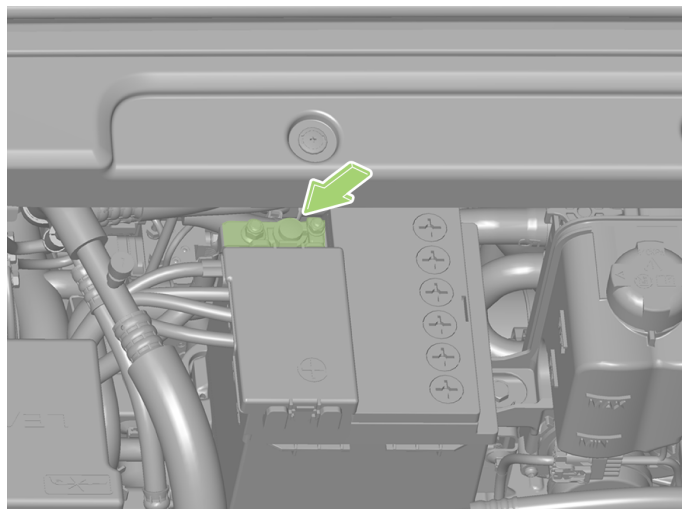

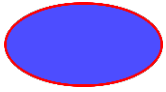

## Airbag

The airbag is located in the approximate area shown in the diagram below. The airbag warning information is printed on the sun visor.

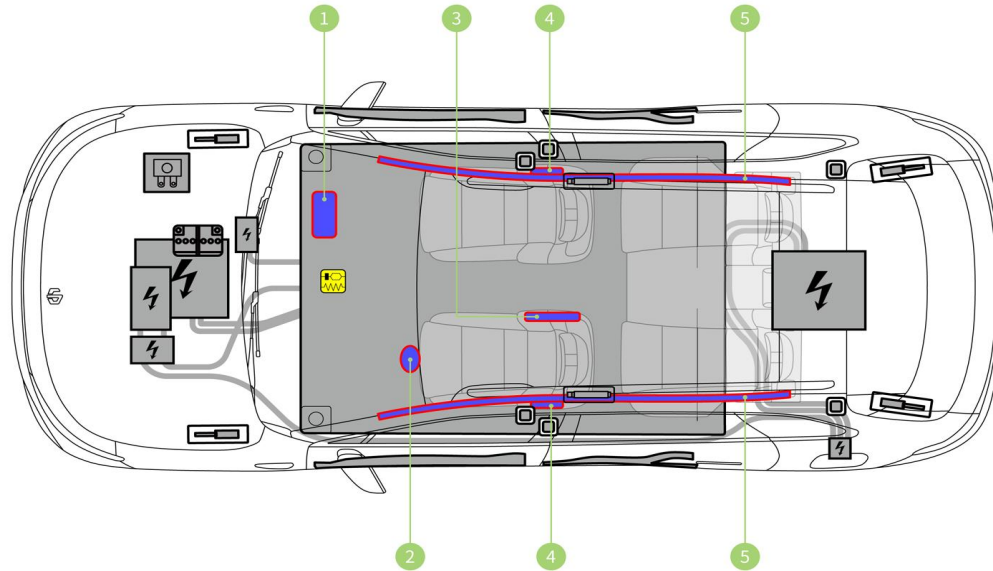

- 1 Front passenger seat airbag
- 2 Driver airbag
- 3 Front-row side airbag
- 4 Far-side airbag
- 5 Side curtain airbag

When the airbag are deployed by the SRS control unit, a fuse that disables the vehicle's high-voltage system will also be triggered.

When the airbag deploys, all high voltage components and cables of Leapmotor C10 outside of the traction battery will lose high voltage. Caution! Do not cut off any orange high voltage power cables or attempt to restart the battery pack. Even if the high-voltage system is shut down due to the deployment of the airbag, it must be assumed that there may still be high-voltage power in all high voltage components and power cables. The traction battery units inside the battery pack are used to store energy and must not be damaged by rescue tools.



### Stored gas inflator

The stored gas inflator, marked in red, is located near the roof at both ends of the B-pillars.

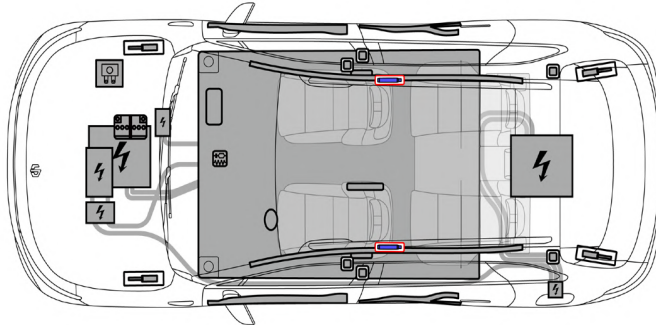

Rescue personnel must not cut off or damage the stored gas inflator. Cutting or compressing the stored gas inflator can result in catastrophic failure, leading to injury or death.



The SRS control unit has a backup power supply that discharges in approximately 10s. Do not touch the SRS control unit within 10s after the airbag or pretensioner deploys.



### Seat belt pretensioner

The seat belt pretensioner is located at the bottom of the B-pillars and on the outer side of the second-row seats.

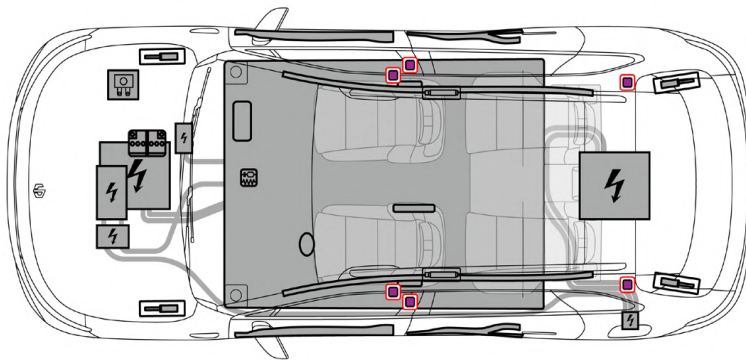

The SRS control unit has a backup power supply that discharges in approximately 10s. Do not touch the SRS control unit within 10s after the airbag or pretensioner deploys.



## 4. Access to the occupants

The front seats are electrically adjusted and may not work after a collision.

After a collision, the tailgate may not be opened from the outside. Emergency opening from the inside is required.

### Open doors from the outside

When the vehicle is unlocked, press the door handle to raise the rear end of the handle, then pull it to open the door. After release, the door handle will automatically retract.

If the vehicle is not powered on and the NFC key card cannot be used to unlock, use the mechanical key to open the driver side door. Refer to vehicle key - mechanical key.



### Open doors from the inside

When the doors are unlocked, locate the interior door handle. Pull up the interior door handle towards the inside to open the corresponding side door.





## Boot

Use the following methods to open the tailgate:

1. On the centre console display screen, open "Settings-Doors and Windows" interface, touch the tailgate button on the "Doors and Windows" interface to unlock/open the tailgate (the power tailgate can open automatically, while the manual tailgate needs to be lifted manually).
2. Press the button located on the liftgate to unlock/open the liftgate (the power liftgate can open automatically, while the manual liftgate needs to be lifted manually).

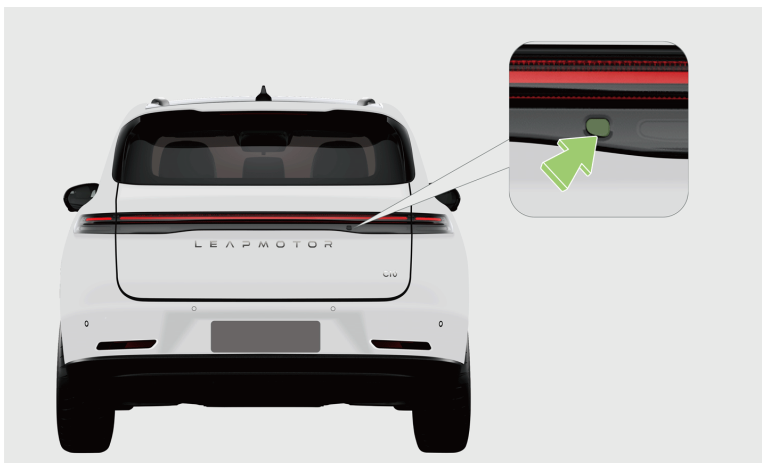

## Steering wheel, tilt control

The steering wheel adjustment handle is located under the steering column shield. Adjustment method:

1. Release the steering wheel adjustment handle outward.
2. Hold the steering wheel tightly with both hands and adjust the steering wheel forward, backward, up and down to the appropriate position.
3. After proper adjustment, push back the steering wheel adjustment handle and lock the steering wheel.
4. Shake the steering wheel up and down to confirm that the steering wheel is securely locked in the front and back, up and down positions.





## Seat adjustment, longitudinal / Seat height adjustment

Leapmotor C10 is equipped with power seats that can be adjusted in 6 directions.



Push the seat position adjustment switch forward or backward in the direction indicated by arrow ①, the seat will slide forward or backward. Release the adjustment switch and the seat stops.

Push or press on the seat position adjustment switch in the direction indicated by arrow ②, the seat will raise or lower. Release the adjustment switch and the seat stops.

Push the seat position adjustment switch forward or backward in the direction indicated by arrow ③, the backrest will lean forward or backward. Release the adjustment switch and the backrest stops.

The power seats will not be adjustable when the vehicle is not powered on.

When performing passenger rescue, always check the rear seat area for passengers to avoid missing anyone.



## Bonnet

The front engine compartment hood release handle is located on the lower left side of the instrument panel. Pull the hood release handle twice and lift the front bonnet to open it.





## High strength zone

Leapmotor C10 has been reinforced to protect occupants in collisions. Use appropriate tools to cut or crush these areas.

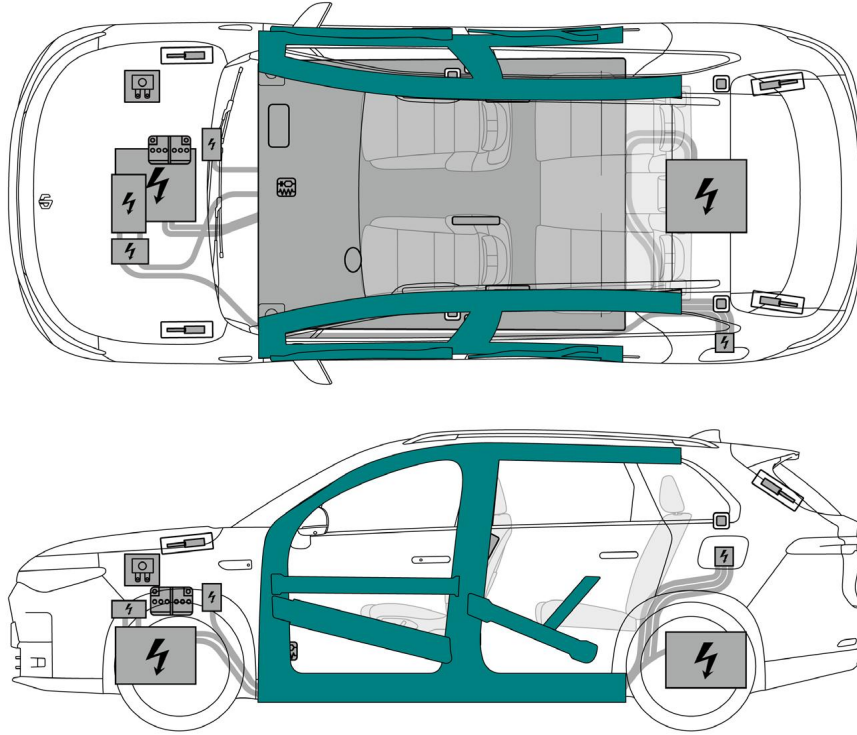



When cutting Leapmotor C10, be sure to use the appropriate tools, such as a hydraulic cutting machine, and wear proper personal protective equipment. Failure to follow these instructions may result in serious injury or death.



Regardless of the tool used, always assume all high voltage components are live! Cutting, crushing, or contacting with high voltage components can result in serious injury or death.

## Vehicle cutting area

Due to the presence of high voltage, stored gas inflators, gas springs, and other hazardous units, some areas are defined as "Prohibited cutting area".

Cutting or crushing in these areas is prohibited. As this may result in serious injury or death. The "Prohibited cutting area" is indicated in pink.

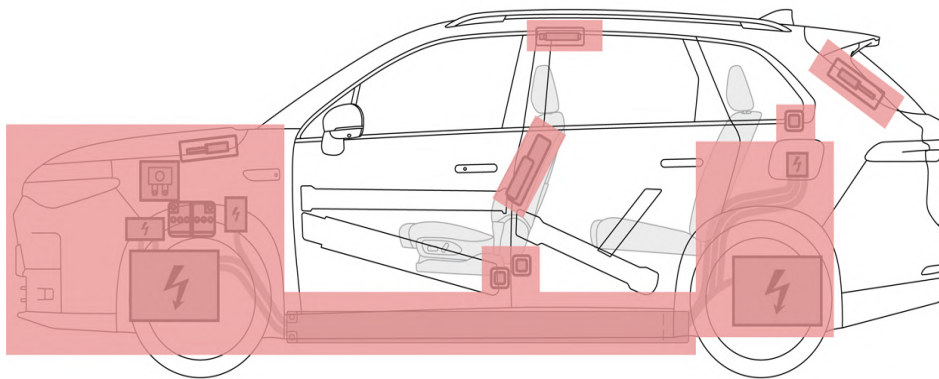

: Prohibited cutting area.





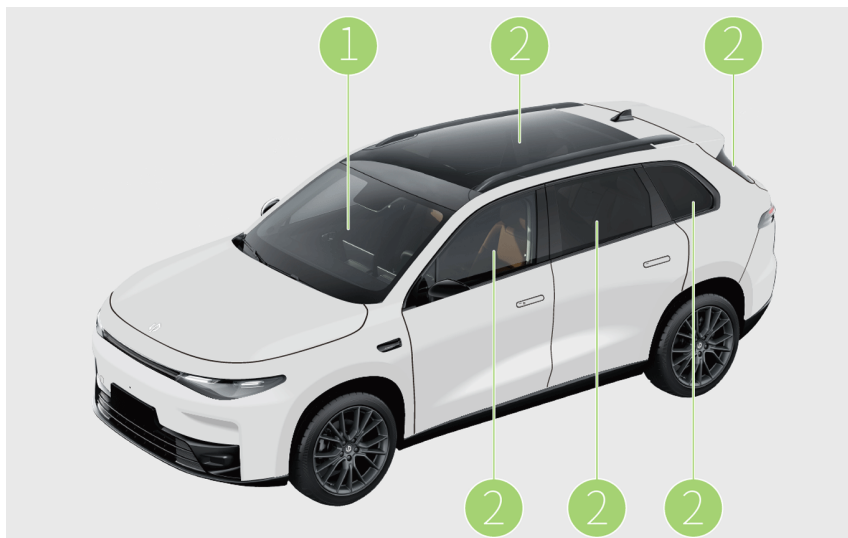





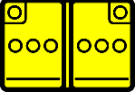



## Glass type

The front windshield is laminated glass, while the rest are tempered glass.



- ① Laminated glass
- ② Tempered glass

## 5. Stored energy / liquids / gases / solids

	  	12V
	     	682.6V
	 	1100±20g



When the coolant leaks from a battery pack, it can become unstable, posing a risk of thermal runaway. Check the battery pack temperature with a thermal infrared camera.



If the vehicle is involved in a crash that results in the leakage of traction battery liquid, it should be handled by a professional rescuer, who must wear the correct personal protective equipment and never touch the liquid directly.



### Battery pack, high-voltage

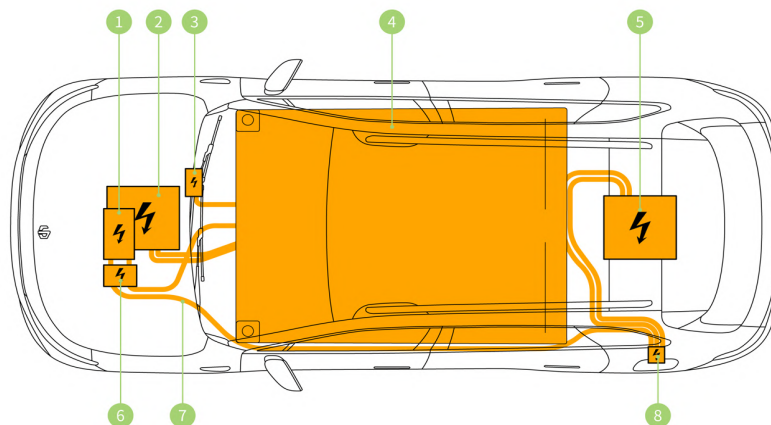

- 1 Two-in-one power supply assembly
- 2 Front drive motor ( For AWD only )
- 3 Electric compressor
- 4 Traction battery
- 5 Rear drive motor
- 6 Charging port
- 7 High voltage power cable (front engine compartment)
- 8 Charging port



## Battery pack, high-voltage

Leapmotor C10 is equipped with a 682.6V Li-ion battery. Do not touch the liquid leaking from the traction battery (if any).

Do not damage the traction battery when lifting the vehicle from the underside. Be especially careful not to damage the chassis when using rescue tools.

Please refer to Chapter 2: Lifting for instructions on how to properly lift the vehicle.

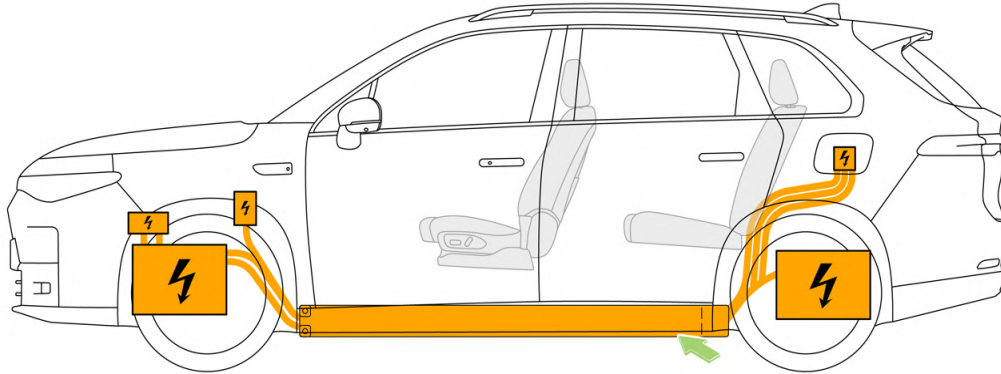

## Vehicle chassis

The traction battery is located under the base plate. Do not squeeze the chassis inside the Leapmotor C10, as this may damage the traction battery or high-voltage cables,

leading to serious injury or death. Rescue tools should never be used on the traction battery.

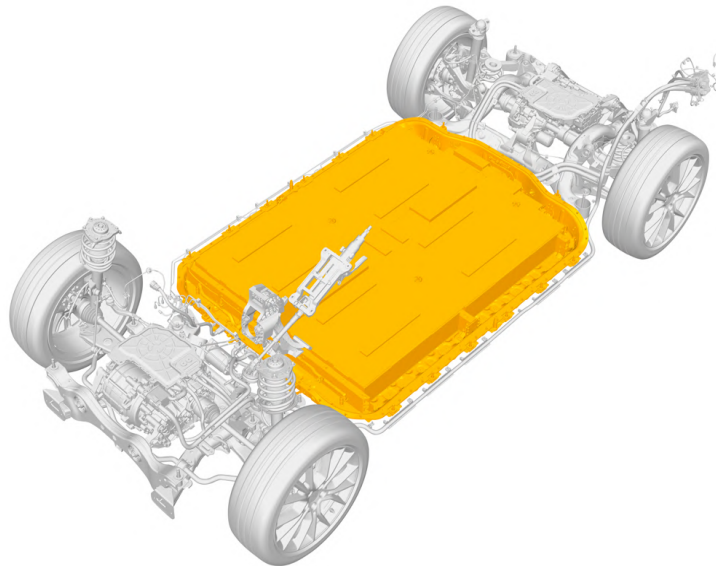



## High voltage power cable

High voltage power cables are indicated in orange-yellow. Rescue tools must not damage these high voltage power cables. At no time should any high voltage power cable be damaged by rescue tools. It should be assumed that high voltage is present in orange-yellow high voltage power cables at all times.

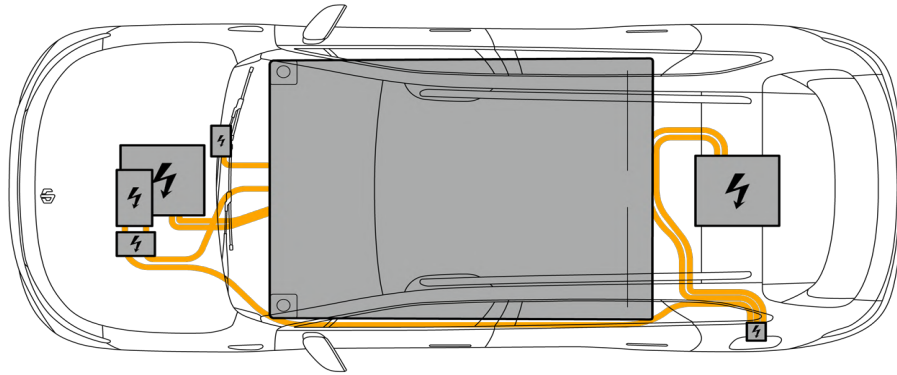

## Drive motor

Rear drive motor is located between the rear wheels, Front drive motor ( For AWD only ) is located between the front wheels. The drive inverter is located inside the drive motor. The drive motor converts the DC from the traction battery into AC for driving the wheels.

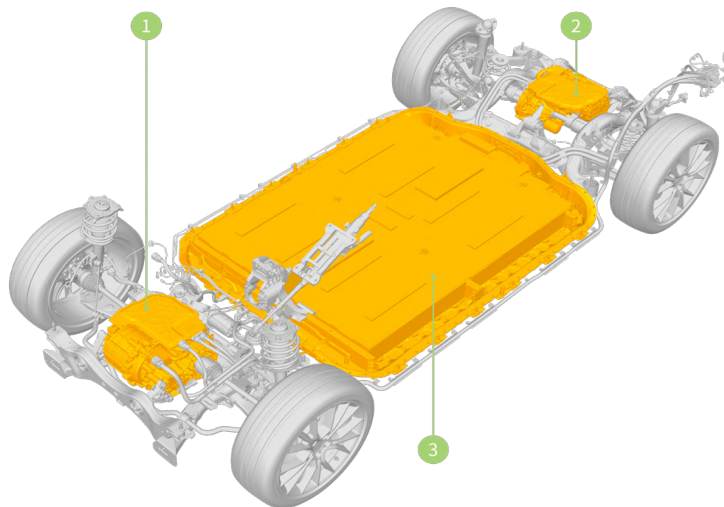

- ① Front drive motor ( For AWD only )
- ② Rear drive motor
- ③ Traction battery

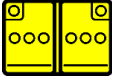

## Battery low voltage

In addition to the high-voltage system, Leapmotor C10 also has a low-voltage electrical system. Its low-voltage battery powers the supplemental restraint system, SRS, windows, door locks, centre console display screen, and lights. The high-voltage system charges the low-voltage battery, which powers the high-voltage contactor to allow high-voltage current to flow in or out of the traction battery.

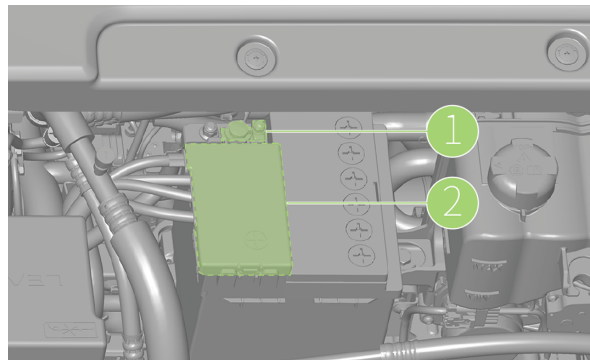
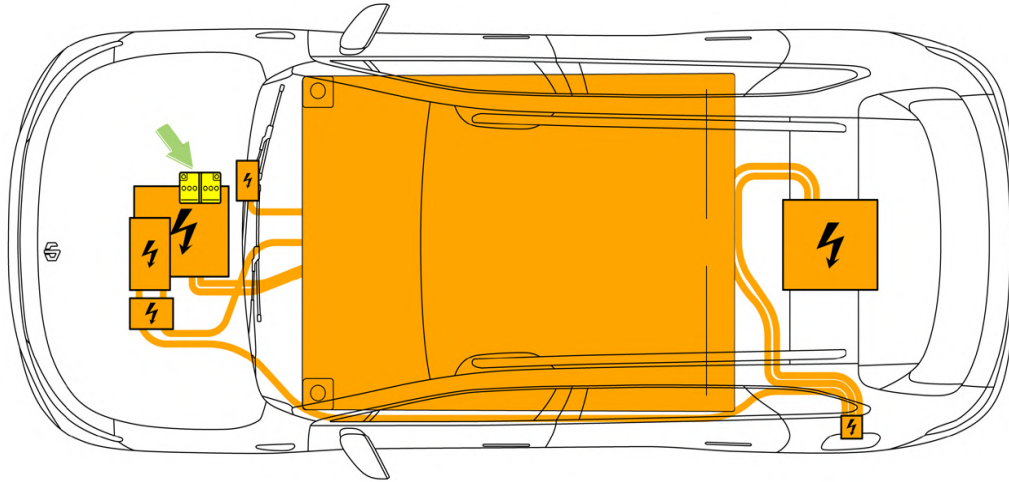

- ① Low-voltage battery negative
- ② Low-voltage battery positive

## 6. In case of fire

### Fire extinguishing



Do not submerge the vehicle in water to extinguish the burning battery.



Use water to extinguish the fire.



**BATTERY RE-IGNITION!**

Monitor the temperature of the traction battery for at least 24 hours.



Use water to extinguish traction battery fires. If the battery is on fire, overheating, or generating heat or gas, use a large amount of water to cool the battery. If water is not available, use other typical fire extinguishing agents such as carbon dioxide, foam, etc. (do not use dry powder fire extinguishers).

Explosive risk for gas strut / Preloaded spring of bonnet and liftgate!

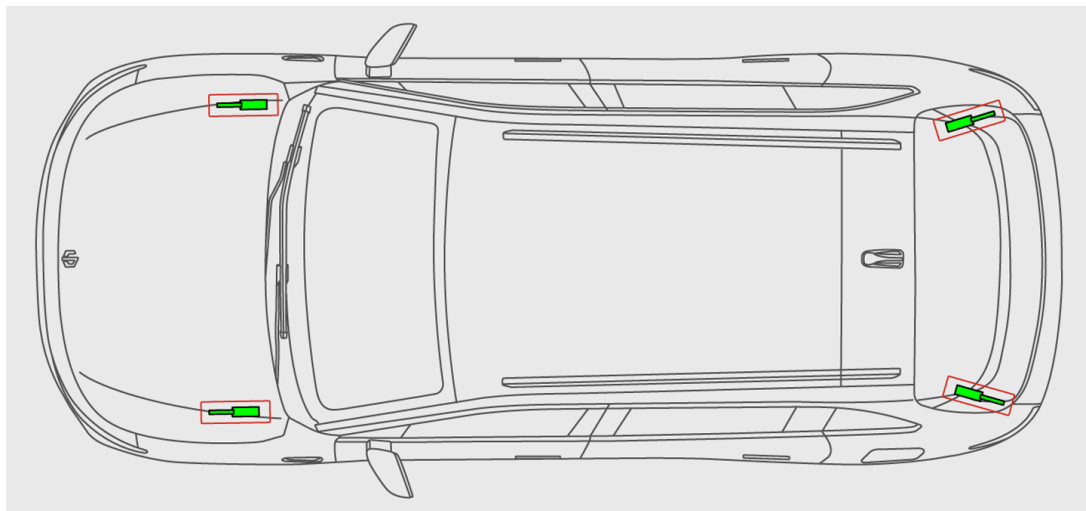

Leapmotor recommends using a thermal imager or infrared (TIC or IR) to monitor the battery temperature during the cooling process.

Use typical vehicle fire-fighting procedures to extinguish small fires that do not involve the traction battery.

During the extinguishing process, do not touch high-voltage components. Insulating tools should be used when extinguishing fires.



Heat and flame can endanger the airbag inflator, gas storage cylinders, gas spring, and other components that may accidentally overheat, leading to cylinder explosions.



## Use thermal infrared camera

After all flames and smoke are significantly weakened, a thermal imaging camera can be used to actively measure the temperature of the traction battery and monitor the heating or cooling trend. The vehicle can only be handed over to the second responder (e.g. law enforcement, vehicle transport personnel, etc.) after the traction battery has been without fire, smoke, or heat for at least one hour. Before handing over the vehicle to the second responder or leaving the accident scene, the battery must be completely cooled down. Be sure to inform the second responder of the reignition risk of the traction battery.

Damaged Leapmotor C10 power batteries in flooding, fire, or collision should be stored in an open area at least 50ft (15m) away from any exposed materials due to the potential for reignition.



In the event of a fire, assume the entire vehicle is energized. Be sure to wear full personal protective equipment, including a self-contained breathing apparatus.

## Traction battery - fire damage

Both the traction battery and the drive motor are liquid-cooled using a coolant. Do not touch the liquid leaking from the traction battery (if any).



Damaged traction battery can cause the battery unit to heat up quickly. If there are smoke, steam, or popping or hissing sounds coming from the traction battery, assume that the battery is heating up and take appropriate measures as mentioned above.



Burning batteries can release overheated gases and toxic vapours. This may include volatile organic compounds, hydrogen gas, carbon dioxide, carbon monoxide, soot, and particles containing nickel, aluminium, lithium, copper, cobalt, and hydrofluoric acid. Emergency personnel should always use full personal protective equipment (including SCBA) to protect themselves and take appropriate measures to protect civilians from the incident.

## 7. In case of submersion

The body of Leapmotor C10 poses a higher risk of electric shock when submerged in water. However, when dealing with any submerged vehicle, wear appropriate personal protective equipment for water rescue. Remove the vehicle from the water and safely disconnect the high-voltage power.

Due to the potential risk of traction battery fire, extra caution should be taken when dealing with submerged vehicles. Emergency personnel should be prepared to deal with the potential fire risk. Raise the front of the vehicle to allow water to drain from the vehicle and traction battery pack. After removing the vehicle from the water, continue with the normal high-voltage disable procedure as outlined in Chapter 3.



Be sure to wear full PPE. Handling a submerged vehicle without appropriate personal protective equipment may result in serious injury or death.

## 8. Towing / transportation / storage

The rear-mounted motor of Leapmotor C10 can generate power when the wheels are rotating. During transportation, all four tires must be off the ground. Ensure that the tires do not slip at any time during transportation.



Do not place the tires in a position where they can rotate during transportation. Doing so will result in serious damage and overheating. In rare cases, extreme overheating may cause surrounding components to catch fire.



Beware of battery reignition! After a fire, keep a safe distance outdoors from other vehicles and build-ings. (50ft/15m).

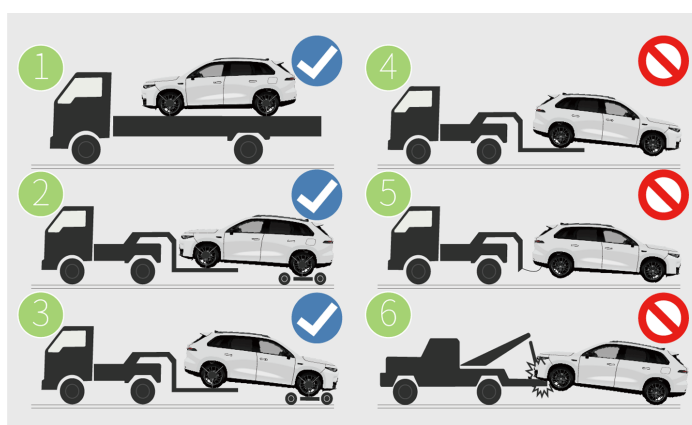

When the vehicle needs to be towed, it should be performed by a professional towing company. It is recommended to tow the vehicle with a flatbed truck. If the conditions are not sufficient, the vehicle can also be towed by a wheel-lifting cargo truck as needed.

Use the towing methods ① ② ③ shown in the picture, and do not use the dragging methods ④ ⑤ ⑥ shown in the picture. The towing methods ② ③ can only be used for straight-line towing or on road surfaces without sharp turns. During the towing process, no one is allowed to stay in the vehicle. For long-distance transportation, use towing method ①.

When the towing vehicle cannot enter for rescue, other vehicles can be used for towing rescue. Disconnect the high voltage of the vehicle, put the gear in N gear, and release the parking brake. The towing speed should be less than 30km/h, the towing distance should be less than 2km (the interval between each towing should be more than 5min). After the vehicle is towed to a position where the towing vehicle can be used, towing should be carried out using towing method ①.

If a flatbed truck cannot be used to tow the vehicle normally, the rigid connection method can be used to urgently tow the vehicle to a safe area and wait for rescue. When using rigid connection, long-distance towing should be avoided, and the towing speed should not exceed 5km/h. The vehicle can only be towed away from the scene under the premise of ensuring that there is no safety risk. If the battery pack of the vehicle is deformed, leaking, smoking, etc., the first step is to avoid safety risks.



The vehicle is equipped with high-voltage components that may be damaged in a collision. It is important to assume that these components are energized before transportation. Always follow high-voltage safety precautions (wear personal protective equipment, etc.) until emergency responders assess the vehicle and can accurately confirm that all high-voltage systems are de-energized. Failure to do so could result in serious injury.

## Car pushing



The following instructions are only for moving Leapmotor C10 a short distance to improve traffic safety. For more instructions on how to transport Leapmotor C10, please refer to the *User Manual* on the centre console display screen or delivered with the vehicle, damage caused during transportation is not covered by the warranty.



Pushing Leapmotor C10 while the vehicle is not in neutral gear may cause the drive motor to overheat and, if the electrical components are exposed, even if the emergency response circuit is cut off, may result in a potential risk of electric shock.

With minimal risk of fire or high-voltage exposure (e.g., vehicle not accelerating after stopping at an intersection) and a low voltage battery present, Leapmotor C10 can be pushed quickly to clear the road. If a driver is present, simply switch Leapmotor C10 to neutral gear and push it. If the driver is not present, Leapmotor C10 may automatically switch to the parking gear when it detects that the driver leaves the vehicle (even if it was previously in neutral gear).

## 9. Important additional information

This document contains important instructions and warnings that must be followed when handling Leapmotor C10 in emergency situations.



Always use appropriate rescue tools and wear proper PPE. Failure to follow these instructions may result in serious injury or death.



Beware of battery reignition! After a fire, keep a safe distance outdoors from other vehicles and buildings (50ft /15m).



After extinguishing a fire, the high-voltage circuit takes 2min to power off.



The supplemental restraint system control unit has a backup power supply that discharges in approximately 10s. Do not touch the supplemental restraint system control unit within 10s after the airbag or pretensioner deploys.



Handling a submerged vehicle without appropriate personal protective equipment may result in serious injury or death.



In the event of a fire, assume the entire vehicle is energized. Be sure to wear full PPE, including a self-contained breathing apparatus.



Regardless of the use of disabling procedures, always assume all high voltage components are energized! Cutting, crushing, or touching high voltage components may cause serious personal injury or death.



















Do not place the tires in a position where they can rotate during transportation. Doing so will result in serious damage and overheating. In rare cases, extreme overheating may cause surrounding components to catch fire.

### Contact information

Name of manufacturer: Leapmotor Automobile Co., Ltd

## 10. Explanation of pictograms used

	Use thermal infrared camera		Bonnet
	Boot		General warning sign
	Warning, Electricity		Flammable
	Explosive		Corrosive
	Hazardous to the human health		Acute toxicity
	Gases under pressure		Use water to extinguish the fire
	Seat height adjustment		Seat adjustment, longitudinal
	Steering wheel, tilt control		Air-conditioning component