

AUTOMATIC

Screw Gun & Feeder

REDEFINING AUTOMATED SCREWDRIVING

Our engineers have developed this product to streamline your manufacturing process, saving time and money. Our system includes the following features to give our customers the easiest, most efficient, and most reliable product on the market:

- ✔ *Most compact full-function driver package on the market*
- ✔ *High-end, commercially available components for high reliability*
- ✔ *Password protection on feeder controller parameters*
- ✔ *Plug and play solution*



SG125

Automated Screwdriver with
125mm stroke

M1000

Machine System with Quick
Change Fixture Mount and
Safety

FS12

Automated Feed and Control
System for 12mm - 16mm Long
Screws*

**Special Application Available Upon Request*

**GET A
QUOTE**

Contact our sales team to
discuss buying options and
customization to fit your
needs. Learn more at
www.protomachineworks.com

“

We are satisfied with the product...we have 5 step feeders...running 3 shifts 6 days [per week] without mistake.

The machine reaction is fantastic. I would highly recommend this step feeder.

-AUTOMOTIVE INDUSTRY SME

”

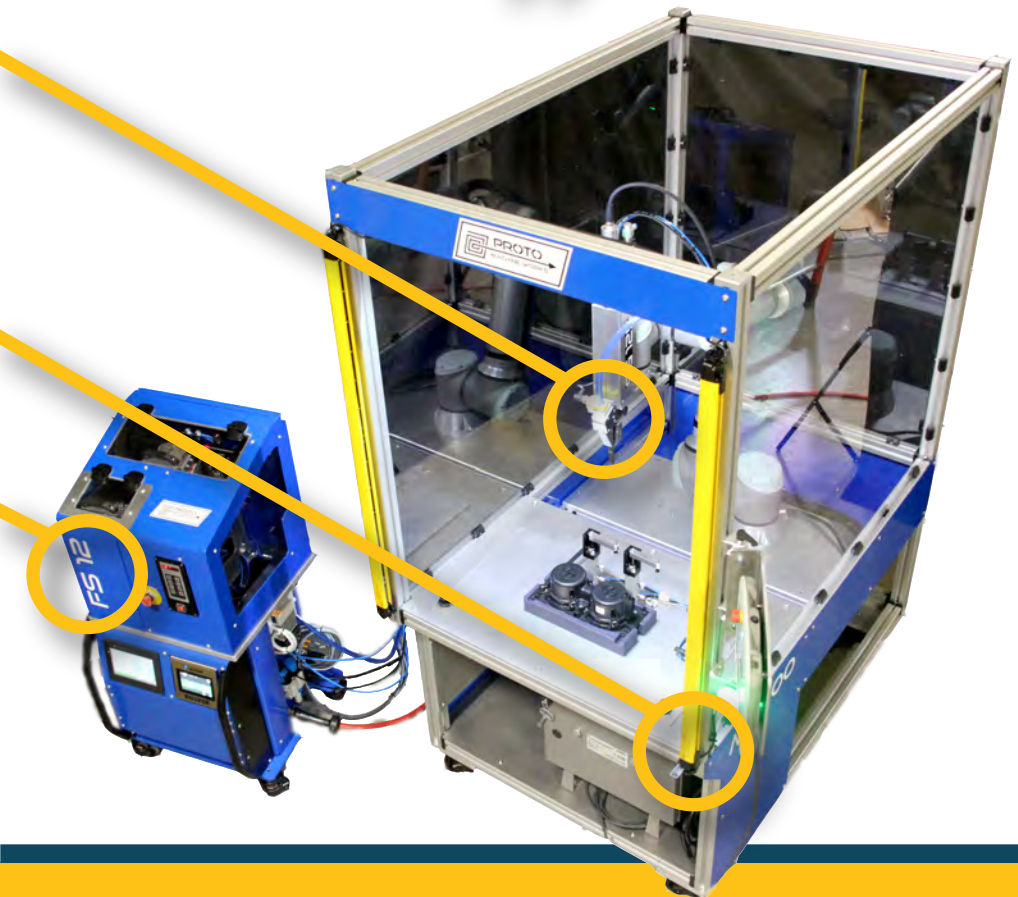

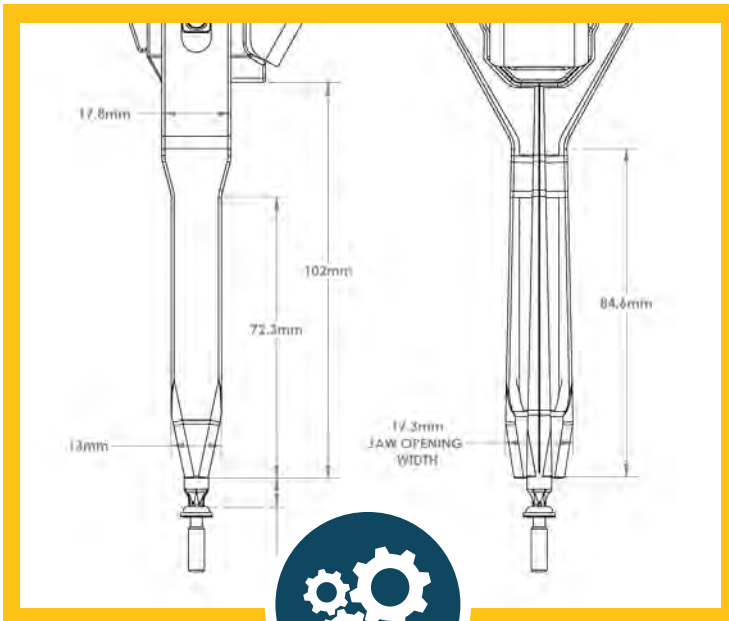

SCREW DRIVER SG 125

- **Torque Range:** 0.5 Nm (4.42 in-lbs) to 6.0 Nm (53 in-lbs)
- **Torque Monitor:** Precision Transducer
- **Screw Head Diameter:** 8mm to 9mm
- **Screw Length Under Head:** 12mm to 16mm
- **Speed:** 50 rpm to 850 rpm
- **Weight:** 5.5 kg (12.13 lb)
- **Dimensions:** 727mm by 225mm by 105mm

SYSTEM CONTROLLER & FEEDER FS 12

- **Typical Feed Rate:** 3 sec/screw
- **Screw Hopper Volume:** 1500 cc
- **Dimensions:** 575mm by 610mm by 1200mm
- **Power:** 120VAC/15A
- **Weight:** 140 kg (310 lbs)



3401 Stanwood Blvd NE
Huntsville, AL 35811



info@protomachineworks.com



256-355-0800