

HYBRID AM

AtranVelo AB
Vinbergsvägen 4
311 50 Falkenberg
info@atranvelo.com

10kg
Max load

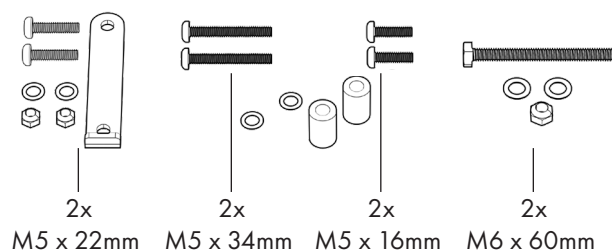
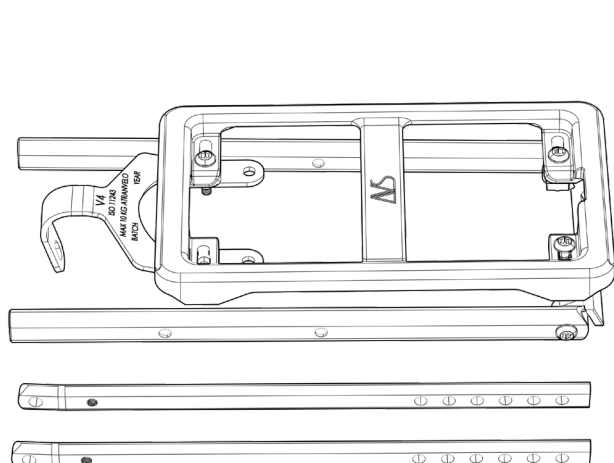
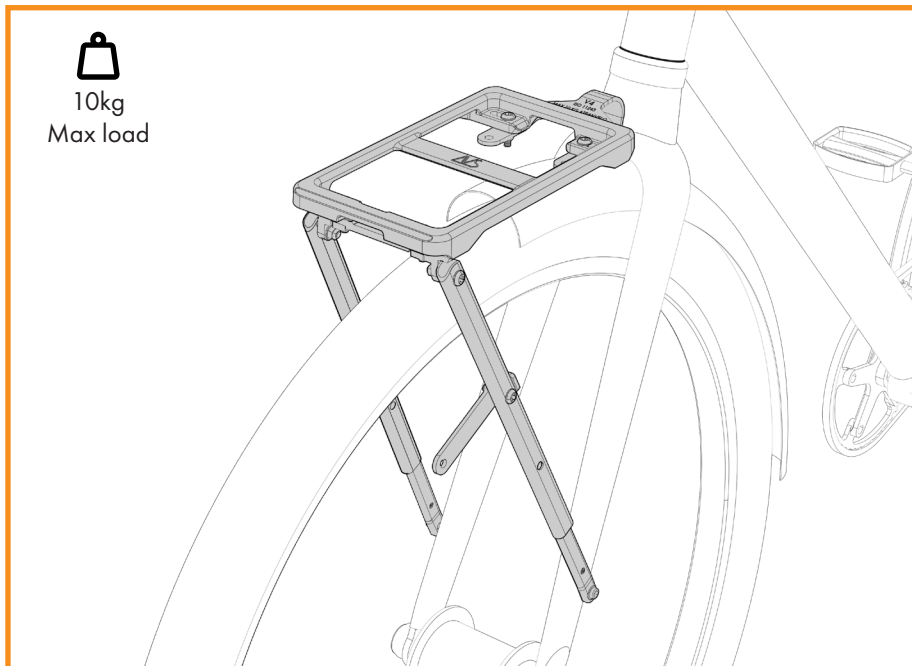

- Fork attachment
M6 x 60mm
- Mounting point with spacer
2x M5 x 34mm
- Mounting point
2x M5 x 16mm
- Adjustable legs
2x M5 x 22mm

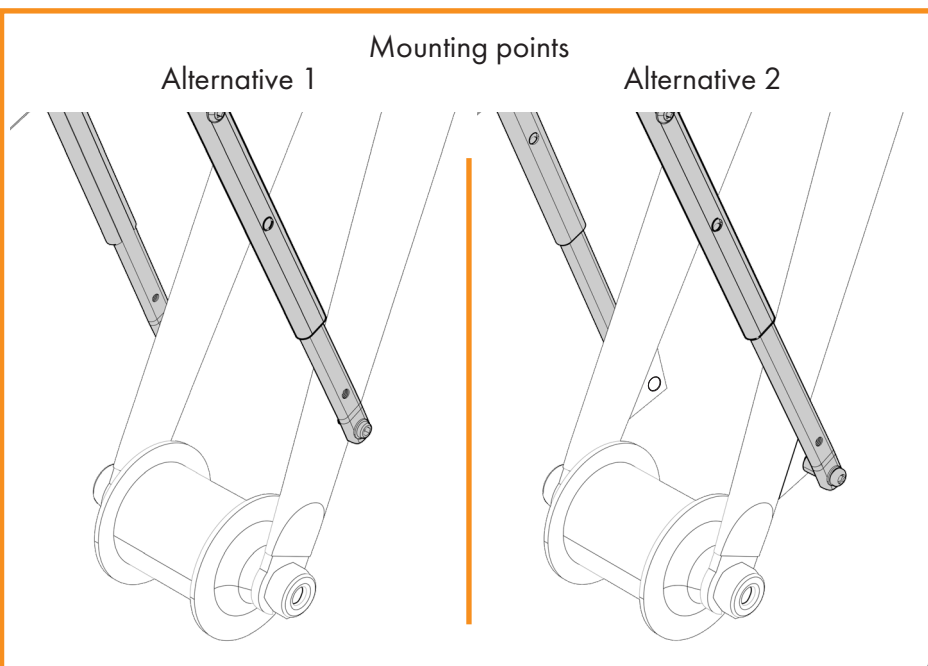
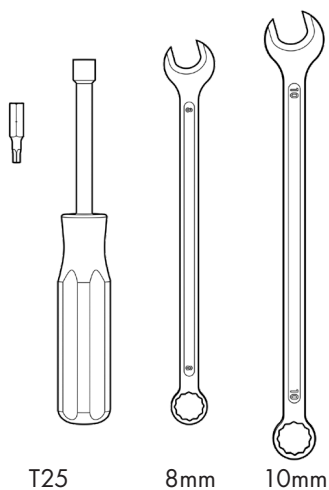

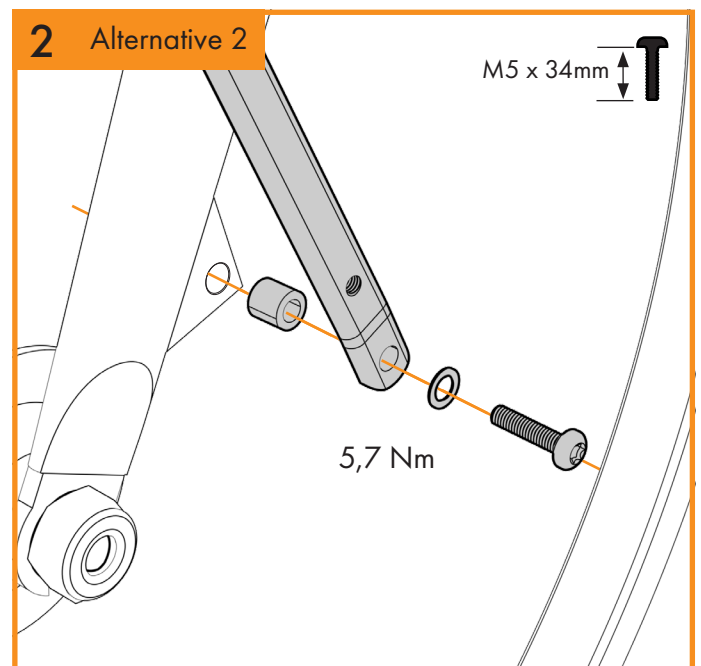
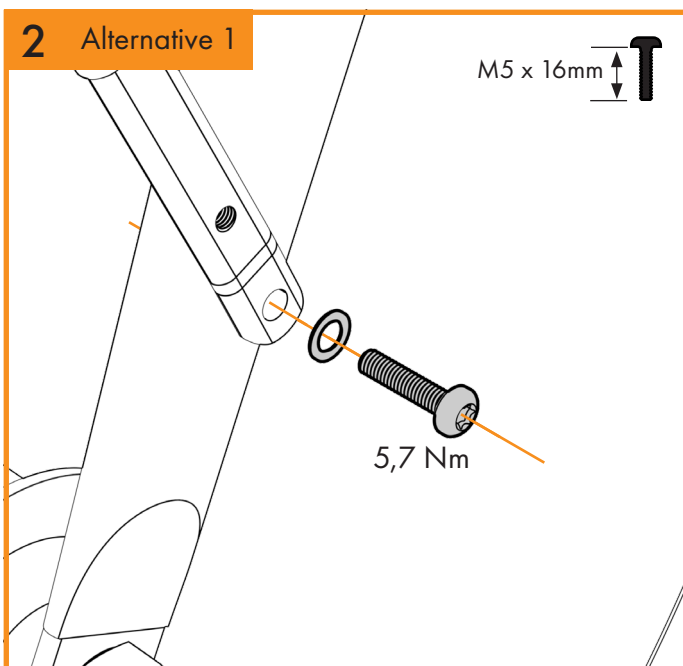
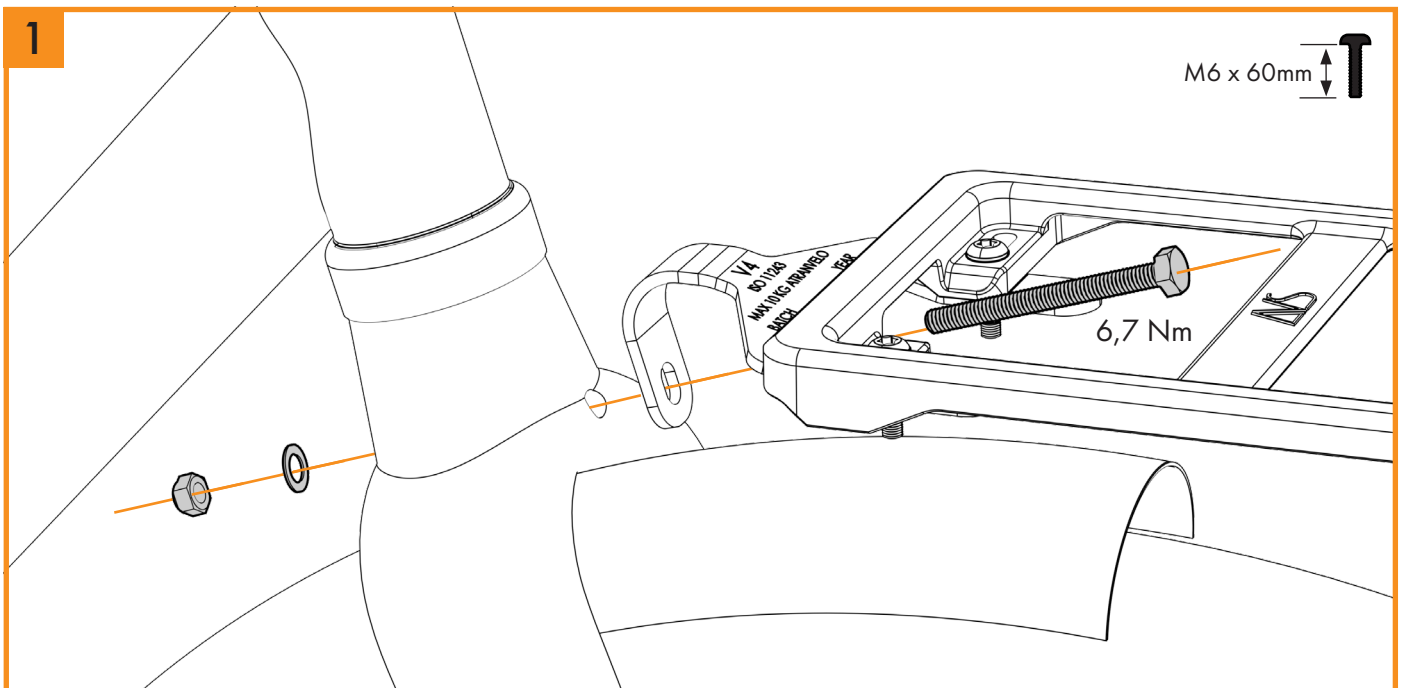
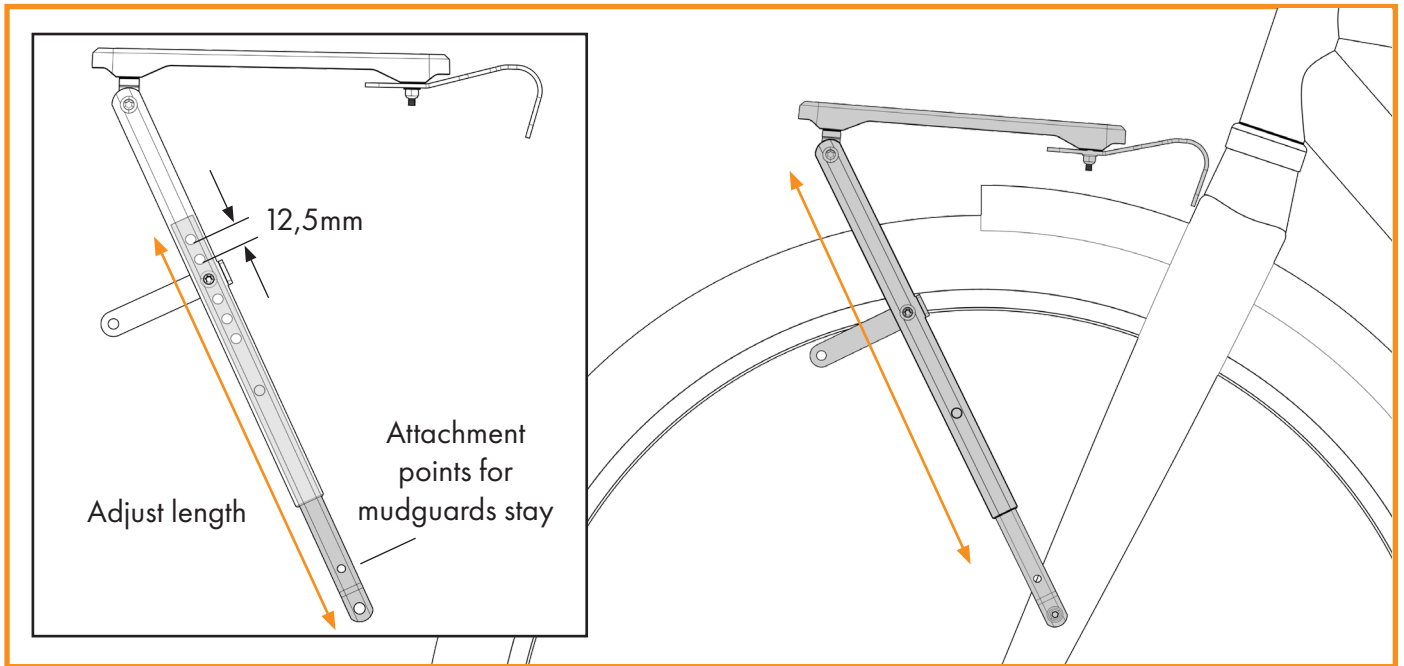

3

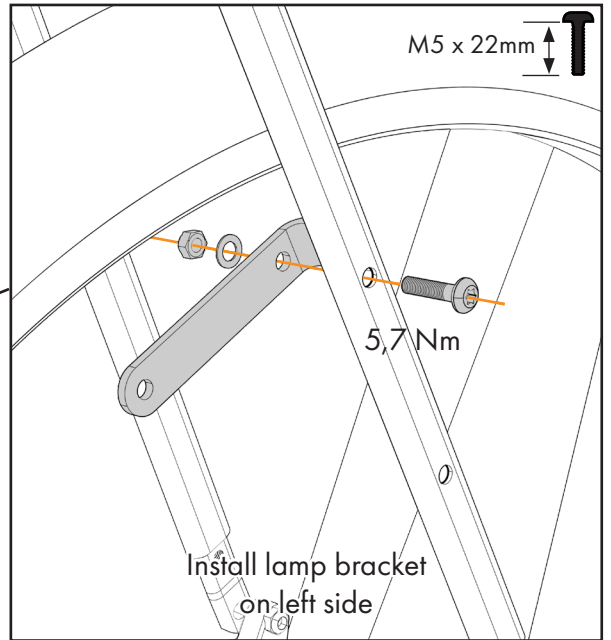
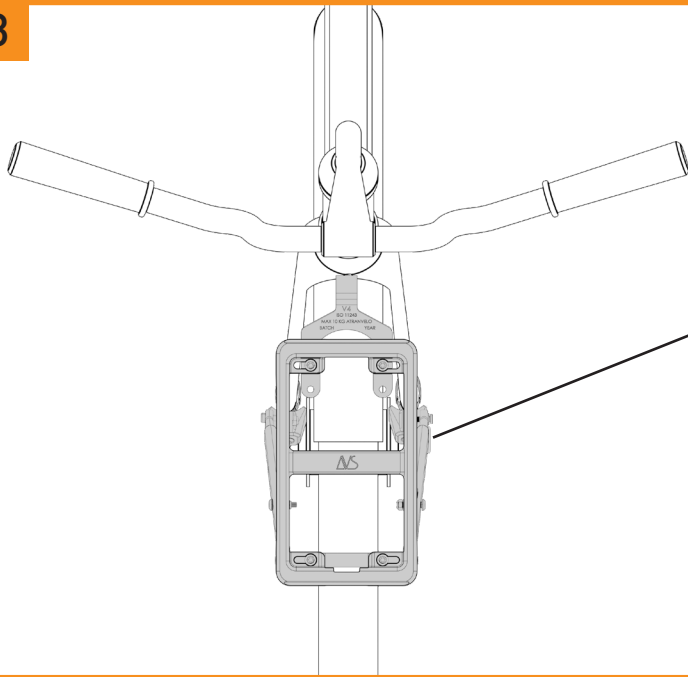

4

Tighten all screws

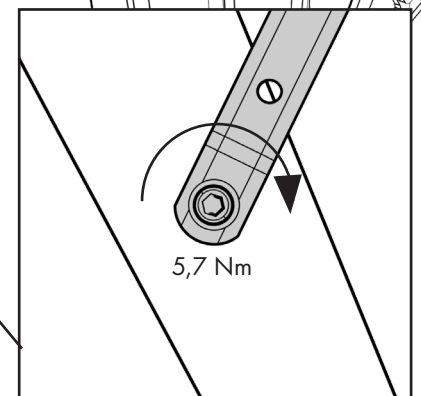
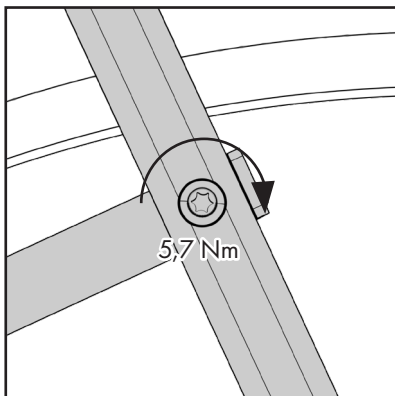
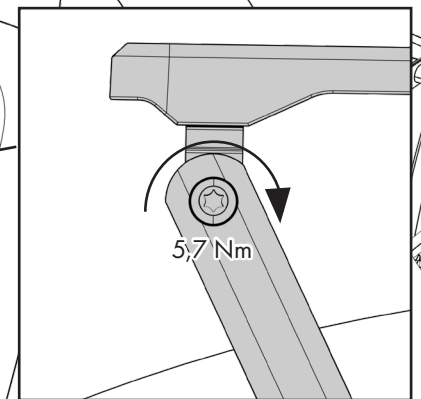
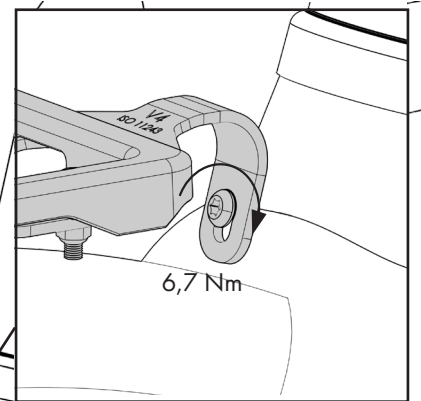
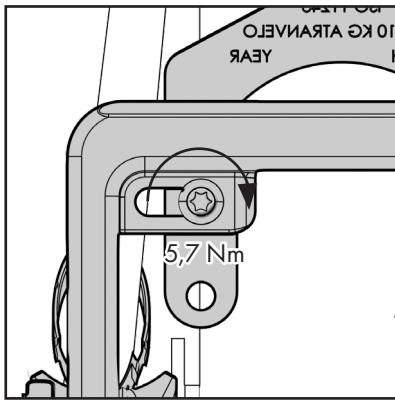

The instruction shall be read and understood before the use of HYBRID AM.

Keep the instructions so you can return if necessary.

Model: HYBRID UNI 20"-29"

WARNING: Check the geometric data and the strength of the bicycle, on which the HYBRID UNI is to be mounted, are compatible with the HYBRID UNI specification. Contact your dealer where the bicycle was bought for help if you are unsure.

Read and follow the assembly instructions/routines carefully before starting installation. Recommended tightening torque for the fasteners shall be followed, according to the assembly instructions. If no recommended torque is listed, ISO 898/1 shall be followed. **WARNING,** the fasteners supplied or recommended to be used, shall not be replaced or changed. This includes all screws, nuts, washer, braces and/or brackets.

The maximum load capacity of this HYBRID UNI is 10 kg.

Under no circumstances shall the maximum load capacity be exceeded.

The HYBRID UNI and associated fasteners should be checked regularly. The slightest sign of deviation shall be corrected immediately. Contact the dealer where the bicycle was purchased for a proper review and possible action.

Right loaded, this HYBRID UNI is a safe way to transport luggage in traffic. Check that there are no loose straps or pieces of luggage that can come down on/to the wheel while driving.

Under no circumstances shall this HYBRID UNI be changed or modified.

WARNING: The bike behaves differently when luggage is loaded on the HYBRID UNI. Always distribute the weight as evenly as possible on the carrier. Test ride the bicycle in a safe location before heading out into the traffic. Be aware that special steering and braking are affected when the HYBRID UNI is loaded.

WARNING: before you start riding the bicycle, ensure that any luggage fitted to the HYBRID UNI is properly secured in accordance with the manufacturer's instructions and that there are no loose straps or similar, that can get caught in the wheel.

Lamps and reflectors should be mounted in the designated location in front of the HYBRID UNI. Check that the lamp and/or the reflex is approved in the country you riding the bicycle in. Before riding the bike, make sure that the luggage does not obscure the lights and/or reflectors.

Always distribute the luggage as evenly as possible on the HYBRID UNI. Remember not to exceed the maximum load capacity.

The maximum compatible size for the HYBRID UNI is between 20" – 29". Even if there is a specified size listed, problems may arise depending on the geometry of your bicycle. If you are unsure about the fit, contact your bicycle dealer for a professional assessment.

The type(s) of bicycles for which this HYBRID UNI are intended, is a vehicle that has at least two wheels and is propelled solely or mainly by the muscular energy of the person on that vehicle, in particular by means of pedals, or a equipped with pedals and an auxiliary electric motor, which cannot be propelled exclusively by means of this auxiliary electric motor, except in the start-up assistance mode.