

User Manual



H3/AC3 Smart & H3-M & P3 S Series Storage Inverter

H3 5.0~15.0-Smart

AC3 5.0~15.0-Smart

H3 5.0~15.0-M

P3 5.0~15.0-SH

To prevent damage to the product caused by improper use, please carefully read this manual before operation.

Copyright © FOXESS Co., Ltd. All rights reserved.

No part of this document may be reproduced, copied, or distributed in any form or by any means without prior written authorization from the company.

Trademarks



and other Fox ESS trademarks are the property of FOXESS Co., Ltd.

All other trademarks or registered trademarks mentioned in this document belong to their respective owners.

Software License

Commercial use of any part or all of the firmware or software developed by the company is strictly prohibited.

Reverse engineering, decompilation, or any other actions that destroy the original design of the company's software are prohibited.

This document is intended as a usage guide only. All statements, information, and recommendations herein do not constitute any warranty, express or implied.

Due to product version updates or other reasons, the content of this document may be updated periodically. Please download the latest version from the official website if needed.

FOXESS Co., Ltd

Add:

No.939, Jinhai Third Road, New Airport Industry Area, Longwan District, Wenzhou, Zhejiang, China

Tel: 0510- 68092998

Postcode: 325024

WWW.FOX-ESS.COM

Version V1.0.0

Date 2025-09

Contents

1	Notes on This Manual	1
1.1	Scope of Validity	1
1.2	Target Group	1
1.3	Symbols Used	1
2	Safety Precautions	5
2.1	Personnel Safety	5
2.2	Electrical connection safety	6
2.3	Installation Requirements	8
2.4	PE Connection and Leakage Current	10
3	Product Introduction	12
3.1	Basic Features	12
3.2	Dimensions	15
3.3	Terminals of inverter	15
4	Technical Data	16
4.1	PV Input (For H3-Smart Only)	16
4.2	Battery	17
4.3	AC Output/Input	17
4.4	EPS Output	18
4.5	Efficiency and Protection	19
4.6	General Data	20
5	Installation	21
5.1	Installation Precautions	21
5.2	Unpackaging	21
5.3	Installation Requirements	23
5.4	Tools Preparation	27
5.5	Inverter Handling	27
5.6	Installation Steps	28
6	Electrical Connection	31
6.1	Connection Overview	31
6.2	PV Connection (For H3-M/H3-Smart Only)	32
6.3	Battery Connection	35
6.4	Grid Connection	37
6.5	Earth Connection	38

6.6 Installation Instructions	39
6.7 Installation steps for 5-core wire	40
6.8 RJ45 connection	43
6.9 Antenna Connection	45
6.10 COM connection	46
6.11 Electrical Connection	49
6.12 EPS Connection (Non-parallel State)	58
6.13 System Connection Diagrams	58
6.14 Inverter Start-Up	59
6.15 Inverter Switch Off	59
7 Main function implementation	60
7.1 Drm wiring	60
7.2 RCR wiring	61
7.3 SG ready wiring and setting	63
7.4 Reactive Function Setting	65
7.5 Implementation of dual-channel EPS function	69
7.6 Parallel connection wiring and operating instructions	70
8 Firmware Upgrading	83
9 Operation	88
9.1 Control Panel	88
9.2 Function Tree	89
10 Maintenance	90
10.1 Alarm List	90
10.2 Troubleshooting and Routine Maintenance	95
11 Inverter Storage and Disposal	96
11.1 Disassembling the Inverter	96
11.2 Storing the Inverter	96
11.3 Transporting the Inverter	96
11.4 Decommissioning/Scrapping the Inverter	96
12 Appendix	97
12.1 Quality Guarantee	97
12.2 Contact Us	98

1 Notes on This Manual

Hybrid series inverters are designed and tested in accordance with international safety requirements. Certain safety precautions must be taken when installing and operating this inverter. The installer must read and follow all instructions, cautions and warnings in this installation manual.

1.1 Scope of Validity

This manual describes the assembly, installation, commissioning, maintenance and troubleshooting of the following model(s) of products:

H3-5.0-Smart	H3-6.0-Smart	H3-8.0-Smart	H3-9.9-Smart		
H3-10.0-Smart	H3-12.0-Smart	H3-15.0-Smart			
AC3-5.0-Smart	AC3-6.0-Smart	AC3-8.0-Smart	AC3-9.9-Smart		
AC3-10.0-Smart	AC3-12.0-Smart	AC3-15.0-Smart			
H3-5.0-M	H3-6.0-M	H3-8.0-M	H3-10.0-M	H3-12.0-M	H3-15.0-M
P3-5.0-SH	P3-6.0-SH	P3-8.0-SH	P3-10.0-SH1	P3-10.0-SH	P3-12.0-SH
P3-15.0-SH					

Please keep this manual where it will be accessible at all times.

1.2 Target Group

This manual is intended for use by qualified electricians only. All procedures described herein shall be performed by trained and experienced electrical personnel in compliance with basic electrical safety requirements.

1.3 Symbols Used

The following symbols are used in the manual to highlight information in order to ensure the safety of the user's person and property when using the product, and to use the product more efficiently and optimally. The following symbols may appear in this manual, and the meanings they represent are listed below:

Danger!

"Danger" indicates a hazardous situation which, if not avoided, will result in death or serious injury.

Warning!

“Warning” indicates a hazardous situation which, if not avoided, could result in minor or moderate injury.

Note!

“Note” provides important tips and guidance.

⚠ Danger!

The PV string will generate lethal high voltage when exposed to sunlight.

Operators must wear proper personal protective equipment during electrical connections.

Must ensure that cables are voltage-free with a measuring instrument before touching Dc cables.

Respect all safety instructions listed in relevant documents about PV strings.

⚠ Danger!

Before electrical connections, please make sure that the inverter switch and all switches connected to the inverter are set to "OFF", otherwise electric shock may occur!

Ensure that the inverter is undamaged and all cables are voltage free before performing electrical work. Do not close the Ac circuit breaker until the electrical connection is complete.

⚠ Warning!

Damage to the product caused by incorrect wiring is not covered by the warranty.

Electrical connection must be performed by professionals.

Operators must wear proper personal protective equipment during electrical connections.

All cables used in the PV generation system must be firmly attached, properly insulated, and adequately dimensioned.

⚠ Danger!

The PV string will generate lethal high voltage when exposed to sunlight.

Respect all safety instructions listed in relevant documents about PV strings.

⚠ Warning!

Make sure the PV array is well insulated to ground before connecting it to the inverter.

Make sure the maximum DC voltage and the maximum short circuit current of any string never exceed inverter permitted values specified in "Technical Data" Check the positive and negative polarity of the PV strings, and connect the PV connectors to

corresponding terminals only after ensuring polarity correctness.

During the installation and operation of the inverter, please ensure that the positive or negative electrodes of PV strings do not short-circuit to the ground. Otherwise, an AC or DC short-circuit may occur, resulting in equipment damage. The damage caused by this is not covered by the warranty.











Electric arc or contactor over-temperature may occur if the PV connectors are not firmly in place, and Fox shall not be held liable for any damage caused.

If the Dc input cables are reversely connected and the Dc switch has been rotated to "ON", do not operate immediately. Otherwise, the inverter may be damaged. Please turn the Dc switch to "OFF" and remove the Dc connector to adjust the polarity of the strings when the string current is lower than 0.5 A.

 **Warning!**

Before connecting the PV array to the inverter, ensure that the impedances between the positive terminals of the PV string and earth, and between the negative terminals of the PV string and earth are larger than 1 M Ohm.

This section explains the symbols shown on the inverter and on the type label:

Symbols	Explanation
	CE mark. The product complies with the relevant EU directives.
	RCM mark.
	RoHS mark.
	Beware of hot surface. The inverter can become hot during operation. Avoid contact during operation.
	Danger of high voltages. Danger to life due to high voltages in the inverter!
	Hazards, warnings and cautions. Important safety information regarding personal safety. Failure to follow the safety information in this manual could result in injury or even death.
	Capacitor discharge. Before opening the cover, the inverter must be disconnected from the grid and the PV string. Wait at least 15 minutes for the storage capacitors to discharge completely.
	Read the manual before performing any operations on the inverter.
	Product should not be disposed as household waste.
	PE conductor terminal.

2 Safety Precautions

2.1 Personnel Safety

Danger!

Operating Requirements

- High voltage exists inside the equipment. Unauthorized removal of necessary protective measures, improper use, and improper installation and operation may cause serious safety hazards, shock hazards, or equipment damage, and the resulting damage to the equipment is not covered by the warranty.
- Do not energize the equipment without completing the installation or without professional confirmation, and strictly prohibit operation with electricity.

Warning!

Operating Requirements

- Always use special insulated tools for wiring operations. Direct contact or contact with other conductors or indirect contact with the power supply equipment through wet objects is prohibited.
- During operation of the equipment, the enclosure temperature is high and there is a risk of burns. Before touching any part of the inverter, make sure that the equipment and its surfaces are at a contact-safe temperature and voltage before proceeding.

Note!

Personnel requirements

- All operations, including transportation, installation, start-up and maintenance, must be performed by qualified and trained personnel.
- Before operating the equipment, be sure to check that it is in proper condition, including, but not limited to, the equipment's parts, safety devices, and meter display.
- If any abnormality is found during operation, do not use the inverter and avoid temporary maintenance of the inverter.
- Special scenario operators, such as electrical operation, high place operation, equipment maintenance operation, etc., must have special operation qualification that meets the requirements of the local country/region, and should comply with local standards and relevant safety codes.
- Strictly follow the safety operation procedures, understand the potential dangers in equipment operation, and take precautions to maximize the safety of themselves and related personnel to prevent accidents caused by improper operation.
- Operators are required to wear appropriate personal protective equipment, including protective clothing, gloves, goggles, and helmets.
- It is strictly prohibited to operate under fatigue, drunkenness, or ill health.
- Take extra care when the inverter is disconnected from the public grid, as certain components may hold a certain voltage, creating a risk of electric shock.
- Before installation, check the machine to make sure that it does not have any damage caused by transportation or handling processes that could affect the insulation or safety distances. Choose the installation location carefully and observe

Hybrid Series Storage Inverter

the specified cooling requirements.

- Before connecting the inverter to the distribution grid, contact the local distribution grid company for approval. This connection must be carried out by a qualified technician.
- Do not use the equipment when the safety devices do not work or are disabled.
- The manufacturer needs to be notified of any non-standard installation conditions.
- All repairs should be carried out only with approved spare parts, which must be installed in accordance with their purpose and by an authorized contractor or an authorized service representative.

2.2 Electrical connection safety

Danger!

Operating Requirements

- Remove all electrical connections from the unit before making electrical connections.
- Before making electrical connections, it is important to verify that the equipment itself and its front and rear switches are disconnected and that reliable locking and marking measures are in place to prevent accidental energization.

Wiring Requirements

- No loads may be connected between the inverter and its directly connected AC circuit breaker.
- Use test equipment to ensure that the PV strings have the correct positive and negative terminals.
- The entire grounding system should remain intact, including the grounding electrode, grounding trunk, branch wires, and connections to the equipment.

Grounding Requirements

- The protective earth conductor needs to remain grounded during installation and when removing the equipment.

Maintenance Requirements

- High voltage exists inside the unit, do not open the unit's mainframe panel.
- Disconnect the corresponding output switch of the power supply unit before performing maintenance on the power supply unit's back-end electricity or power distribution equipment.

Warning!

Wiring Requirements

- In electrical installations, it is important to follow the relevant codes and standards and to use circuit breakers of appropriate specifications to protect the safety of the circuit.

Grounding Requirements

- The grounding resistance should be in accordance with relevant standards and regulations to ensure effective current discharge. Normally, the value of grounding resistance should be small enough to ensure that the current can be quickly directed to earth in the event of a fault.

Maintenance Requirements

- Always use measuring equipment to ensure that the equipment is at contact-safe temperatures and voltages before touching any parts, and wear protective equipment for operation and maintenance of the inverter.

Note!

Wiring Requirements

- Wires should be secured and supported at appropriate locations to prevent dislodgement or damage due to self-weight or external forces.

Inspection before connection

- Check the appearance and structure of the equipment for damage, whether the equipment received and the actual equipment ordered are the same, and contact Fox ESS in case of doubt, connecting damaged equipment can cause the risk of fire and electric shock.

Wiring Requirements

- Cable slots and crossing holes should have no sharp edges and the location of the pipe or crossing holes should be protected to prevent damage to the cables.

- Strictly follow national and industry standards and codes for electrical wiring for construction and installation.
- Verify that tools and test equipment used are functioning properly, calibrated effectively, and meet safety standards, and check and register the number of tools to prevent them from being left inside the equipment.
- Check that markings and labels on wires, terminals and equipment are clear and accurate.
- Check that connecting terminals are well insulated and protected, free from corrosion, deformation or looseness.
- Incorrect wiring operations can cause accidents such as fire or electric shock, and the resulting damage will not be covered by the warranty.
- Wiring should be clearly labeled to facilitate maintenance and troubleshooting.
- Wiring personnel need to wear appropriate personal protective equipment and use professional insulated tools for operation .
- The grounding system should be tested regularly to check the grounding resistance, connection status, etc. Before operating the equipment, ensure that the equipment is reliably grounded, and find and repair any damage or abnormality in time.
- Cabling should be kept at a safe distance of at least 30mm from high temperature heat sources to prevent aging of the insulation.
- Cables should not block the air inlet and outlet of the equipment.
- After the connection is completed, it should be ensured that the insulation of the wires is restored intact and the exposed conductor parts are effectively insulated.
- The grounded portion should be clearly labeled to alert personnel.
- The grounding connection must be firm and reliable to avoid loose, corrosion, or poor contact. The connection shall be properly treated against corrosion.
- Wiring should be laid neatly and in an orderly manner, avoiding crossings, tangles and excessive bending to minimize the risk of damage to the wires. Select power cords of sufficient length and strictly prohibit making joints or soldering points in power cords.
- The insulation of wires and cables should be intact and have good insulation properties to effectively prevent leakage and short circuit.

Hybrid Series Storage Inverter

- The same kind of cables are tied neatly without outer skin damage, and different kinds of cables are laid out separately, forbidding twisting and crossing.
- Regularly check the system parameters and make records, if anomalies are found, the causes should be identified and dealt with accordingly. If you can not determine the cause of the anomaly, you need to turn to professionals to avoid accidents affecting the use of the system.
- Non-professionals are not allowed to disassemble and overhaul the inverter without authorization, and the operators need to be specially trained.
- Strictly follow the use and maintenance instructions of the product to operate, make sure the warning signs are intact, and replace the signs that become unclear due to long-term use in time.
- Regularly check whether the wiring and connecting terminals of each part of the equipment are firm and whether there is any looseness; especially pay attention to the fan, power module, input terminals, output terminals, grounding, and other parts.
- Place eye-catching warning signs or set up safety warning belts around the products; non-staff are not allowed to enter to avoid mishandling or accidents after unrelated personnel approach the products.
- Hang a "Danger - Do Not Close" tag on the upstream and downstream switches or circuit breakers, and post warning signs to prevent accidental connection.

2.3 Installation Requirements

Danger!

Equipment Protection

- Strictly follow the operation manual and specifications of the equipment to carry out maintenance operations, do not carry out other maintenance operations beyond this manual without authorization to avoid equipment failure due to incorrect operation.
- Prohibit arc welding, drilling, cutting and other operations on the equipment, and prohibit the installation of other equipment on the top of the product.

Drilling Safety

- Avoid pre-buried pipes or lines when drilling to avoid short circuits or other hazards.
- The entire grounding system should be kept intact, including the grounding electrode, grounding trunk, branch lines, and connections to the equipment.
- In electrical installations, it is important to follow the relevant codes and standards and to use circuit breakers of the right size to protect the safety of the circuits.

Note!

Use of Tools

- All tools must be complete, properly certified, and within their inspection validity period. Before use, ensure that the tools are sturdy and free from damage, loose parts, or missing components.

Equipment Protection

- Paint scratches, drops or rust stains that occur during transportation and installation of equipment must be repaired in a timely manner, and long-term exposure of the scratched part may affect the use of the inverter.

Drilling Safety

Hybrid Series Storage Inverter

- Appropriate protective equipment such as goggles, earplugs, helmets, and coveralls should be worn when drilling to prevent splashing debris from hurting eyes and face, reduce noise damage to hearing, and protect the body from injury.
 - Cabling should be kept at a safe distance of at least 30 mm from high temperature heat sources to prevent deterioration of the insulation.
 - Cables should not block the air inlet or outlet of the equipment.
-
- Ensure that there is enough space and good lighting, and avoid using tools in dangerous or unstable environments.
 - Use the tool correctly and operate the tool correctly according to the instruction manual or professional guidance on the correct way to use the tool.
 - Perform regular maintenance, such as cleaning, lubrication, and calibration, to extend the service life of the tools and maintain their performance.
 - Before operation, dust, dirt, and debris need to be removed from the surface of the equipment to prevent them from entering the interior of the equipment and causing damage.
 - Update the operating system and related software of the equipment in time to fix the loopholes and improve the performance.
 - Protect the equipment from external collision and strong vibration.
 - Obtain consent from customers and contractors before drilling.
 - Check the drilling equipment before use, including whether the drill is securely installed, whether the wires are broken, and whether the switch is normal.
 - Ensure that the workpiece being drilled is securely fastened to prevent it from moving or rotating during drilling.
 - When replacing drills, cleaning debris or performing equipment maintenance, strictly prevent debris from falling into the interior of the equipment, and be sure to stop the machine first and then clean up the debris in a timely manner.

2.4 PE Connection and Leakage Current

PV System Residual Current Factors

- In every PV installation, several elements contribute to the current leakage to protective earth (PE). these elements can be divided into two main types.
- Capacitive discharge current - Discharge current is generated mainly by the parasitic capacitance of the PV modules to PE. The module type, the environmental conditions (rain, humidity) and even the distance of the modules from the roof can effect the discharge current. Other factors that may contribute to the parasitic capacitance are the inverter's internal capacitance to PE and external protection elements such as lightning protection.
- During operation, the DC bus is connected to the alternating current grid via the inverter. Thus, a portion of the alternating voltage amplitude arrives at the DC bus. The fluctuating voltage constantly changes the charge state of the parasitic PV capacitor (i.e capacitance to PE). This is associated with a displacement current, which is proportional to the capacitance and the applied voltage amplitude.
- Residual current - if there is a fault, such as defective insulation, where an energized cable comes into contact with a grounded person, an additional current flows, known as a residual current.

Residual Current Device (RCMU)

- All inverters incorporate a certified internal RCMU (Residual current monitoring unit) to protect against possible electrocution in case of a malfunction of the PV array, cables or inverter (DC). The RCMU in the inverter can detect leakage on the DC side. There are 2 trip thresholds for the RCMU as required by the DIN VDE 0126-1-1 standard. A low threshold is used to protect against rapid changes in leakage typical of direct contact by people. A higher threshold is used for slowly rising leakage currents, to limit the current in grounding conductors for the safety. The default value for higher speed personal protection is 30mA, and 300mA per unit for lower speed fire safety.

Installation and Selection of an External RCD device

- An external RCD is required in some countries. The installer must check which type of RCD is required by the specific local electric codes. Installation of an RCD must always be conducted in accordance with local codes and standards. recommends the use of a type-A RCD. Unless a lower value is required by the specific local electric

codes, suggest choosing a 300mA RCD.

- In installations where the local electric code requires an RCD with a lower leakage setting, the discharge current might result in nuisance tripping of the external RCD. The following steps are recommended to avoid nuisance tripping of the external RCD:
- Selecting the appropriate RCD is important for correct operation of the installation. An RCD with a rating of 30mA may trip at a leakage as 15mA (according to IEC 61008). High quality RCDs will typically trip at a value closer to their rating.

3 Product Introduction

3.1 Basic Features

Hybrid series are high-quality inverters which can convert solar energy to AC energy and store energy into battery. The inverter can be used to optimize self-consumption, store in the battery for future use or feed-in to public grid. Work mode depends on PV energy and user's preference.

Advantages	
	<ul style="list-style-type: none"> ✓ Advanced DSP control technology. ✓ Utilizes the latest high-efficiency power component. ✓ Utilizes the latest high-efficiency power component. ✓ Advanced anti-islanding solutions. ✓ IP65 protection level. ✓ Max. Efficiency up to 98%; EU efficiency up to 97.3%; THD<3%. ✓ Safety & Reliability: Transformerless design with software and hardware protection. ✓ Export limitation (CT/Meter/DRM0/ESTOP). ✓ Power factor regulation. ✓ Friendly HMI. ✓ LED status indications. ✓ LCD display technical data, human-machine interaction through four touch keys. ✓ PC remote control.

System connection diagrams

Note!

According to Australian safety requirements, the neutral cables of the on-grid side and backup side must be connected together. Otherwise, the backup function will not work.

- This diagram is an example for an application that neutral connects with the PE in a distribution box.
- For countries such as Australia, New Zealand, South Africa, etc, please follow local wiring regulations.

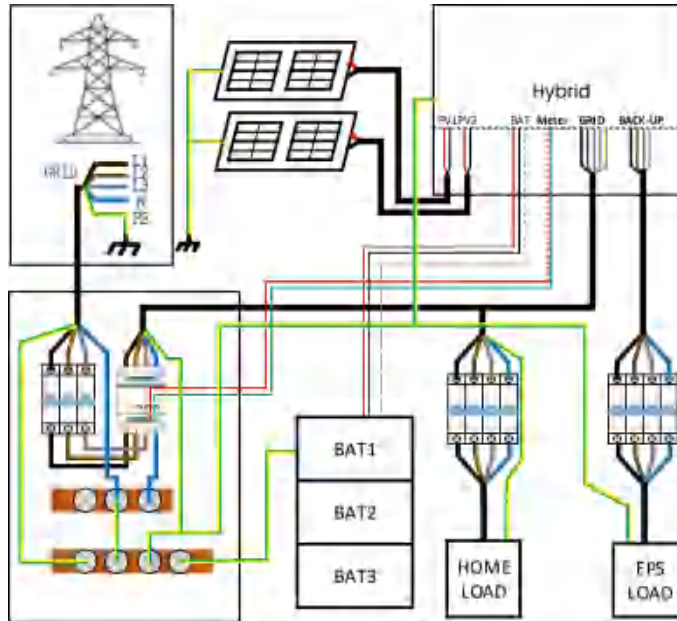

This diagram is an example for an application in which neutral is separated from the PE in the distribution box.

For countries such as China, Germany, the Czech Republic, Italy, etc, please follow local wiring regulations.

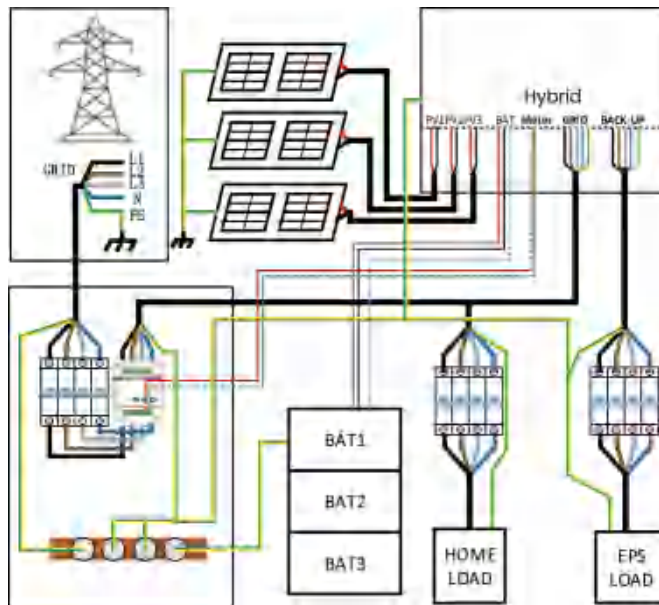

Work modes	Description
Self-use (with PV Power)	Priority: load>battery>grid The energy produced by the PV system is used to optimize self-consumption. The excess energy is used to charge the batteries, then exported to grid.
Self-use (without PV Power)	When no PV is supplied, the battery will discharge for local loads first. Battery will charge when excess generation from other generation sources is detected.
Feed in priority	Priority: load>grid>battery In the case of the external generator, the power generated will be used to supply the local loads firstly, then export to the public grid. The redundant power will charge the battery.
Back up mode	When the grid is off, system will supply emergency power from PV or battery to supply the home loads (Battery is necessary in EPS mode). Prioritize charging the battery, and ensure the battery does not discharge during grid-connected operation to maintain battery capacity for off-grid scenarios.
PeakShaving	The system can be set to provide a peak shaving function. A Peak Shaving limit must be set by adjusting "Import Limit" to the desired value. We can increase the peak shaving support uptime by setting the "Threshold SOC". When the battery is above the "Threshold SOC" the system will work in "Self-Use mode. When the battery is below the "Threshold SOC" the peak shaving function will be the priority and the system will only provide power from the battery when the "Import Limit" is exceeded. When below the "Threshold SOC" the system will charge from the grid when there is available power without exceeding the "Import Limit". This is to ensure prolonged Peak Shaving support for extended periods. If the "Import Limit" is exceeded constantly for an extended period of time, the peak shaving function can only guarantee successful operation while energy remains within the battery. If the battery designated "low level" is reached, the peak shaving function will cease.

★Charging time is when the battery is charged within the set time range. The setting of charging time can be used in the above work modes. The charging period is mainly used to set the charging time from the power grid to the battery. The PV can also charge the battery when there is sufficient PV outside of charging time.

Low-efficiency & Unbalanced-output: When the machine detects that the wiring of the electric meter and inverter is correct, it can output power based on the load size sampled by the electric meter. For example, the three circuits can output 1kW, 2kW, and 3kW respectively.

High-efficiency & Balanced-output only: Suitable for scenarios where balanced output is not a concern. The power output is evenly distributed across all three phases. For example, even if the loads are 1kW, 2kW, and 3kW, each phase will output 2kW uniformly.

Low-efficiency & Balanced-output only: The machine will default to this mode when it fails to detect correct wiring connections, preventing abnormal power output.

3.2 Dimensions

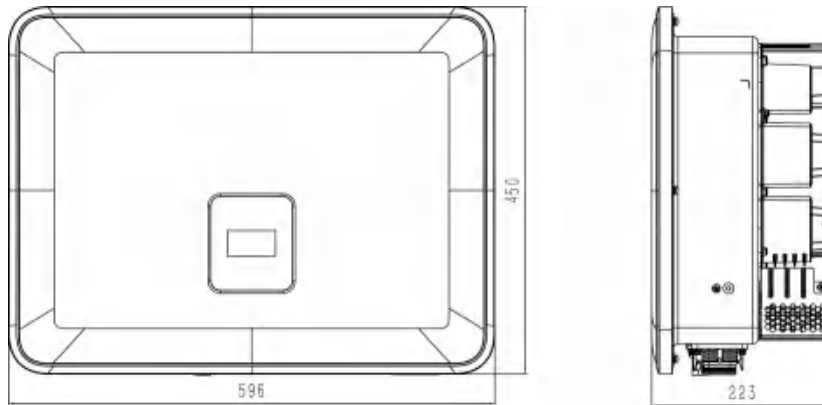

- This image is for reference only. The actual product received shall be final.

3.3 Terminals of inverter

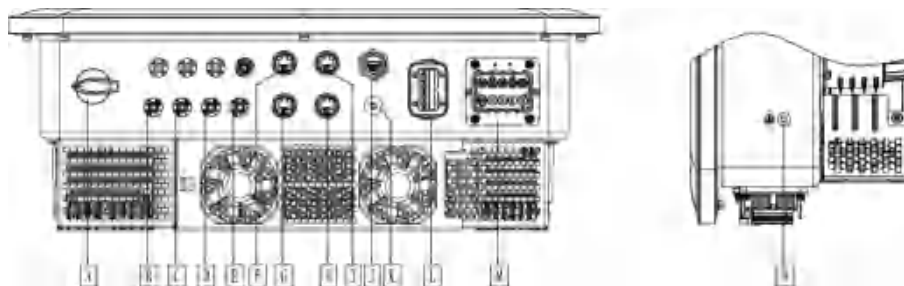

No.	Items	No.	Items
A	DC Switch	H	DRM
B	PV1	I	Meter
C	PV2	J	COMM/DONGLE
D	PV3 (For H3-Smart Only)	K	Antenna
E	BAT	L	COM
F	BMS	M	EPS/GRID
G	LAN	N	Grounding Screw

Note: Only authorized personnel are permitted to set the connection.

4 Technical Data

4.1 PV Input (For H3-Smart Only)

Model	H3-5.0-Smart	H3-6.0-Smart	H3-8.0-Smart	H3-9.9-Smart	H3-10.0-Smart	H3-12.0-Smart	H3-15.0-Smart
PV							
Max. DC Input Power [W]	11000	13200	17600	18000	18000	22500	22500
Max. DC voltage [V]	1000 ^[1]						
Nominal DC operating voltage [V]	620						
Max. MPPT Input Current [A]	20/20/20	20/20/20	20/20/20	20/20/20	20/20/20	20/20/20	20/20/20
Max. MPPT Short Circuit Current [A]	25/25/25	25/25/25	25/25/25	25/25/25	25/25/25	25/25/25	25/25/25
MPPT Voltage Range [V]	120-950	120-950	120-950	120-950	120-950	120-950	120-950
MPPT voltage range (full load) [V]	120-850	120-850	140-850	175-850	175-850	210-850	263-850
Start-up voltage [V]	140	140	140	140	140	140	140
No. of MPP trackers	3	3	3	3	3	3	3
Strings per MPP tracker	1+1+1	1+1+1	1+1+1	1+1+1	1+1+1	1+1+1	1+1+1

PV Input (For H3-M Only)

Model	H3-5.0-M	H3-6.0-M	H3-8.0-M	H3-10.0-M	H3-12.0-M	H3-15.0-M
PV						
Max. DC Input Power [W]	11000	13200	17600	18000	20000	20000
Max. DC voltage [V]	1000 ^[1]					
Nominal DC operating voltage [V]	620					
Max. MPPT Input Current [A]	20/20	20/20	20/20	20/20	20/20	20/20
Max. MPPT Short Circuit Current [A]	25/25	25/25	25/25	25/25	25/25	25/25
MPPT Voltage Range [V]	120-950	120-950	120-950	120-950	120-950	120-950
MPPT voltage range (full load) [V]	140-850	165-850	220-850	280-850	330-850	410-850
Start-up voltage [V]	140	140	140	140	140	140
No. of MPP trackers	2	2	2	2	2	2
Strings per MPP tracker	1+1	1+1	1+1	1+1	1+1	1+1

[1] For 1000V system, PV Maximum operating voltage is 950V.

4.2 Battery

Model	H3-5.0- Smart AC3-5.0- Smart H3-5.0-M	H3-6.0- Smart AC3-6.0- Smart H3-6.0-M	H3-8.0- Smart AC3-8.0- Smart H3-8.0-M	H3-9.9- Smart AC3-9.9- Smart	H3-10.0- Smart AC3-10.0- Smart H3-10.0-M	H3-12.0- Smart AC3-12.0- Smart H3-12.0-M	H3-15.0- Smart AC3-15.0- Smart H3-15.0-M
Battery Type	Lithium-Ion battery (LFP)						
Battery voltage [V]	100-800						
Full AC load Battery voltage [V]	108	125	160	210	210	250	310
Max. Charge/ discharge current [A]	50.0						
Communication interface	CAN						

4.3 AC Output/Input

Model	H3-5.0- Smart AC3-5.0- Smart H3-5.0-M	H3-6.0- Smart AC3-6.0- Smart H3-6.0-M	H3-8.0- Smart AC3-8.0- Smart H3-8.0-M	H3-9.9- Smart AC3-9.9- Smart	H3-10.0- Smart AC3-10.0- Smart H3-10.0-M	H3-12.0- Smart AC3-12.0- Smart H3-12.0-M	H3-15.0- Smart AC3-15.0- Smart H3-15.0-M
AC OUTPUT							
Nominal AC power [VA]	5000	6000	8000	9900	10000	12000	15000
Max. apparent AC power [VA]	5500	6600	8800	9900	11000	13200	16500
Rated Grid Voltage (AC voltage range) [V]	400V/230Vac; 380V/220Vac, 3L/N/PE						
Rated grid frequency [Hz]	50/60Hz, ±5Hz						
Max. AC Current (Per phase) [A]	8.3	10.0	13.3	15.0	16.7	20.0	25.0
Power Factor	1 (Adjustable from 0.8 leading to 0.8 lagging)						
Export Control	YES						
AC inrush current [A]	15A@0.5ms						
Max. output fault current [A]	150A@0.5ms						
Max. output over current protection [A]	50						
THDI	<3%@rated power						
AC INPUT							
Max. AC power [VA]	6000	7200	9600	12000	12000	14400	16000
Rated grid voltage (AC voltage range) [V]	400V/230Vac; 380V/220Vac, 3L/N/PE						
Rated grid frequency [Hz]	50/60Hz, ±5Hz						
Max. AC current [A] (Per phase)	9.1	10.9	14.5	18.2	18.2	21.8	24.2
AC inrush current [A]	15A@0.5ms						

4.4 EPS Output

Model	H3-5.0-Smart AC3-5.0-Smart H3-5.0-M	H3-6.0-Smart AC3-6.0-Smart H3-6.0-M	H3-8.0-Smart AC3-8.0-Smart H3-8.0-M	H3-9.9-Smart AC3-9.9-Smart	H3-10.0-Smart AC3-10.0-Smart H3-10.0-M	H3-12.0-Smart AC3-12.0-Smart H3-12.0-M	H3-15.0-Smart AC3-15.0-Smart H3-15.0-M
EPS OUTPUT (WITH BATTERY)							
Max. Apparent AC Power [VA]	5000	6000	8000	10000	10000	12000	15000
Peak Apparent AC Power [VA] (60s)	6000	7200	9600	12000	12000	14400	15000
Rated output voltage [V]	400V/230VAC; 3L/N/PE						
Rated grid Frequency [Hz]	50/60	50/60	50/60	50/60	50/60	50/60	50/60
EPS Max Current (Per phase) [A]	7.2	8.7	11.6	14.5	14.5	17.4	21.7
Power Factor	1 (Adjustable from 0.8 leading to 0.8 lagging)						
Parallel operation	Yes@max10Pcs						
Switch time	<20ms						
THDV	<3%@Linear Load						

4.5 Efficiency and Protection

Model	H3-5.0-Smart AC3-5.0-Smart H3-5.0-M	H3-6.0-Smart AC3-6.0-Smart H3-6.0-M	H3-8.0-Smart AC3-8.0-Smart H3-8.0-M	H3-9.9-Smart AC3-9.9-Smart	H3-10.0-Smart AC3-10.0-Smart H3-10.0-M	H3-12.0-Smart AC3-12.0-Smart H3-12.0-M	H3-15.0-Smart AC3-15.0-Smart H3-15.0-M
EFFICIENCY							
MPPT Efficiency	99.90%	99.90%	99.90%	99.90%	99.90%	99.90%	99.90%
Max. Efficiency	97.30%	97.70%	97.70%	97.90%	97.90%	97.90%	97.90%
Euro-Efficiency	97.20%	97.20%	97.20%	97.20%	97.20%	97.20%	97.20%
PROTECTION							
PV Reverse Polarity Protection	YES						
Battery Reverse Protection	YES						
Anti-islanding protection	YES						
Output short protection	YES						
Leakage Current Protection	YES						
Insulation Resistor Detection	YES						
Over Voltage category	III (AC side), II (DC side)						
Reverse connect protection	YES						
Over-current protection /Over-temperature protection	YES						
DC/AC Surge Protection	Type II (PV)/Type II (AC)						
AFCI protection	optional						
DC switch	YES						

4.6 General Data

DIMENSION AND WEIGHT		
Dimensions (W*H*D) [mm]	600*450*226	
Net Weight (5-10KW) [kg]	33.5	
Cooling	Natural	FAN cooling
Inverter topology	Non-isolated	
Communication interface	Ethernet, EMS(RS 485), Meter, WiLAN(WiFi+LAN+Bluetooth), 4G(Optional), DRM, Ripple Control, USB, BMS(CAN), SG Ready	
LCD display	Backlight 16*4 character	
ENVIRONMENT LIMIT		
Installation	wall-mounted	
Ingress protection	IP65 (For Outdoor Use)	
Operating Temperature Range [°C]	-25 to +60°C (Derating at 45°C)	
Storage/Operation relative humidity	0%-100%	
Altitude [m]	<4000@Derating exceeding 2000m	
Protective class	I	
Storage Temperature	-40 to+70°C	
Standby consumption [W]	20W	
Idle mode	YES	
Button	Capacitive Touch Sensor * 4	
Buzzer	1, Inside (EPS&Earth fault)	

5 Installation

5.1 Installation Precautions

Danger!

- Do not wear loose clothing or jewelry when performing installation work, otherwise there may be a risk of electric shock!
- Before carrying out installation work, make sure that the mechanical strength of the installation location is sufficient to support the weight of the equipment, otherwise a mechanical hazard may result.

Warning!

All jumper components and component-mounted racks must be properly grounded, with unpainted contact surfaces.

Please strictly observe the following safety tips during installation operations. Otherwise, personal injury or death may occur.

- Installation must be performed properly by a professional under conditions that follow all warning tips.
- Nickel-plated copper is recommended, but aluminum can also be used.
- Remove the oxide layer and apply a suitable antioxidant caulking mix before connecting the aluminum busbar.
- For ease of installation and maintenance, it is recommended that sufficient space be allowed around the equipment: adequate cooling airflow, required clearances, and space needed for cables and cable support structures.

5.2 Unpackaging

Note!

Please open the package in order and do not knock it violently!

The following items must be checked before and after opening the box:











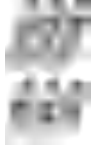

No.	Items
1	Check the appearance for any damage, scratches, dents, etc.
2	Check if all the accessories are included.
3	Check if the nameplate information matches the model of the ordered product.
4	Check the warning label for any damage, scratches, fading, etc.

Unpacking Precautions

- During storage, the packaging must not be removed. It should only be removed when the equipment is ready for installation.
- Before unboxing, inspect the product's external packaging for any issues such as damage, breakage, moisture, dampness, or deformation.
- During unboxing, check the product and its accessories for surface defects like damage, rust, or dents.

Packing List

When receiving the goods from the carrier, it is essential to conduct a thorough and careful inspection of the products. Check each received item against the delivery slip. If any items are missing or damaged, the carrier should be notified immediately upon discovery. The packing list is as shown below:

 <p>Inverter*1</p>	 <p>Bracket*1</p>	 <p>PV connectors (Only for Hybrid) (positive*3, negative*3)</p>	 <p>PV pin contacts (Only for Hybrid) (positive*3, negative*3)</p>
 <p>AC connector*1</p>	 <p>Expansion tubes*6 & Expansion screws*6</p>	 <p>Earth terminal*1</p>	 <p>Communication connector*1</p>
 <p>Quick installation guide*1</p>	 <p>3ph Meter <80A*1</p>	 <p>Hexagonal screws*3</p>	 <p>Battery connectors (positive*1, negative*1)</p>

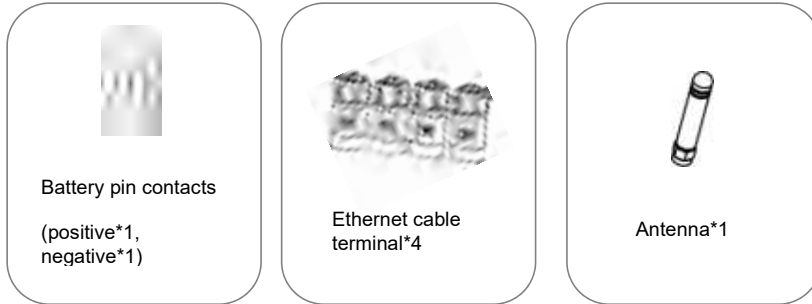

5.3 Installation Requirements

Selecting the optimal installation location for the inverter plays a very important role in its safe operation, life assurance and performance guarantee.

Environment Requirements

Warning!

The inverter generates high temperature during operation, so please install it in a location where it cannot be touched by human beings or isolate it by installing a protective net and erecting a safety warning sign on the outside.

Note!

Site selection should be in accordance with local laws and regulations and relevant standard requirements.

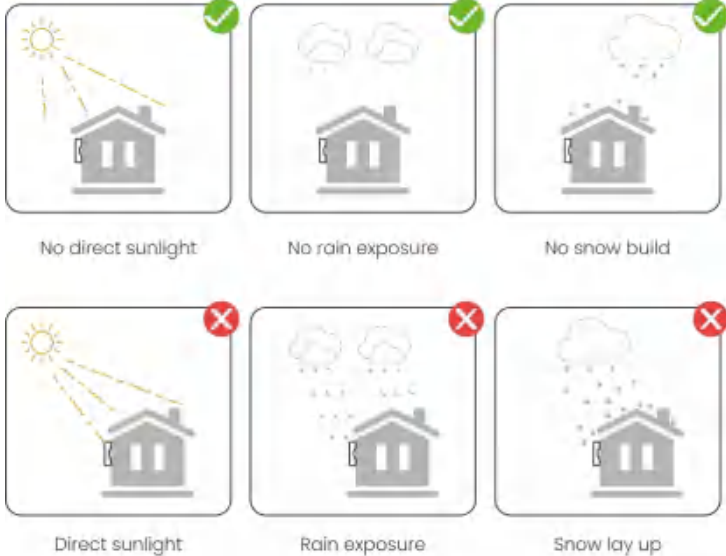
Items	Requirements
Location	<ul style="list-style-type: none"> ● Not in direct sunlight. ● Not in areas where highly flammable materials are stored. ● Not in potential explosive areas. ● Not in the cool air directly. ● Not near the television antenna or antenna cable. ● Not higher than altitude of about 2000m above sea level. ● Not in environment of precipitation or humidity (>95%). ● Under good ventilation condition. ● The ambient temperature in the range of -25°C to +60°C. ● The slope of the wall should be within +5°. ● The wall hanging the inverter should meet conditions below: ● Solid brick/concrete, or strength equivalent mounting surface; ● Inverter must be supported or strengthened if the wall's strength isn't enough (such as wooden wall, the wall covered by thick layer of decoration). ● Please avoid direct sunlight, rain exposure, snow laying up during installation and operation. <div style="text-align: center; margin-top: 20px;">  <p>The diagram consists of six square icons arranged in two rows of three. The top row shows correct conditions: 1. 'No direct sunlight' with a green checkmark, showing a house with a sun icon and rays that do not hit the house. 2. 'No rain exposure' with a green checkmark, showing a house with rain clouds above it but no rain falling on it. 3. 'No snow build' with a green checkmark, showing a house with snow falling from a cloud but not accumulating on the roof. The bottom row shows incorrect conditions: 1. 'Direct sunlight' with a red 'X', showing a house with sun rays hitting it. 2. 'Rain exposure' with a red 'X', showing a house with rain falling on it. 3. 'Snow lay up' with a red 'X', showing a house with snow accumulating on its roof.</p> </div>

⚠ Warning!

The intrusion of moisture can easily cause damage to the equipment! For normal use of the equipment:

- Do not open the cabinet door when the air humidity exceeds 95%.
- Avoid opening the cabinet door, performing maintenance or overhauling, etc., in rainy, lightning or humid weather conditions.

Installation Surface Requirements

Warning!

Mounting the inverter on a wall that does not meet the specified conditions may cause equipment damage. Any resulting damage will not be covered under the warranty.

Requirements for the Wall

The wall used for mounting the inverter must meet the following conditions:

- It must be a solid brick/concrete surface or a surface of equivalent strength, and must be capable of bearing the weight.
- If the wall lacks sufficient strength (e.g., column walls or walls with thick decorative coverings), the inverter must be properly supported or reinforced.
- It is strictly prohibited to install the inverter on flammable surfaces or surfaces prone to resonance.
- It should be installed on a wall with good sound insulation to reduce the impact of operational noise.

Requirements for Foundation

The foundation for the inverter must meet the following conditions:

- The installation surface must be flat, dry, and must be free of standing water.
- Ensure the ground is level, stable (without shaking), and can support the equipment's weight.
- If installed in an area with abundant vegetation, in addition to routine weeding, the ground beneath the equipment must be hardened (e.g., by laying concrete, gravel, etc.) over an area of no less than 3m × 2.5m.

Requirements for Space

Adequate space must be reserved around the inverter, and a suitable installation angle must be selected to ensure sufficient room for installation and heat dissipation. The specific space requirements for a single inverter are illustrated in the following diagram.

Warning!

The intrusion of moisture can easily cause damage to the equipment! For normal use of the equipment:

- Do not open the cabinet door when the air humidity exceeds 95%.
- Avoid opening the cabinet door, performing maintenance or overhauling, etc., in rainy, lightning or humid weather conditions.

Installation Surface Requirements

⚠ Warning!

Mounting the inverter on a wall that does not meet the specified conditions may cause equipment damage. Any resulting damage will not be covered under the warranty.

Requirements for the Wall

The wall used for mounting the inverter must meet the following conditions:

- It must be a solid brick/concrete surface or a surface of equivalent strength, and must be capable of bearing the weight.
- If the wall lacks sufficient strength (e.g., column walls or walls with thick decorative coverings), the inverter must be properly supported or reinforced.
- It is strictly prohibited to install the inverter on flammable surfaces or surfaces prone to resonance.
- It should be installed on a wall with good sound insulation to reduce the impact of operational noise.

Requirements for Foundation

The foundation for the inverter must meet the following conditions:

- The installation surface must be flat, dry, and must be free of standing water.
- Ensure the ground is level, stable (without shaking), and can support the equipment's weight.
- If installed in an area with abundant vegetation, in addition to routine weeding, the ground beneath the equipment must be hardened (e.g., by laying concrete, gravel, etc.) over an area of no less than 3m × 2.5m.

Requirements for Space

Adequate space must be reserved around the inverter, and a suitable installation angle must be selected to ensure sufficient room for installation and heat dissipation. The specific space requirements for a single inverter are illustrated in the following diagram.

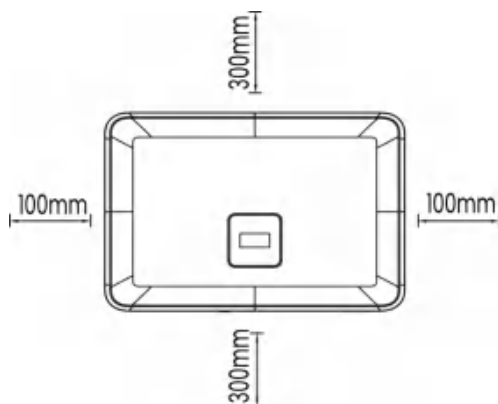

Position	Min. space (mm)
Left	100
Right	100
Top	300
Bottom	300

5.4 Tools Preparation

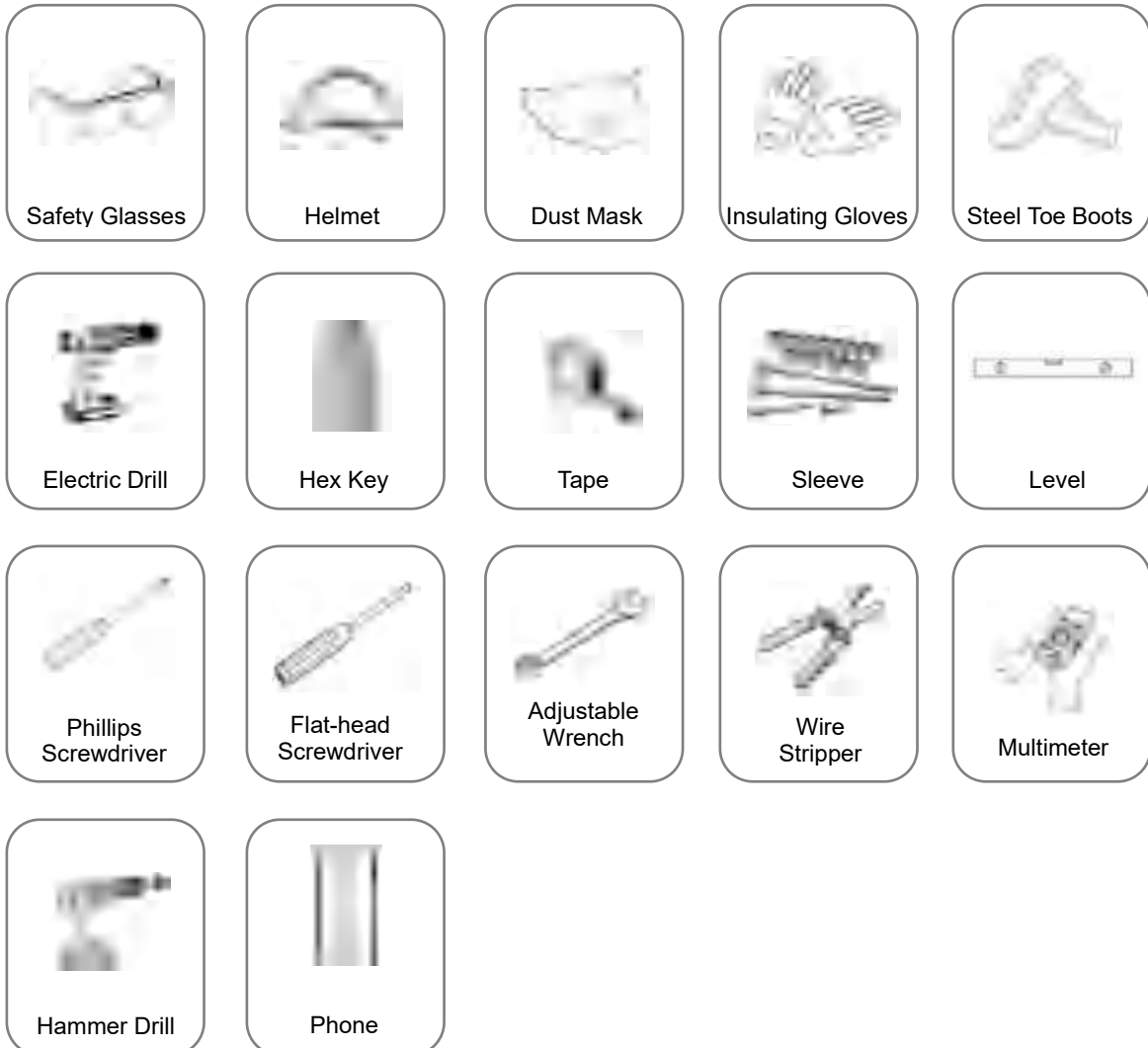

5.5 Inverter Handling

- When manually handling the unit, wear protective gloves, safety shoes, and other personal protective equipment to prevent injury during the process.
- Use correct lifting posture: Bend your knees to lower your center of gravity, grasp the inverter handles with both hands, and slowly straighten your knees, using the strength of your legs to lift the load. Keep the load close to your body and move using short, quick steps.
- Always maintain body balance during handling. Avoid making sudden turns or changes in direction.
- If a turn is necessary, execute it slowly and adjust your body posture in advance.
- If you feel fatigued or lack sufficient strength, you must stop handling immediately.

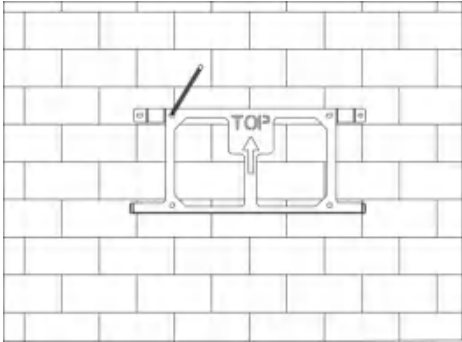
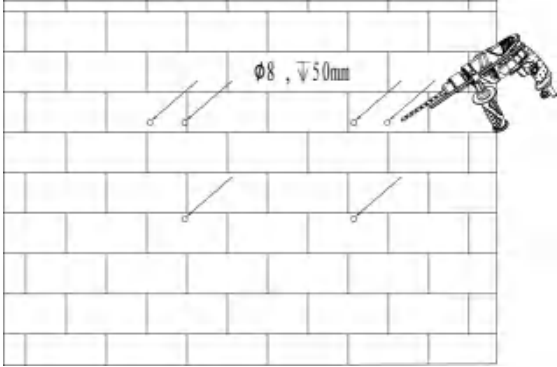
<p>Step 2</p>	<p>Before drilling holes, please ensure the distance between the machine and nearby objects.</p> 
<p>Step 3</p>	<p>Drill holes with electric drill, make sure the holes are at least 50mm deep and 8mm wide, and then tighten the expansion tubes.</p> <p style="text-align: center;">⚠ Warning!</p> <p>Please pay attention to safety when using the tools. Unsafe use of the drilling tools may cause damage to the body.</p> <p>Please select solid brick-concrete structure and concrete wall for installation location. If other types of wall are selected, the wall must be made of fire-retardant materials and meet the load bearing requirements of the equipment.</p> 
<p>Step 4</p>	<p>Insert the expansion tubes into the holes and tighten them. Install the bracket with the expansion screws.</p>

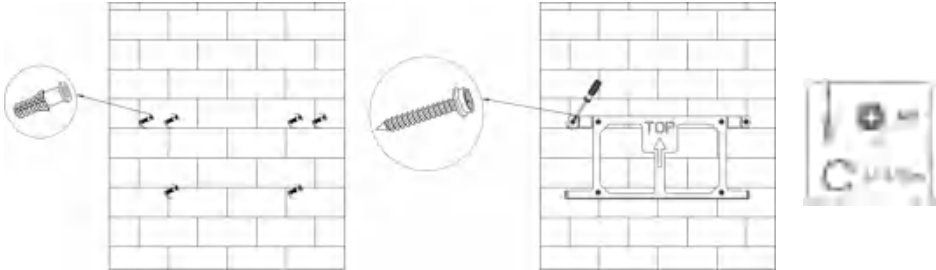
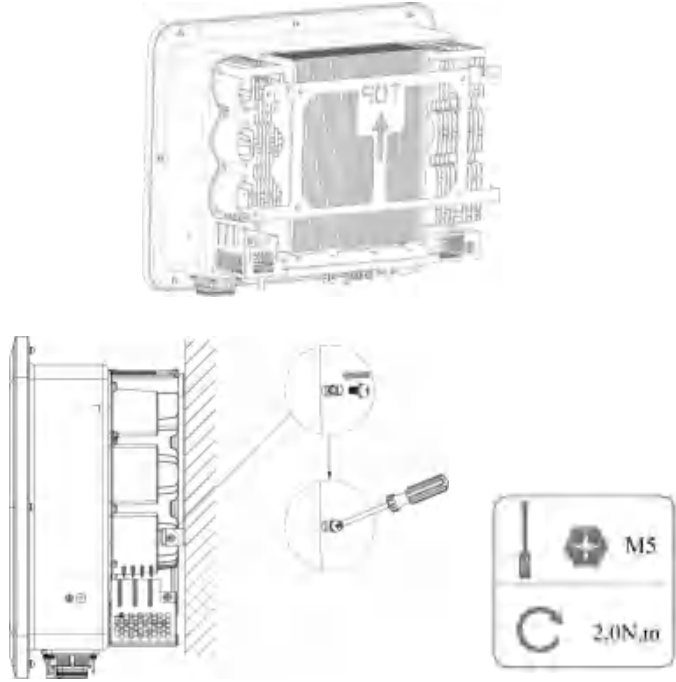
	
<p>Step 5</p>	<p>Match the inverter with wall bracket</p> <p>Mount the inverter to the bracket. Secure the inverter with the M5 screw and washer.</p> 

Warning!

Operators should wear protective goggles and dust masks to prevent dust from being inhaled into the lungs or falling into the eyes when punching.

Note!

The upper face of the expansion tubes must be made sure that it is level with the concrete wall surface and does not protrude from the concrete wall surface, otherwise it will make the wall plate unevenly placed on the wall surface.

6 Electrical Connection

6.1 Circuit Overview

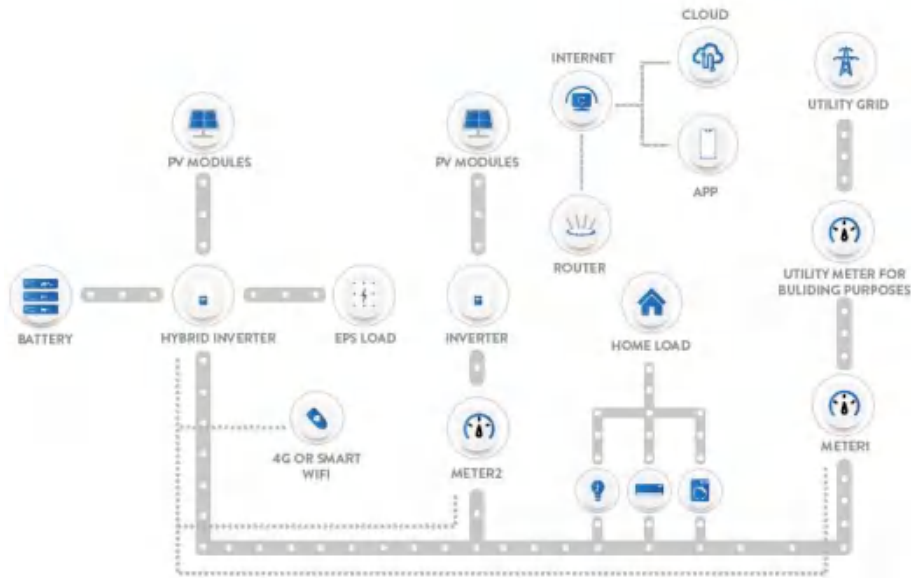

system overview

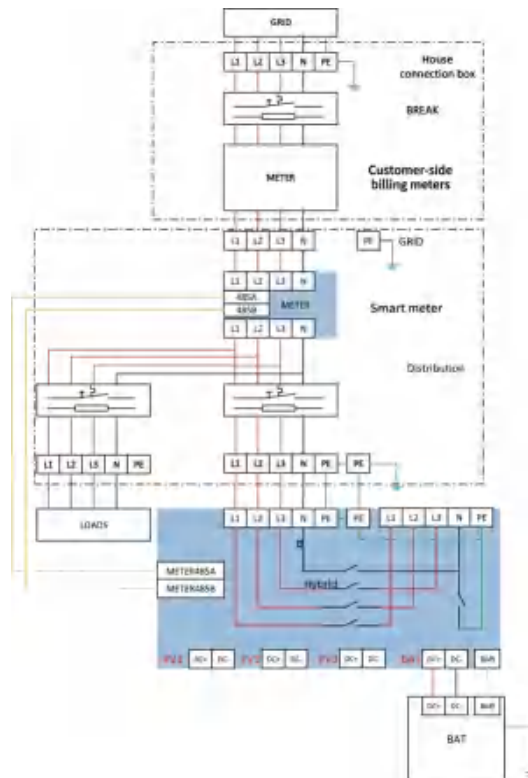

6.2 PV Connection (For H3-M/H3-Smart Only)

Step 1: PV String Connection

Note!

Please choose a suitable external DC switch if the inverter does not have a built-in DC switch.

Warning!

PV module voltage is very high and within a dangerous voltage range, please comply with the electric safety rules when connecting.

Warning!

Please do not make PV positive or negative to ground!

Note!

PV modules: Please ensure they are the same type, have the same output and specifications, are aligned identically, and are tilted to the same angle. In order to save cable and reduce DC loss, we recommend installing the inverter as near to the PV modules as possible.

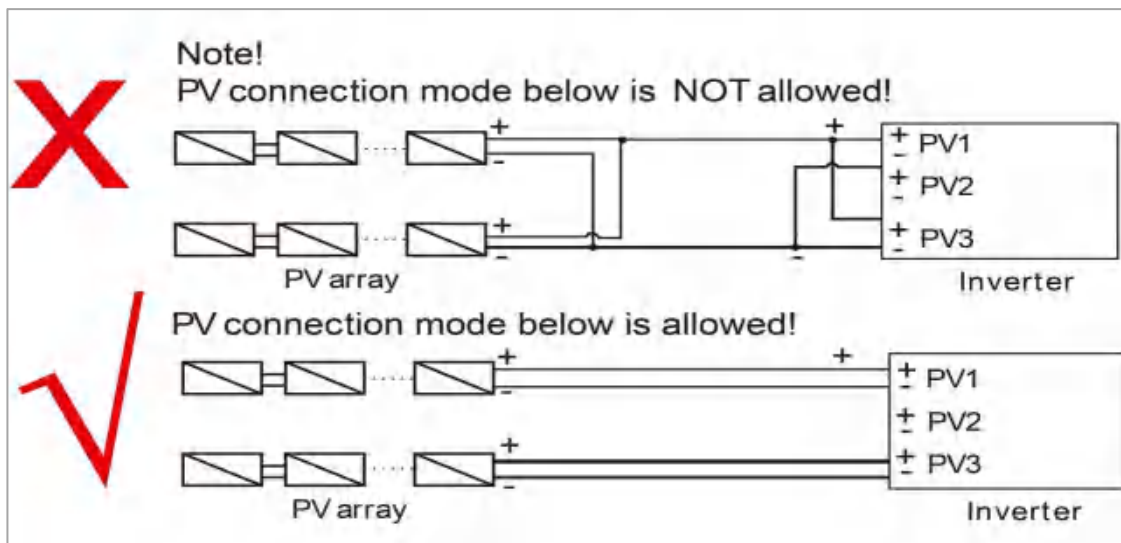

Step 2: PV Wiring

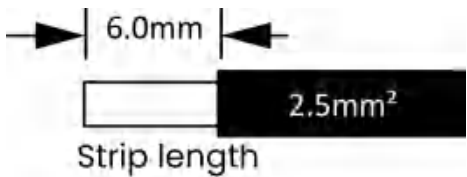
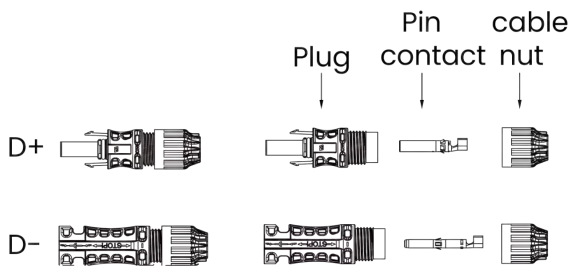
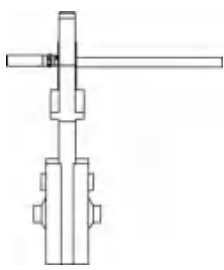
Procedures	
Step 1	<p>Turn off the DC switch. Choose 2.5mm² wire to connect the PV module. Trim 6mm of insulation from the wire end.</p> 
Step 2	<p>Separate the PV connector as below.</p>  <p style="text-align: center;">Note!</p> <p>When making PV terminals, please make sure that the copper cores of PV positive and PV negative terminals and the copper cores on the inverter can be inserted, and use a multimeter to measure whether the positive and negative terminals are correct, otherwise the machine may not work normally or individual strings may not work.</p>
Step 3	<p>The maximum open-circuit voltage of PV should be less than 900V, otherwise an error may be reported when mppt cannot be traced.</p> <p>Insert striped cable into pin contact and ensure all conductor strands are captured in the pin contact.</p> <p>Crimp pin contact by using a crimping plier. Put the pin contact with striped cable into the corresponding crimping pliers and crimp the contact.</p> 

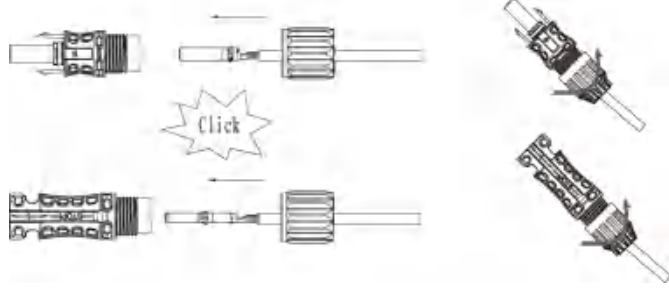
Step 4	<p>Insert pin contact through the cable nut to assemble into back of the male or female plug. When you feel or hear a "click" the pin contact assembly is seated correctly.</p>
	

Unlock the DC connector

⚠ Danger!

Before separating the DC connector, make sure that there is no current on the DC connector. You can measure it with current clamp or disconnect the DC switch, otherwise serious safety accidents may occur.

Make sure that the power cable connected to the inverter is connected vertically and that the vertical length is greater than 30 cm. If the cable is bent close to the terminals, it may cause poor line contact and result in burnt terminals.

- Use the specified wrench tool.
- When separating the DC + connector, push the tool down from the top.
- When separating the DC - connector, push the tool down from the bottom.
- Separate the connectors by hand.

6.3 Battery Connection

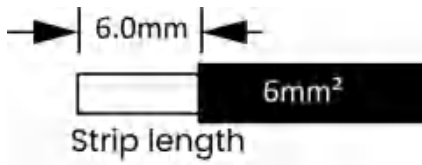
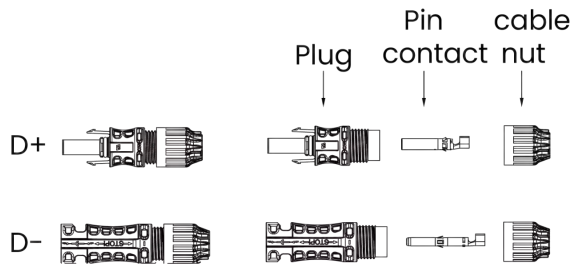
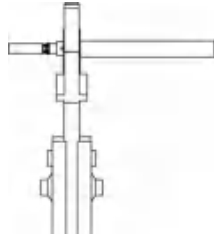
Procedures	
Step 1	<p>Turn off the DC switch. Choose 6mm² wire to connect the battery. Trim 6mm of insulation from the wire end.</p> 
Step 2	<p>Separate the DC connector (battery) as below.</p>  <p style="text-align: center;">Note!</p> <p>We offer matching battery power harnesses and communication harnesses. Please use matching harness. The matched battery power harness and communication harness are in the battery packaging box.</p>
Step 3	<p>Insert striped cable into pin contact and ensure all conductor strands are captured in the pin contact. Crimp pin contact by using a crimping plier. Put the pin contact with striped cable into the corresponding crimping pliers and crimp the contact.</p> 
Step 4	<p>Insert pin contact through the cable nut to assemble into back of the male or female plug. When you feel or hear a "click" the pin contact assembly is seated correctly.</p>

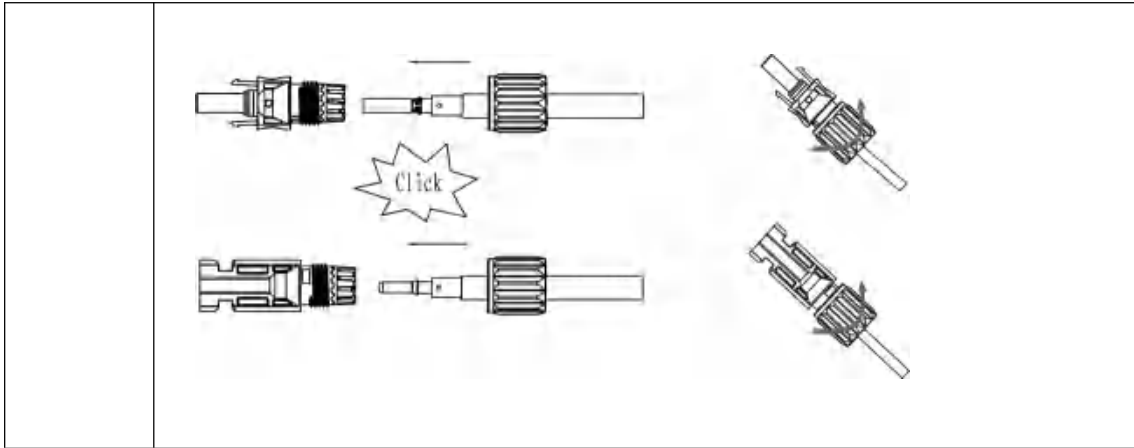

- Unlock the DC connector

⚠ Danger!

Before disconnecting the DC connector, make sure that there is no current on the DC connector. You can use the current clamp to measure or disconnect the battery switch, otherwise serious safety accidents may occur. At the same time, the harness on the battery cannot be reversed or shorted, which will cause irreparable damage to the battery or inverter.

- Use the specified wrench tool.
- When separating the DC + connector, push the tool down from the top.
- When separating the DC - connector, push the tool down from the bottom.
- Separate the connectors by hand.

6.4 Grid Connection

Step 1: Grid String Connection

Hybrid series inverters are designed for three-phase grid. Per voltage range is 220/230/240V; frequency is 50/60Hz. Other technical requests should comply with the requirement of the local public grid.

Model (kW)	5.0	6.0	8.0	10.0	12.0	15.0
Cable (ON-GRID)	4.0mm ²			6.0mm ²		6.0mm ²
Cable (EPS)	4.0mm ²			6.0mm ²		6.0mm ²
Micro-Breaker	20A			25A		32A

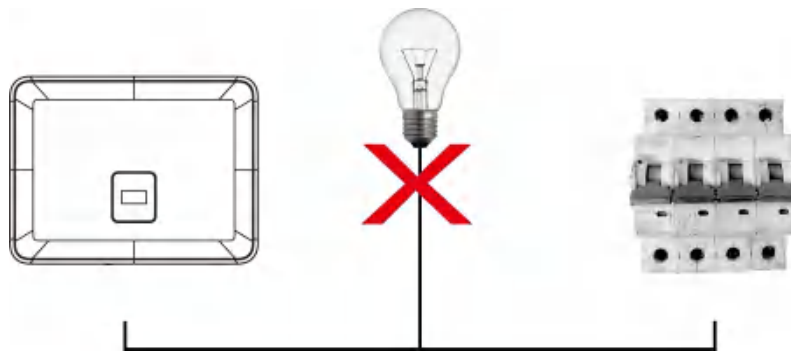

⚠ Warning!

A micro-breaker for max output overcurrent protection device shall be installed between inverter and grid, and the current of the protection device is referred to the table above, any load SHOULD NOT be connected with the inverter directly.

Step 2: Grid Wiring

- Check the grid voltage and compare with the permitted voltage range (refer to technical data).
- Disconnect the circuit-breaker from all the phases and secure against re-connection.
- Trim the wires:
 - Trim all the wires to 52.5mm and the PE wire to 55mm.
 - Use the crimping pliers to trim 12mm of insulation from all wire ends as below.

A. GRID Wiring

Note!

The wiring of the power grid must be connected to the N line, otherwise the machine will report an error and cannot work normally. The SW BUS Volt fault will appear. The method to detect whether the N line is connected is to measure whether the voltage of each phase is within the normal working voltage range separately. Then disconnect one of the live wires and check whether the voltage of the other two phases is within the range. If it is within the range, it means that the N wire is connected. If, after disconnecting the live wire, the voltage of the other two phases changes, it means that the N wire is not connected.

6.5 Earth Connection

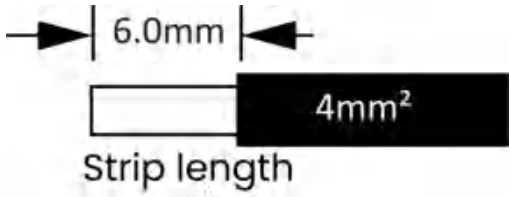
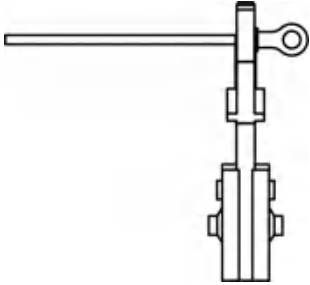
Procedures	
Step 1	<p>Trim 6mm of insulation from the wire end.</p> 
Step 2	<p>Insert striped cable into earth terminal and ensure all conductor strands are captured in the earth terminal.</p> <p>Crimp earth terminal by using a crimping pliers. Put the earth terminal with striped cable into the corresponding crimping pliers and crimp the contact.</p> 
Step 3	<p>Use the crimping pliers to press the ground cable into the ground terminal, screw the ground screw with screwdriver as shown below.</p>

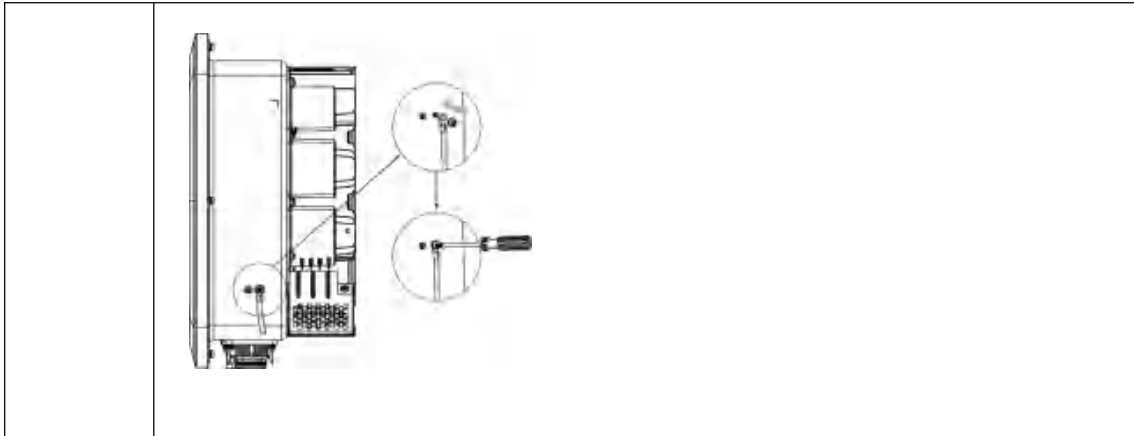

6.6 Installation Instructions

Procedures	
Step 1	<p>1) Dimension of stripping line. Dimension of stripping line outside machine.</p> <p>5-core copper wire</p> <p>4-core copper wire+ Single-core copper wire</p>
Step 2	<p>2) Wiring Precautions.</p> <p>Clockwise sequence</p> <p>Counterclockwise sequence</p>
Step 3	<p>3) Seal accessory option.</p> <p>A. Ø18: The recommended outer diameter of the cable is 17.5-18.5mm.</p> <p>B. Ø21: The recommended outer diameter of the cable is 19-21mm.</p> <p>C. Ø6: When the four wire system is used, the special hole for the ground wire is recommended to be applicable to the outer diameter of the cable. (5~6mm)</p>

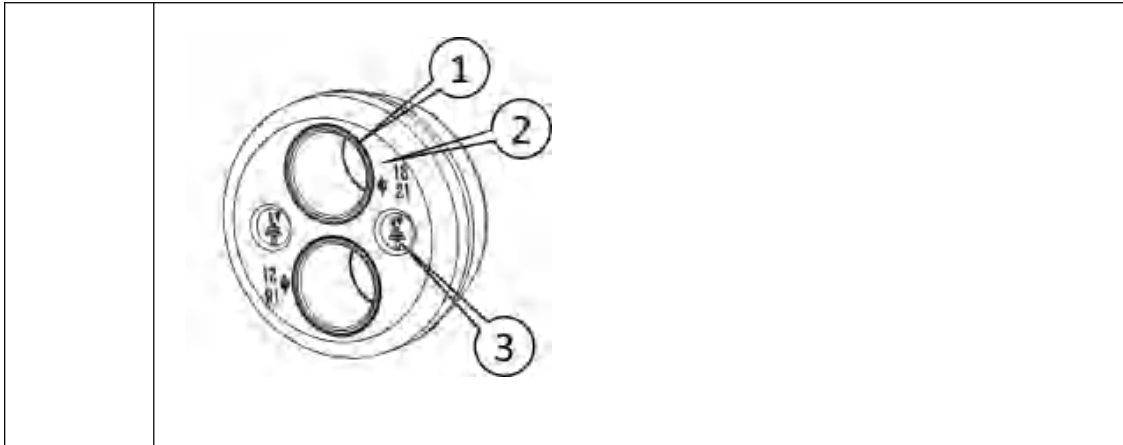

★If the outer diameter of the cable is greater than 18mm, remove part 1. When 4-core wire is used, Ø6 holes are ground wire through holes. Remove part 3.

6.7 Installation steps for 5-core wire

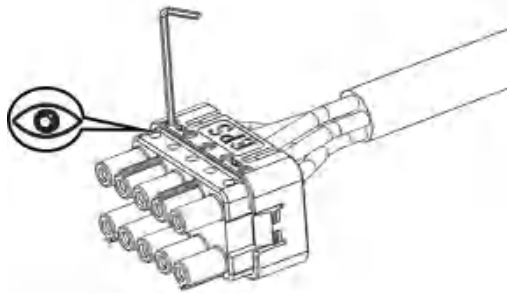
Procedures	
Step 1	<p>Thread the stripped wire into the lock nut and the main body in turn. (the flexible wire needs to be riveted to the insulated terminal)</p> 
Step 2	<p>First, insert the EPS end cable into the EPS end of the rubber core. After the cable is in place through the perspective hole, tighten the screw using an S2.5 hexagon wrench with a torque of $2.5 \pm 0.1 \text{ N} \cdot \text{m}$.</p> 
Step 3	<p>Insert the GRID end-core wire into the GRID end of the rubber core, observe the perspective hole cable in place, use S2.5 hex wrench to tighten the screws, torque</p>

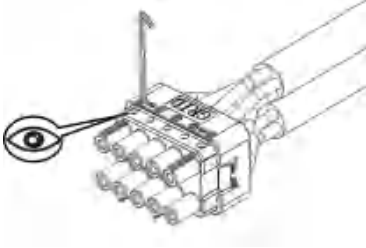
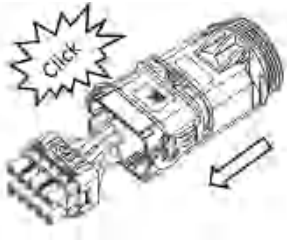
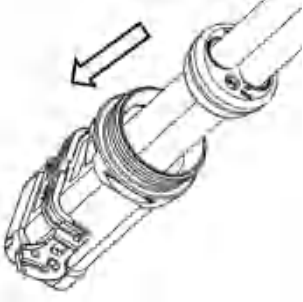
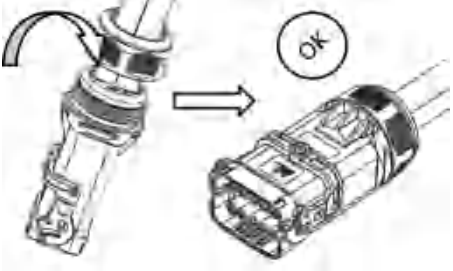
	<p>2.5±0.1N·m;</p> 
<p>Step 4</p>	<p>Insert the main body into the rubber core and hear the "click" sound.</p> 
<p>Step 5</p>	<p>Seal plugin to main body.</p> 
<p>Step 6</p>	<p>Tighten the nut with an open-ended wrench. (torque 10.0±0.1N·m, Complete the installation)</p> 

Inserted

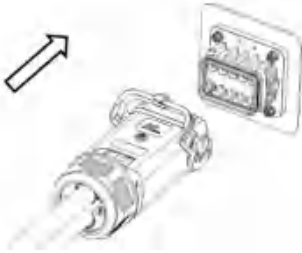
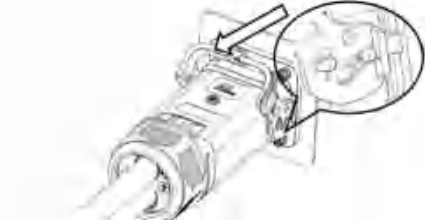
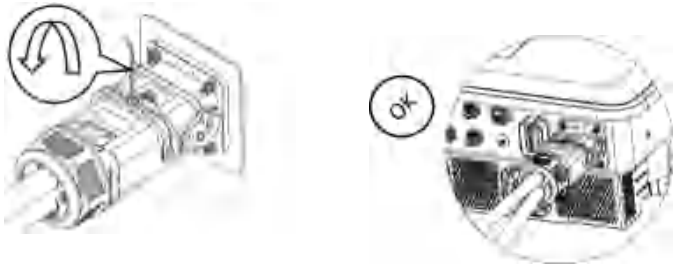
Procedures	
Step 1	<p>Open the latch.</p> 
Step 2	<p>Align the female end with the male end in the anti-stay position.</p> 
Step 3	<p>After the male and female insert the card point into the tracks lot, press the lock.</p> 
Step 4	<p>Tighten the screws with the S2.5 hexagon wrench with a torque of $2.5 \pm 0.1 \text{ Nm}$. Installation completed.</p> 

6.8 RJ45 connection

The machine has three RJ45 terminals, which are meter, Ethernet, and RCR functions

The definition of meter port pin is as follows:

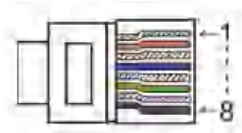

Port \ PIN	1	2	3	4	5	6	7	8
Meter	meter 485B	meter 485A	/	/	/	/	meter 485B	meter 485A

The definition of Ethernet port pin is as follows:

Port \ PIN	1	2	3	4	5	6	7	8
Ethernet	TX+	TX-	RX+	/	/	/	RX-	/

The definition of DRM port pin is as follows:

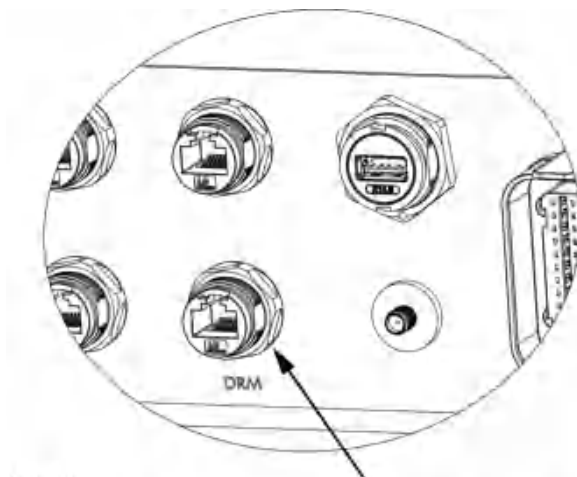

Port \ PIN	1	2	3	4	5	6	7	8
Ethernet	+3.3V	DRM1	DRM2	DRM3	DRM4	DRM0	GND	GND



Note:
Red rubber ring - new version DRM interface;
white rubber ring - old version DRM interface.

RJ45 Wiring

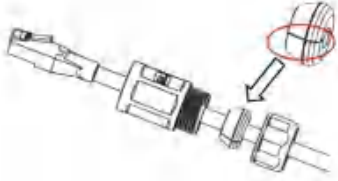
Installation Procedure

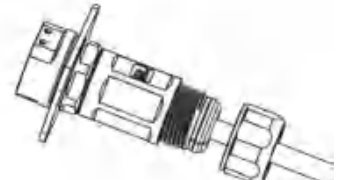
Procedures	
Step 1	<p>Insert the network cable into the wire-locking nut, sealing plug and mainbody in turn. The sealing plug is stuck into the network cable through the gap on the sealing side.</p>
	<div style="display: flex; align-items: center;">  <div style="margin-left: 20px;"> <p>Stuck into the network cable through the gap on the sealing side.</p> </div> </div>
Step 2	<p>Insert the network cable plug into the matched RJ45 panel mount connector.</p>
	
Step 3	<p>Tighten the connector mainbody by the open-ended wrench into the RJ45 panel mount connector with a torque $1.2 \pm 0.2 \text{N}\cdot\text{m}$.</p>
	
Step 4	<p>Insert the sealing plug into the main body of RJ45 cable end connector.</p>
	

Step 5	Tighten the connector's nut by the open-ended wrench with a torque $1.2\pm 0.2\text{N}\cdot\text{m}$.
	

6.9 Antenna Connection

Tighten the Antenna's nut by the open-ended wrench with a torque $1.2\pm 0.3\text{N}\cdot\text{m}$.

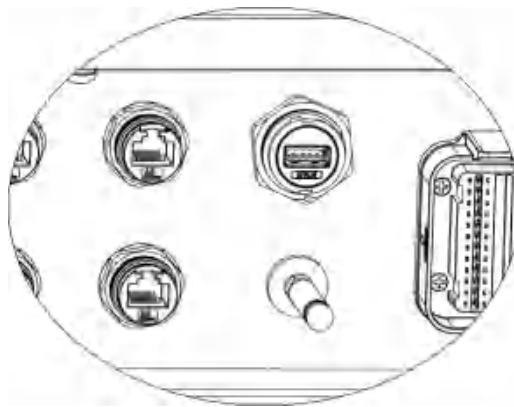

6.10 COM connection

Introduction to COM port:

The COM port mainly includes EMS485, Meter485, WIFI485, Estop port, two relay output ports, two parallel ports and a toggle switch, +12V and corresponding relay output signals.

The ripple control function is described below.

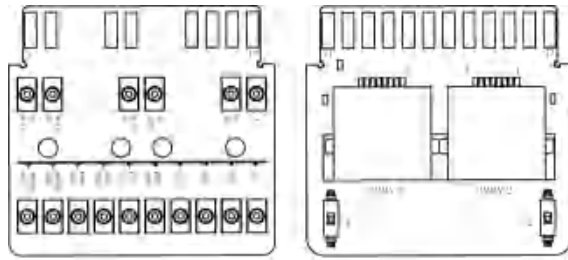

EMS 485:

Supports Modbus485 communication, which can be used to read and control machines.

The specific protocol is provided by the manufacturer.

Meter 485:

Similar to the Meter485 interface, this interface is designed to be redundant.

Wifi 485:

For internal testing.

Estop port:

When short circuiting ESTOP and GND, the machine will stop working.

DY OUT:

The machine has two DY OUT interfaces, with two internal contacts of relays that can drive loads of 230VAC1A/50VDC0. 5A, and can be used for powering on and starting heat pumps.

PARA port RJ45:

Used for parallel communication, it is necessary to set the DIP switch to the ON state during parallel operation. +12V and RY-Out are used to control external relay switches and cannot be used for other functions.

24PIN Wiring**Installation Procedure**

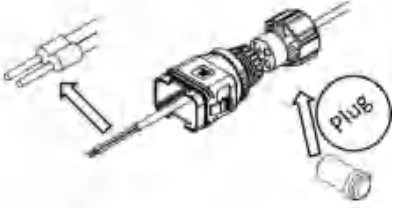
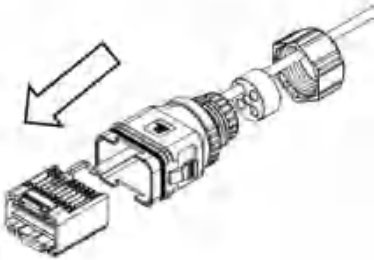
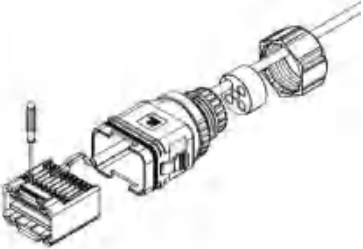
Procedures	
Step 1	<p>Remove the plug inside the plug and thread the terminal according to the sequence shown in the illustration.</p> 
Step 2	<p>Insert the wires into the corresponding terminals.</p> 
Step 3	<p>And use a screwdriver to crimp the wire, screwing torque 1.2+/-0.1N·m.</p> 
Step 4	<p>Arrange the core line, the rubber core area must not appear to ride the line. The rubber core is loaded into the main body and accompanied by a "click" sound.</p>

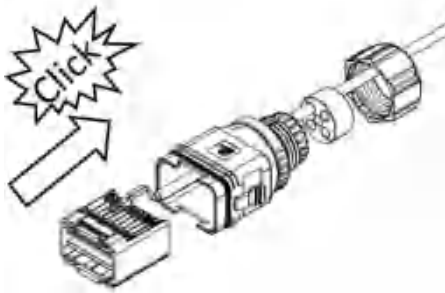
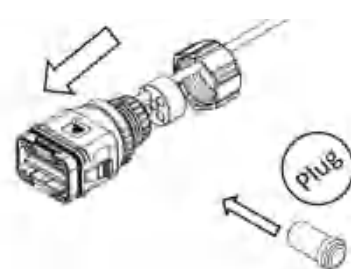
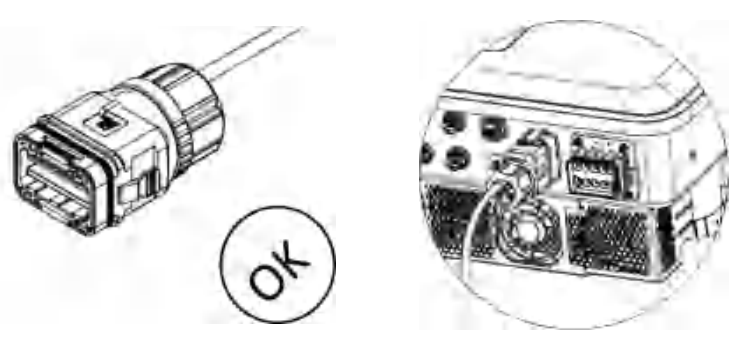
	
<p>Step 5</p>	<p>Install the plug into the main body and plug the holes without wires with a plug.</p>
	
<p>Step 6</p>	<p>Lock wire nut screwed onto the body, torque 2.5+/-0.1N-m, then complete installation.</p>
	

6.11 Electrical Connection

A. Communication Device Installation (Optional)

Hybrid series inverters are available with multiple communication options such as WiFi-, GPRS-, LAN- or 4G-Dongle, RS485 and Smart meter with an external device.

Operating information like output voltage, current, frequency, fault information, etc., can be monitored locally or remotely via these interfaces.

WiFi/LAN(internally installed) GPRS (Optional)

The inverter has an interface for WiFi/GPRS/LAN/4G-Dongle that allow this device to collect information from inverter; including inverter working status, performance etc., and update that information to monitoring platform (the WiFi/GPRS/LAN/4G-Dongle is available to purchase from your local supplier).

Connection steps:

For GPRS device: Please insert the SIM Card (please refer to the GPRS product manual for more details).

Plug the WiFi/ GPRS/ LAN 4G-Dongle into “WiFi/GPRS/LAN 4G-Dongle” port at the bottom of the inverter.

For WiFi device: Connect the WiFi with the local router, and complete the WiFi configuration (please refer to the WiFi product manual for more details).

Set-up the site account on the monitoring platform (please refer to the monitoring user manual for more details).

APP Installation:

Scan the QR Code below to download and install the Cloud APP on your smartphone.



Configuration:

Note: The module is powered on and started, please wait for one minute to start the WiFi Config.

Web Configuration.

Step 1:

Connect your mobile device with Smart WiFi. The SSID of the Smart WiFi is 'W-xxxxxxx' and the password is 'mtmt2020' .

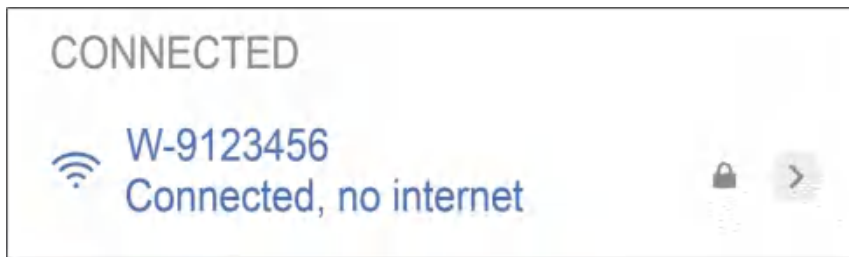

Step 2:

After connecting successfully. Open browser and enter 'https://192.168.1.1' on the address bar on top.

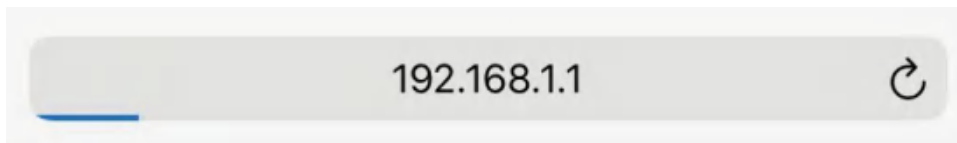

Step 3:

Drop down the WiFi SSID menu to find house router and input the house router's password. Click 'Save' .

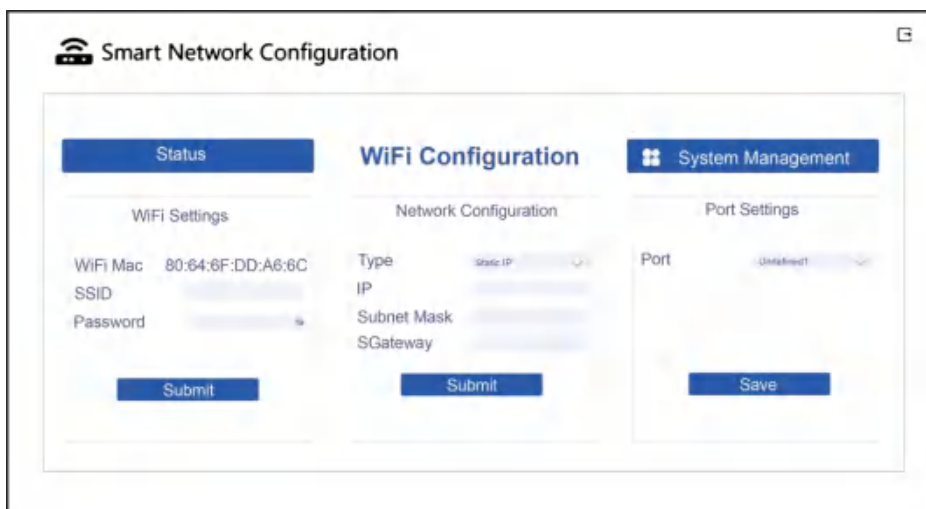

- RS485

RS485 is a standard communication interface which can transmit the real time data from inverter to PC or other monitoring devices.

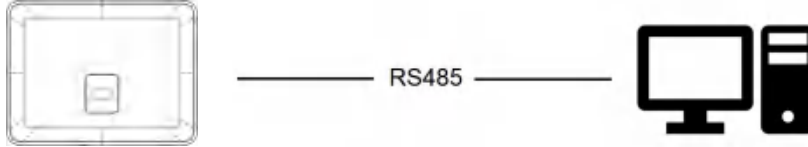

- Meter

The inverter has integrated export limitation functionality. To use this function, a power meter must be installed. For Meter installation, please install it on the grid side.

Note:

- Compatible Meter type: DTSU666 (CHINT).

Please check and configure the meter before use:

Addr: 1;

Baud: 9600

Protocol: n.1

Use the meter that comes standard in the box. Non-standard meters of the same model may not be suitable.

Please refer to the user manual of electricity meter for detailed setting steps.

Note!

When connecting the electricity meter, please make sure that the way of the electricity meter is correct, otherwise it will affect the size of the load obtained by the inverter and affect the normal operation of the inverter. When the battery is available and can work normally, the machine provides the self-test function in the direction of the meter, which can be set in the meter interface.

Export control setting:

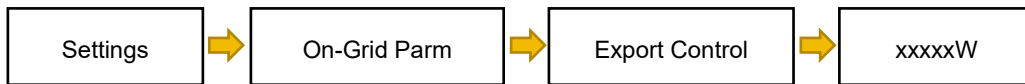

The electricity meter is connected as follows:

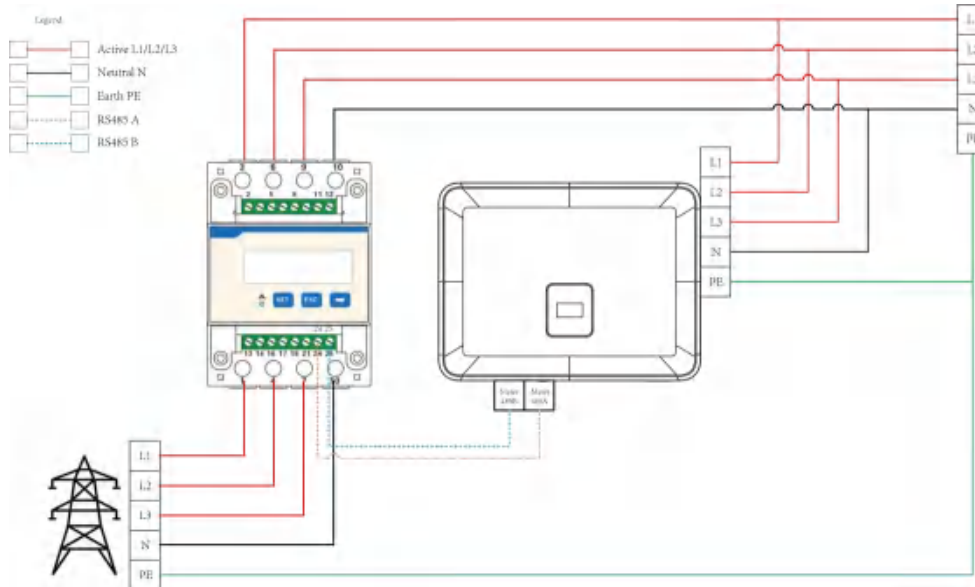

Meter connection:

Meter Connection Diagram

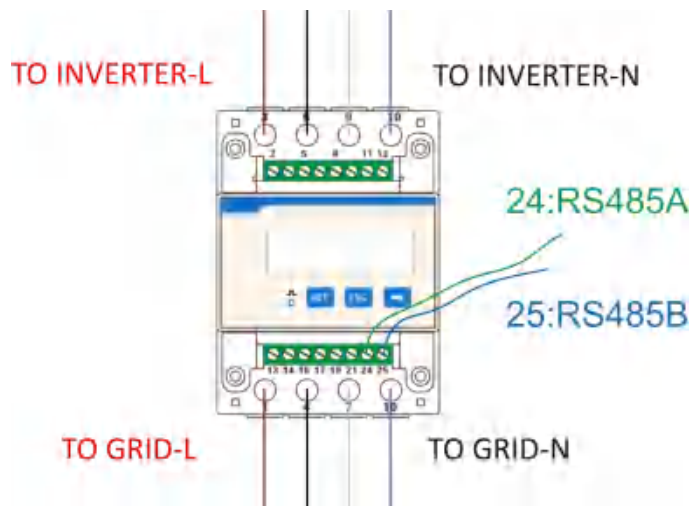

Hybrid Series Storage Inverter

CT-Meter Type

Step 1:

Insert L1/L2/L3/N wires, CT and RS485A/B cable into the meter. Please refer to the meter wiring diagram on side of meter itself. During CT use, the direction of the CT arrow faces the inverter.

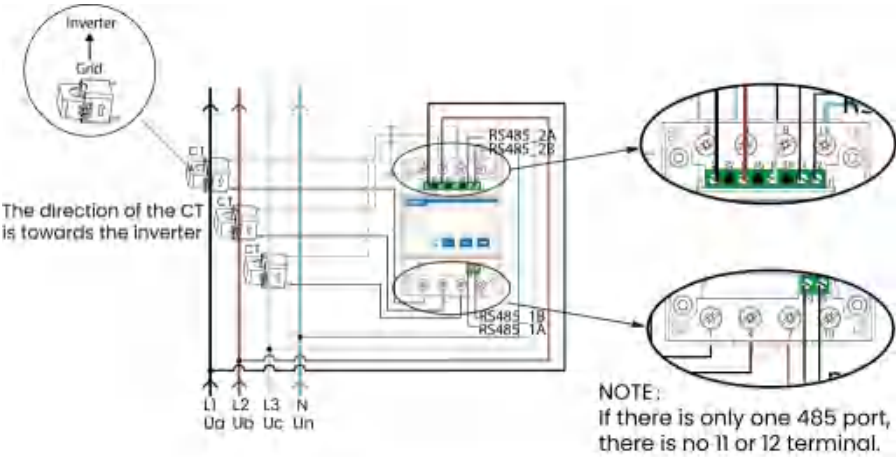
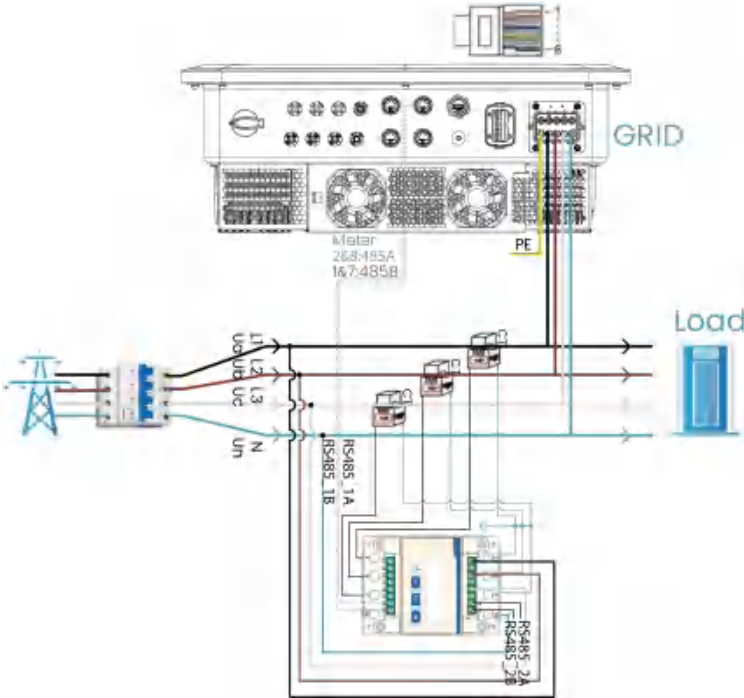

Hybrid Series Storage Inverter

6CT meter enables dual-meter functionality

Step 2:

A 6CT meter can be used to monitor the power output of an additional inverter or generation device.

Step 3:

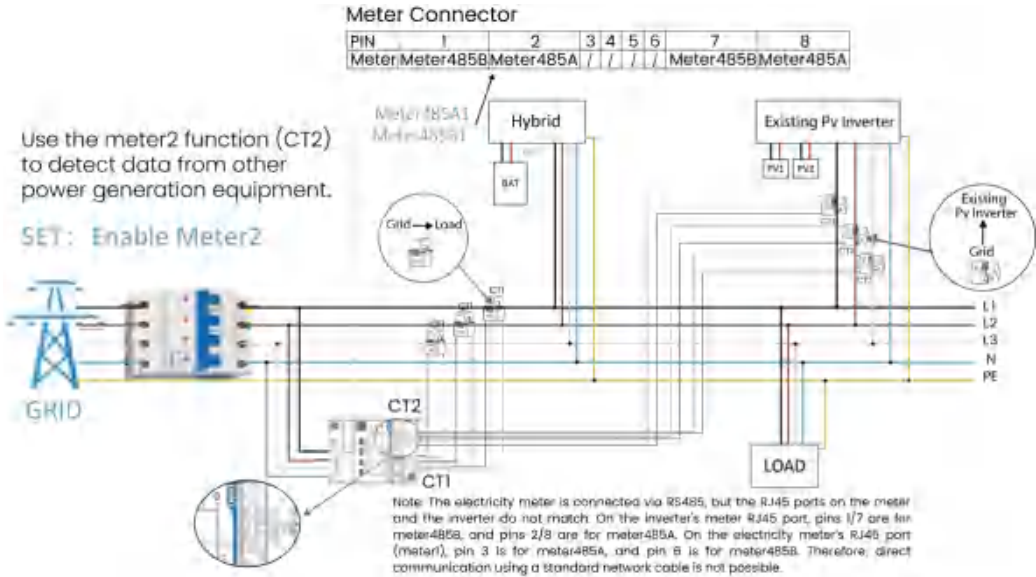

Note:

Need to enable meter2

Step4:

Connect RS485A to pin 2/8 of the inverter METER/RS485 port. Connect RS 485B to pin 1/7 of the inverter METER/RS485 port. Please use twisted pair cable.

Port \ PIN	1	2	3	4	5	6	7	8
Meter	meter 485B	meter 485A	/	/	/	/	meter 485B	meter 485A

Hybrid Series Storage Inverter

Step 5:

The transformation ratio setting of a CT meter needs to be consistent with the transformation ratio of a CT meter. The transformation ratio setting method for a CT meter is as follows:

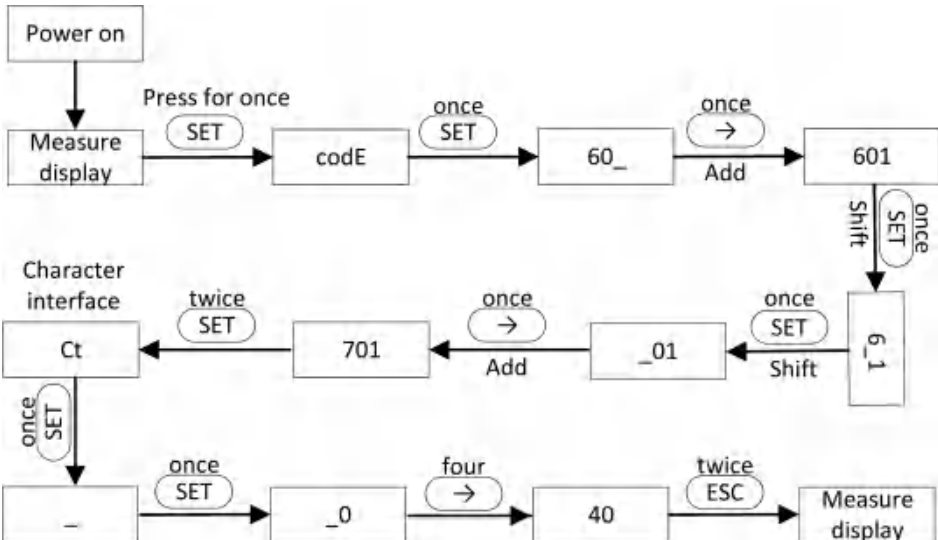

The address of the second meter is 2. Please ensure that the address is 2, otherwise the communication of the first meter will be affected, and the output and monitoring data of the inverter will be affected.

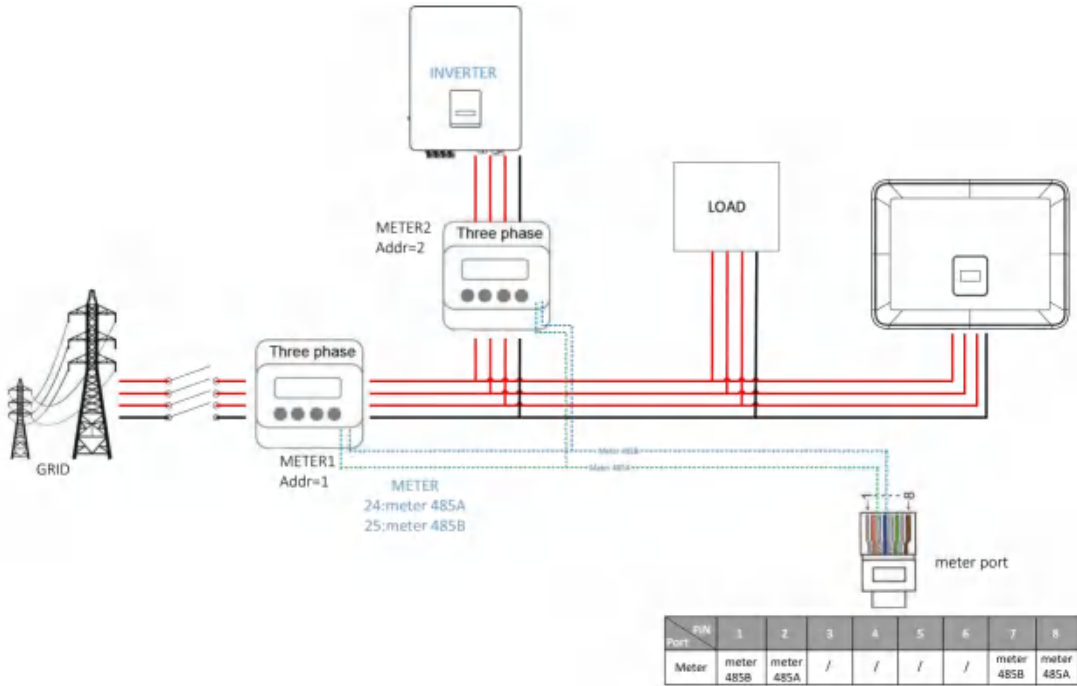

Hybrid Series Storage Inverter

• **DRM**

The definition of DRM port pin is as follows:

white rubber ring - old version DRM interface

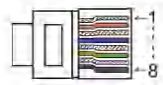

PIN Port	1	2	3	4	5	6	7	8
DRM	REF GEN/D	DRM1/5	DRM2/6	DRM3/7	DRM4/8	COM LOAD/D	GND	GND

Note: To achieve the DRM0 function, pins 1 and 6 need to be short-circuited.

The distributors will provide external adapter harnesses which function to convert the old pinout to the new pin definition.

Note: The old version of the pin requires an external adapter cable (P/N: 99-100-03722-00) to be compatible with GSD devices.

Red rubber ring - new version DRM interface

PIN Port	1	2	3	4	5	6	7	8
DRM	DRM1/5	DRM2/6	DRM3/7	DRM4/8	REF GEN/D	COM LOAD/D	GND	GND

Note: To achieve the DRM0 function, pins 5 and 6 need to be short-circuited.

Note: The new version supports the 568B cable standard and is directly compatible with GSD devices, eliminating the need for an external converter.

• **BMS**

BMS is used to communicate with the battery for data exchange, please use the network cable configured for the battery to communicate the communication distance should not exceed 10m.

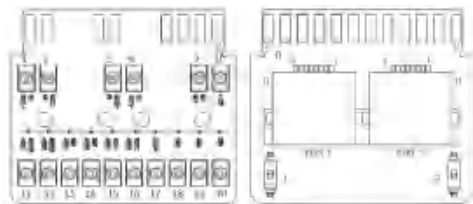

- Insert one side of CAT 7 cable into the first inverter's CAN port and the other side into the next inverter's CAN port.

- Insert one side of CAT 5 cable into the Meter port of meter, and the other side into the CAN 1 port the first inverter or the CAN 2 port of the last inverter.

Note: PV and battery should both be connected to the inverter with meter cable plugged.

Hybrid Series Storage Inverter

Introduction to the function of unbalanced load:

If the load of each phase in the household load is different, and the power of each phase output by the inverter is the same, there will be one phase output and one phase input. In order to avoid this situation, the unbalanced load can be turned on. The use method is to enable in the balance load interface.

The following is a simple schematic diagram of this function :

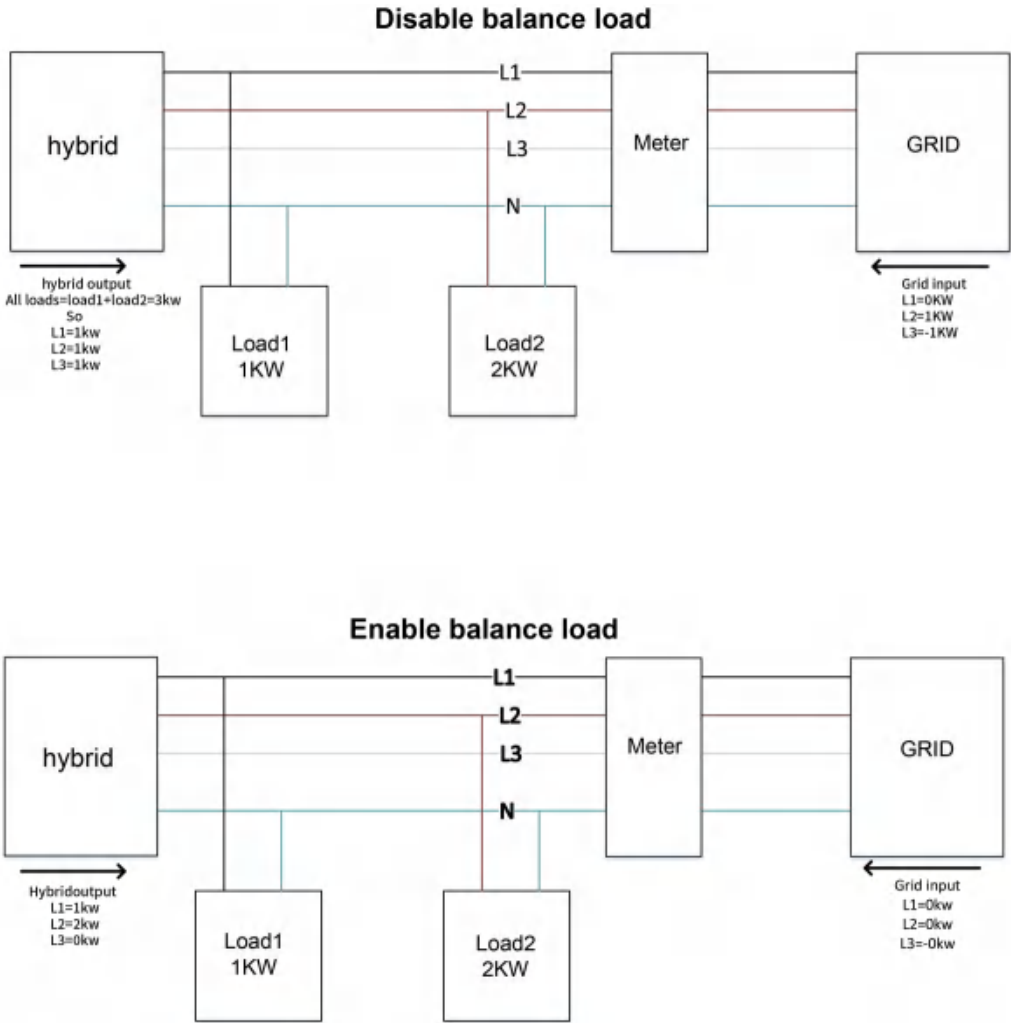

Note!

The maximum capacity of balanced load is 1/3 of the rated power, that is, the maximum output capacity of 12kW machine per phase is 4kW. The same is true for unbalanced load of off-grid function. If the single-phase load exceeds 1/3 of the output capacity under off-grid condition, the machine will report an error.

For countries such as **China, Germany, the Czech Republic, Italy, etc**, please follow local wiring regulations.
This diagram is an example for an application in which neutral is separated from the PE in the distribution box.

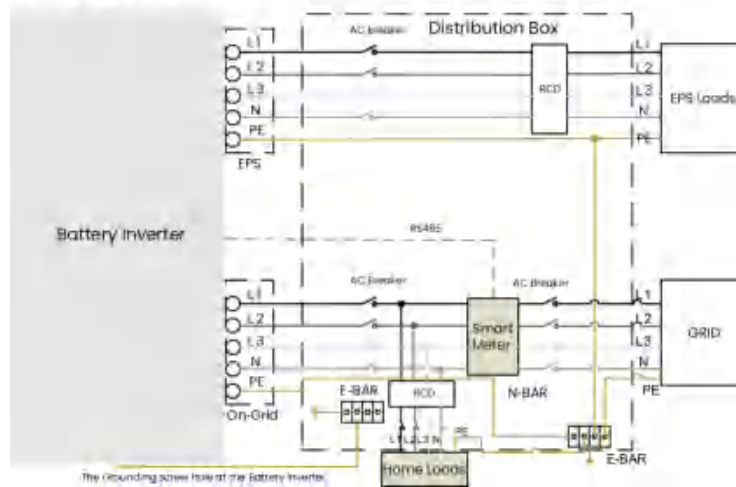

6.14 Inverter Start-Up

Please refer to the following steps to start up the inverter.

Ensure the inverter fixed well.

Make sure all the DC wirings and AC wirings are completed.

Make sure the meter is connected well.

Make sure the battery is connected well.

Make sure the external EPS contactor is connected well (if needed).

Make sure the BMS buttons and battery switches are off.

Turn on the PV/DC switch (for Hybrid only), AC breaker, EPS breaker and battery breaker.

Enter the settings page, default password is '0000', select START / STOP and set it to start. (long press "enter" to quickly go to the START / STOP page).

Note:

- When starting the inverter for the first time, the country code will be set by default to the local settings. Please check if the country code is correct.
- Set the time on the inverter using the button or by using the APP.

6.15 Inverter Switch Off

Please refer to the following steps to switch off the inverter.

1. Enter the settings page, select START / STOP and set it to stop.
2. Turn off the PV/DC switch (for Hybrid only), AC breaker, EPS breaker and battery breaker.
3. Wait 5 min before you open the upper lid (if in need of repair).

7 Main function implementation

7.1 Drm wiring

DRM0 setting

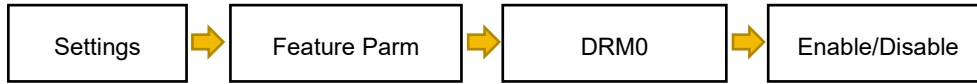

DRM supports several demand response modes by configuring control signals as below.

Mode	Asserted by shorting pins		Requirement
DRM0	5	6	Operate the disconnecting device, under Australian safety regulations.
DRM1	1	6	Do not consume power.
DRM2	2	6	Do not consume at more than 50% of rated power.
DRM3	3	6	Do not consume at more than 75% of rated power and source reactive power if capable.
DRM4	4	6	Increase power consumption (subject to constraints from other active DRMs).
DRM5	1	5	Do not generate power.
DRM6	2	5	Do not generate at more than 50% of rated power.
DRM7	3	5	Do not generate at more than 75% of rated power and sink reactive power if capable.
DRM8	4	5	Increase power generation (subject to constraints from other active DRMs).

Note: Currently only supports DRM0 function, other functions are under development.

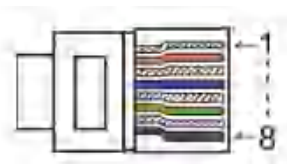

Port \ PIN	1	2	3	4	5	6	7	8
Ethernet	+3.3V	DRM1	DRM2	DRM3	DRM4	DRM0	GND	GND

7.2 RCR wiring

RCR setting

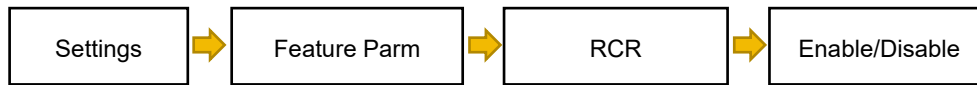

The prerequisite for the use of this function is the selection of the German grid connection regulation VDE 4105 and the use of the RCR function.

On the web page, first determine if the safety regulations are correct.



The settings for ripple control are as follows on the web page.

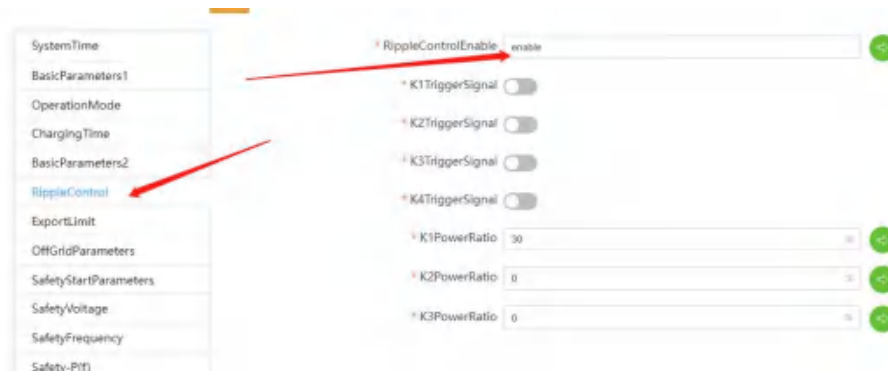

Firstly make sure that the ripple control Enable switch is in the Enable state, which indicates that the ripple control function has been turned on. The following K1-K4 Trigger signals function to display the status of ripple control, and K1-K3 power ratio indicates the corresponding power ratio.

For example, when DRM1 and +3.3 V are externally short-circuited, K1TriggerSignal will trigger and Limit the power to 30%.

When K4 is enabled, that is, when DRM4 and +3.3 V are short-circuited, the machine will be off-grid.

For the function of 14a under German safety regulations, there are two ways to operate: hardware and Software. This is the 14a function via the web page, limiting the input power to 4.2kW.

Hybrid Series Storage Inverter

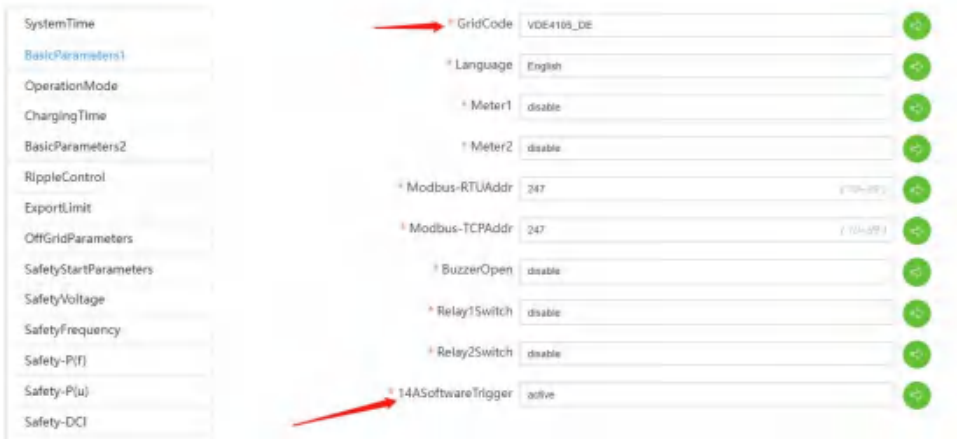

When realizing this through hardware, you need to change the setting in the setup to And external hardware short-circuits DRM0 and +3.3V.

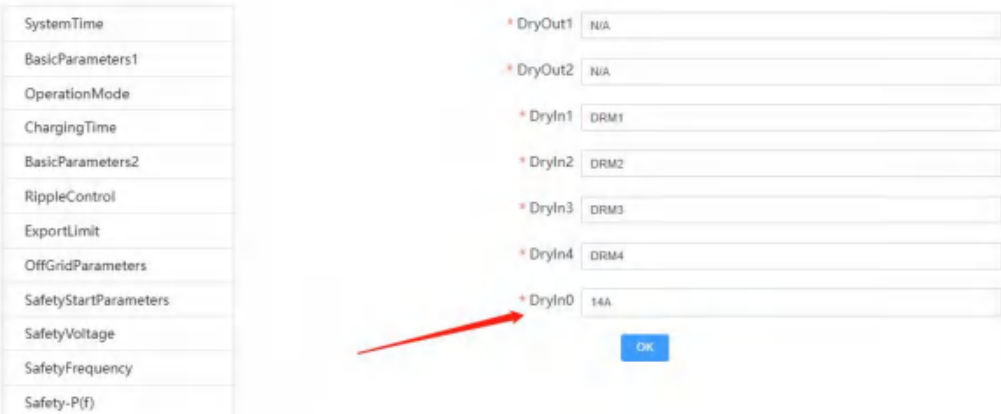

The ripple control function is described below:

PIN	1	2	3	4	5	6	7	8
Ethernet	+3.3V	DRM1	DRM2	DRM3	DRM4	DRM0	GND	GND

Switching state	Output active power (%Pn)
No contact closed	100%
Several contacts closed	100%
Contact DRM1 to +3.3V	60%
Contact DRM2 to +3.3V	30%
Contact DRM3 to +3.3V	0%
Contact DRM4 to +3.3V	Immediate OFF
Contact Drm0 to 3.3V	AC Max.Chr power limit to 4.2kw under Vde4105 Safty

7.3 SG ready wiring and setting

- **SG Ready**

The Smart Grid Ready is controlled by the dry contact output 1 of the inverter.

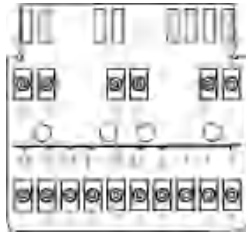

	Relay-1	
Label	DRY_RLY1-	DRY_RLY1+
Mode 1	0	
Mode 2	1	

Note: 0-Relay open, 1-Relay closed

Mode 1-Normal operation (0):

The heat pump runs in energy-efficient normal mode.

Mode 2-Encouraged operation (1):

The operation of the heat pump is encouraged to increase electricity consumption for heating and warm water.

The controller has 1 control models:

The heat pump is switched on.

The heat pump is switched on AND the warm water temperature is raised.

Configure DRY1 as SGready1

DryConfigure setting: DryConfigure Set the DryOut1 to SgReady-1.

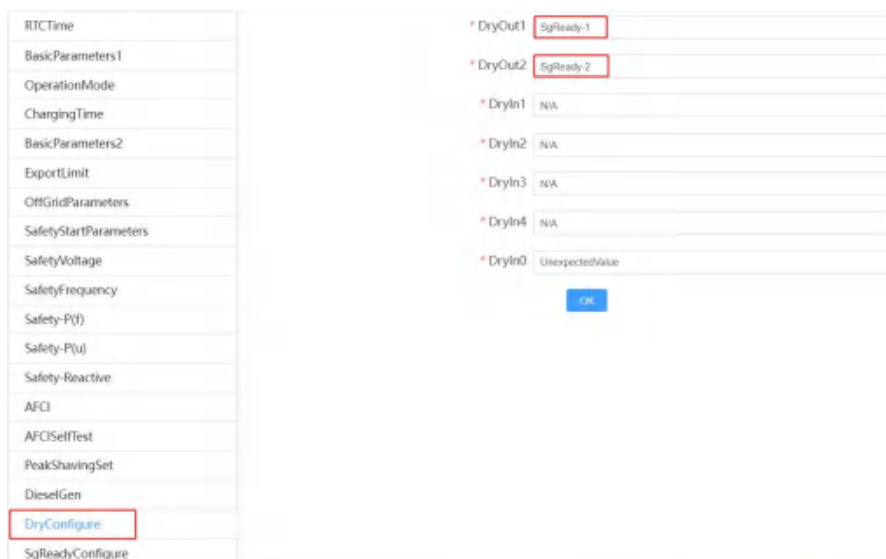

Configure SG ready power management settings

* SgReadyFunction	Disable
* RestartTime	0 <small>(0-65535)s</small>
* SgReadyStartPower	0 <small>(-60000-60000)W</small>
StartPower should be 5000W or more larger than StopPower	
* SgReadyStopPower	0 <small>(-60000-60000)W</small>

* SgReadyFunction: Disable/Enable sgreedy function.

* RestartTime: Interval between two launches of sgreedy.

* SgReadyStartPower: when the feed-in power exceeded the set value, the heat pump starts operation.

* SgReadyStopPower: When the feed-in power is less than the set value, the heat pump stops operation.

Note: Zero-feed-in system, if the pv-generation achieves a predefined value (Mode3), The heat pump will start automatically.

7.4 Reactive Function Setting

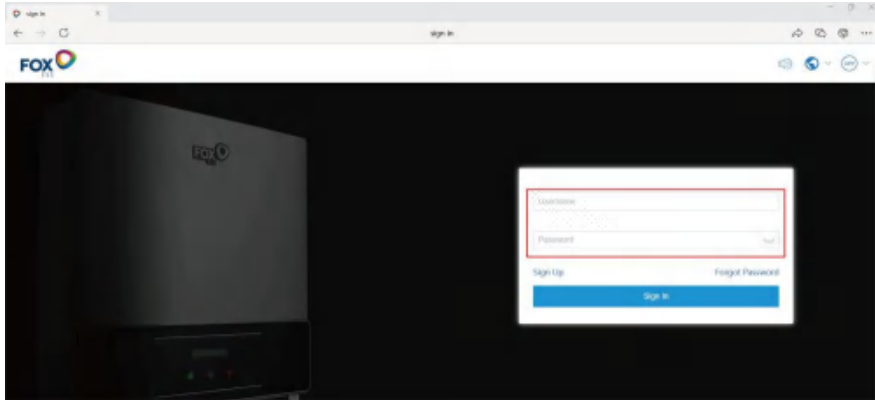
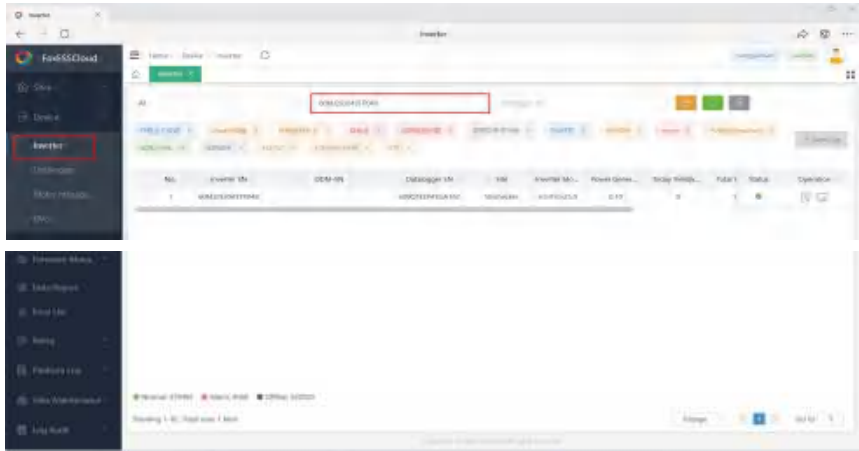
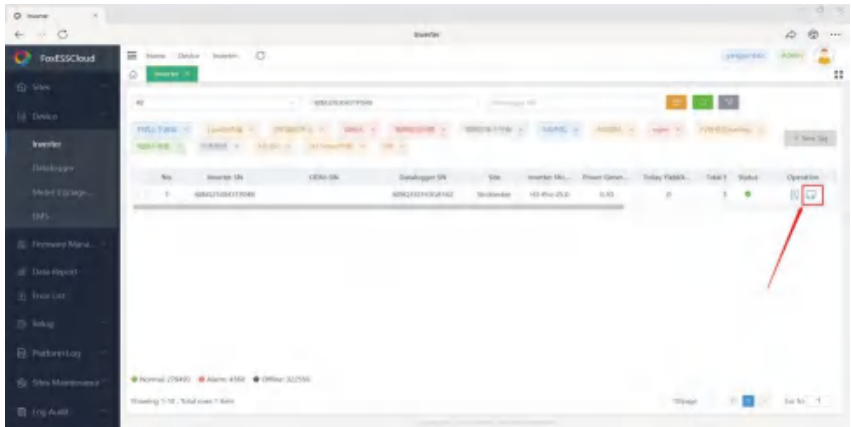
Procedures	
<p>Step 1</p>	<p>Login fox Cloud</p> 
<p>Step 2</p>	<p>Enter SN of Inverter</p> 
<p>Step 3</p>	<p>Click Here</p> 

Step 4

Click Safety-Reactive, Select the Reactive Power Mode Enable button.

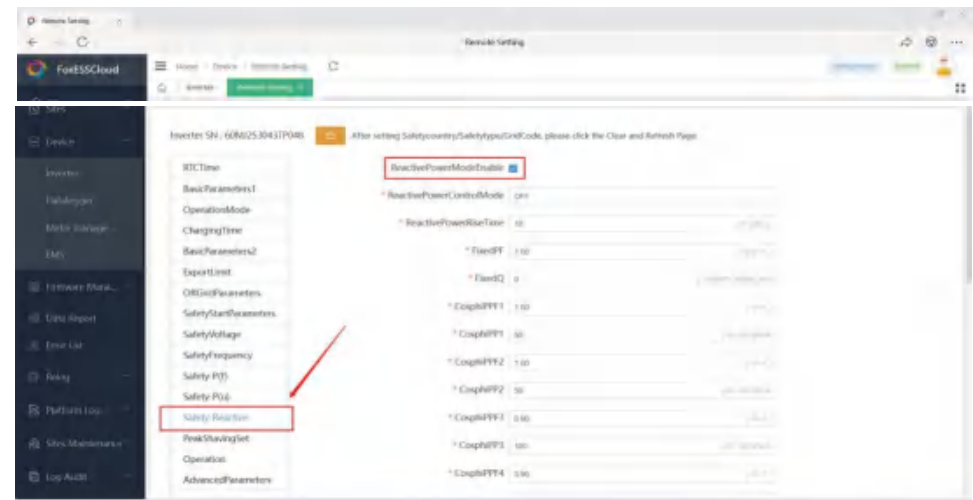

1. Fixed PF Over

If you want set the fix PF over, Find the Reactive PowerControl Mode dropdown menu and select the FixedPFOver option;

Set fixed PF parameters according to your needs, with a default value of 1;

ReactivePowerControlMode: FixedPFOver
 ReactivePowerRiseTime: 10
 FixedPF: 1.00

2. Fixed PF Under

If you want set the fix PF Under, Find the Reactive PowerControl Mode dropdown menu and select the FixedPFUnder option;

Set fixed PF parameters according to your needs, with a default value of 1;

ReactivePowerControlMode: FixedPFUnder
 ReactivePowerRiseTime: 10
 FixedPF: 1.00

3. P and cosφ function setting

If you want set the P and cosφ, Find the Reactive PowerControl Mode dropdown menu and select the cosφ (P);

You only need to set the following parameters (CosphiPPF1-4,CosphiPP1-4) according to your needs;

ReactivePowerModeEnable:
 ReactivePowerControlMode: cosφ(P)
 ReactivePowerRiseTime: 10
 FixedPF: 1.00
 FixedQ: 0
 CosphiPPF1: 1.00
 CosphiPP1: 50
 CosphiPPF2: 1.00
 CosphiPP2: 50
 CosphiPPF3: 0.90
 CosphiPP3: 100
 CosphiPPF4: 0.90
 CosphiPP4: 100

4. Fixed Q

If you want set the fix Q, Find the Reactive PowerControl Mode dropdown menu and select the FixedQ option;

Set fixedQ parameters according to your needs;

ReactivePowerModeEnable

* ReactivePowerControlMode

* ReactivePowerRiseTime (0-500)s

* FixedPF (0.8-1)

* FixedQ (-30000-30000)Var

5. Q and U function setting

If you want set the Q and U, Find the Reactive PowerControl Mode dropdown menu and select the Qu;

You only need to set the following parameters (QuV1-4,QuQ1-4) according to your needs;

ReactivePowerModeEnable

* ReactivePowerControlMode

* QuV1 (200-300)V

* QuQ1 (-50-50)%

* QuV2 (200-300)V

* QuQ2 (-50-50)%

* QuV3 (200-300)V

* QuQ3 (-50-50)%

* QuV4 (200-300)V

* QuQ4 (-50-50)%

7.5 Implementation of dual-channel EPS function

Note!

Note: For the dual-channel EPS function required in some areas, in the off-grid situation, it can allow The customers to turn on and turn off the off-grid additional loads, and provide the settings. of turning on and turning off by adjusting the battery capacity.

Wiring diagram for dual EPS

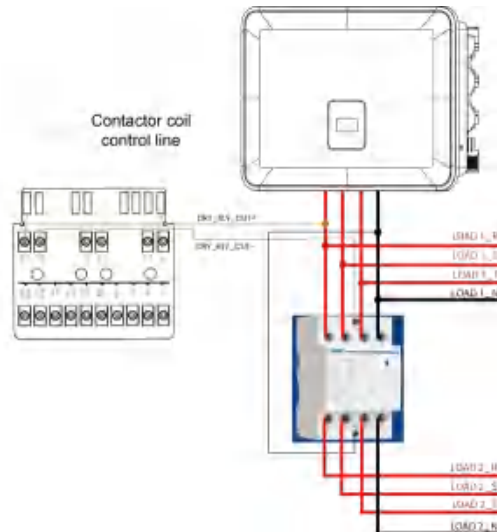

Load1 is directly connected to the EPS port and only loses power when the EPS stops outputting. Load2 is connected after the contactor and will shut off once the SOC drops below a certain level, causing the contactor to disconnect.

Contactor disconnected SOC parameter: SOC _ split

Contactor connected SOC parameter: SOC _ return

Relationship: $\text{min soc} < \text{soc_split} < \text{soc_return} < \text{max soc}$

Difference: SOC _ return between SOC _ split is at least greater than 10%

Contactor disconnected Logic:

In EPS mode: $\text{SOC} < \text{SOC_split}$

Contactor connected logic:

1. In EPS mode: $\text{SOC} > \text{SOC_return}$

2. In the case the grid is on or restored and the bypass relay is connected,

eg:

Set SOC _ split = 60%, SOC _ return = 80%

It means that in EPS mode, if the current SOC drops below 60%, disconnect the relay and the Load 2; if the current SOC returns to more than 80%, connect the relay and the Load 2 or connect the relay when the power grid is restored.

The setting interface: Feature----Dry Contact Ctrl-----Dry1-----1.Smart Load Ctrl-----

Function ON (Yes/No) / SOC OFF / SOC Restore

7.6 Parallel connection wiring and operating instructions

Each H3 Smart series system support Max. 10 units parallel connection for on-grid system or Max.

4 units parallel connection for off-grid system.

1) Parallel System Diagram

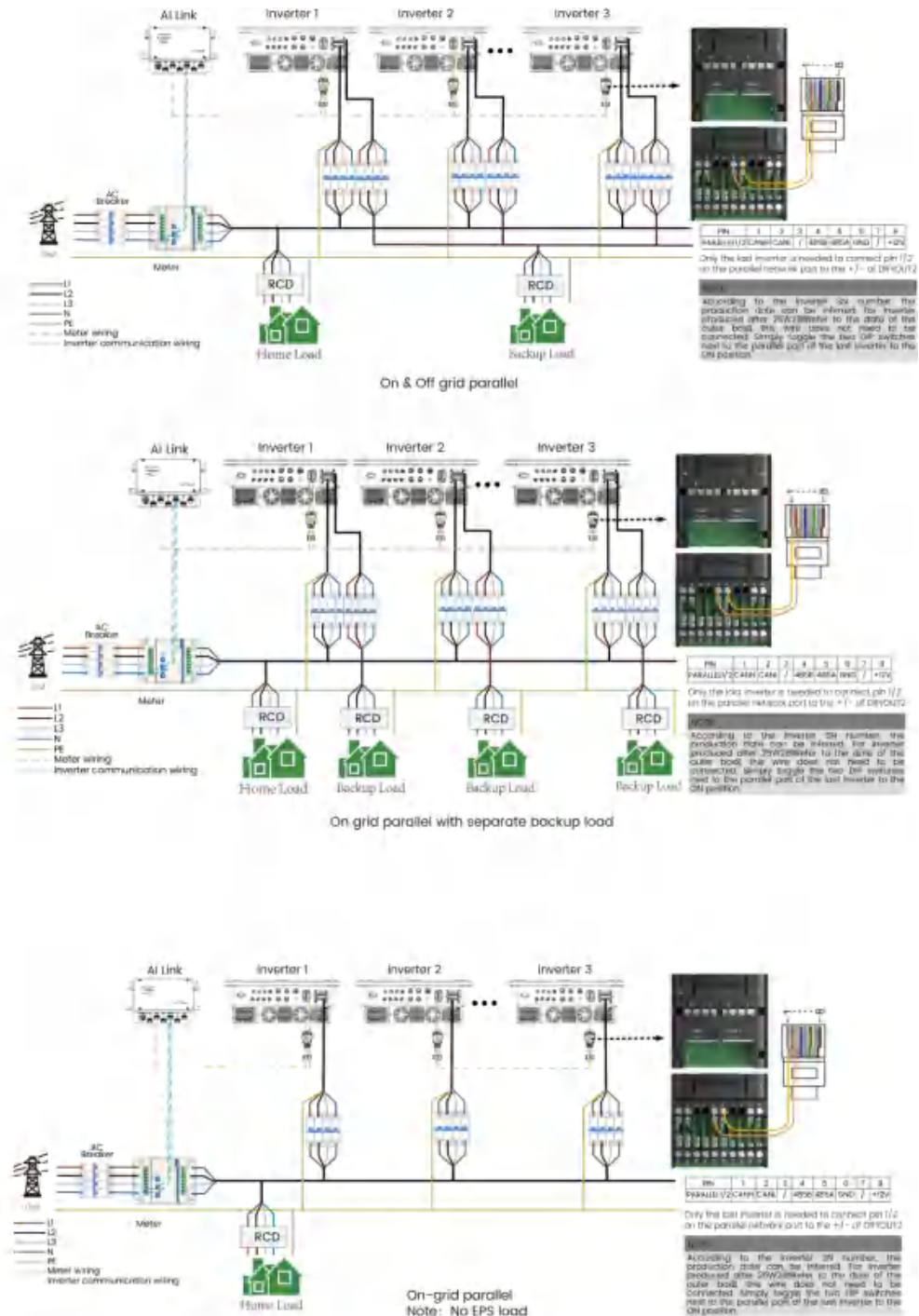

Hybrid Series Storage Inverter

Note:

- 1) Parallel inverters need to be of the same type and same version of software.
- 2) For "On grid parallel with EPS load" , "On&off grid parallel " scene, each inverter must be connected to the battery.
- 3) The cable length from each inverter's grid port to the grid connection point must be the same, and the cable length from each inverter's EPS port to the common load connection point must also be the same.

2) Parallel + 2 meter system diagram

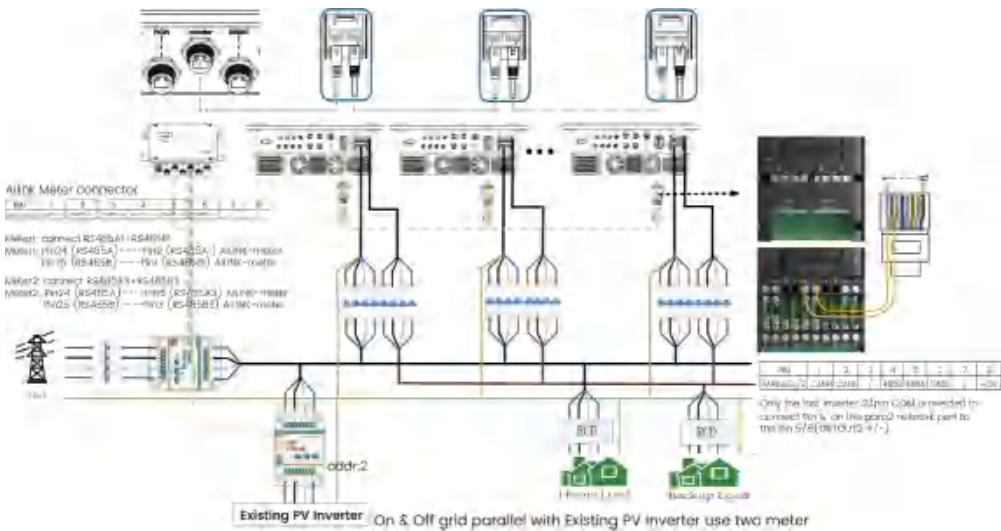

Note:

Only the electric meter is included in the accessory packing list. If the meter2 function is required, it needs to be purchased separately.

Modify the flowchart for "addr". The flowchart is as follows:

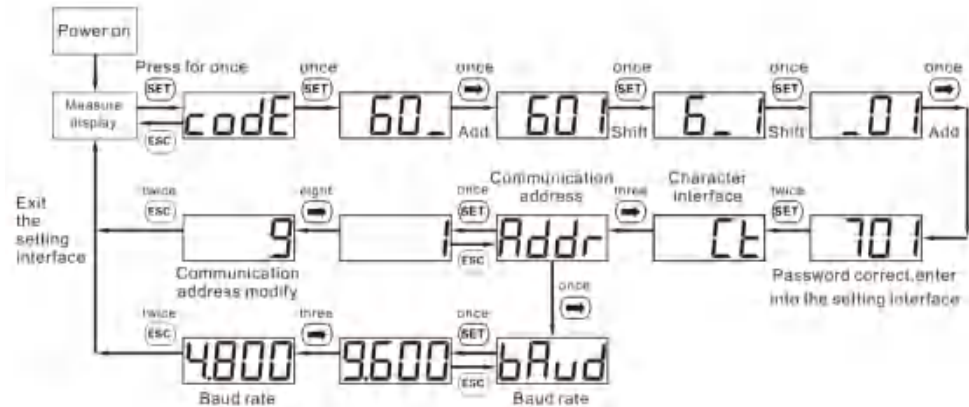

3) parallel +meter2 with 6CT meter

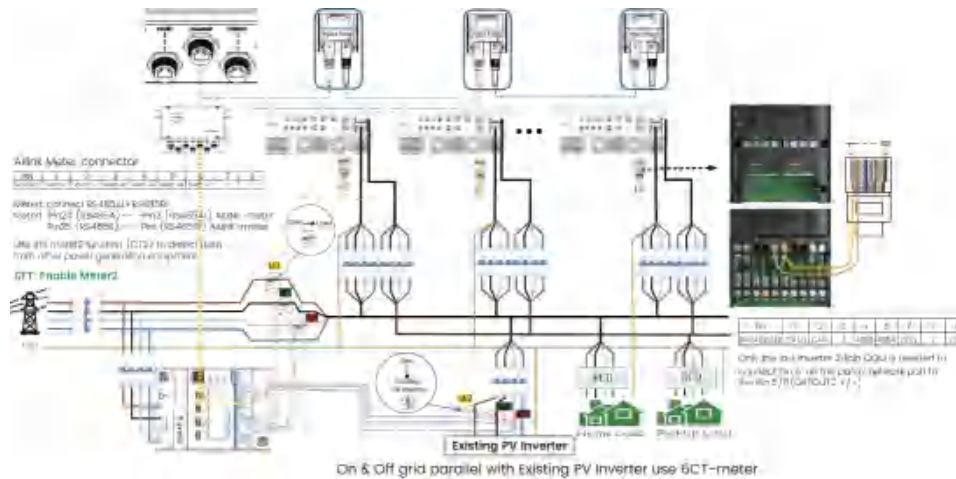

Note:

The black power line is connected: the meter terminals L1, **IA1** and **IA2** should be clamped to the **black** wire.

The brown power line is connected: the meter terminals L2, **IB1** and **IB2** should be clamped to the **brown** wire.

The gray-white power line is connected: the meter terminals L3, **IC1** and **IC2** should be clamped to the **gray-white** wire.

Note:

Need to enable meter2

Method for Checking the Correctness of CT Wiring

In the web-based settings, there is a "meter/CtDetection" interface. On this interface, there is a "DetectionEnable" option. After clicking it, the inverter will automatically check the phase and direction of meter1. The inspection result will be displayed, and you can also set and change the direction of the CT.

Local Testing Wiring Method:

Use the AC voltage range of a multimeter to test.

Whether the voltages on the wire of L1 on the electricity meter and the CT (Current Transformer) wire with the **yellow** sleeve are at the same potential;

Whether the voltages on the wire of L2 on the electricity meter and the CT wire with the **green** sleeve are at the same potential;

Whether the voltages on the wire of L3 on the electricity meter and the CT wire with the **red** sleeve are at the same potential.

4) Wire Connection

Step1 Parallel Power wiring

Please select the corresponding power wiring method according to different scenarios. The connection method and operation precautions for AC, battery, and PV shall refer to the quick installation manual of the standalone unit.

Step2 Inverter communication wiring

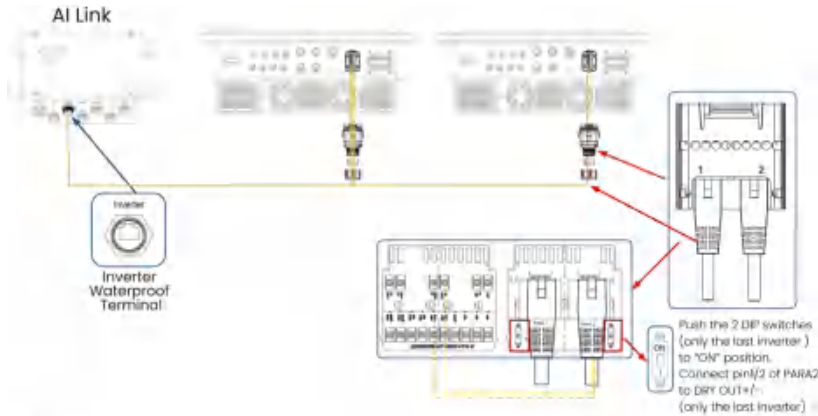

Note.

For the communication cable connecting the AI to the inverter: the length should not exceed 5 meters.

For the communication cable between inverters: the length should not exceed 10 meters.

For products with a production date before Week 28 of 2025 (25W28): It is required to connect Pin 1/2 of Para2 in the COM port of the last inverter to Pin 5/6 of the COM port.

Step3 Meter wiring

AI Link Meter Connector Pin Definition

PIN	1	2	3	4	5	6	7	8
Meter/485	RS485-B1	RS485-A1	RS485-B3	RS485-A4	RS485-B4	RS485-A3	/	/

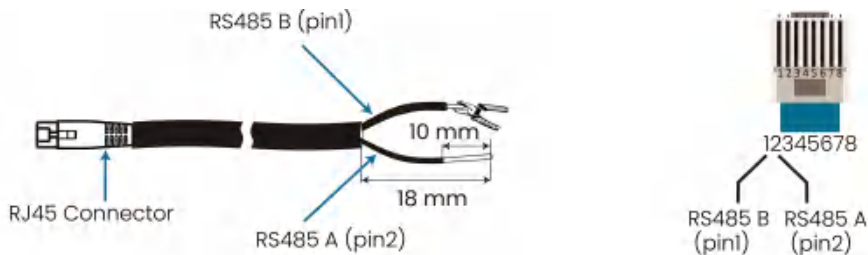

Hybrid Series Storage Inverter

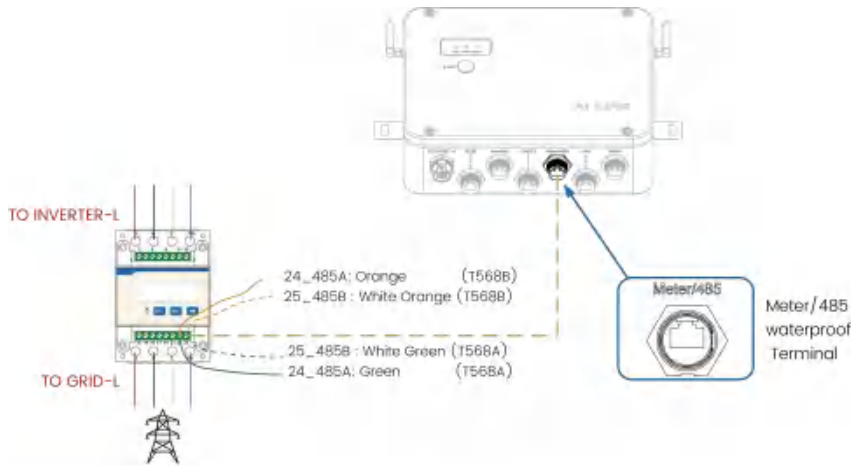

Note:

Grid-side inflow/outflow current < 80A, meter can be connected directly.

Wiring Table between the AI Link and the Meter

	AI Link	Meter (CHINT DTSU666)
RS485 A	Pin2 (Meter/485, RS485- A1)	Pin24
RS485 B	Pin1 (Meter/485, RS485- B1)	Pin25

CT meter needs to be purchased separately, if required. The meter's part number is 30-803-00038-00. The CT for this meter is not standard and can be selected according to the customer's actual requirements.

CT Meter wiring Diagram:

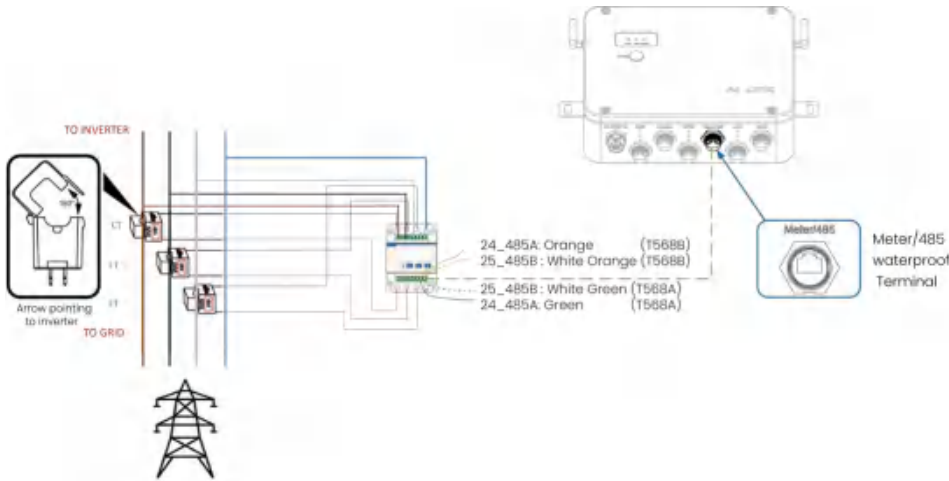

Note:

Grid-side inflow/outflow current > 80A, use Current Transformer.

6CT meter wiring

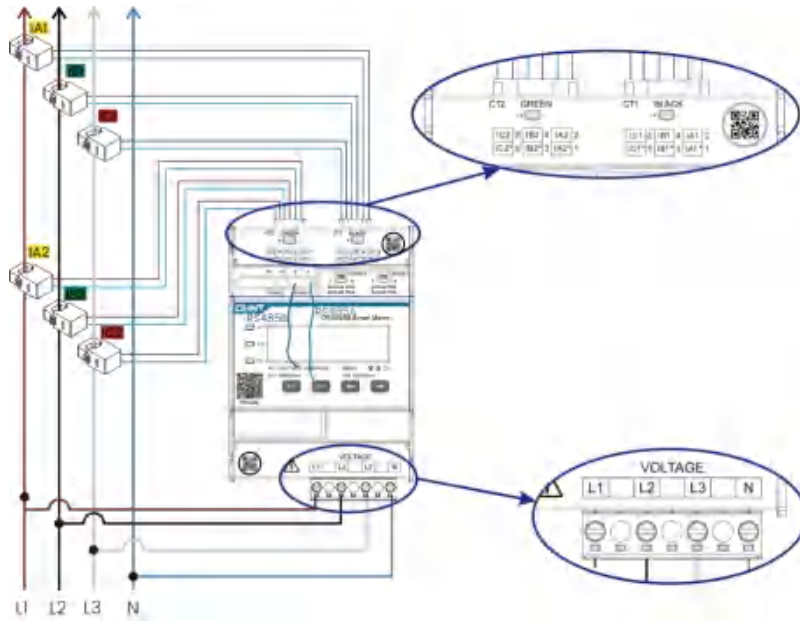

Note!

Grid-side inflow/outflow current > 80A, use Current Transformer.



5) APP Configuration Reference



Please download the FoxCloud2.0 APP from Apple store or Google store.



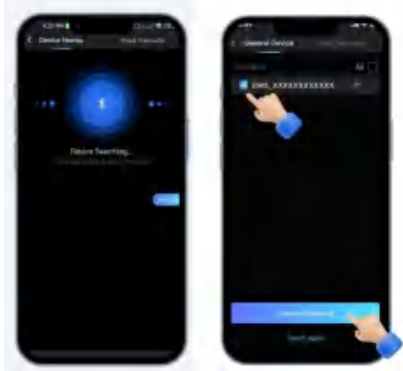

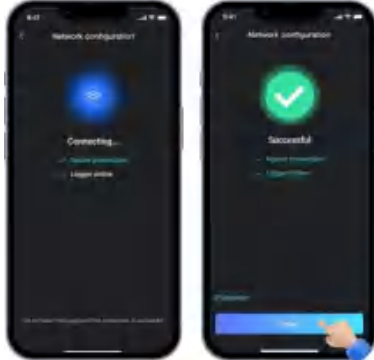

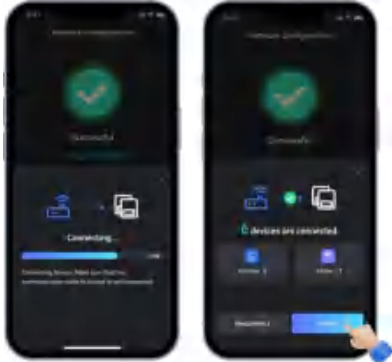
Note!

Make sure all communication cables between AI Link and inverters are connected.
 Make sure all inverters and smart logger are powered on.

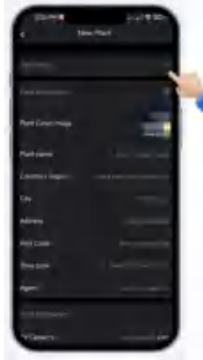
Procedures		
Step 1	<p>Connect to network</p> <p>1-1 Open APP, then click three point in the top right corner of login page, and choose "WLAN Configuration".</p>	
	<p>1-2 Keep Bluetooth on and wait for device searching. Then choose the device (EMS_XX XXXXXXXX) and click "Connecting Network".</p>	
	<p>1-3 Choose SSID of home router and enter password, then click "Next".</p>	
	<p>1-4 Wait for about 30s, it will complete the configuration. Then click "Finish".</p>	

<p>Step 2</p>	<p>Connect to device Then it will start communicate with devices automatically. Please wait for 30 seconds. Then click "Finish".</p> <p>Please check whether the number of devices is consistent with the actual number. If not, please click "Reconnect" or confirm the cable connection is correct.</p>	
<p>Step 3</p>	<p>Choose your scene Select a scene based on the onsite cable connection. Then click "Confirm".</p> <p>It means the network configuration and settings of AI Link are both successful. Then click "Got it", it will turn to login page.</p>	
<p>Step 4</p>	<p>Sign in Enter your username and password, and click "sign in".</p>	

	<p>Create a plant</p> <p>5-1</p> <p>Click “Create a plant”.</p>	
<p>Step 5</p>	<p>5-2</p> <p>Click “Add Device “</p>	
	<p>5-3</p> <p>Scan the SN of EMS logger, and click “Confirm”.</p>	
	<p>5-4</p> <p>Enter the basic information, and click “Save”.</p> <p>It will turn to homepage.</p>	

<p>Step 6</p>	<p>Wait and refresh It may need to wait for 3-5 minutes to upload inverters data, please be patient. You can swipe to refresh this page.</p>	
<p>Step 7</p>	<p>Check device Click the rotating ring to go to the parallel page. Check if all devices are shown well.</p>	

6) Steps Required for Allink Upgrade

To pair AILINK with H3 Smart, the version of AILINK must be 2.0 or higher. Below is the update instructions.

AI Link 2.x Remote Upgrade

Operation instructions for AI Link's remote upgrade from 1.x to 2.x and in-version upgrade within 2.x via the platform are briefly summarized as follows:

Upgrade the slave.

Firmware name: smartLogBox Slave V0.04

Upgrade the master.

Firmware name for GM/GA: smartLogBoxMasterGV2.0.13

Firmware name for GW: smartLogBox Master V2.0.13

Upgrade the all-in-one.

Official release version or latest firmware name: smartLogBoxAllinoneV2.1.4

Or perform a local upgrade by connecting the local electricity meter to AILink. Please contact the local after-sales service for the upgrade file.

7) Allink enables the meter2 function

Instruction for Connecting Third-Party Devices to Electric Meters

1. Electricity Meter Selection

Chint-exclusive DTSU666 Three-Phase Electricity Meter.

2. Electricity Meter Connection Rules

The CT (Current Transformer) points to the power grid, with positive value for power generation.

3. Cloud Platform Settings (as follows)

3.1 Enter the EMS (Energy Management System) settings interface.



3.2 Select the actual connected port number.

For example: If connected to A3 and B3 as shown in the diagram, select RS485-3.

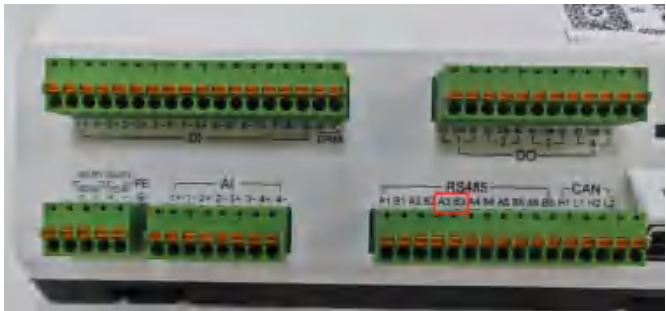

Hybrid Series Storage Inverter



3.3 Click "Add".



3.4 Query the electricity meter address.

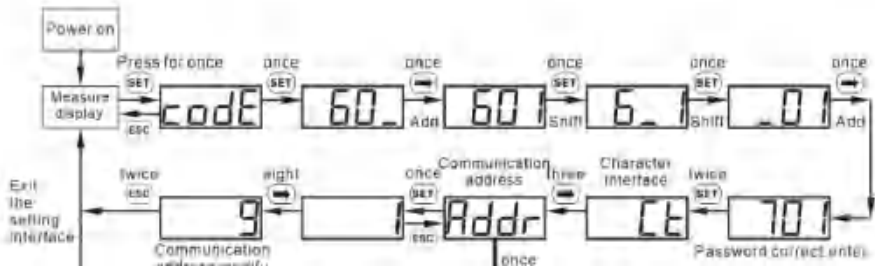

3.5 Enter information.

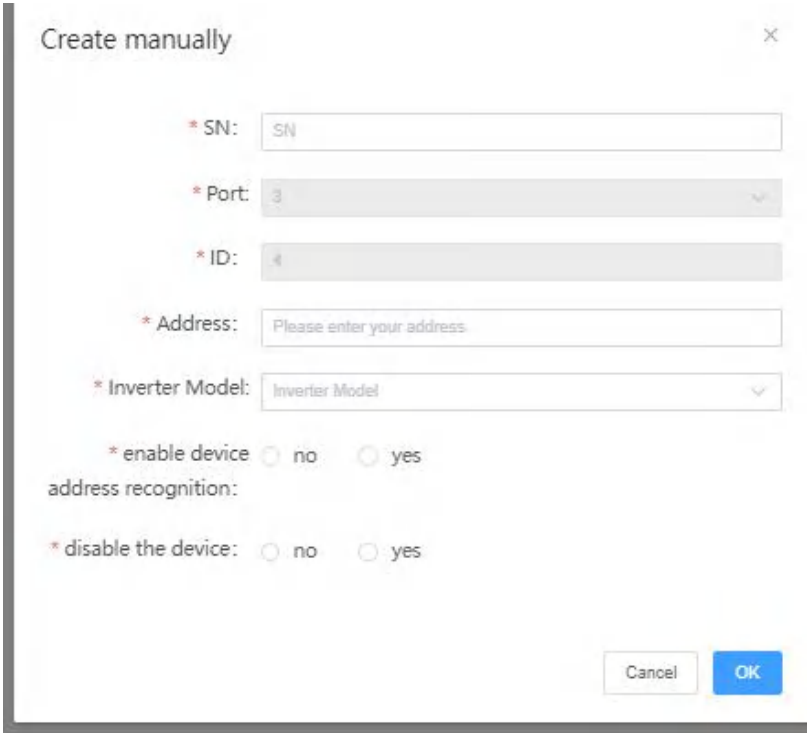

Create manually

* SN:

* Port:

* ID:

* Address:

* Inverter Model:

* enable device no yes

address recognition:

* disable the device: no yes

Cancel OK

Hybrid Series Storage Inverter

SN input rule: Replace the first 7 characters of the EMS SN with "MTRN104".

For example, if the EMS SN is 609K2E1F476A144, enter the SN as: MTRN104F476A144.

Address input rule: Enter the electricity meter address.

Inverter Model selection: Third Party Device.

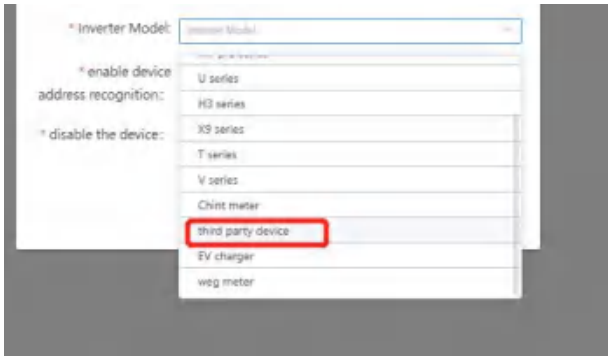

Other settings are as follows:

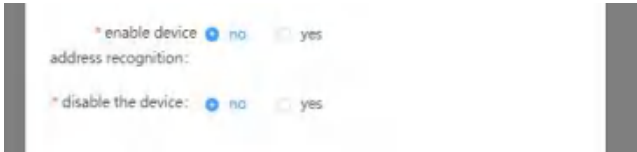

3.6 After completing the settings, click "OK".

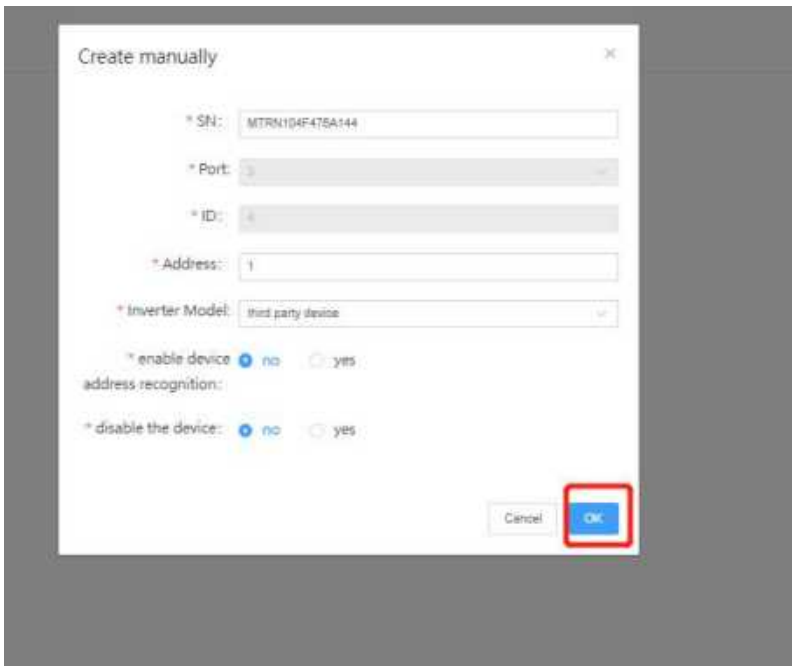

8 Firmware Upgrading

User can upgrade inverter's firmware via a U-disk.

- **Safety check**

Please ensure the inverter is steadily powered on.

Inverter must keep the battery on through whole procedure of upgrading. Please prepare a PC and make sure the size of U-disk is under 32G, and the format is fat 16 or fat 32.

⚠ Warning!

Caution!

Please DO NOT apply USB3.0 U-disk on inverter USB port, the inverter USB port only support for USB2.0 U-disk.

- **Upgrading steps:**

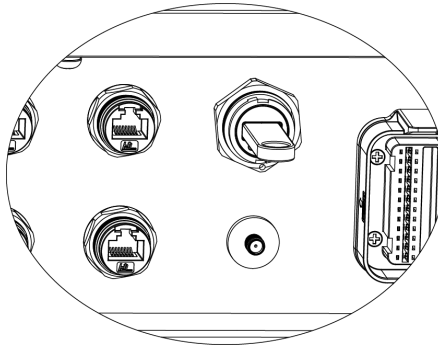
Procedures	
Step 1	<p>Please contact our service support to get the update files, and extract it into your U-disk as follow:</p> <p>update/master/ H3_G2_Smart_Master_Vx.xx.bin update/slave/ H3_G2_Smart_Slave_Vx.xx.bin update/manager/ H3_G2_Smart_Manager_Vx.xx.bin</p> <p>Note: Vx.xx is version number.</p>
	<h3>⚠ Warning!</h3> <p>Make sure the directory is in accordance with above form strictly! Do not modify the program file name, or it may cause the inverter not work anymore!</p>
Step 2	<p>Unscrew the waterproof lid and insert U-disk into the "USB" port at the bottom of the inverter.</p> 

Step 3	The LCD will show the selection menu. Then press up and down to select the one that you want to upgrade and press "OK" to confirm to upgrade.
Step 4	After the upgrade is finished, pull out the U-disk. Screw the waterproof lid.

- local upgrading:







USB Upgrade Operation Guide (Apply to Hybrid)

Introduction: The inverter is a high-tech integrated system with a CPU controller, which requires maintenance and upgrade. The upgrade is easy to operate with by end user or installer, upgrade files will be provided by manufacturer, please prepare everything ready before performing this upgrade.

*The same procedure is used for H1/AC1/Hybrid charger.

Preparations:

- 1) Prepare one USB 2.0 with memory less than 32G (USB 3.0 incompatibility)

 USB 2.0	 USB 3.0
★★★★☆ (385 ratings)	★★★★☆ (457 ratings)
	
Released April 2000	November 2008
Speed High Speed or HS, 480 Mbps (Megabits per second)	10 times faster than USB 2.0. Super Speed or SS, 4.8 Gbps (Giga bits per second)
Signaling Method Polling mechanism i.e can either send or receive data (Half duplex)	Asynchronous mechanism i.e. can send and receive data simultaneously (Full duplex)
 USB 2.0	 USB 3.0
Power Usage Up to 500 mA	Up to 900 mA. Allows better power efficiency with less power for idle states. Can power more devices from one hub.
Number of wires within the cable 4	9
Standard-A Connectors Grey in color	Blue in color
Standard-B Connectors Smaller in size	Extra space for more wires

Hybrid Series Storage Inverter

- 2) Install the USB disk on your laptop, open it and create a folder named 'update'
- 3) Create another three separate subfolders named 'manager' 'master' 'slave' under 'update' folder.
- 4) Put the upgrade file into corresponding folder as shown below

* Formate fo the file name: **Model_Firmware type_Vx_xx**

File names example:

U:\update\master\Hybrid_Master_Vx_xx

U:\update\slave\Hybrid_Slave_Vx_xx



U:\update\manager\Hybrid_Manager_Vx_xx

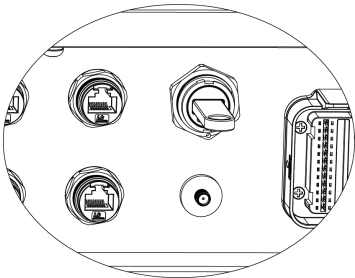

- 5) Prepare a slotted screwdriver for removing the upgrade portcover.

Upgrade procedure:

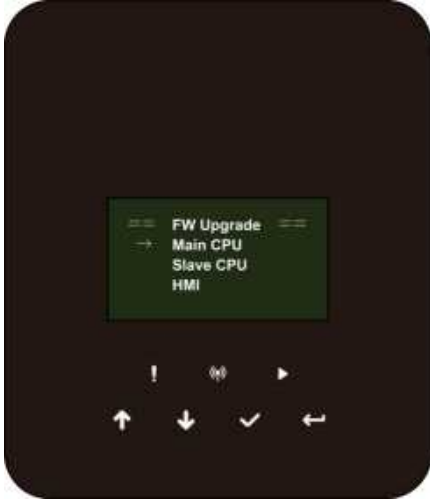
Procedures	
Step 1	Turn off AC breaker (main circuit breaker) firstly then turn off DC breaker, make sure the inverter is powered off.
Step 2	Remove the upgrade port cover with a screwdriver.
Step 3	<p>Plug in the USB disk.</p> 
Step 4	Only turn on DC breaker (make sure PV voltage is above 120V) wait for 10 seconds, the inverter screen will show as below:

	
	<p>If you want to upgrade the inverter firmware, click “up” or “down” to choose the targeted firmware, then click “enter” to start the upgrade. The upgrade will proceed like below:</p> <p>NOTE: Main CPU is “master”, Slave CPU is “slave”, HMI is “manager”.</p>
<p>Step 5</p>	
<p>Step 6</p>	<p>Remove the USB disk after upgrade completed. Follow the procedure below and click the option to view the version.</p>

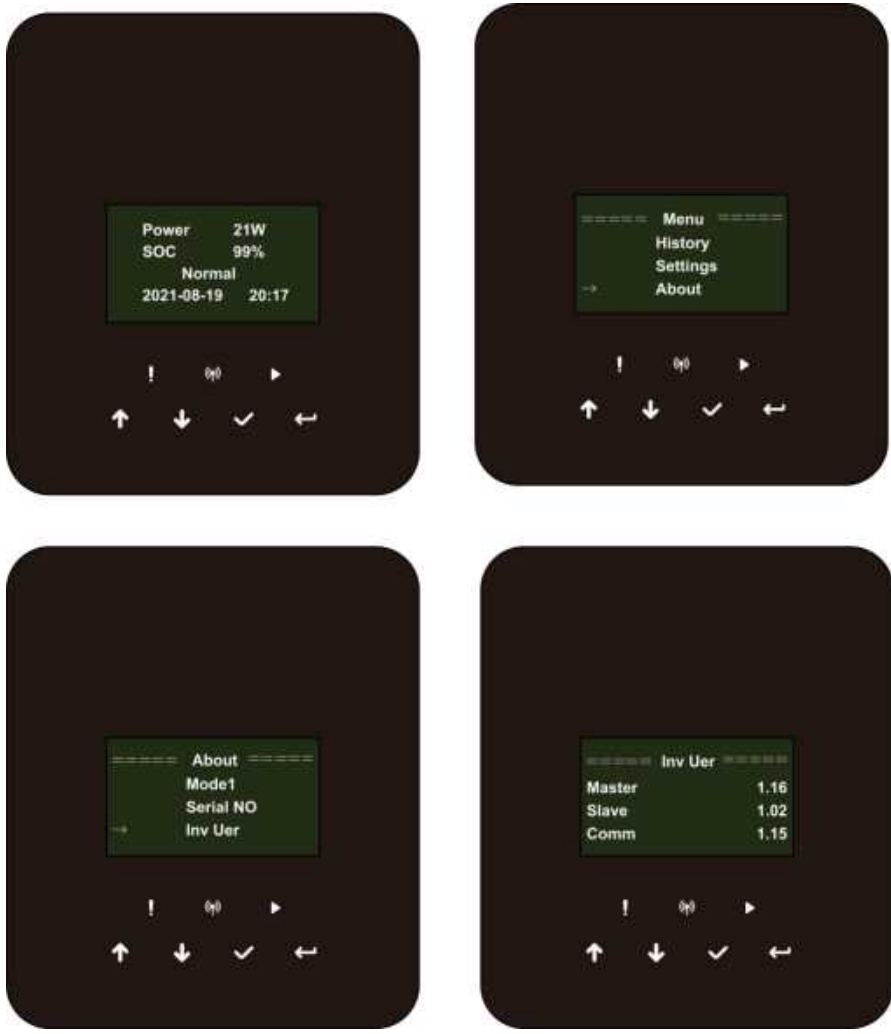
	<p>Menu -> About -> Inv Ver</p> 
<p>Step 7</p>	<p>Turn on AC &DC breaker. If you updated the HMI, long press the "enter" and click "set" to turn on the inverter. Make sure the inverter can enter Normal State.</p>

9 Operation

9.1 Control Panel

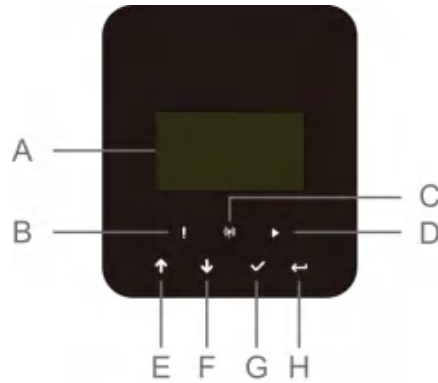

Object	Name	Function
A	LCD screen	Display the information of the inverter.
B	Indicator LED	Red: The inverter is in fault mode.
C		Blue: Light off- No network connection. Blink- connect to the internet. Light on- connection successful.
D		Green: The inverter is in normal state.
E		Function button
F	Down button: Move cursor to downside or decrease value.	
G	OK button: Confirm the selection.	
H	Return button: Return the previous operation.	

1. Press and hold the "√" button on the top of the screen and select "stop" to stop the machine.
2. Disconnect the AC and eps vacs.
3. Rotate DC SWITCH to the off state.
4. Turn off the buttons and control switches on the battery.
5. Wait for the screen on top of the machine to go off.
6. Wait for 15 minutes, this is to ensure that the capacitors inside the machine discharge.
7. Use a current clamp to make sure there is no current on the DC line.
8. Using the tool on the DC terminal, press the two snaps on the DC terminal and pull it outward with force at the same time.
9. Make sure there is no PV positive terminal and no voltage above the PV negative terminal, use a multimeter to measure.
10. Also use a multimeter to measure the PV positive and PV negative terminals to the PE line above the voltage no voltage.
11. Use a tool to disconnect the AC terminal and the terminal for communication.

9.2 Function Tree

- Single machine operation mode

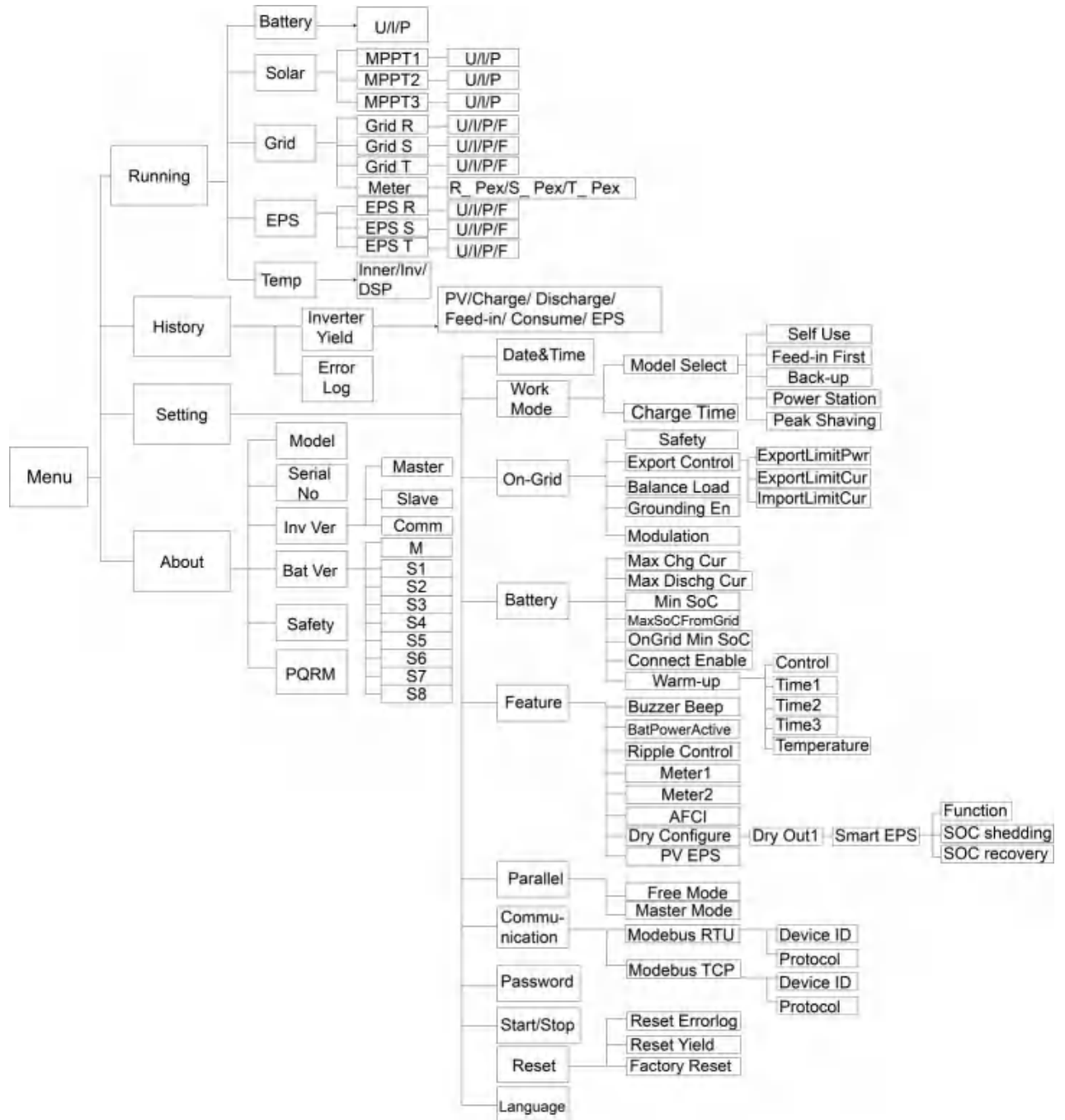

10 Maintenance

This section contains information and procedures for solving possible problems with the inverters and provides you with troubleshooting tips to identify and solve most problems that can occur.

10.1 Alarm List

Fault Code	Solution
Grid Lost Fault	Grid is lost. <ul style="list-style-type: none"> • System will reconnect if the utility is back to normal. • Or seek help from us, if not go back to normal state.
Grid Volt Fault	Grid voltage out of range. <ul style="list-style-type: none"> • System will reconnect if the utility is back to normal. • Or seek help from us, if not go back to normal state.
Grid Freq Fault	Grid frequency out of range. <ul style="list-style-type: none"> • System will reconnect if the utility is back to normal. • Or seek help from us, if not go back to normal state.
PLL_ OverTime	Three-phase system access single-phase AC. <ul style="list-style-type: none"> • System will reconnect if the utility is back to normal. • Or seek help from us, if not go back to normal state.
10min Volt Fault	The grid voltage is out of range for the last 10 Minutes. <ul style="list-style-type: none"> • System will reconnect if the utility is back to normal. • Or seek help from us, if not go back to normal state.
SW Inv Cur Fault	Output current high detected by software. To upgrade to the latest software, at least ensure that the master is upgraded to 1.69 or above. <ul style="list-style-type: none"> • Disconnect PV, grid and battery, then reconnect. • Or seek help from us, if not go back to normal state.
DCI Fault	DC component is out of limit in output current. <ul style="list-style-type: none"> • Disconnect PV, grid and battery, then reconnect. • Or seek help from us, if not go back to normal state.
HW Inv Cur Fault	Output current high detected by hardware. <ul style="list-style-type: none"> • Disconnect PV, grid and battery, then reconnect. • Or seek help from us, if not go back to normal state.
SW Bus Vol Fault	Bus voltage out of range detected by software. Please check whether the N line is connected to the GRID port of the inverter. To upgrade to the latest software, at least ensure that the master is upgraded to 1.69 or above. <ul style="list-style-type: none"> • Disconnect PV, grid and battery, then reconnect. • Or seek help from us, if not go back to normal state.

Hybrid Series Storage Inverter

Bat Volt Fault	<p>Battery voltage fault.</p> <ul style="list-style-type: none"> • Check if the battery input voltage is within the normal range. • Or seek help from us.
SW Bat Cur Fault	<p>Battery current high detected by software.</p> <ul style="list-style-type: none"> • Disconnect PV, grid and battery, then reconnect. • Or seek help from us, if not go back to normal state.
Iso Fault	<p>The isolation is failed.</p> <ul style="list-style-type: none"> • Please check if the insulation of electric wires is damaged. • Wait for a while to check if back to normal. • Or seek for help from us.
Res Cur Fault	<p>The residual current is high.</p> <ul style="list-style-type: none"> • Please check if the insulation of electric wires is damaged. • Wait for a while to check if back to normal. • Or seek for help from us.
Pv Volt Fault	<p>PV voltage out of range.</p> <ul style="list-style-type: none"> • Please check the output voltage of PV panels. • Or seek for help from us.
SW Pv Cur Fault	<p>PV input current high detected by software.</p> <ul style="list-style-type: none"> • Disconnect PV, grid and battery, then reconnect. • Or seek help from us, if not go back to normal state.
Temp Fault	<p>The inverter temperature is high.</p> <ul style="list-style-type: none"> • Please check if the environment temperature. • Wait for a while to check if back to normal. • Or seek for help from us.
Ground Fault	<p>The ground connection is failed.</p> <ul style="list-style-type: none"> • Check the voltage of neutral and PE. • Check AC wiring. • Disconnect PV, grid and battery, then reconnect. • Or seek help from us, if not go back to normal state.
Over Load Fault	<p>Over load in on grid mode.</p> <ul style="list-style-type: none"> • Please check if the load power exceeds the limit. • Or seek for help from us.
Eps Over Load	<p>Over load in off grid mode.</p> <ul style="list-style-type: none"> • Please check if the eps load power exceeds the limit. • Or seek for help from us.
Bat Power Low	<p>The battery power is low.</p> <ul style="list-style-type: none"> • Wait the battery to be recharged. • Or seek for help from us.
HW Bus Vol Fault	<p>Bus voltage out of range detected by hardware.</p> <ul style="list-style-type: none"> • Disconnect PV, grid and battery, then reconnect. • Or seek help from us, if not go back to normal state.

HW Pv Cur Fault	<p>PV input current high detected by hardware.</p> <p>Check whether PV positive and negative are connected.</p> <ul style="list-style-type: none"> • Disconnect PV, grid and battery, then reconnect. • Or seek help from us, if not go back to normal state.
HW Bat Cur Fault	<p>Battery current high detected by hardware.</p> <ul style="list-style-type: none"> • Disconnect PV, grid and battery, then reconnect. • Or seek help from us, if not go back to normal state.
SCI Fault	<p>The communication between master and manager is fail.</p> <ul style="list-style-type: none"> • Disconnect PV, grid and battery, then reconnect. • Or seek help from us, if not go back to normal state.
MDSP SPI Fault	<p>The communication between master and slave is fail.</p> <ul style="list-style-type: none"> • Disconnect PV, grid and battery, then reconnect. • Or seek help from us, if not go back to normal state.
MDSP Smpl Fault	<p>The master sample detection circuit is failed.</p> <ul style="list-style-type: none"> • Disconnect PV, grid and battery, then reconnect. • Or seek help from us, if not go back to normal state.
Res Cur HW Fault	<p>Residual current detection device is failed.</p> <ul style="list-style-type: none"> • Disconnect PV, grid and battery, then reconnect. • Or seek help from us, if not go back to normal state.
Inv EEPROM Fault	<p>The inverter eeprom is fault.</p> <ul style="list-style-type: none"> • Disconnect PV, grid and battery, then reconnect. • Or seek help from us, if not go back to normal state.
PvCon Dir Fault	<p>The PV connection is reversed.</p> <ul style="list-style-type: none"> • Check if the positive pole and negative pole of PV are correctly connected. • Or seek help from us.
Bat Relay Open	<p>The battery relay keeps open.</p> <ul style="list-style-type: none"> • Disconnect PV, grid and battery, then reconnect. • Or seek help from us, if not go back to normal state.
Bat Relay Short Circuit	<p>The battery relay keeps close.</p> <ul style="list-style-type: none"> • Disconnect PV, grid and battery, then reconnect. • Or seek help from us, if not go back to normal state.
Bat Buck Fault	<p>The battery buck circuit mosfet is fail.</p> <ul style="list-style-type: none"> • Disconnect PV, grid and battery, then reconnect. • Or seek help from us, if not go back to normal state.
Bat Boost Fault	<p>The battery boost circuit mosfet is fail or The relay on the battery side of the inverter is not closed.</p> <p>To upgrade to the latest software, at least ensure that the master is upgraded to 1.69 or above.</p> <ul style="list-style-type: none"> • Disconnect PV, grid and battery, then reconnect. • Or seek help from us, if not go back to normal state.
Eps Relay Fault	<p>The eps relay is failed.</p> <ul style="list-style-type: none"> • Disconnect PV, grid and battery, then reconnect. • Or seek help from us, if not go back to normal state.

Hybrid Series Storage Inverter

BatCon Dir Fault	<p>The battery connection is reversed.</p> <ul style="list-style-type: none"> • Check if the positive pole and negative pole of battery are correctly connected. • Or seek help from us.
Grid Relay Fault	<p>The grid relay keeps open or close.</p> <ul style="list-style-type: none"> • Disconnect PV, grid and battery, then reconnect. • Or seek help from us, if not go back to normal state.
RDSP SPI Fault	<p>The communication between master and slave is fail.</p> <ul style="list-style-type: none"> • Disconnect PV, grid and battery, then reconnect. • Or seek help from us, if not go back to normal state.
RDSP Smpl Fault	<p>The slave sample detection circuit is failed.</p> <ul style="list-style-type: none"> • Disconnect PV, grid and battery, then reconnect. • Or seek help from us, if not go back to normal state.
ARM EEPROM Fault	<p>The manager eeprom is fault.</p> <ul style="list-style-type: none"> • Disconnect PV, grid and battery, then reconnect. • Or seek help from us, if not go back to normal state.
Meter Lost Fault	<p>The communication between meter and inverter is interrupted.</p> <ul style="list-style-type: none"> • Check if the communication cable between meter and inverter is correctly and well connected.
BMS Lost	<p>The communication between BMS and inverter is interrupted.</p> <ul style="list-style-type: none"> • Check if the communication cable between BMS and inverter is correctly and well connected.
Bms Ext Fault	<p>The communication between BMS and inverter is interrupted.</p> <ul style="list-style-type: none"> • Check if the communication cable between BMS and inverter is correctly and well connected.
Bms Int Fault	<p>DIP switch at the wrong position; The communication between battery packs is interrupted.</p> <ul style="list-style-type: none"> • Move the DIP switch to the correct position; • Check if the communication cable between battery packs is correctly and well connected.
Bms Volt High	<p>Battery over voltage.</p> <ul style="list-style-type: none"> • Please contact battery supplier.
Bms Volt Low	<p>Battery under voltage.</p> <ul style="list-style-type: none"> • Please contact battery supplier.
Bms ChgCur High	<p>Battery charge over current.</p> <ul style="list-style-type: none"> • Please contact battery supplier.
Bms DchgCur High	<p>Battery discharge over current.</p> <ul style="list-style-type: none"> • Please contact battery supplier.

Hybrid Series Storage Inverter

Bms Temp High	Battery over temperature. • Please contact battery supplier.
Bms Temp Low	Battery under temperature. • Please contact battery supplier.
BmsCellImbalance	The capacities of cells are different. • Please contact battery supplier.
Bms HW Protect	Battery hardware under protection. • Please contact battery supplier.
BmsCircuit Fault	Bms hardware circuit fault. • Please contact battery supplier.
Bms Insul Fault	Battery insulation fault. • Please contact battery supplier.
BmsVoltsSen Fault	Battery voltage sensor fault. • Please contact battery supplier.
BmsTempSen Fault	Battery temperature sensor fault. • Please contact battery supplier.
BmsCurSen Fault	Battery current sensor fault. • Please contact battery supplier.
Bms Relay Fault	Battery relay fault. • Please contact battery supplier.
Bms Type Unmatch	The capacity of battery packs is different. • Please contact battery supplier.
Bms Ver Unmatch	The software between slaves are different. • Please contact battery supplier.
Bms Mfg Unmatch	The cell manufacture is different. • Please contact battery supplier.
Bms SwHw Unmatch	The slave software and hardware are not match. • Please contact battery supplier.
Bms M&S Unmatch	The software between Master and Slave are not match. • Please contact battery supplier.
Bms ChgReq NoAck	No action for charging request. • Please contact battery supplier.

10.2 Troubleshooting and Routine Maintenance

- Troubleshooting
 - a. Please check the fault message on the System Control Panel or the fault code on the inverter information panel. If a message is displayed, record it before doing anything further.
 - b. Attempt the solution indicated in table above.
 - c. If your inverter information panel is not displaying a fault light, check the following to make sure that the current state of the installation allows for proper operation of the unit:
 - (1) Is the inverter located in a clean, dry, adequately ventilated place?
 - (2) Have the DC input breakers opened?
 - (3) Are the cables adequately sized?
 - (4) Are the input and output connections and wiring in good condition?
 - (5) Are the configurations settings correct for your particular installation?
 - (6) Are the display panel and the communications cable properly connected and undamaged?

Contact Customer Service for further assistance. Please be prepared to describe details of your system installation and provide the model and serial number of the unit.

- Maintenance checking list

During the process of using the inverter, the responsible person shall examine and maintain the machine regularly. The required actions are as follows.

- Check that if the cooling fins at the rear of the inverters are collecting dust/dirt, and the machine should be cleaned when necessary. This work should be conducted periodically.
- Check that if the indicators of the inverter are in normal state, check if the display of the inverter is normal. These checks should be performed at least every 12 months.
- Check if the input and output wires are damaged or aged. This check should be performed at least every 12 months.
- Get the inverter panels cleaned and their security checked at least every 6 months.

Note: Only qualified individuals may perform the following works.

11 Inverter Storage and Disposal

11.1 Disassembling the Inverter

- Disconnect the inverter from the DC input and AC output. Wait for 15 minutes to ensure the inverter is completely powered down.
- Disconnect communication cables and any optional monitoring modules. Remove the inverter from the wall mounting bracket.

If possible, use the original packaging to repack the inverter. If the original packaging is unavailable, an equivalent box meeting the following requirements may be used:

- Capable of bearing a weight of 30 kg.
- Includes handles.
- Can be fully enclosed

11.2 Storing the Inverter

If the inverter is not put into operation immediately, it must be stored under specific environmental conditions.

- Regularly inspect the storage condition of the inverter. Check for moisture, mold, or signs of pest/rodent infestation. Replace packaging materials promptly if necessary.
- The equipment must be stored in a dry, well-ventilated area with a relatively stable temperature, consistently maintained between -40°C ~ $+70^{\circ}\text{C}$, and a relative humidity range of 5% to 95%. Avoid direct sunlight and keep a distance of $\geq 2\text{m}$ from heat sources.
- Avoid locations subject to water splashing, rain, dampness, high temperatures, or outdoor exposure. If the floor is damp, place the packaging box on a shelf or elevated platform to avoid direct contact with the ground and minimize moisture risk.
- The storage area must be free of harmful gases, flammable, explosive materials, and corrosive chemicals.
- For long-term storage, the equipment must be covered or appropriate measures taken to protect it from contamination and environmental impact.
- Avoid mechanical shock, heavy pressure, strong electric fields, and strong magnetic fields.
- When stacking multiple inverters, do not exceed 4 cartons in height.
- Products stored under the above conditions for more than 12 months must undergo capacity verification tests and re-inspection before they can be used.

Note: Please adhere to the storage requirements. Product damage caused by failure to meet these conditions is not covered under warranty.

11.3 Transporting the Inverter

- Ensure the product is securely packaged before vehicle transport. Use enclosed containers for long-distance transportation.
- It is strictly prohibited to transport this product together with equipment or items that could potentially affect or damage it.

11.4 Decommissioning/Scrapping the Inverter

- Certain components of the inverter may cause environmental pollution. When disposing of the inverter or its related components, ensure compliance with local waste disposal regulations.

12Appendix

12.1 Quality Guarantee

FOXESS Co., Ltd. (hereinafter referred to as "the Company") will, for products found to be faulty during the warranty period, repair the product free of charge or replace it with a new one.

Supporting Documentation Required

When requesting warranty service, the customer must present the original purchase invoice indicating the date of purchase. Furthermore, the product's trademark must be clearly visible. The Company reserves the right to decline warranty coverage if these conditions are not met.

Relevant Conditions

- Non-conforming products replaced under warranty shall be disposed of by the Company.
- The customer must allow the Company a reasonable period of time to complete repairs on faulty equipment.

Warranty Exclusions

The Company reserves the right to decline warranty coverage under the following circumstances:

- The entire machine or specific components have exceeded the free warranty period.
- Damage incurred during transportation.
- Faults resulting from incorrect installation, modification, or use.
- Operation in environments that exceed the limits specified as harsh in this manual.
- Malfunctions or damage caused by installation, repair, alteration, or disassembly performed by service organizations or personnel not authorized by the Company.
- Use or installation outside the scope defined in the relevant international standards.
- Damage caused by abnormal natural disasters.
- Damage resulting from storage conditions that do not meet the requirements stated in the product documentation.
- Any losses arising from failure to adhere to the safety precautions outlined in this manual.

If a product failure is caused by any of the above circumstances and the customer still requests repair services, the Company's authorized service organization may, upon assessment, provide repair services subject to a charge.

Other Provisions

The Company reserves the right to change product dimensions and parameters based on its latest documentation without prior notice.

12.2 Contact Us

If you have any questions about the product, please contact us:

- Fox ESS Headquarters: No.939, Jinhai Third Road, New Airport Industry Area, Longwan District, Wenzhou, Zhejiang, China.
- Wuxi R&D Center: No. 97 Huaqing Avenue, Wuxi Economic Development Zone (Intersection of Huaqing Avenue and Huayun Road)
- Wuhan R&D Center: No.5, Jiayuan Road, Hongshan District, Wuhan, Hubei, China
- Shanghai R&D Center: No.1255, Jinhai Road, Pudong New Area, Shanghai, China
- After-Sales Service Hotline: 400 1888 900
- Contact Telephone (Wenzhou): 0577-88159999
- Contact Telephone (Wuxi): 0510-68092998
- Contact Us: info@fox-esscom
- Contact Us (EV Charger): ev@fox-esscom
- After-Sales Service: service@fox-esscom