

OPEN SIDE SERIES

CASSETTE NORDIC W90

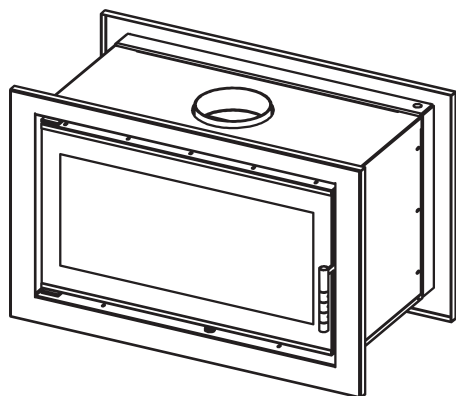

TECHNICAL SPECIFICATION

| | |
|-----------------------|--------------------------|
| MODEL | CASSETTE NORDIC W 90 |
| POWER | 5 - 10 KW |
| EFFICIENCY | >80% |
| CONSUME | 2 - 3.5 KG/H |
| WOOD LENGTH | MAX.25 CM |
| WEIGHT | 146 KG |
| FLUE GAS TEMPERATURE | 242 °C |
| FUEL | WOOD/BRIQUETTE |
| PIPE DIAMETER | Φ 150 MM |
| CO | <1 250 MG/M ³ |
| FRESH AIR INLET | Φ 150 MM |
| PRIMARY/SECONDARY AIR | |
| VENTILATION SYSTEM | ON ORDER |
| WARRANTY | 5 YEARS |



OVERALL DIMENSION

| | |
|--------|--------|
| HEIGHT | 622 MM |
| DEPTH | 414 MM |
| WIDTH | 998 MM |

