



**CORE
MACHINERY**

CM-20S COMPACT EXCAVATOR

2.0 TONNE MINI EXCAVATOR

CM-20S compact excavator gives you the performance and efficiency you need in tight spaces.

SPECIFICATIONS

Bucket Capacity	0.006 m ³
Swing Speed	10 - 12 rmp
Gradeability	35°
Max. Bucket Digging Force	14 KN
Max. Arm Digging Force	10 KN
Engine Model	3TE25
Power / Revolution Speed	18.4 KW / 2350 rmp
System Pressure	18 MPa

MACHINE SIZE

Length*Width*Height	3655 x 1050 x 2232 mm
Cabin Height	2232 mm
Sproket to Idler	1231 mm
Wheel (Track) Gauge	820 mm
Minimum Ground Clearance	210 mm
Tail Swing Radius	1000 mm

Due to technological upgrades, the actual product may be different from what is shown. Diagrams, photos and information are for reference only.



CM-20C

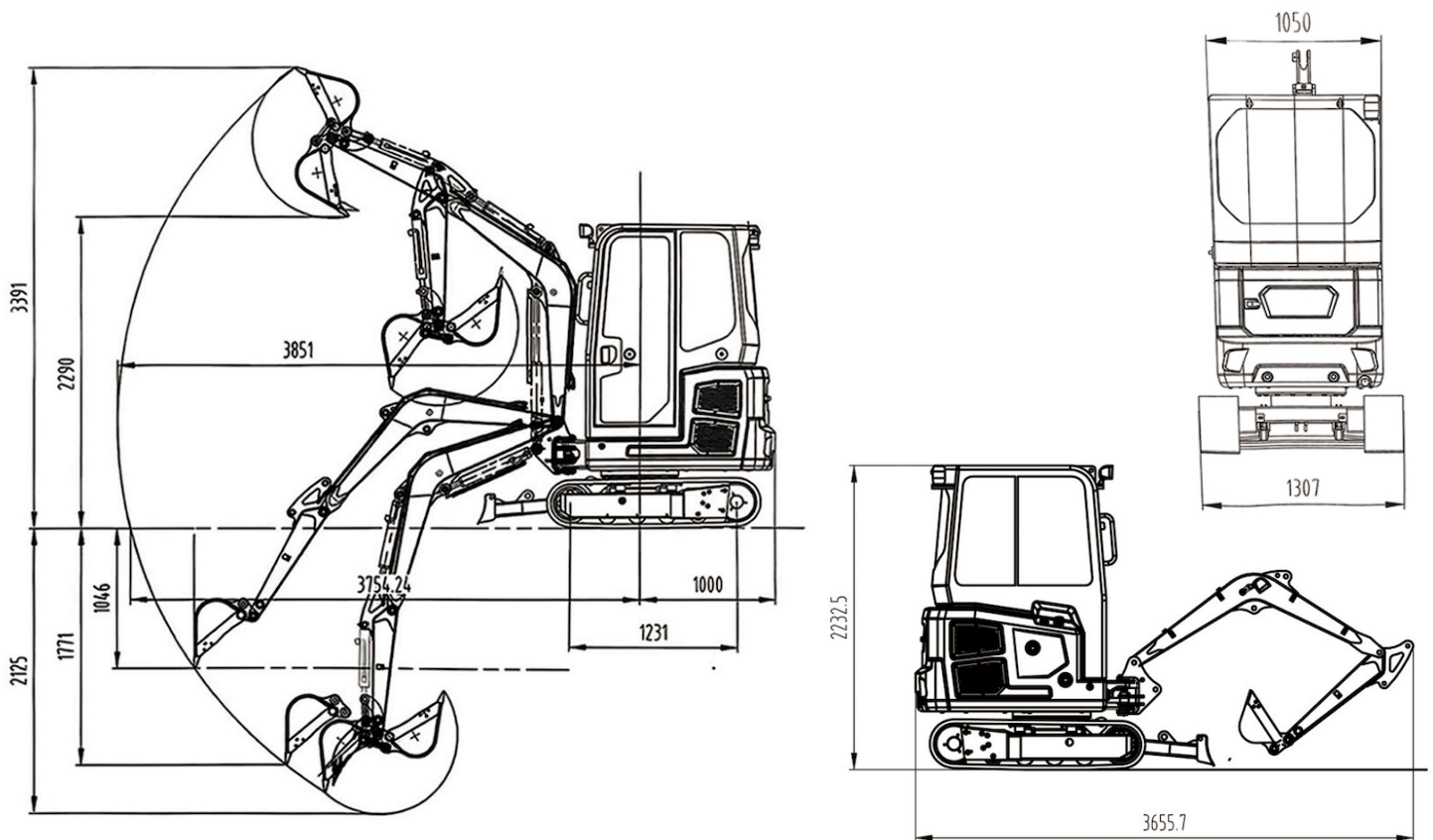

WORKING RANGE

Max. Digging Height	3391 mm
Max. Dumping Height	2290 mm
Max. Digging Depth	2125 mm
Max. Vertical Digging Depth	1771 mm
Max Digging Radius	3851 mm
Min. Swing Radius	1701 mm
Max. Dozer Blade Lifting Distance	230 mm
Max. Dozer Blade Cutting Distance	275 mm
Boom Swing Angle (Left)	75°
Boom Swing Angle (Right)	45°

Due to technological upgrades, the actual product may be different from what is shown. Diagrams, photos and information are for reference only.