



# ID Speed Gate 5800

**Date: March 2025**

**Version: ID Speed Gate 5800**



Please read and follow the installation instructions before operating the appliance and keep the instructions for future reference or use after troubleshooting.

## Inhalt

<b>1. Product Instruction .....</b>	<b>3</b>
<b>1.1 Note.....</b>	<b>3</b>
<b>2. Product Structure and Working Principle .....</b>	<b>3</b>
<b>2.1 Electronic Control System of Turnstile Gate .....</b>	<b>3</b>
<b>2.2 System Operating Principle.....</b>	<b>4</b>
<b>3. Install Instruction .....</b>	<b>5</b>
<b>3.1 Installation Note &amp; Suggestion .....</b>	<b>5</b>
<b>3.2 Turnstile Circuit Board Wiring Diagram .....</b>	<b>6</b>
<b>4. Optical Turnstile Circuit Board Description.....</b>	<b>9</b>
<b>4.1 Adjustment of Gate Position in Swing Turnstile / Speed Gate Mode .....</b>	<b>9</b>
<b>4.2 Adjustment of Gate Position in Flap Turnstile Mode .....</b>	<b>9</b>
<b>4.3 Parameter Settings .....</b>	<b>9</b>
<b>5. Product Maintenance .....</b>	<b>13</b>
<b>5.1 Daily Maintenance .....</b>	<b>13</b>
<b>5.2 Tips and Troubleshooting .....</b>	<b>13</b>
<b>6. Support.....</b>	<b>14</b>

## 1. Product Instruction

### 1.1 Note

- 1) Before installation, operation or maintenance, turn off power.
- 2) Do not change the inside wiring, take a photo before any disconnection.
- 3) Do not use the turnstile inside power supply to connect other third-party device.
- 4) Do not operate when thundering and lightning, in case damage the turnstile electrical parts.

## 2. Product Structure and Working Principle

### 2.1 Electronic Control System of Turnstile Gate

The electronic control system consists of card reader, circuit board, infrared sensor, direction indicator board, alarm, transformer, etc.

**Card reader (self-provided):**

After reading the information on the card and judging and processing, send the application pass signal (switch signal) to the master board.

**Master board:**

The control center of the system, which receives signals from the card reader and infrared sensor, makes logical judgment and processing of these signals, and then issues execution commands to the direction indicator, motor, counter and alarm.

**Infrared sensor:**

Detect the pedestrian position and safe protection.

**Direction indicator light:**

Displays the current status of the gate and guides pedestrians to pass through the gate in a safe and orderly passage.

**Alarm:**

When the system detects pedestrians entering the passage illegally, the gate will alarm.

Item NO.	NAME	Function
1	Access control system	IC/ID card access control, fingerprint machine, face recognition, QR code device, gate opening signal on the circuit board of gate machine, remote control, button to open the gate(optional)
2	Circuit board (master and slave board)	The control center of the system, which receives signals from the card reader and infrared sensor, and makes logical judgment and processing of these signals, and then sends out execution commands to the direction indicator, motor, counter and alarm.
3	Infrared sensor	Detect the position of pedestrians and safety protection
4	Direction indicator	Display the current traffic sign status of the gate and guide pedestrians through the gate
5	Alarm (speaker)	When the system detects a pedestrian illegally entering the passageway, it will alarm.
6	Motor	Drive the mechanism
7	Power supply	Power supply for all the electronic control system

## 2.2 System Operating Principle

- a) Power on, the system enters working state after 3 seconds.
- b) When the card reader reads a valid card, the turnstile gate emits a pleasant sound, indicating successful card reading to pedestrians. At the same time, the information read is processed and judged, and an access request signal is sent to the master Board.
- c) The master control board receives signals from the card reader and the infrared sensor, comprehensively processes them, and sends effective control signals to the direction indicator and the motor, causing the direction indicator to display a green arrow for passage. At the same time, the turnstile gate emits a set voice prompt, the master control board controls the motor operation, the gate opens, allowing pedestrians to pass.
- d) When pedestrians pass through the gate according to the direction indicator, the infrared sensor senses the entire process of pedestrian passage through the gate and continuously sends signals to the master board until the pedestrian completely passes through the gate.
- e) If a pedestrian forgets to read the card or uses an invalid card to entry, the system prohibits pedestrian passage, emits a voice alarm, and continues to alarm until the pedestrian exits and the alarm is resolved. A valid card must be swiped for passage.

## 3. Install Instruction

### 3.1 Installation Note & Suggestion

**Note:** During installation and construction, relevant circuits should be disconnected to ensure that all circuits are correct before energizing.

#### ►► Installation Suggestion:

- 1) For cables, suggest laid 60mm deep, over 50mm, and connector area be bending to avoid water.
- 2) If the turnstiles install in the outside, suggest installed in concrete deep 100-200mm to avoid natural damaged.
- 3) All the operation should be done when power off.
- 4) Wear the strong electric cable and the weak electric cable are respectively with 3/4 "PVC pipe and buried to the corresponding position with cement.
- 5) After adjusting the foundation surface, arrange the equipment in good order.
- 6) After the hole location is determined, drill the hole and embed the anchor bolt or expansion bolt of M12.
- 7) Open the case, select one of the equipment as the reference (preferably choose the middle one as the reference), align the base bolt hole with the corresponding anchor bolt, and pre-tighten the nut.
- 8) Connect the power line and control line according to the wiring diagram, and connect the system protection ground wire.
- 9) Check the mains wiring according to the wiring diagram, check the power wiring and other wiring of the whole equipment are correct, and the power can be adjusted after confirmation.
- 10) After completion of the installation, check the connection condition of earth wire, connector assembly for connecting line and all moving parts with the device. Make sure the connection is firm in order to prevent failure caused by long time operation. If any screw or part is not tightened, please tighten.
- 11) After the equipment status check is normal, the following functions can be debugged.

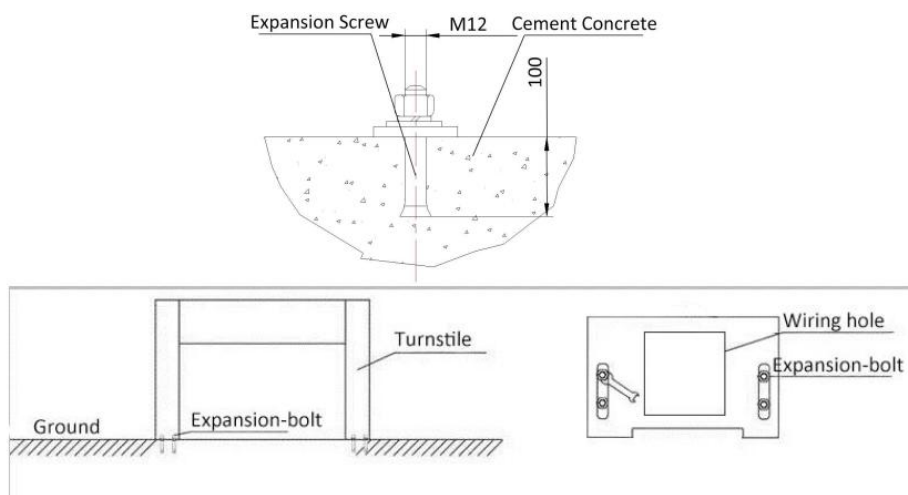

\*Note: The above image shows how to install the expansion screws. For the bottom hole diagram of each model, need to find the corresponding model.

### **3.2 Turnstile Circuit Board Wiring Diagram**

\*Turnstile electrical parts area with power supply port, please connect to 110V/220V electrical power supply. \*Turnstile circuit board with port "OP-L", "COM", "OP-R", it can be connected to any type of the third-party access controller device.



# Optical Turnstile Gate Circuit Board Wiring Diagram

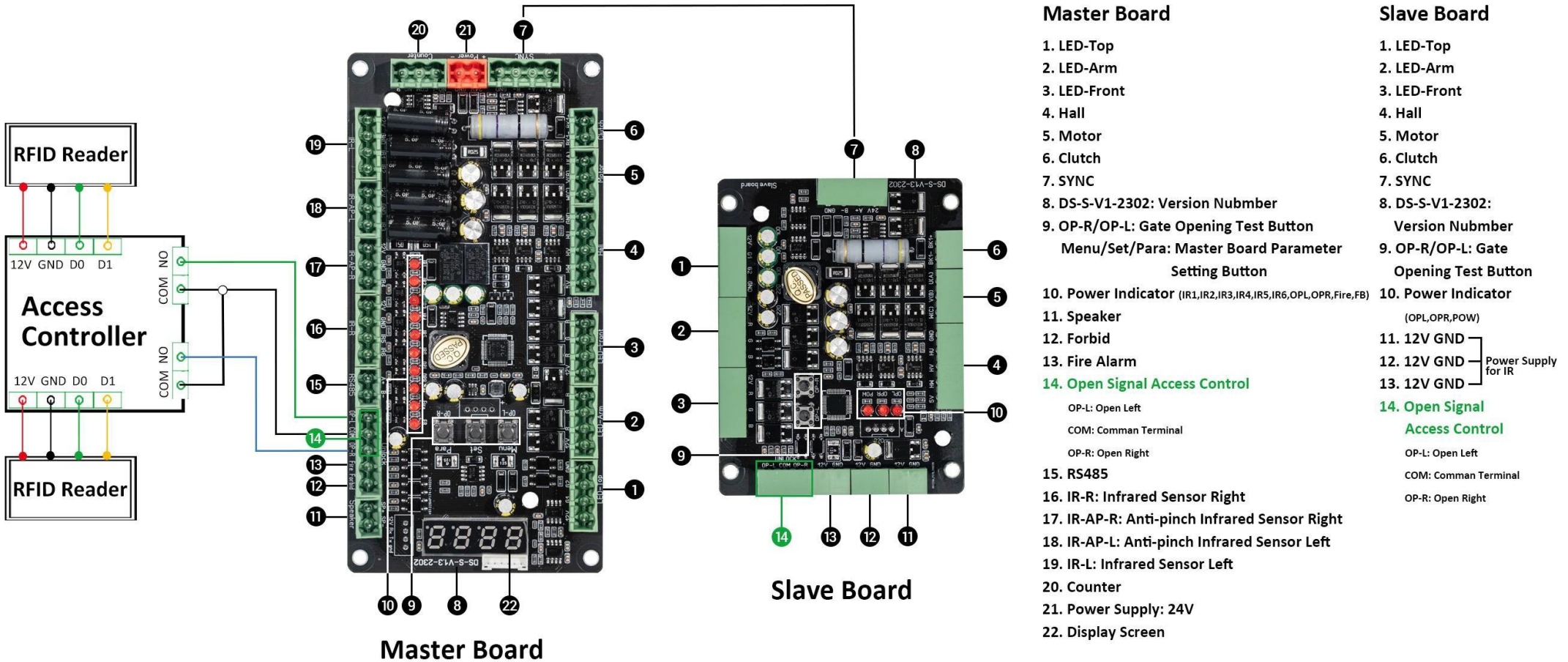

## 4. Optical Turnstile Circuit Board Description

### 4.1 Adjustment of Gate Position in Swing Turnstile / Speed Gate Mode

1. Press the SET (middle button) 5 times consecutively. The system will prompt "Please manually adjust the wing door position" and enter the wing door (gate) adjustment mode.
2. Move the gate to the target position and stop. Hold it in place for 3 seconds without moving. A beep sound or corresponding light flash will indicate that the current position has been sampled. • The system will automatically determine whether the current position is the left limit, right limit, or limit position based on the gate's location.
3. Finally, align the gate back to the middle and hold it still for about 10 seconds. The system will prompt "Set up complete, welcome to use" and exit the adjustment mode. • In most cases, the system will automatically obtain the appropriate left and right positions. The user only needs to adjust the limit position, align the wing door, and wait for the system to automatically exit.

### 4.2 Adjustment of Gate Position in Flap Turnstile Mode

1. Press the SET (middle button) five times consecutively. The system will prompt "Please manually adjust the wing door position" and enter the wing door (gate) adjustment mode.
2. The "Left Open" and "Right Open" buttons on the master board control the master motor's reciprocating motion, while the same buttons on the slave board control the slave motor's reciprocating motion. Use the buttons to move the gate to the target position and stop. Hold it in place for 3 seconds without moving. A beep sound or corresponding light flash will indicate that the current position has been sampled.
  - The system will automatically determine whether the current position is the left limit or right limit based on the gate's location.
3. Press and hold the middle button for more than 2 seconds to exit the adjustment mode.

### 4.3 Parameter Settings

#### Entering Parameter Setting:

- Press and hold the SET (middle button) until the digital display flashes to enter the parameter setting mode.
- The first two digits of the digital display show the menu, while the third and fourth digits show the value. Use the Left Open button to set the menu and the Right Open button to set the value.
- Press and hold the SET button for about 2 seconds to save the menu value successfully.

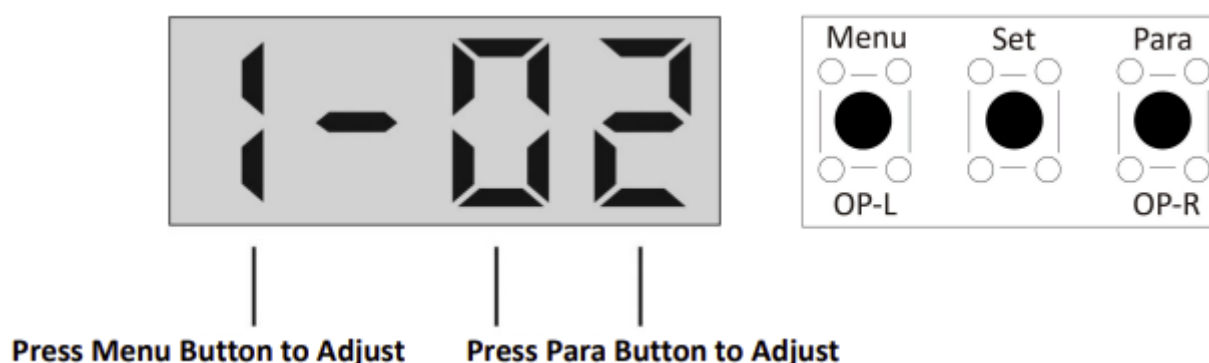

As shown in the above diagram, the current menu is "Gate Opening Mode", and parameter 02 represents "Left Infrared Free Passage".

### Menu and Functions:

0	<b>Machine Number (Range: 1~99, Default: 1):</b> The 485 communication machine number.
1	<b>Gate Opening Mode (Range: 1~4, Default: 1):</b> 1: Standard mode. 2: Left infrared free passage. 3: Right infrared free passage. 4: Left and right infrared free passage. When adjusting, the top light panel will move accordingly, and the infrared free passage direction can be referenced according to the direction of the directions of the arrows.
2	<b>Gate Opening Wait Time (Range: 1~90, Default: 8):</b> Time in seconds. For values below 20, press once to increase by 1. For values above 20, press once to increase by 10.
3	<b>Left Gate Opening Voice (Range: 0~9, Default: 3):</b> 0: Thank you 1: Come in please 2: See you 3: Welcome 4: Goodbye 5: Have a nice day 6: Have a nice trip 7: Please put your safety helmet 8: Verify success 9: Mute
4	<b>Right Gate Opening Voice (Range: 0~9, Default: 5):</b> Voice settings same as left gate opening voice.
5	<b>Voice Volume (Range: 1~15, Default: 12):</b> The higher the value, the louder the volume.
6	<b>Master Motor Speed (Range: 1~25, Default: 10):</b> Adjust based on actual conditions to avoid speed overload.
7	<b>Slave Motor Speed (Range: 1~25, Default: 10):</b> Same as the master motor speed.
8	<b>Debugging Mode (Range: 0~2, Default: 0):</b> 0: Normal mode. 1: Automatic aging mode. 2: Restore factory settings (Requires a restart to take effect)
9	<b>Deceleration Range (Range: 1~20, Default: 10):</b> The larger the value, the longer the deceleration distance. Adjust accordingly based on the smoothness of gate movement.
10	<b>Self-test Speed (Range: 1~9, Default: 3):</b> The higher the value, the faster the self-test speed.

11	<p><b>Passage Mode (Range: 0~2, Default: 0):</b></p> <p>0: Smooth passage mode, gate closes with 1-second delay when detecting an electric scooter.</p> <p>1: Memory mode, multiple cards for multiple people.</p> <p>2: One card per person mode, without electric scooter detection function</p>
12	<p><b>Gate Closing Control (Range: 0~9, Default: 2):</b></p> <p>0: Close after people pass through the middle infrared. (for flap turnstile)</p> <p>1: Close after people triggers the last infrared. (for flap turnstile)</p> <p>2: Close after people pass through the last infrared.</p> <p>3~9: Delay closing by (Value-2) seconds after passing the last infrared.</p>
13	<p><b>Single Motor Mode (Range: 0~1, Default: 0):</b></p> <p>0: Dual motor mode. (Dual door gate)</p> <p>1: Single motor mode. (Standalone single door gate)</p>
14	<p><b>Language Selection (Range: 0~6, Default: 0):</b></p> <p>0: Chinese</p> <p>1: English</p> <p>2: French</p> <p>3: Spanish</p> <p>4: Russian</p> <p>5: Swedish</p> <p>6: Arabic</p>
15	<p><b>Encountering obstruction, the infrared anti-pinch rebound. (Range: 0~1, Default: 1):</b></p> <p>0: No rebound on obstruction.</p> <p>1: Rebound on obstruction.</p>
16	<p><b>Mechanical Anti-pinch Sensitivity (Range: 1~9, Default: 5):</b></p> <p>The higher the value, the more sensitive.</p>
17	<p><b>Reverse Entry Handling (Range: 0~1, Default: 1):</b></p> <p>0: Reverse triggering without gate closing, only alarm.</p> <p>1: Reverse triggering with gate closing, pass invalid and the gate will not open again.</p>
18	<p><b>Turnstile Type (Range: 0~3, Default: 0):</b></p> <p>0: Standard swing gate, speed gate</p> <p>1: Cylindrical swing gate.</p> <p>2: Flap gate.</p> <p>3: Single-direction swing gate mod</p>
19	<p><b>Emergency Gate Opening Direction (Range: 0~2, Default: 2):</b></p> <p>0: Open to the left in case of power off.</p> <p>1: Open to the right in case of power off.</p> <p>2: The system will choose the direction automatically based on the current situation.</p>
20	<p><b>Motor Resistance (Range: 1~9, Default: 5):</b></p> <p>The larger the value, the greater the resistance. Excessive resistance may cause power restart, it's recommended to use the default value for 6.25A power supply.</p>
21	<p><b>Voice alarm for illegal intrusion (Range: 0~1, Default: 1):</b></p> <p>0: Close all alarm voices.</p> <p>1: Prompt "Please do not break in" when illegal entry.</p>
22	<p><b>Effective Signal Delay for Left and Right Infrared (Range: 1~9, Default: 5):</b></p> <p>Time = parameter * 20 milliseconds (default 100ms).</p>

23	<p><b>Motor Running Direction (Range: 1~4, Default: 1):</b></p> <p>1: Master motor forward, slave motor reverse;  2: Master motor reverse, slave motor forward;  3: Both master and slave motors forward;  4: Both master and slave motors reverse.</p>
24	<p><b>Clutch Lock Function (Range: 0~3, Default: 0):</b></p> <p>0: Auto-detect presence of clutch;  1: No clutch mode;  2: Clutch mode;  3: Clutch locked mode.</p>
25	<p><b>Motor Hall Type (Range: 0~4, Default: 0):</b></p> <p>0: Auto-detect;  1: Master motor +120°, slave motor +120°;  2: Master motor -120°, slave motor -120°;  3: Master motor +120°, slave motor -120°;  4: Master motor +120°, slave motor - 120°</p>
26	<p><b>Input Signal Filtering (Range: 1~9, Default: 3):</b></p> <p>Value * 10ms (default 30ms).</p>
27	<p><b>Card Swipe Allowed / Not Allowed Inside Passage (Range: 0~1, Default: 0):</b></p> <p>0: Allowed to swipe card inside the passage;  1: Not allowed to swipe card inside the passage.</p>
28	<p><b>Limit Position Deviation Alarm Threshold (Range: 1~9, Default: 3):</b></p> <p>The larger the value, the greater the allowed deviation.</p>
29	<p><b>Anti-pinch Infrared Free Passage Switch (Range: 0~1, Default: 1):</b></p> <p>0: Anti-pinch infrared does not trigger gate opening in free passage mode.  1: Anti-pinch infrared triggers gate opening in free passage mode for quick passage.</p>
30	<p><b>Free Passage Memory Function Switch (Range: 0~1, Default: 0):</b></p> <p>0: No memory function in free passage mode, only one person can pass through after multiple infrared triggers.  1: Memory function in free passage mode, multiple number of infrared triggers allows multiple people to pass.</p>
31	<p><b>Master Motor Sliding Compensation (Range: 0~9, Default: 0):</b></p> <p>Increase sliding compensation if the gate does not return to limit position immediately after opening.</p>
32	<p><b>Slave Motor Sliding Compensation (Range: 0~9, Default: 0):</b></p> <p>Increase sliding compensation if the gate does not return to limit position immediately after opening.</p>
33	<p><b>Infrared Logic Mode (Range: 0~1, Default: 0):</b></p> <p>0: 4-group infrared logic mode, either A or B signal from left or right infrared is valid.  1: 6-group infrared logic mode, both A and B signals from left or right infrared are required.</p>
34	<p><b>Master Board Front Panel Light Strip (Range: 1~4, Default: 1):</b></p> <p>1: Linked with left open, blue light for power on, green for left open, red for right open;  2: Linked with right open, blue light for power on, red for left open, green for right open;</p>

	3: Constantly on green light, 4: Constantly on red light *The working principle of diagonal and swipe card on the right side
35	<b>Slave Board Front Panel Light Strip (Range: 1~4, Default: 2):</b> Same as master board front panel light strip mode.
36	<b>Serial Communication Active Push (Range: 0~1, Default: 1):</b> 0: Passive query; 1: Active push of events such as passage, faults, and alarms.
37	<b>Serial Communication Heartbeat Push (Range: 0~1, Default: 0):</b> 0: Heartbeat push off; 1: Heartbeat push on (default every 5 seconds/times). Note: Heartbeat push function requires the active push mode in setting 37 to be enabled.

## Troubleshooting and Resolution

Digital Display	Troubleshooting	Reasons and Solutions
E010	Unable to detect master motor	Hall line or motor line connected incorrectly, motor Hall fault
E020	Unable to detect slave motor	Hall line or motor line connected incorrectly, motor Hall fault
E050	Abnormal self-test process	Hall line or motor line sequence connected incorrectly, motor fault, movement slipping or jamming
E090	Insufficient voltage	Check power input

## 5. Product Maintenance

### 5.1 Daily Maintenance

- To avoid the risk of electric shock, always ensure the power off before inspecting.
- Suggest inspected at regular time, to ensure all parts in good working.
- The material made by stainless steel, do not use hard material to clean it.
- Fingerprints or stubborn stains cleaning way: scrub by soap water or alcohol, sponge rinse with clean water, wipe dry as necessary.

### 5.2 Tips and Troubleshooting

1. After swiping card, if the gate do not open, please recheck whether all the wire well connected.
2. If indicator doesn't work, or indicate wrong direction, please exchange the inside wires to test.
3. Turnstile will automatically open after power off; if it did not, it caused by the storage battery power not enough. Make sure the storage batter with enough power.
4. The arm did not work together, check if the sync wires connect well.
5. The arms open but fail to close, check infrared sensor if it matched well.

**6. Support**

**iDTRONIC**  
**Ludwig-Reichling-Straße 4**  
**67059 Ludwigshafen am Rhein**  
**helpdesk@idtronic.de**