

ID Gate 1900

Date: June 2026

Version: ID Gate 1900

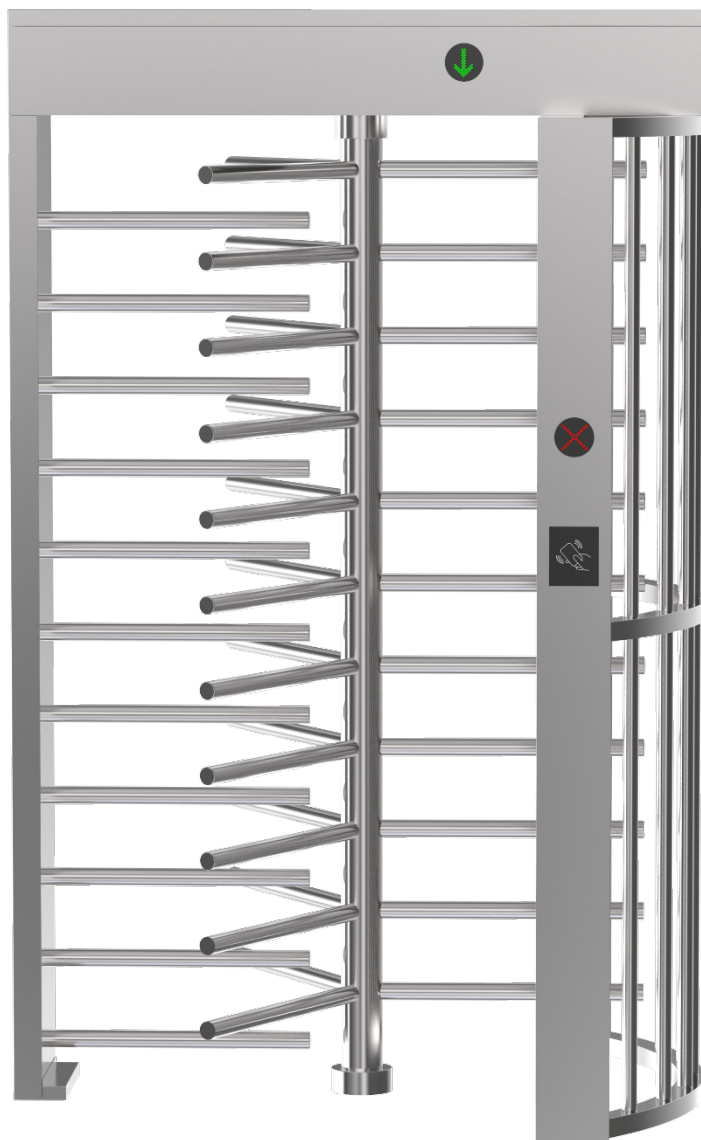

Please read and follow the installation instructions before operating the device.
Keep this manual for future reference and for troubleshooting purposes.

Table of Contents

1. Turnstile Introduction	3-4
1.1 Tripod Turnstile Details Parts	3
1.2 Turnstile Power Supply.....	3
1.3 Note.	4
2. Turnstile Electric Control System.....	4
2.1 Turnstile Electric Control System.....	4
3. Install Instruction.	5-7
3.1 Installation Note & Suggestion.	5
3.2 Turnstile Circuit Board Wiring Diagram.....	6-7
4. Tripod Turnstile & Full-Height Turnstile Circuit Board User Manual.....	8-9
4.1 Buttons for Menu Settings.....	8
4.2 Menu Parameter Descriptions (F01-F13)	8-9
5. Product Maintenance.	10
5.1 Daily Maintenance.....	10
5.2 Tips and Troubleshooting.....	10

1. Turnstile Introduction

1.1 Tripod Turnstile Details Parts

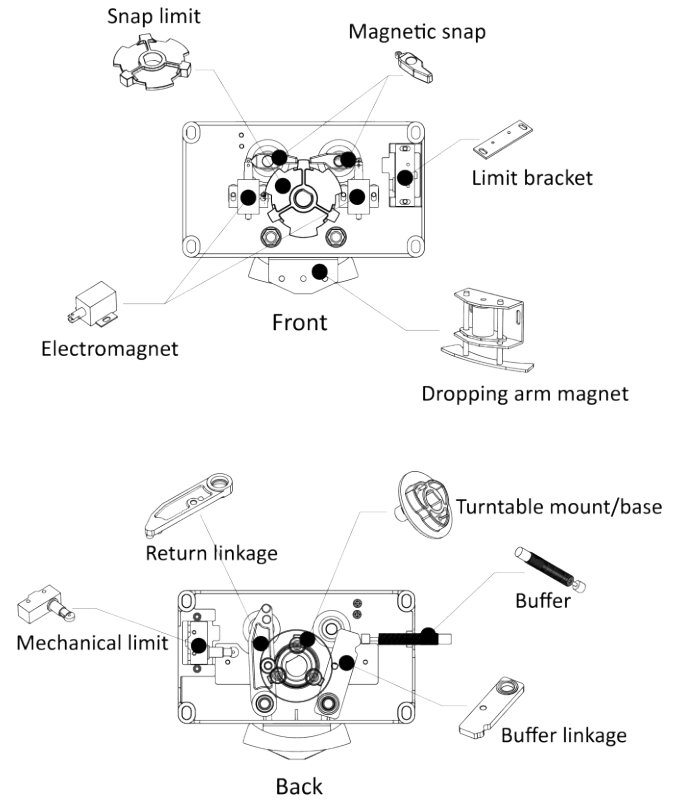
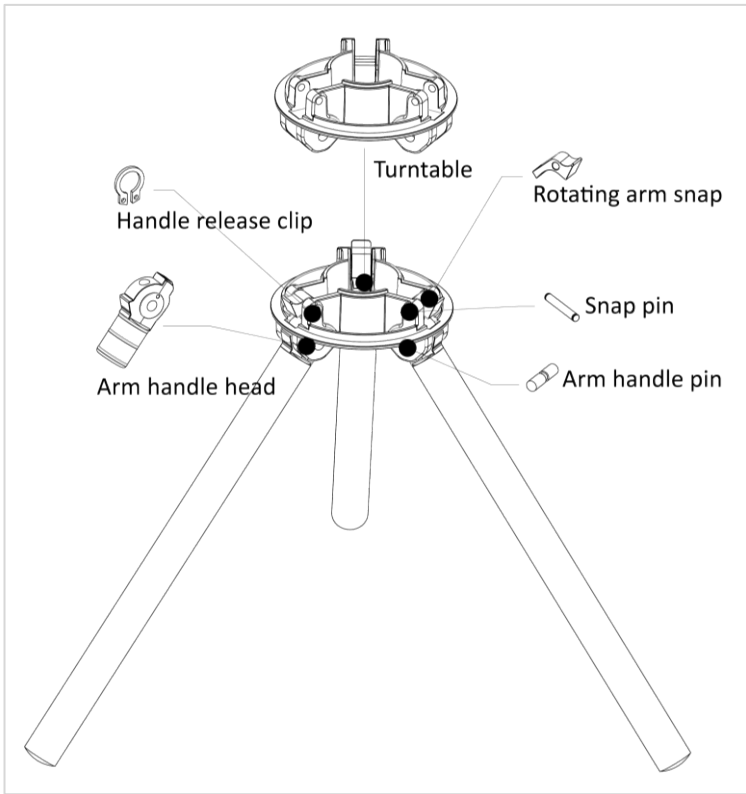

1.2 Turnstile Power Supply

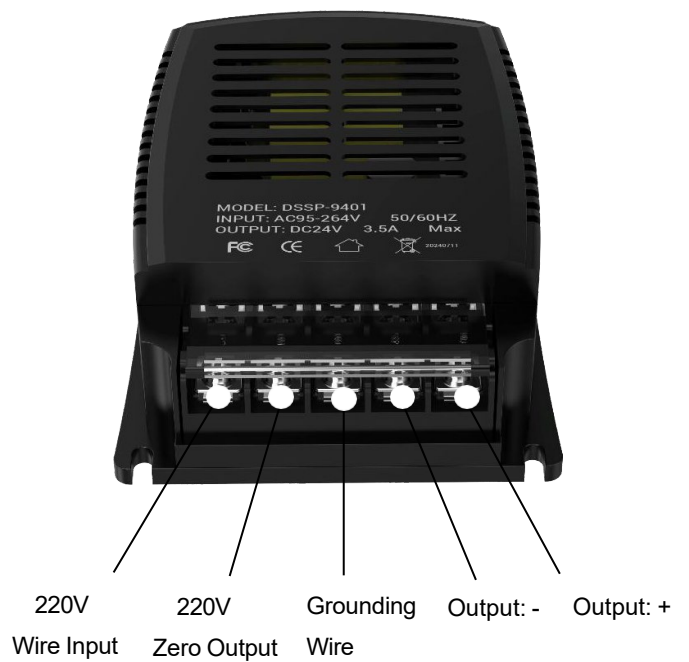
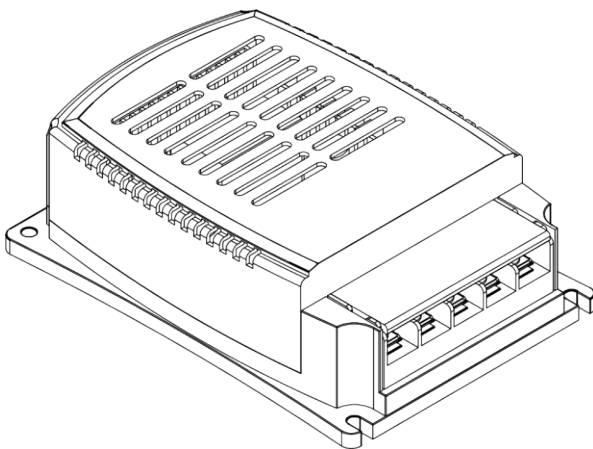

1.3 Note

- 1) Before installation, operation or maintenance, turn off the power.
- 2) Do not change the internal wiring. Take a photo before disconnecting any wires.
- 3) Do not use the turnstile's internal power supply to power any third-party devices.
- 4) Do not operate the turnstile during thunderstorms, as this may damage the electrical components.

2. Tripod Turnstile Electric Control System

2.1 Tripod Turnstile Electric Control System

The electronic control system consists of a card reader, a circuit board, a direction indicator board, a transformer, and other components.

- Card reader (provided separately): After reading and processing the card information, the card reader sends an access request signal (switch signal) to the circuit control board.
- Circuit control board: The control center of the system. It receives signals from the card reader, processes them logically, and sends execution commands to the direction indicator light, motor, counter, and alarm.
- Direction indicator light: Displays the current passage status and guides pedestrians through the passage safely and orderly.

Item NO.	NAME	FUNCTION
1	Access control system	Supports IC/ID card access control, fingerprint readers, face recognition devices, QR code devices, gate-opening signals from the turnstile control board, remote controls, and optional gate-opening buttons.
2	Circuit board	The control center of the system. It receives signals from the card reader and infrared sensor, processes them logically, and sends execution commands to the direction indicator, motor, counter, and alarm.
3	Direction indicator	The direction indicator light shows the current passage status and guides pedestrians through the passage.
4	Limit switch	Checks the opening and closing positions.
5	Power Supply	Supplies power to the circuit board.

3. Install Instruction

3.1 Installation Note & Suggestion

Note: During installation, disconnect the relevant circuits. Ensure that all wiring is correct before switching on the power.

►► **Installation Suggestion:**

- 1) Cables should be laid at least 60 mm deep. The connector area should be bent or protected to prevent water ingress.
- 2) If the turnstiles are installed outdoors, they should be fixed in a concrete foundation 100–200 mm deep to prevent environmental damage.
- 3) All work must be carried out with the power switched off..
- 4) Route the high-voltage cable and low-voltage cable separately through 3/4-inch PVC pipes and bury them in cement at the corresponding positions.
- 5) After leveling the foundation surface, position the equipment in the correct order.
- 6) After marking the hole locations, drill the holes and insert M12 anchor bolts or expansion bolts.
- 7) Open the housing. Select one unit as the reference unit, preferably the middle unit. Align the base bolt holes with the corresponding anchor bolts and pre-tighten the nuts.
- 8) Connect the power cable and control cable according to the wiring diagram, and connect the protective earth wire.
- 9) Check the mains wiring, power wiring, and all other wiring according to the wiring diagram. After confirming that all wiring is correct, the power can be switched on and adjusted.
- 10) After installation, check the earth wire, cable connector assemblies, and all moving parts of the device. Ensure that all connections are secure to prevent failures caused by long-term operation. Tighten any loose screws or parts.
- 11) After confirming that the equipment status is normal, proceed with function debugging.

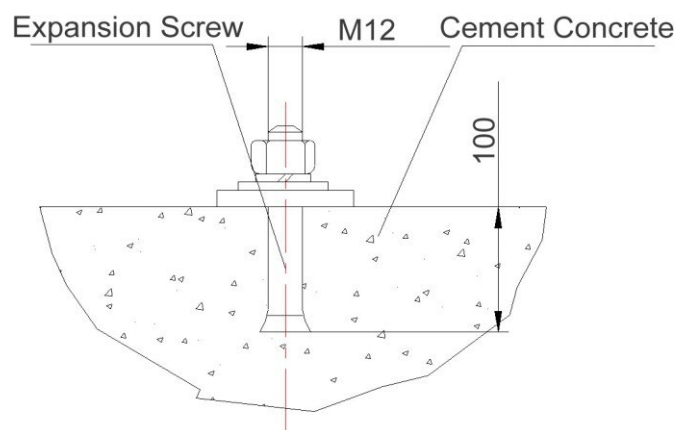

3.2 Turnstile Circuit Board Wiring Diagram

* The turnstile electrical components area includes a power supply port. Connect it to a 110 V/220 V power supply.

* The turnstile circuit board includes the ports "OP-L", "COM", and "OP-R". These ports can be connected to third-party access control devices.

Turnstile Gate Circuit Board Wiring Diagram

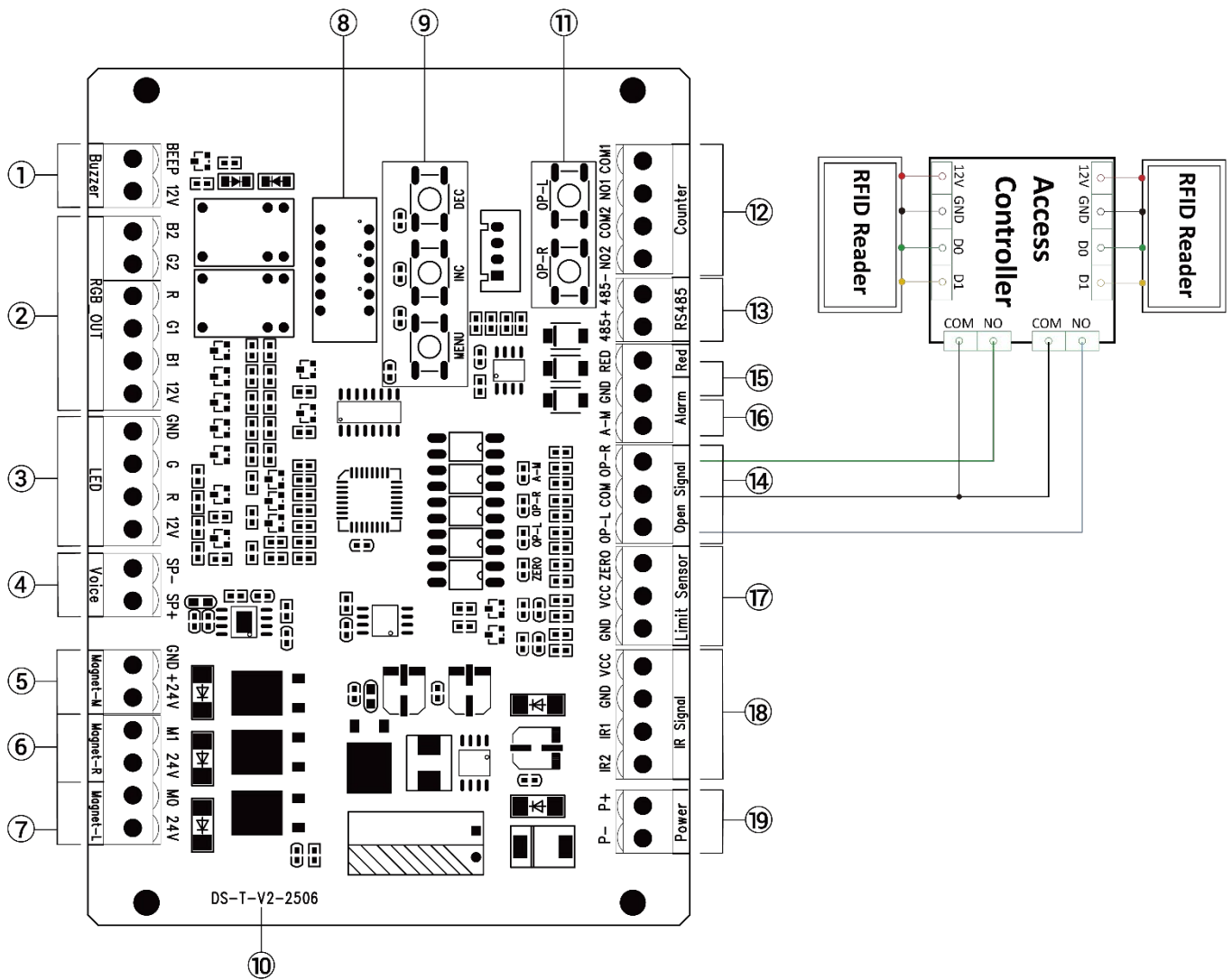

- | | |
|--|--|
| <ul style="list-style-type: none"> 1. Buzzer 2. RGB: RGB 3-Color Light 3. LED: Green and Red Led 4. Voice 5. Magnet-M: Magnet Middle 6. Magnet-R: Magnet Right 7. Magnet-L: Magnet Left 8. Display Screen 9. MENU/INC/DEC: Master Board
Parameter Setting Button 10. DS-T-V2-2506: Version Number 11. OP-R/OP-L: Gate Opening Test Button | <ul style="list-style-type: none"> 12. Counter 13. RS485 14. Open Signal Access Control
OP-L: Open Left
COM: Common Terminal
OP-R: Open Right 15. Red+GND: ① Invalid Card Shows Red Light
② Forbid: Gate Access Prohibited 16. Alarm+GND: Fire Alarm Function 17. Limit Sensor 18. IR Signal: Infrared Sensor Optional 19. Power Supply: 24V |
|--|--|

Turnstile Gate Circuit Board Wiring Diagram

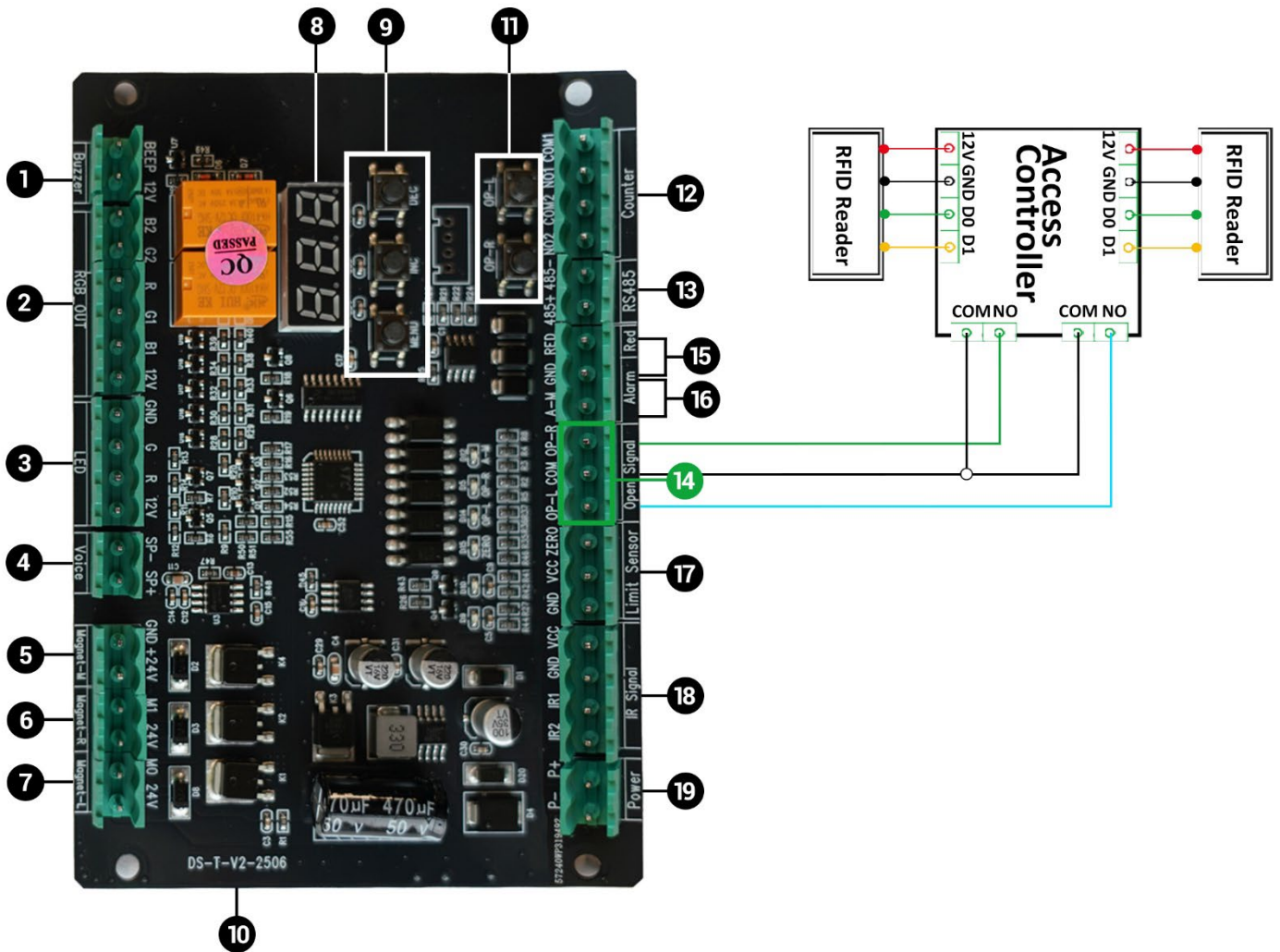

- | | |
|--|--|
| <ul style="list-style-type: none"> 1. Buzzer 2. RGB: RGB 3-Color Light 3. LED: Green and Red Led 4. Voice: Speaker 5. Magnet-M: Magnet Middle 6. Magnet-R: Magnet Right 7. Magnet-L: Magnet Left 8. Display Screen 9. MENU/INC/DEC: Master Board
Parameter Setting Button 10. DS-T-V2-2506: Version Number 11. OP-R/OP-L: Gate Opening Test Buttonn | <ul style="list-style-type: none"> 12. Counter 13. RS485 14. Open Signal Access Control
OP-L: Open Left
COM: Common Terminal
OP-R: Open Right 15. Red+GND: ①Invalid Card Shows Red Light
②Forbid: Gate Access Prohibited 16. Alarm+GND: Fire Alarm Function 17. Limit Sensor 18. IR Signal: Infrared Sensor Optional 19. Power Supply: 24V |
|--|--|

4. Tripod Turnstile & Full-Height Turnstile Circuit Board User Manual

Buttons for Testing:

OPEN-L: Open the left gate

OPEN-R: Open the right gate

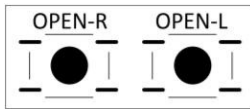

4.1 Buttons for Menu Settings:



MENU (Menu/Confirm button)

1. On the standby screen, press and hold the MENU button to enter the menu.
2. In the menu interface, the MENU button acts as the confirm button. After selecting the corresponding menu, press this button to enter the menu parameter setting interface.
3. After setting the parameters, press this button to save them and return to the system menu interface.

INC (Up/Add button):

Scrolls up to select system menus and increases parameter values by 1.

DEC (Down/Subtract button):

Scrolls down to select system menus and decreases parameter values by 1.

Note: If no button is pressed within 5 seconds in the system menu or menu setting interface, the system automatically returns to the standby screen.

4.2 Menu Parameter Descriptions (F01-F17):

After powering on the circuit board, the LED screen displays <Run>



F01: Passage Duration Setting (default 5 seconds)

Sets the duration for passage. If no one passes within the set time, the gate will automatically close.

Range: 0-255 seconds.

F02: Single Passage Sub-parameter Setting (default 0)

Solenoid configuration

0: Standard solenoid state.

1: Left solenoid normally open.

2: Right solenoid normally open.

3: Both solenoid normally open.

F03: Power-Off Operation Setting (default 1)

0: Free passage (used for full-height turnstiles)

1: Drop arm when power is off (used for tripod turnstiles)

F04: Memory Function Setting (default 0)

0: Memory function off: Multiple cards swiped at once allow only one person to pass.

1: Memory function on: Multiple cards swiped at once allow multiple people to pass in sequence.

F05: Repeated Gate Opening/Closing Test

Used for circuit board aging test. Press the MENU button to exit the test in test mode.

F06: Limit Signal Setting (default 0)

0: Close the gate immediately upon detecting the limit signal (used for tripod turnstiles)

1: Close the gate after the limit signal disappears (used for full-height turnstiles)

F07: Delay for Normally Open Function (default 3 seconds)

Sets the delay duration after which the gate remains open when the normally open function (F02) is enabled. If set to 0, the normally open function is disabled.

F08: Gate Opening Delay Setting (default 1 second)

Effective only when the memory function (F04) is enabled. When multiple people pass continuously, there will be a 1-second pause before reopening the gate to prevent the gate from opening again before the previous person has passed through.

F09: Limit Signal Count Setting (default 1)

Sets how many limit signals are detected before closing the gate in one gate opening cycle. Usually set to 1. For example, setting it to 2 allows two people to pass with one gate opening signal.

F10: RS485 Active Data Upload Switch (default 1)

1: Active upload

0: Query upload

F11: Set RS485 Device Number (default 1)

F12: Left Gate Opening Voice Prompt Setting.

F13: Right Gate Opening Voice Prompt Setting.

F14: Alarm Voice Prompt Setting.

F15: Volume Level Setting.

F16: Restore Factory Settings

When "SYS" appears on the display, press the MENU button again to confirm and restore factory settings.

F17: Exit Menu

Automatically exits if no button is pressed within 5 seconds or by selecting this option.

5. Product Maintenance

5.1 Daily Maintenance

- To avoid the risk of electric shock, always ensure that the power is switched off before inspection.
- Inspect the device regularly to ensure that all parts are in good working condition.
- The device is made of stainless steel. Do not clean it with hard or abrasive materials.
- To remove fingerprints or stubborn stains, clean the surface with soapy water or alcohol, rinse with clean water using a sponge, and wipe dry as necessary.

5.2 Tips and Troubleshooting

A. The turnstile does not open after swiping the card.

- a) Please press the test open button on the circuit board to see if the turnstile can open.
- b) Check if the circuit board receive the open signal.
- c) Check if the opening signal wire loose or not, also Solenoid valve.
- d) Use a multi meter to measure whether there is 24V voltage output at the solenoid valve terminal of the main board, and judge whether the solenoid valve is damaged.

B. Tripod turnstile arms won't drop down when power off

- a) Check if the electromagnet pole drop support is loose, readjust and fix it.

C. When connected to power supply, lift the arm manually, the arm cannot lift. Sometimes, you need to press the turnstile arm all the way down and then lift it up to hold it.

- a) Check if the pole drops support of the electromagnet is loose, test whether the electromagnet is magnetic with a metal object.
- b) Use a multimeter to measure whether there is 24V voltage output at the electromagnet terminal of the circuit board, and judge whether the circuit board has normal voltage output.

D. The circuit board is not energized after power on

- a) Use a multimeter to check whether there is 24V voltage input at the input port.
- b) Check whether the fuse is burnt out.
- c) Check whether there is 24V voltage output at the output end and judge whether the power supply is damage.