

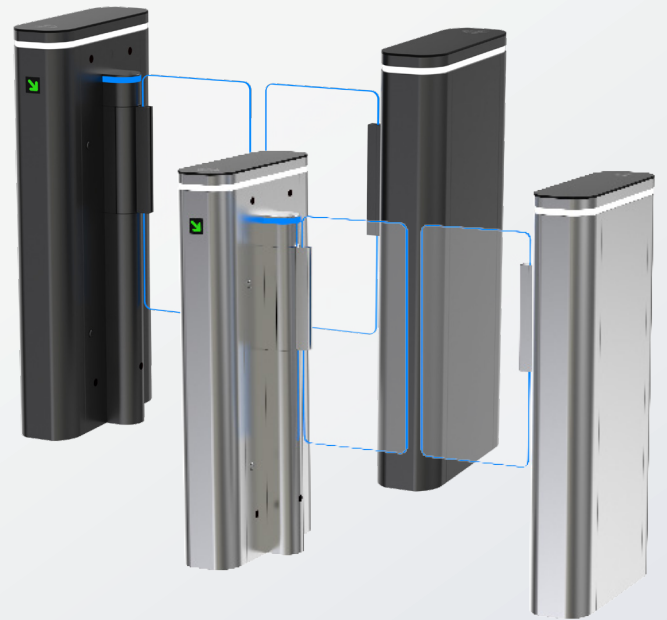

Security Gate

ID GATE 5800



PRODUCT DESCRIPTION

The ID GATE 5800 is a modern security gate designed for efficient access control in high-traffic indoor environments. It is ideal for locations with high visitor numbers, such as airports, office buildings, or public facilities, and offers maximum security and efficiency thanks to its intelligent sensor technology and robust construction.

DIMENSIONS

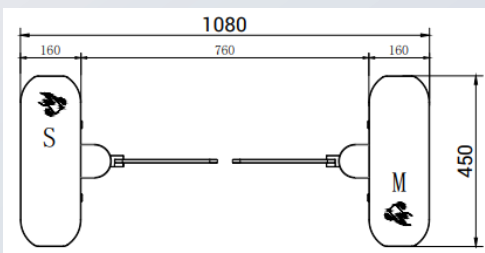
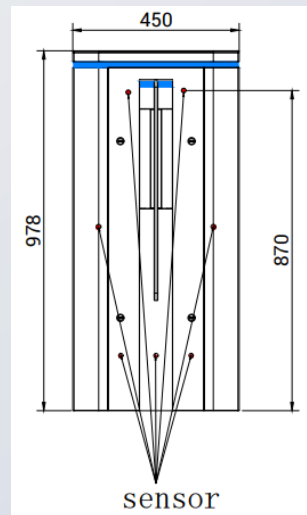
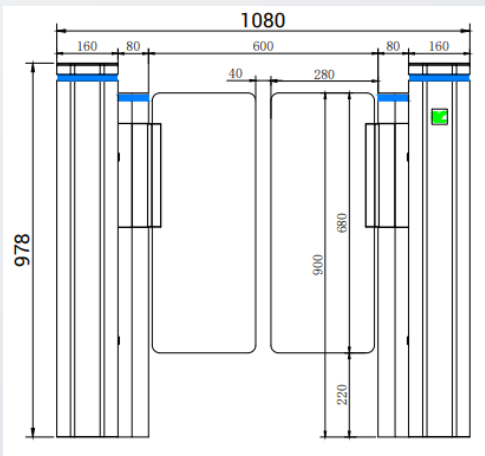

HIGHLIGHTS

- **Efficient access control with high operational reliability**
- **Extremely fast opening and closing time of 0.1 seconds**
- **7 integrated sensors for precise person detection**
- **RGB lighting and LED indicators for directional guidance**
- **Transparent gate wings made of acrylic or tempered glass**
- **Automatic opening of the swing doors in the event of a power failure**
- **High-performance speed gate for indoor use**

Accessories (Optional)

- **iDTRONIC RFID built-in reader R840**
- **QR Code/RFID combo reader ID 1500/1200**
- **Remote control (wired/wireless)**
- **Installation of third-party readers**
- **(e.g., MIFARE, LEGIC, EM, HID, etc.)**

TECHNICAL SPECIFICATIONS

SPECIFICATION	
Dimensions	978 x 1080 x 450mm
Material	Steel - black painted or stainless steel
Power supply	AC220V / 110V, 50/60Hz
Operating voltage	24V DC
Capacity	55 Person per Minute
Emergency mechanism	Automatic opening of the arms when switched off
communication interface	Relay signal, RS485
Sensors	7 pieces per column
Location	Indoor
Protection class	IP54
Operating temperature	-20°C up to +75°C
Humidity	≤90%
Delivery Contents	<ul style="list-style-type: none"> • Stainless steel security gate • Acrylic / tempered glass swing doors • Anchor bolts (M12) + nuts • Wired remote control (for testing purposes only) • Cleaning kit

DIMENSIONS

DIMENSIONS	
Clear acrylic / Tempered glass	Standard: <ul style="list-style-type: none"> • 275x650 mm (600mm Passage width; 900mm Height) • 425x650 mm (900mm Passage width; 900mm Height) • 275x1020 mm (600mm Passage width; 1300mm Height) • 425x1020 mm (900mm Passage width; 1300mm Height)

ORDER CODES

DESCRIPTION	
ID Gate 5800	<ul style="list-style-type: none"> • R-TS-IDG-5800

PRODUCT IMAGES

