

DATASHEET

Capture Module MultiGigabit

General description

The Capture Module (CM) MultiGigabit from Technica Engineering is an active tap device designed to capture 2.5/5/10GBASE-T1 traffic of up to 1 point-to-point 2.5/5/10GBASE-T1 connection (2 ports in total). The received data is captured and HW timestamped without causing interference on the in-vehicle-network (IVN) and sent out to the data sink (e.g. data logger or PC).

Standardized logging protocol

The Capture Module encapsulates logged frames into an ethernet frame adding **valuable** information such as the HW timestamp, Interface ID, Counter and more in a standardized logging protocol header.

Scalable setups

Several Capture Modules can be combined and used together in the same measurement network. The built-in time synchronization feature allows to synchronize the whole measurement network with the same time base. This makes the Capture Modules very scalable and allows to add other IVN technologies to the measurement setup.

Application Areas

Capture Modules are designed to be used in different environments such as in the car, on a development desk or in testbenches. In order to cover these areas as best as possible, the devices allow continuous operation and a wide temperature range.

Optimized logging

The Capture Module is equipped with an internal buffer to store the first frames (sent from the ECUs), even if the data sink is not yet ready. As soon as the data sink is up and ready to receive data, all the stored data will be sent out. With the packetization and output traffic shaping feature the Capture Module can adjust the size of the logging frames and have the possibility to maintain a consistent data flow (to the logger or the test PC). This way it actively prevents forwarding of bursts. The combination of these features ensures that no frames are lost.

Configuration

The CM offers a flexible and user-friendly configuration through its built-in web server. The device webpage can be easily accessed via a standard web browser. In addition, the possibility to import/export a configuration makes it even more convenient.



Capture Module MultiGigabit

Technical Data

Operating Temperature	-40 °C to +75 °C
Supply Voltage	9 V to 24 V DC (typ. 12 V)
Power consumption	15 Watt (depending on connected SFP Modules)
IP Protection Class	IP 20
Dimensions (incl. connectors) W × D × H:	187 × 130 mm × 50 mm
Weight	1,2 kilograms (aprox.)
Interfaces	2x 2.5/5/10GBASE-T1 port (1x link) 2x 10Gbit Ethernet (SFP+) for Logging 2x 1000BASE-T (RJ-45) for Config and Sync 1x Service Port 2x Wake-Up Line
Phy (in-vehicle)	MARVELL 88Q3244 (ACACIA)

Features of the CM MultiGigabit

Devices Features	Configuration Webpage
	Wake-/Sleep
	Import-/Export of Configurations
	Status LEDs
	TECMP / ASAM CMP
	Status Messages*
	Manual IP Configuration via Rotary Switch
	Startup Buffer*
	Cascading*
	Hardware Timestamping with nanoseconds of resolution
	Time Synchronization (gPTP/802.1AS-2011 AVnu profile or PTPv2 subset)
	Packetization*
	Output Traffic Shaping*
Basic + Advanced Filtering	
Sync + Link Events	
Traffic Injection	

*currently not implemented for ASAM CMP

Use case

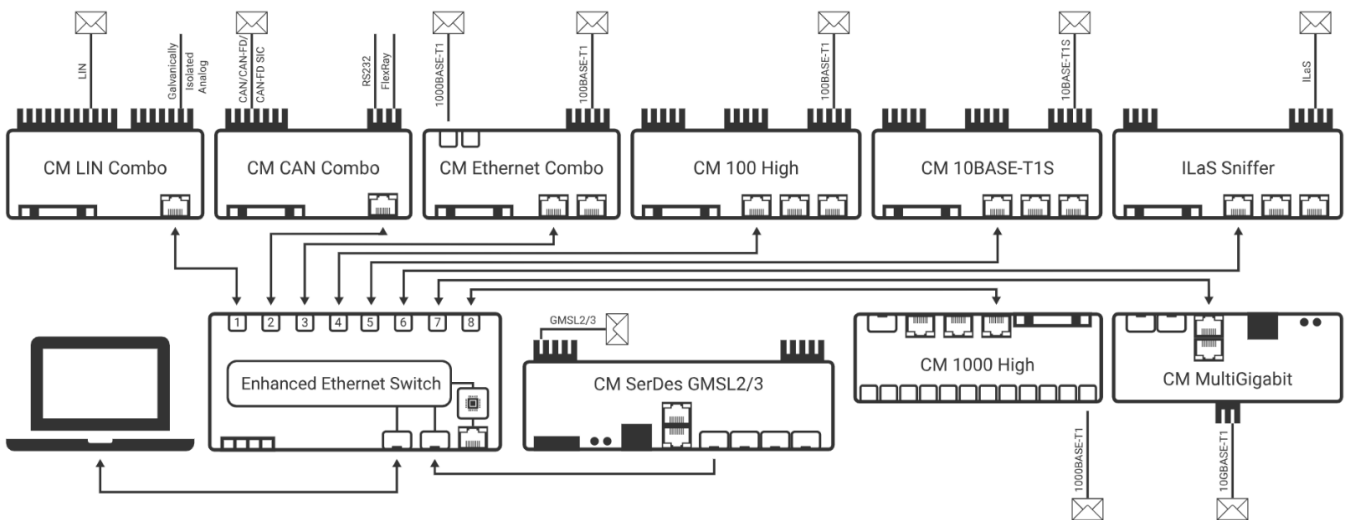

Order Information

Name	Product article number	Cable set article number*
Capture Module MultiGigabit	TE-1191	KS-1191

* Needs to be ordered separately