

MEC MICRO 19

SCISSOR LIFT

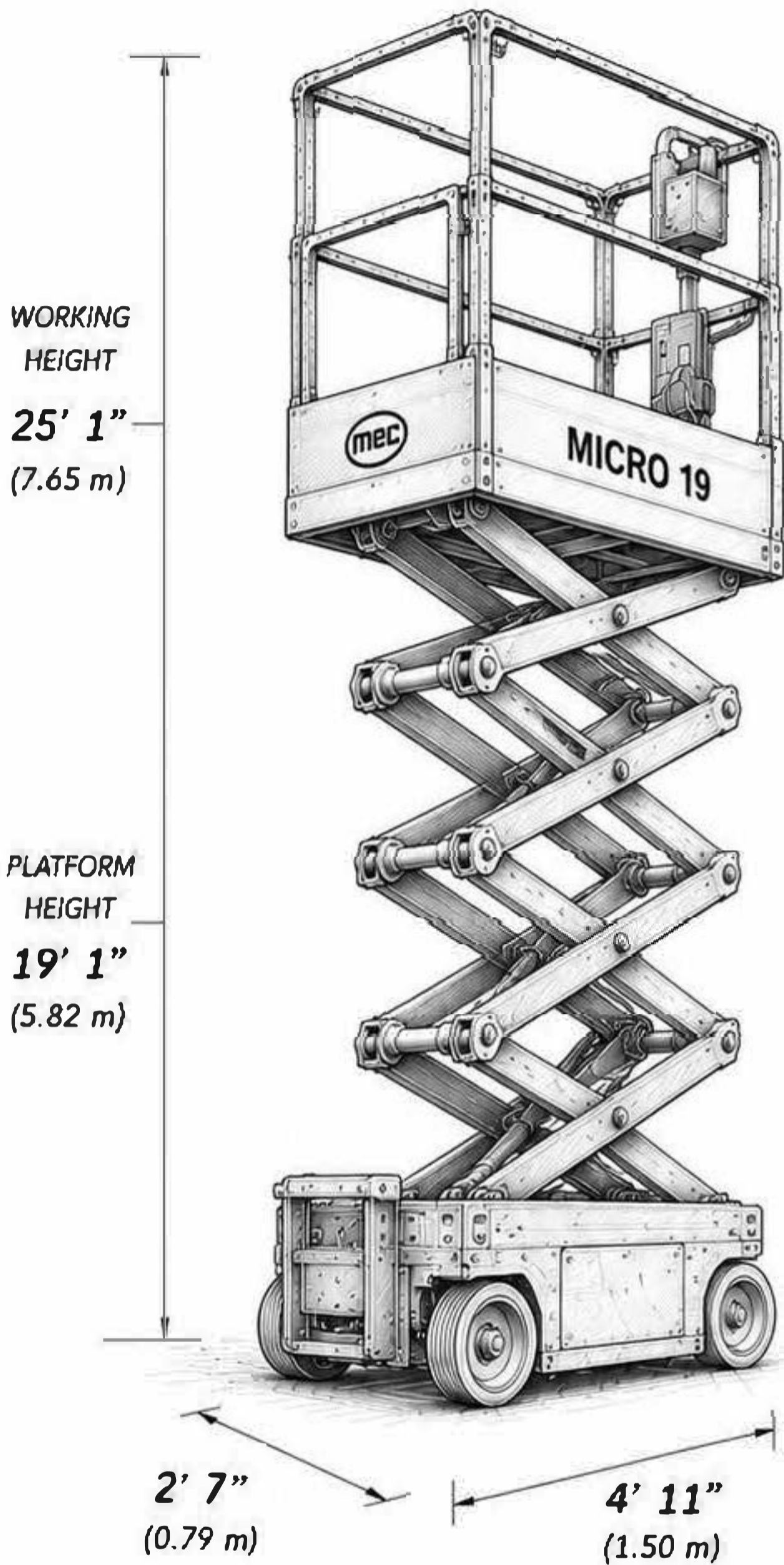

SPECIFICATIONS

Working Height	25 ft 1 in (7.65 m)
Platform Height	19 ft 1 in (5.82 m)
Platform Capacity	500 lb (227 kg)
Platform Extension Capacity	250 lb (113 kg)
Platform Size (Std.)	21.5 in x 49 in (0.55 m x 1.24 m)
Deck Extension	20 in (0.51 m)
Overall Width	31.5 in (0.80 m)
Overall Length	4 ft 11 in (1.50 m)
Stowed Height (Rails Up)	6 ft 7 in (2.01 m)
Stowed Height (Rails Down)	4 ft 9 in (1.45 m)
Weight	1,984 lb (900 kg)
Drive Speed (Stowed)	2.0 mph (3.2 km/h)
Drive Speed (Raised)	0.5 mph (0.8 km/h)
Power Source	24V DC (Four 6V Batteries)
Tires	12 x 4 in Non-Marking Solid

BEST FOR

- Indoor Construction
- Warehouse & Retail
- Maintenance & Facility Work
- Electrical & HVAC



Extension Deck



Leak Containment System



Non-Marking Tires



Zero Emissions



844-935-3960



stackequipment.com



Now Serving
WI - FL - TX - NC