



**RUBBER & PTFE**  
DIAPHRAGMS

Product  
Catalogue





## CONTENTS

Page No.

---

<b>01</b>	Diaphragms by Western Sealtech
<b>03</b>	Role of Rubber & PTFE Diaphragms
<b>03</b>	Why Choose Western Rubbers?
<b>04</b>	Diaphragm Construction Capabilities
	<a href="#">Diaphragm Classification</a>
<b>08</b>	Rolling (Actuator) Diaphragms
<b>14</b>	Valve (Weir Type) Diaphragms
<b>18</b>	Pump Diaphragms
<b>22</b>	Material Comparison Chart
<b>24</b>	Fabric Comparison
<b>26</b>	About Us
<b>27</b>	Our Clientele / Brochures & Catalogues



## DIAPHRAGMS BY WESTERN RUBBERS

---

With its inception in 1972, Western Sealtech has grown to be a market leader in manufacturing industrial rubber and PTFE diaphragms. After years of R&D, today Western Rubbers possesses the capabilities of custom engineering innovative and cost-effective molded diaphragm solutions that are critical to the operation of essential mechanisms across a range of industries like Petroleum, Pumps and Valves, Industrial, Aerospace, Pharmaceutical, Food and Beverage Processing Plants, Gas Regulator/Metering, and many more.

Diaphragms are used in a range of industries across the globe, like in assemblies of pumps, valves, and actuators to regulate the flow and transfer of fluids. Rubber/PTFE diaphragms function as flexible barriers between two chambers, preventing the movement of fluids or contaminants from one chamber to another. They may be static or dynamic rubber seals.



## ROLE OF RUBBER & PTFE DIAPHRAGMS

Rubber/PTFE diaphragms function as flexible barriers between two chambers, preventing the movement of fluids or contaminants from one chamber to another. They may be static or dynamic rubber seals. Western Sealtech is a leading manufacturer of PTFE and rubber diaphragms with a global distribution network. Diaphragms are used in a range of industries across the globe in assemblies of pumps, valves and actuators to regulate the flow and transfer of fluids.

### WHY CHOOSE WESTERN SEALTECH?



#### In-house Tooling & Compounding

- All molds are custom fabricated in-house to meet customer specifications
- Quick turnaround time, hence reducing overall project lead times

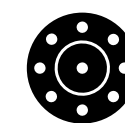

#### OEM Replacement Diaphragms

- OEM replacement diaphragms manufacturer
- Superior grade selection & in-house processing ensures diaphragms have the best flex life in the industry
- Reasonably priced compared to OEM and significant cost reduction on bulk purchasing

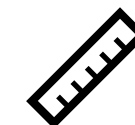

#### Extensive Product Capability

- Diaphragm sizes range from ¼" to 55" diameter
- Specific elastomers can be used to withstand extremes of temperatures (-100C to +300C)
- Fabric reinforcements can also be used to withstand pressures up to 1000 psi (68 bar)



#### Customer Satisfaction

- Complete guidance throughout the process, from prototyping to dispatch
- Fast turnaround on quotations, prototypes, repeat orders, etc.
- All parts are 100% quality tested

## DIAPHRAGM CONSTRUCTION CAPABILITIES

by Western Sealtech

One of Western Sealtech' core competencies is manufacturing diaphragms for valves, pumps and actuator applications. Over the years, with continuous Research and Development, Western Sealtech can manufacture a range of diaphragms that can handle a variety of mediums (viscous fluids, semi-solid mixtures, reactive mediums, corrosive particles, etc.) without leakage. The guaranteed performance of Western Rubbers' diaphragms is the result of our stringent quality control and continuous development.

### HOMOGENEOUS RUBBER DIAPHRAGM

Rubber diaphragms, also known as homogeneous diaphragms, are similar to fabric reinforced diaphragms, except without the layer of fabric reinforcement. They are preferred for low pressure applications.



### FABRIC REINFORCED DIAPHRAGM

Fabric reinforced diaphragms have a layer of fabric sandwiched between two elastomer layers. The fabric enables the diaphragm to withstand higher pressures, while offering flexible movements during the process.



### INSERT MOLDED DIAPHRAGM

These diaphragms have metal inserts bonded into the diaphragm. During the molding process, the insert is completely or partially inserted into the elastomeric layers, thus creating a strong bond between the two. This helps eliminate the costs incurred for assembling the diaphragm in pumps or valves.

### PTFE DIAPHRAGM

PTFE belongs to the fluoroplastics family. It is highly chemically inert. And hence, offers excellent chemical resistant properties in some of the most corrosive environments. It can withstand temperatures up to 260 C.



### LAMINATED DIAPHRAGM

Laminated diaphragms have a PTFE sheet bonded with rubber. The PTFE layer offers resistance against corrosive chemicals, thereby increasing the life of the diaphragm. These diaphragms are cheaper in cost compared to PTFE diaphragms.

### MOLDED DIE CUT DIAPHRAGM

Molded die cut diaphragms can be made available in any shape or size. They are cut molded from rubber sheets. They can be made with or without a fabric reinforced layer.



# DIAPHRAGM CLASSIFICATION

---

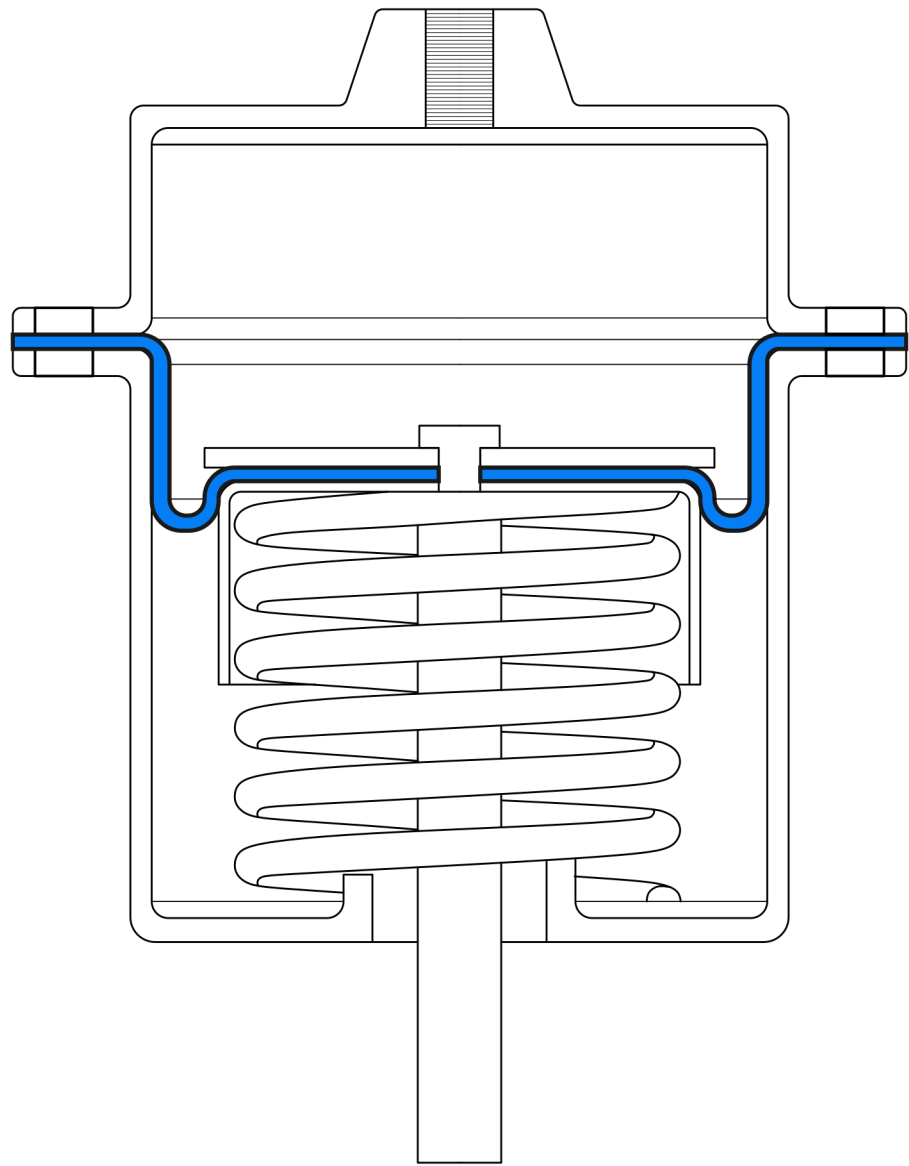

A. ROLLING (ACTUATOR) DIAPHRAGMS

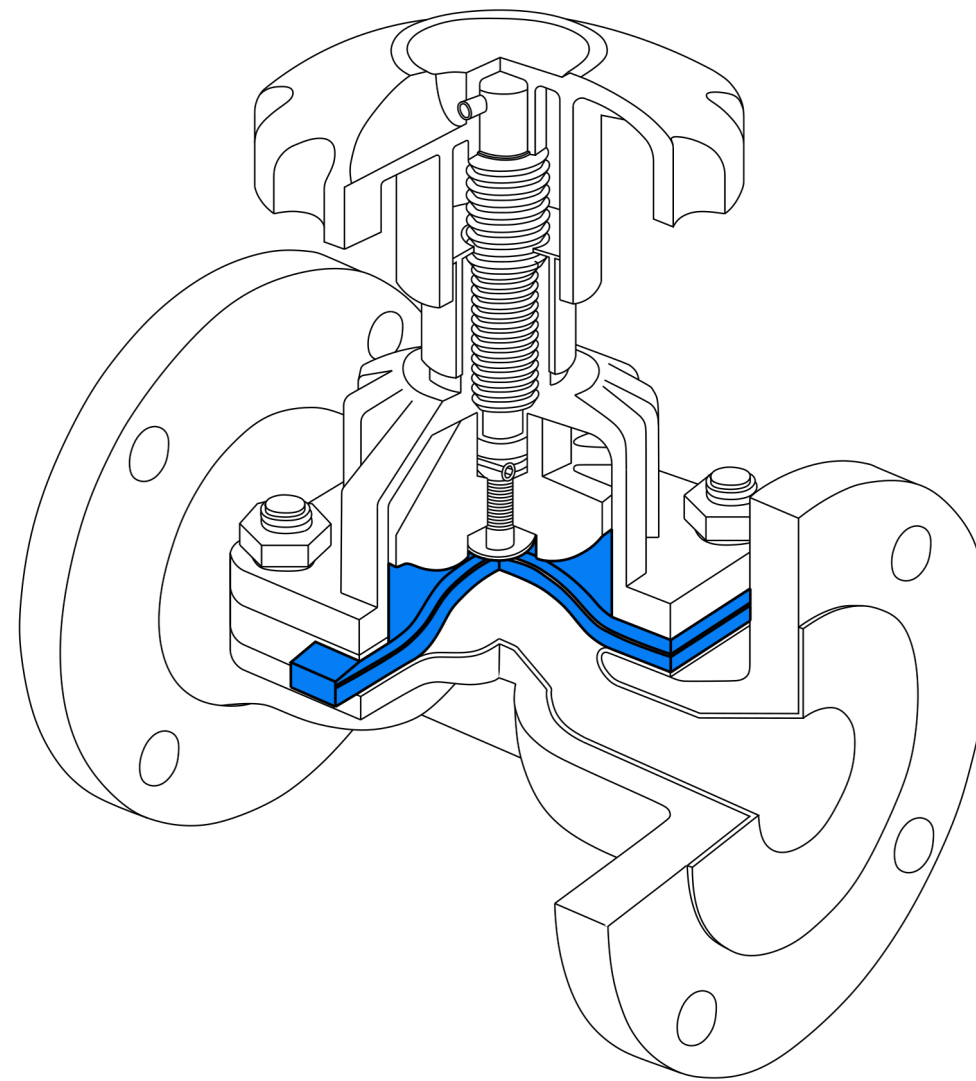

B. VALVE (WEIR TYPE) DIAPHRAGMS

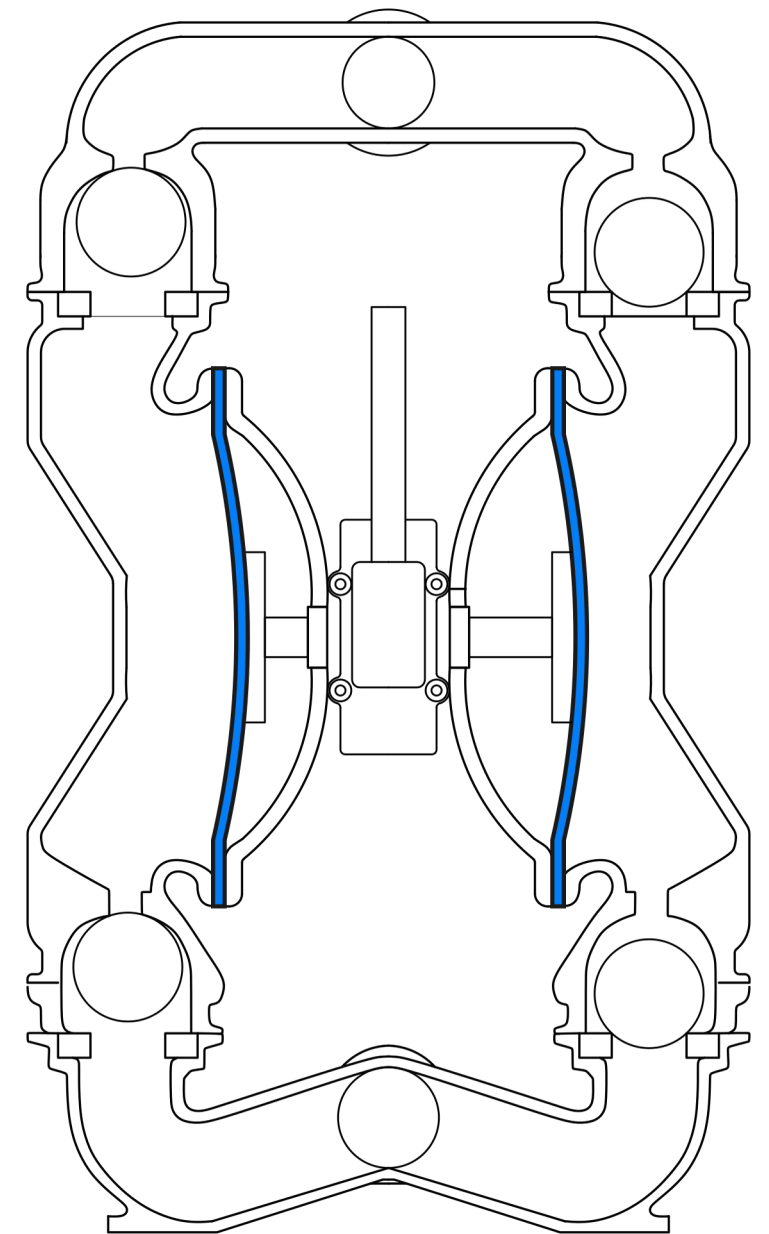

C. PUMP DIAPHRAGMS

## A. ROLLING (ACTUATOR) DIAPHRAGMS

Rolling diaphragms manufactured by Western Sealtech, are flexible fluid control devices. They find critical application in systems involving sealing function between a cylinder and piston. Rolling diaphragms are usually manufactured using a combination of elastomer and fabric i.e. a layer of fabric reinforcement sandwiched between two elastomeric layers.

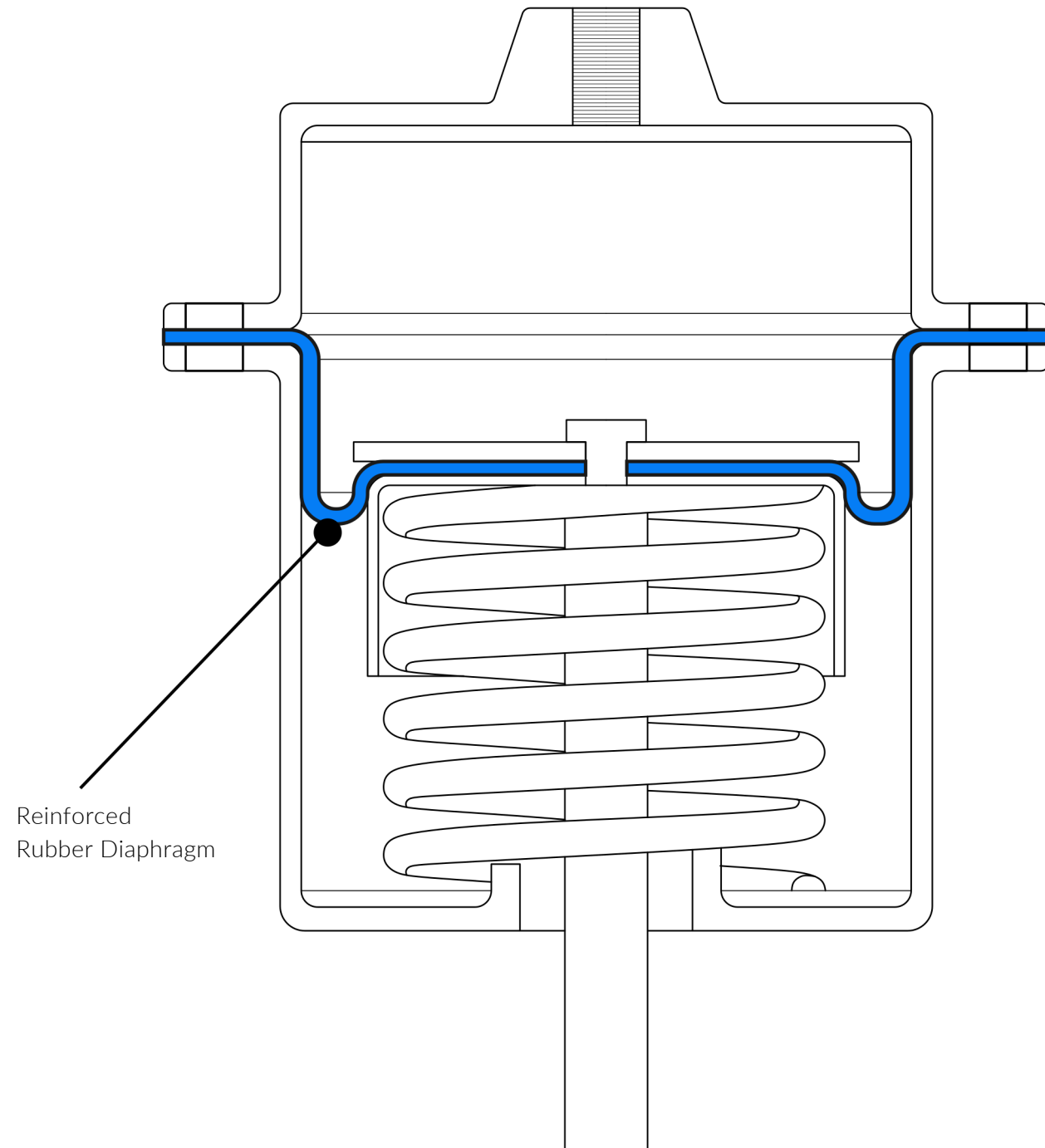

### NEED FOR ROLLING DIAPHRAGMS

Rolling diaphragms find their application in industries that require high performance in harsh environments, such as the chemical processing, automotive, food and beverages, aerospace and medical industries. Known for their accurate, repeatable positioning, rolling diaphragms can offer long stroke lengths, and no spring rate, i.e. the force caused by rubber trying to return to its molded position.

The rolling diaphragm rolls and unrolls alternately on the piston skirt and cylinder wall. A semi-circular “convolution” in the diaphragm is formed between the piston and cylinder wall. This convolution rolls as the piston moves up and down. The rolling action is smooth and eliminates sliding contact and breakaway friction. It forms a perfect barrier, preventing leakages and pressure loss. A variety of flange designs for diaphragms are available depending on the application.

## MATERIAL SCOPE

### Rubber Diaphragms with Fabric Reinforcement

Western Sealtech can manufacture rolling diaphragms in a range of elastomers like Silicone, EPDM, FKM, Nitrile, etc. Each elastomer comes with its unique properties\*.

Rolling diaphragms have a high strength fabric reinforcement layer sandwiched between two maximum elastomeric layers, thus ensuring strength and durability. This fabric layer not only offers high tensile strength to the diaphragm, but is also designed to permit smooth rolling action of the diaphragm.



\*Check Western Rubbers' Material Comparison Chart on page 22 for more details on elastomer & material properties.

## TYPES OF ROLLING DIAPHRAGMS

### Type 1: Flat Flange Diaphragms

Flat Flange Diaphragms are the most commonly manufactured rolling diaphragms. Applications that have flat mating surfaces between the cylinder and the piston prefer the installation of these diaphragms. The flanges of the diaphragms basically serve as a sealing gasket to prevent leakages at the parting section.

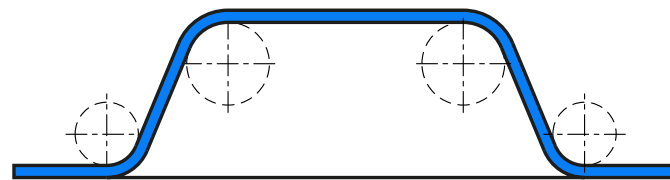

### Type 2: Crimped Diaphragms

Crimped Diaphragms need not be inverted at the time of installation since the convolution is molded in the "as-installed" configuration. Since it is not economical and practical to manufacture diaphragms with deep convolutions, Crimped Diaphragms have a limited stroke suitable for applications with limited strike length.



### Type 3: Beaded Flange Diaphragms

Beaded Flange Diaphragms have a flange which looks similar to an O-ring. The diaphragm is sealed via axial compression of the D shaped bead. The application for these diaphragms is configured in a way so as to provide for installation of the bead in a mating groove. Owing to the principles of compression set, the D shaped bead might lose some of its effectiveness with time and use at high pressures. And hence, this design is not recommended for applications where the differential pressures could exceed 10 bar.

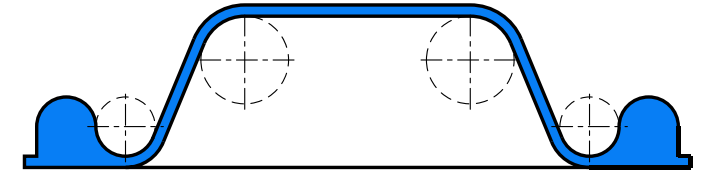

### Type 4: Beaded Flange Crimped Diaphragms

Beaded Flange Crimped Diaphragms combines the properties of both Type 2 and Type 3 diaphragms. These diaphragms are also molded in the "as-installed" configuration and hence do not require inversion at the time of assembly. Since no inversion is required, a flat retainer plate is sufficient to retain the head of the diaphragm to the piston.



### Type 5: Internal Beaded Flange Diaphragms

The Internal Beaded Flange Diaphragms comprise of a rectangular bead running internally around the circumference of its mounting edge. This configuration offers a minimum outside housing diameter. Since the flange bead is on the inside of the cylinder, this stroke capability of the diaphragm is usually restricted to half stroke.

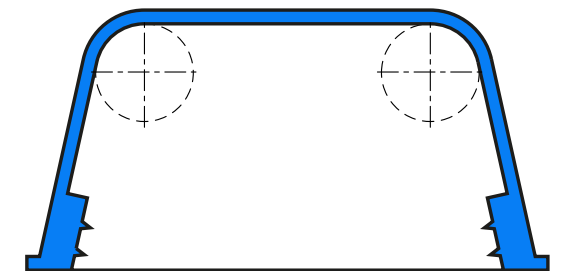

## B. VALVE (WEIR TYPE) DIAPHRAGMS

Valve diaphragms by Western Sealtech are sturdy and flexible seals that allows for opening, closing and controlling of the valve. Diaphragms are carefully engineered for enhancing valve performance, promising superior flex life, saving significant labour costs and guaranteeing excellent sealing functionality.

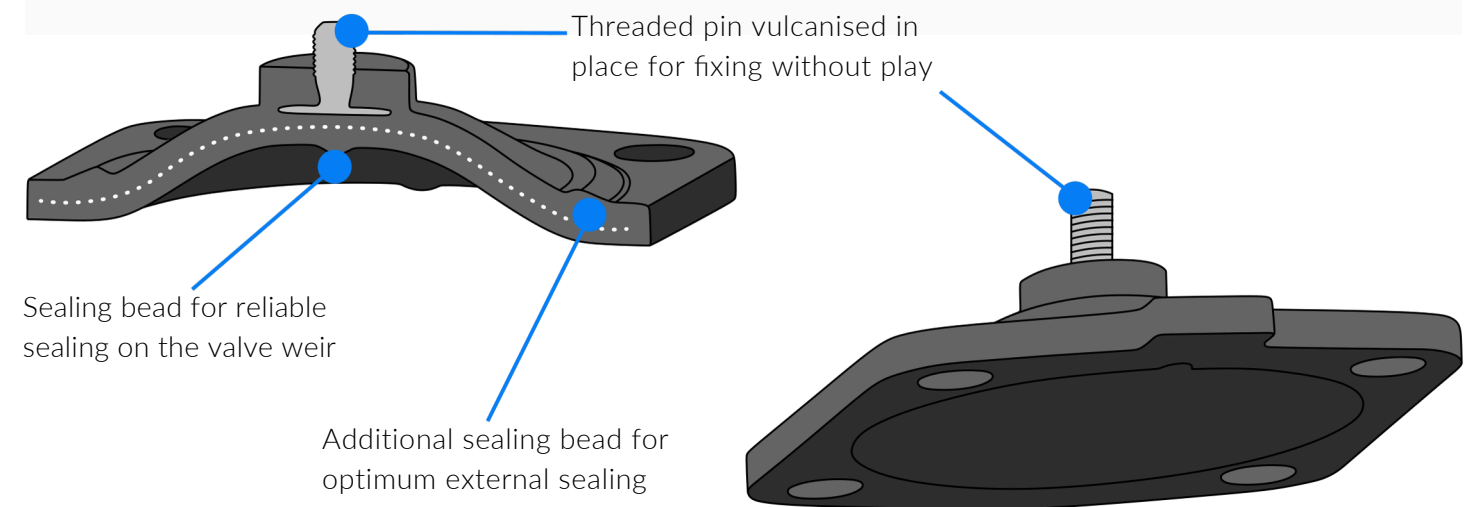
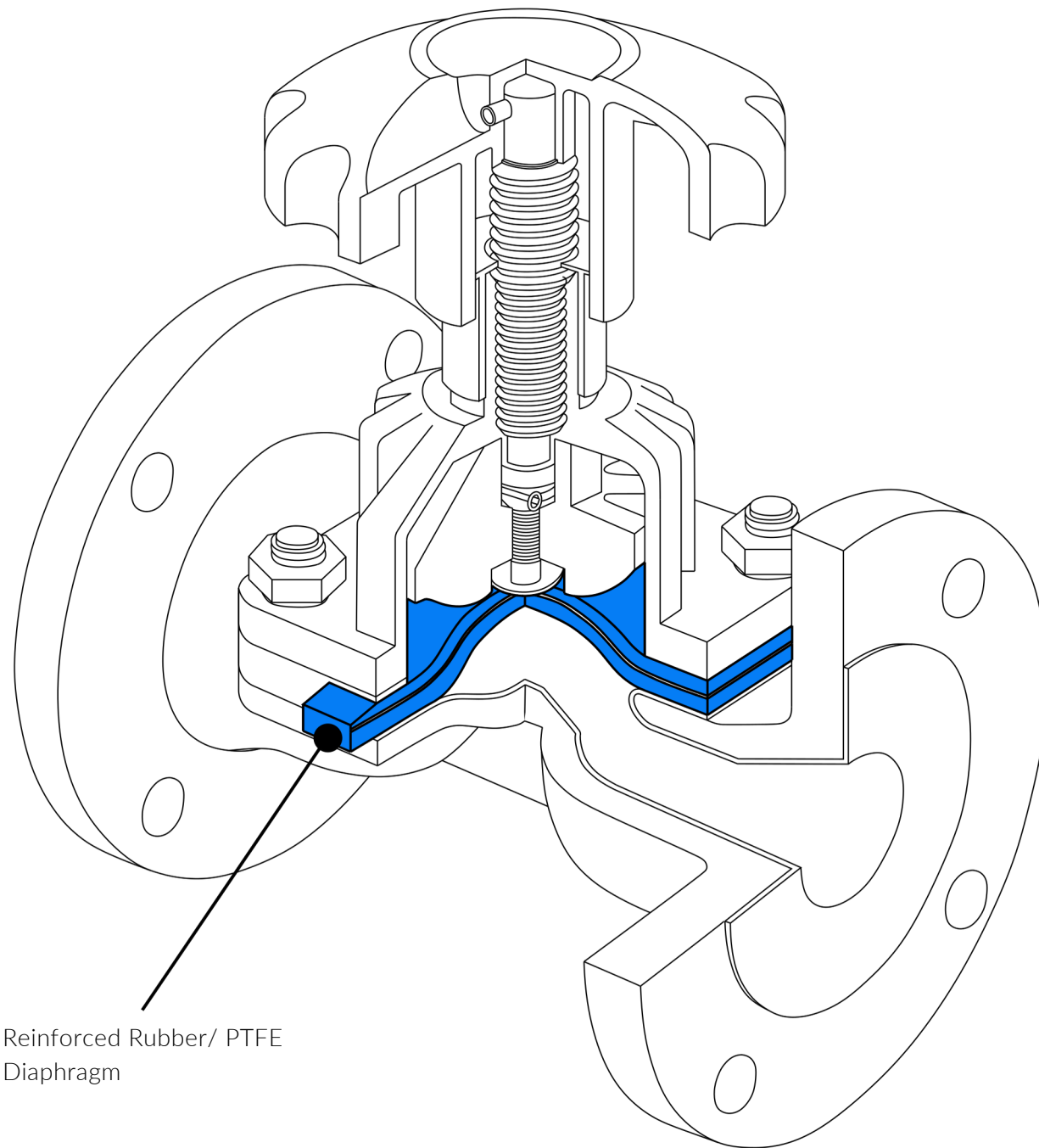

### NEED FOR WEIR TYPE DIAPHRAGMS IN VALVES

The weir-type diaphragms are the most popular type of diaphragms. They are ideal for applications that involves handling of corrosive and abrasive mediums that make use of weir-type diaphragm valves. The bonnet over the diaphragm and actuator ensure the valve is kept leak proof. The raised lip on the diaphragms is ideal for controlling small-medium flows, without having the material stretch too far. In fact, Weir type diaphragms are also the preferred choice for high pressure and vacuum applications.

## MATERIAL SCOPE

### Rubber Diaphragm

Western Rubbers manufactures diaphragms in a range of elastomers like Silicone, EPDM, FKM, Nitrile, etc. Each elastomer comes with its unique properties\*. And hence, depending upon the application, Western Rubbers' engineers offer guidance in selecting the most appropriate elastomer. Rubber diaphragms have high strength fabric reinforcement layer sandwiched between two elastomeric layers, thus ensuring maximum strength and durability.

\*Check Western Sealtech' Material Comparison Chart on page 22 for more details on elastomer & material properties.



### PTFE Diaphragms

#### a. PTFE + Rubber Padded

A two piece construction, comprising of a PTFE diaphragm along with a support rubber diaphragm, provides for increased pressure rating and durability. PTFE belongs to the fluoroplastics family. It is among the most chemically inert materials. And hence, offers excellent chemical resistant properties in some of the most corrosive environments. It can withstand temperatures up to 260 C. This diaphragm set comes with a bayonet fitting, thus ensuring reliable installation, reduced point loading and maximum life.



#### b. PTFE Laminated

Western Sealtech possess the competencies to fabricate PTFE-Rubber composite diaphragms i.e. PTFE lamination ranging in thickness from .002" up to .040" bonded to a rubber diaphragm. The PTFE lamination makes the diaphragms capable of functioning in the most chemically aggressive environments without compromising on the functionality and life of the diaphragm. For additional strength, a layer fabric reinforcement may be added to the PTFE/rubber composite. Bonded inserts of stainless steel, brass, plastic are often incorporated into these diaphragms to reduce assembly steps at the time of installation.



## CONSTRUCTION- OPEN & CLOSED MOLDED CONSTRUCTION

Open and closed diaphragm designs depend on valve types which maybe normally open or normally closed. Westerns Sealtech possesses the manufacturing capabilities for fabricating both, open and closed molded diaphragms designs.

### Open Molded Construction

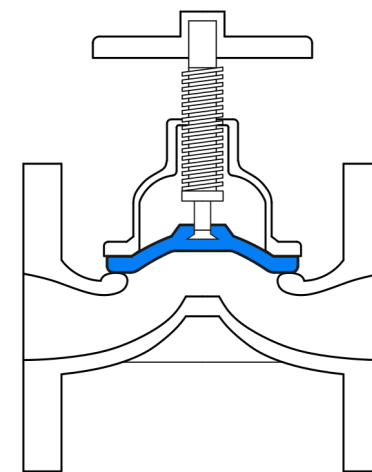

Open molded diaphragms are used in normally open valves which to allow the medium to flow through in usual circumstances. These devices will remain open until power is sent to the coil, signalling the plunger to close. And hence, diaphragms are molded to accommodate this design, thus offering effective sealing along with an extended operational life.

### Closed Molded Construction

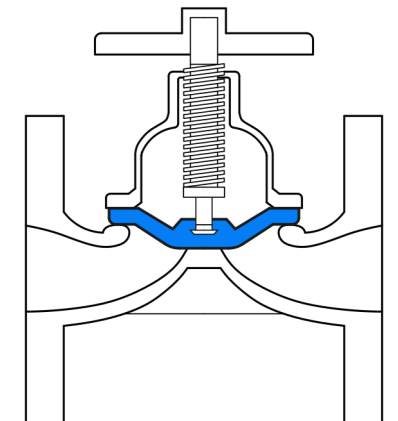

Closed molded diaphragms are used in valves which are normally in a closed position. These valves are designed to block the flow of the medium in normal conditions and are commonly found in emergency safety systems. The valve will open when the system begins to experience overpressure to ensure safety. Closed diaphragms are molded to accommodate the design of normally closed valves.

## DIAPHRAGM FITTINGS

Western Sealtech not only offers a versatile range of diaphragms but also a versatile range of diaphragm fittings as required by the customer. The different diaphragm fittings offered by Western Sealtech include:

### Threaded Pin

As the name suggests, threaded pins are screwed into the actuator.



### Bayonet Fitting

Bayonet Fittings have a pin fastened in the actuator by a 1/4 turn for very easy trouble-free connection.



### Rubber Button

Rubber Buttons are elastomeric knobs that enable integration in the actuator (manual or pneumatic)



## AVAILABLE SIZES

Western Sealtech has standard molds available for manufacturing valve diaphragms in the following sizes:

By valve size: In Rubber: DN 8 to DN 350 In PTFE: DN 8 to DN 100

Since we have a complete in-house set up for tolling and manufacturing, we can also custom make valve diaphragms to precisely meet the requirements of your application.

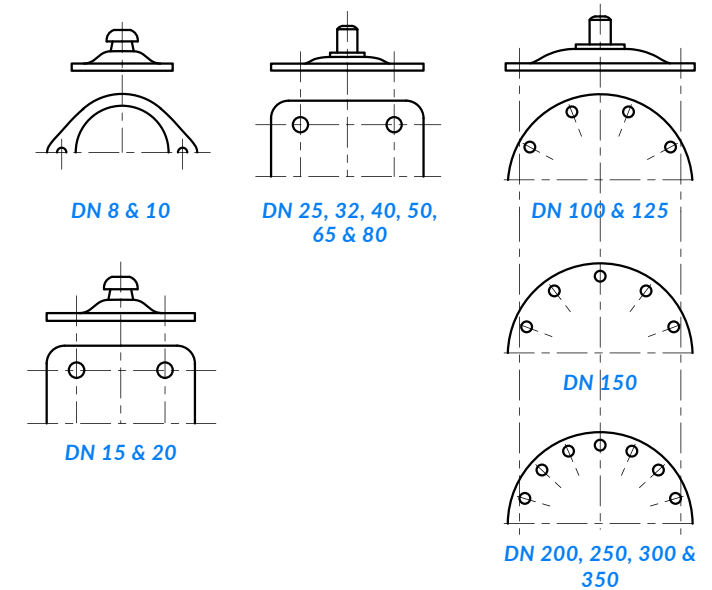

## APPLICATIONS

Valve diaphragms find their application in a wide range of industries like:



Oil and Petroleum



Fuel and Power

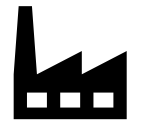

Chemical Processing Plants



Pulp and Paper



Cement

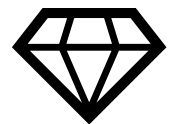

Mining and Minerals

Valve Diaphragms are the Ideal Choice for:

- Corrosive mediums
- Abrasive applications
- Slurries
- Viscous mediums

## C. PUMP DIAPHRAGMS

Along with diaphragms for valves, Western Sealtech possesses the capabilities to manufacture pump diaphragms too. Diaphragms can be custom molded in various designs depending on customer specifications. Having a diaphragm for every industry; handling reactive chemicals to aggressive fluids to extremes of temperatures, Western Sealtech ensures your requirement is fully met with the best possible diaphragm to optimize chemical compatibility, abrasion resistance, functional life, temperature limit, and cost.

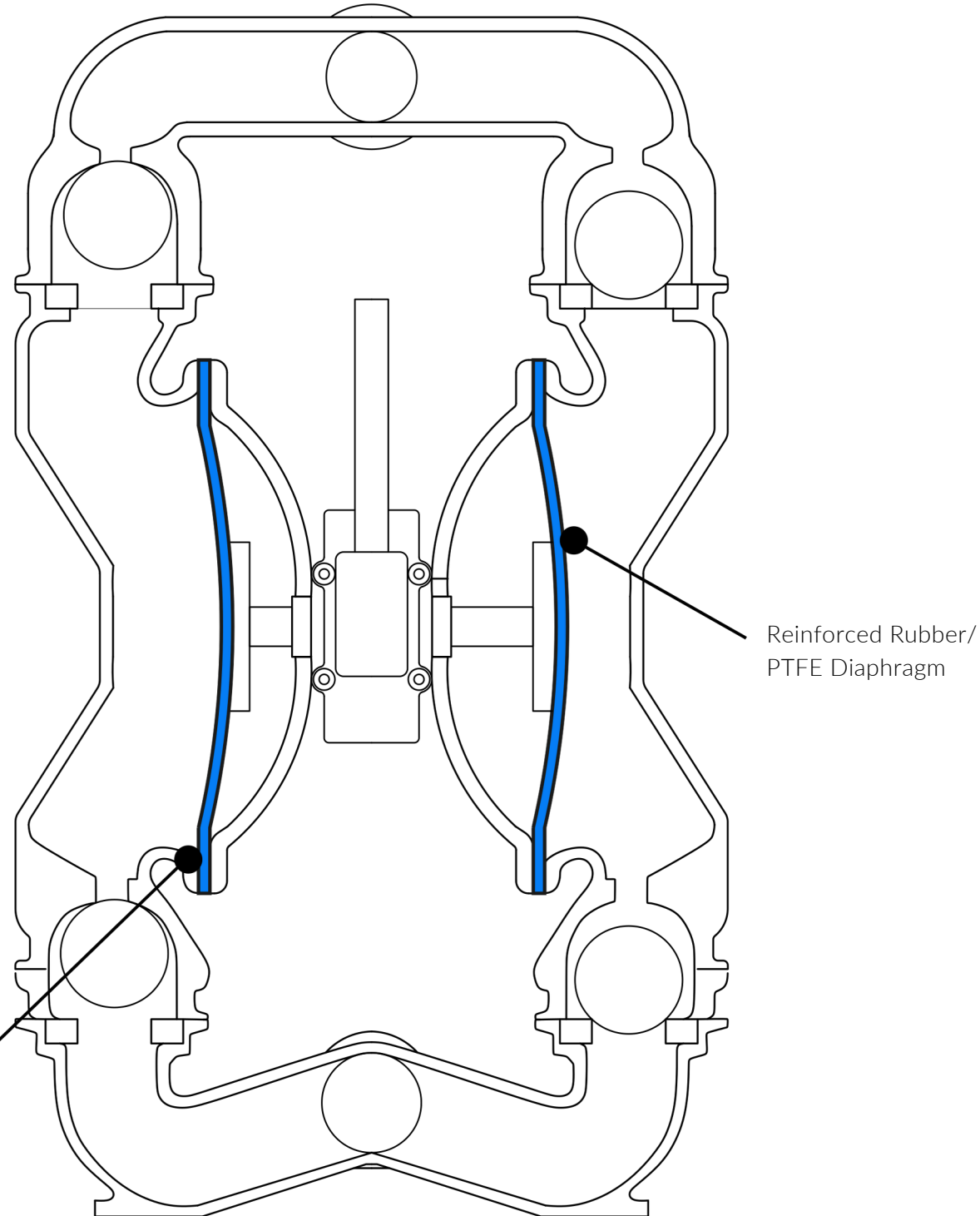

### NEED FOR DIAPHRAGMS IN AODD PUMPS

A versatile workhorse, an AODD (Air Operated Double Diaphragm) pump enables users across a variety of industries to standardise on a single pump type that for handling difficult and reactive fluids. This easy to use pump can be installed anywhere, as long as there is a supply of compressed air. It is safe to say that a suitable diaphragm is among the most critical components of an AODD pump. The pump will simply fail in its purpose if there is any kind of leakage. Hence, selection of a correct diaphragm is extremely crucial for the safe, efficient, economic and hassle-free operation of an AODD pump.

## MATERIAL SCOPE

Western Rubbers offers a number of material options that have been researched upon and tested extensively over the years for use in diaphragms in AODD pumps. These materials\* can be grouped into three main categories:

### Rubber Diaphragm

Western Rubbers manufactures diaphragms for AODD pumps that are capable of functioning in extreme environments, in natural as well as man-made elastomeric compounds. Rubber diaphragms offer temperature flexibility, along with extended flex life and increased chemical resistance. Western Rubbers manufactures diaphragms in a range of elastomers like EPDM, Neoprene, FKM, Nitrile, etc. Each elastomer comes with its unique properties. Hence, depending upon the application, Western Rubbers' engineers offer guidance in selecting the appropriate elastomer. The fabric reinforcement layer sandwiched between the elastomer layers gives the diaphragm superior strength and exceptional durability.



### PTFE Diaphragms

Western Sealtech PTFE diaphragms are the ideal choice for aggressive chemical applications. Being a chemically inert material, PTFE can withstand aggressive applications such as aromatic or chlorinated hydrocarbons, acids, caustics, ketones, etc. It is also the optimal choice for aldehydes and acetates. Along with offering excellent resilience and durability, PTFE diaphragms promise superior flex life too.



### PTFE + Rubber Back up

PTFE diaphragms can be offered with an elastomeric support/back up diaphragm in materials like EPDM, Buna-N, Neoprene, or TPE.



\*Check [Western Sealtech Material Comparison Chart](#) on page 22 for more details on elastomer & material properties.

## AVAILABLE SIZES

Western Sealtech has standard molds available for manufacturing pump diaphragms in the following sizes:

By pump size: AODD 15, AODD 150, AODD 30, AODD 300, AODD 40, AODD 50, AODD 80  
By inch size: 1/2", 1", 1 1/2", 2", 3"

Since we have a complete in-house set up for tolling and manufacturing, we can also custom make pump diaphragms to precisely meet the requirements of your application.

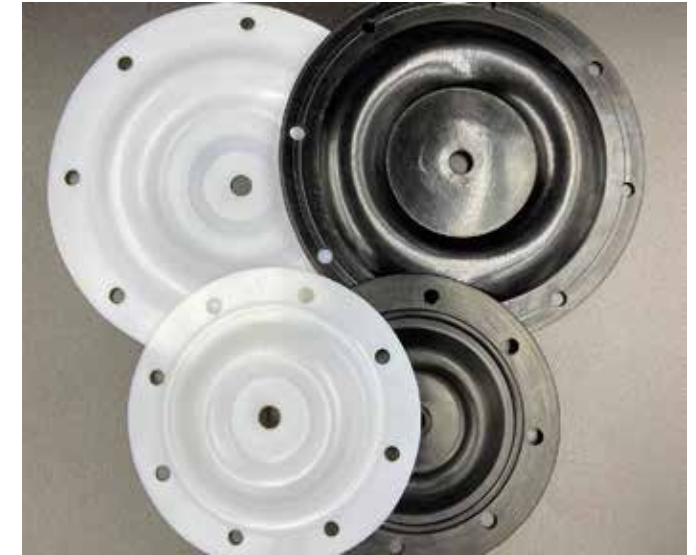

## APPLICATIONS

Diaphragm pumps are a common site in many industries across the globe. Industries involving handling of difficult fluids such as:



Viscous & Sticky Fluids



Abrasive Slurries



Corrosive Chemicals



Smaller Solids



Creams, Gels & Oils



Aggressive Solvents



## FABRIC COMPARISON

Fabric reinforced diaphragms are used in extreme pressure/temperature applications. The fabric reinforcement adds to the diaphragm's overall strength. Fabrics are cautiously molded within the diaphragm using special processes by highly skilled labor.

Every fabric differs in its properties. Hence, the functioning of the diaphragm is carefully studied by our production engineers for selection of the appropriate fabric. Some fabrics used will have limitations with regards to the thickness of the fabric that can be used within the part, the temperature it can withstand during operation, and more. Western Sealtech uses the following fabrics for crafting fabric reinforced diaphragms:

### NYLON

Nylon is one of the most commonly used fabrics in our rubber diaphragms. It is a tough and abrasion resistant fabric. Further, being strong as well as flexible, it enhances the dynamic properties of diaphragms. Nylon can resist temperatures up to 250 °F.

### DACRON®

Dacron exhibits very good tensile properties, and therefore is the preferred option in applications where high flexibility is required. Being chemically inert, it offers good resistance to degradation by chemical bleaches and to abrasion. Dacron is especially effective in applications where the temperature is higher than 250°F (120°C).

### NOMEX®

Nomex is a step above Dacron in its temperature and chemical resistant properties. Nomex products are strong, resilient and (in the thinner grades) flexible, with good resistance to tearing and abrasion. It is sold in both fiber and sheet forms and is used as a fabric wherever resistance from heat and flame is required. Nomex can resist temperatures up to 450°F.

### KEVLAR®

Kevlar is a heat-resistant and strong synthetic fiber. It is lightweight, durable and extraordinarily strong. Kevlar is by far the strongest fabric Western Sealtech uses, and more expensive compared to other fibers. However, it can only be used in larger cross sections due to its thickness. It exhibits excellent heat resistant properties and decomposes above 400°F without melting. The same high temperature resistance as Nomex with approximately three times the strength.

## FABRIC STRENGTH AS COMPARED TO NYLON

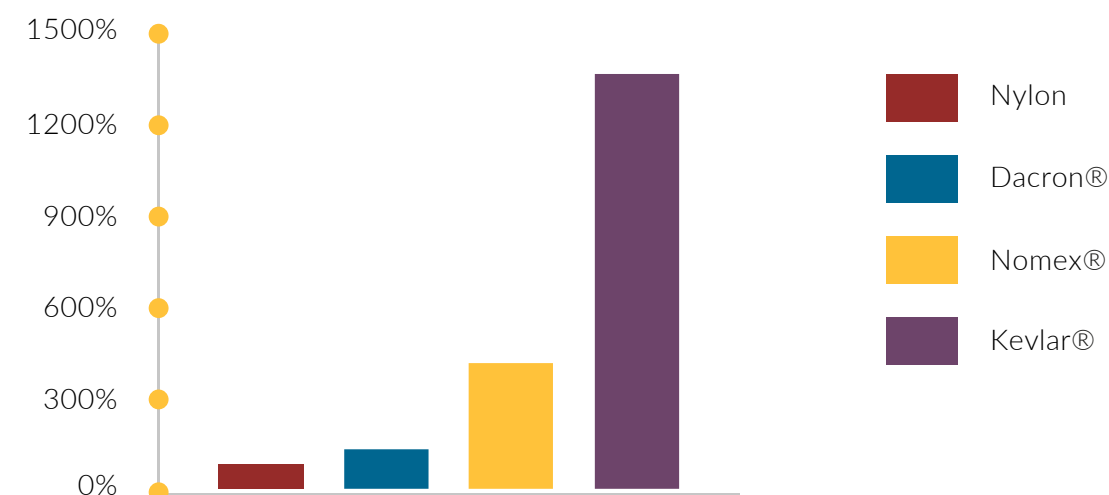

## STRENGTHS OF TYPICAL INDUSTRIAL YARNS AT ELEVATED TEMPERATURES

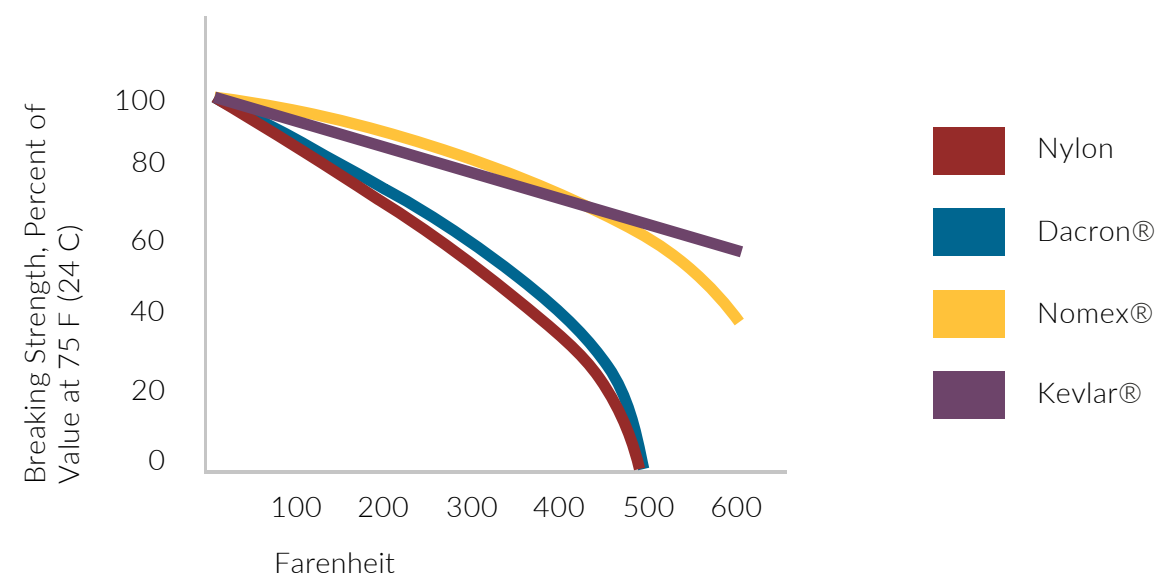

\*Dacron®, Nomex®, and Kevlar® are registered trademarks of E. I. du Pont de Nemours and Company or its affiliates. Typical Industrial Yarn Strength chart is also courtesy of E. I. du Pont de Nemours and Company or its affiliates.

## ABOUT US



Western Rubbers is a globally recognized company that was established by Late Mr. Kanubhai Shah in 1972. The company had a humble beginning in a small garage with an area of 100 sq feet, but has since expanded to become a family of over 150 people, with its headquarters located in Mumbai, India, and 2 manufacturing plants in Umbergaon (Gujarat), India, as well as a sales office in Delaware, USA.

We owe our success to the hard work and dedication of our founder, Mr. Kanubhai Shah, and we express our sincere gratitude to him. Today, Western Rubbers is a thriving company that serves customers around the world with its high-quality products. Our growth and expansion over the years are a testament to our commitment to excellence and our passion for innovation.

### COMPANY OVERVIEW

- 100+** Employees
- 36,00 Sq Ft.** Facility Area
- 200+** Global Customers
- 40+ Countries** Market Presence
- 100 Tonnes p.a.** Materials Consumed
- 15+** Polymers Used
- 5000+** Number of Molds Made

## OUR CLIENTELE





## OTHER BROCHURES & CATALOGUES



by western rubbers

- 



**COMPANY PROFILE**  
VIEWON OURWEBSITE  
<https://www.westernsealtech.com/knowledge-center/>

- 



**INFLATABLE SEALS**  
VIEWON OURWEBSITE  
<https://www.westernsealtech.com/knowledge-center/>

- 

**FOOD + PHARMACEUTICAL TUBINGS & HOSES**  
VIEWON OURWEBSITE  
<https://www.westernsealtech.com/knowledge-center/>

- 

**RAIL AND MASS TRANSIT**  
VIEWON OURWEBSITE  
<https://www.westernsealtech.com/knowledge-center/>

- 

**RUBBER EXTRUSIONS**  
VIEW ON OUR WEBSITE  
<https://www.westernsealtech.com/rubber-extrusions/>





### **Head Office**

Office No. 1012, 72 Corp, Sakinaka,  
Near Metro Station, Andheri (E), Mumbai  
400072, MH, India.

### **Sales Office (USA)**

3524, Silverside Road, Suite 35B,  
Wilmington, Delaware 19810-4929.

### **Western Rubbers Europe B.V.**

Smederijstraat 2, 4814 DB Breda,  
Netherlands

### **Manufacturing Unit 1 & 2**

Plot No, 21 And Plot No. 24, Survey No.  
1994 and 1997, At Daheri, Umbergaon,  
Valsad, Gujarat 396171, India

Plot no. 28, Survey No. 39, At Daheri,  
Umbergaon, Valsad, Gujarat 396170,  
India



[www.westernsealtech.com](http://www.westernsealtech.com)



[sales@westernsealtech.com](mailto:sales@westernsealtech.com)



+91 9130026591 | +91 9130026592



Western Sealtech