



# RUBBER EXTRUSIONS

Product  
Brochure





LATE MR. KANUBHAI C. SHAH  
*Founder*

---

**SUCCESS** is certain  
when you move from  
**ONE FAILURE** to another,  
without losing **ENTHUSIASM**

# CONTENTS

---

Page No.

---

## COMPANY OVERVIEW

- 01** About us
- 02** Our Vision and Mission
- 03** Our Values
- 04** Why Choose Western Sealtech

## OUR PRODUCTS

- 05** Our Manufacturing Expertise
  - 08** Spliced and Vulcanised Gaskets
  - 09** Extrusion Profiles
  - 15** Application of Rubber Extrusions
  - 19** Certifications & Compliances
  - 21** Material Comparison Chart
  - 23** Our Clientele
  - 24** Other Catalogues
-



# ABOUT US

Established in 1972, Western Sealtech specializes in manufacturing all types of extruded rubber seals. With over 50 years of experience, our seals are made up of elastomers having specially developed in-house formulations, which make our seals not only appealing in aesthetics but also long lasting in extreme environments. We take pride in extruding intricate shapes and designs, which have otherwise been difficult to manufacture. We guide and work with our clients to meet their stringent parameters on compression set, elongation, hardness, density and other such physical as well as chemical properties which are required in their application.



# OUR VISION & MISSION

**Our Vision** is to be a global leader in rubber extrusion based sealing technologies

**Our Mission** is to fulfil our vision via unparalleled customer-centric approach



# OUR VALUES

## INTEGRITY

"Integrity is doing the right thing, even when no one is watching."  
-C.S Lewis

## COMMITMENT

"Commitment is what transforms a promise into a reality."  
-Abraham Lincoln

## PASSION

"The greatest feeling in the world is getting paid to do what you love."  
-Anonymous

## WHY CHOOSE WESTERN SEALTECH?



Over 50 years of experience



10 extrusion lines

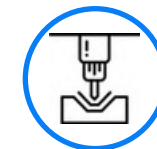

2500 extrusion dies



Extrusion with adhesive taping

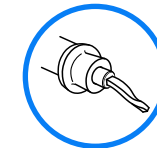

Profiles up to 5 inches in diameter can be extruded



In-house die making facility



## OUR MANUFACTURING EXPERTISE

---

Rubber Tubings

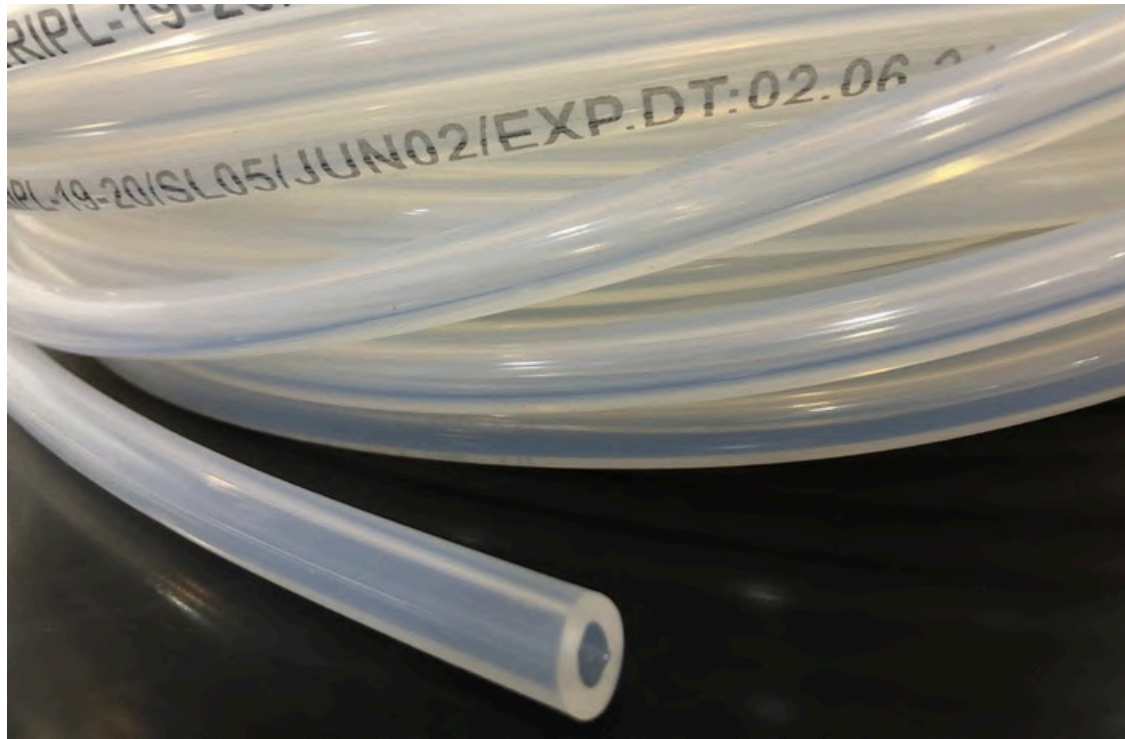

Rubber Strips



## OUR MANUFACTURING EXPERTISE

---

Sponge Extrusions

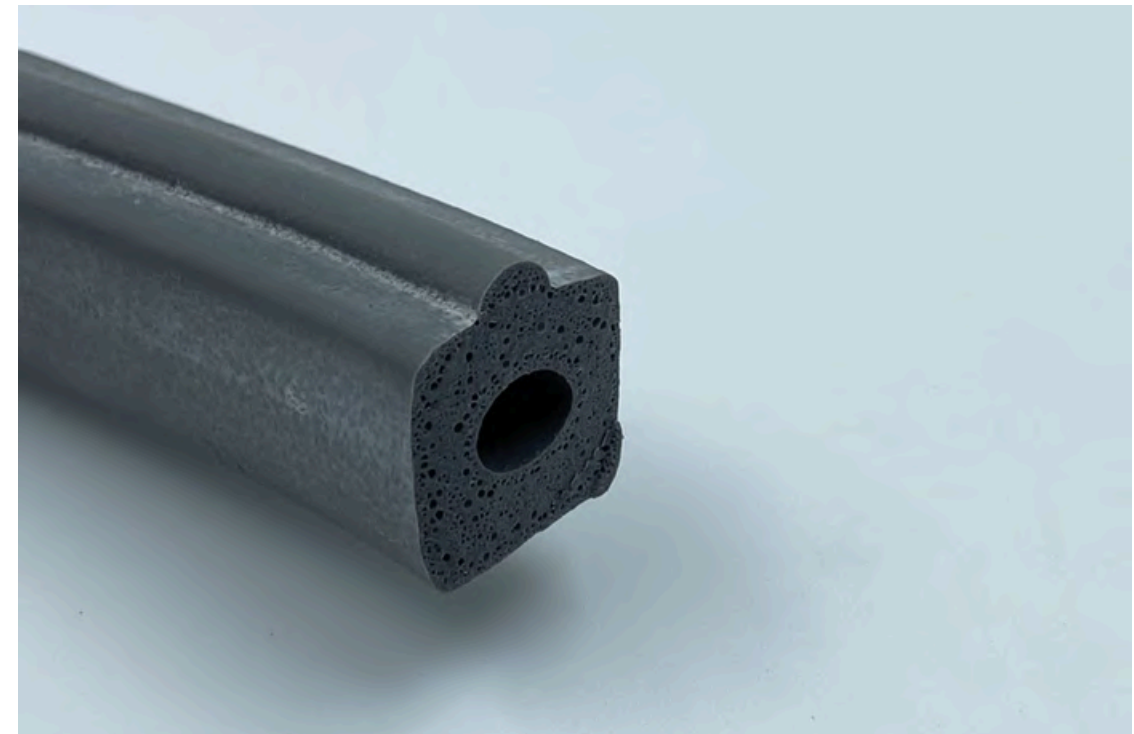

Custom Extrusions

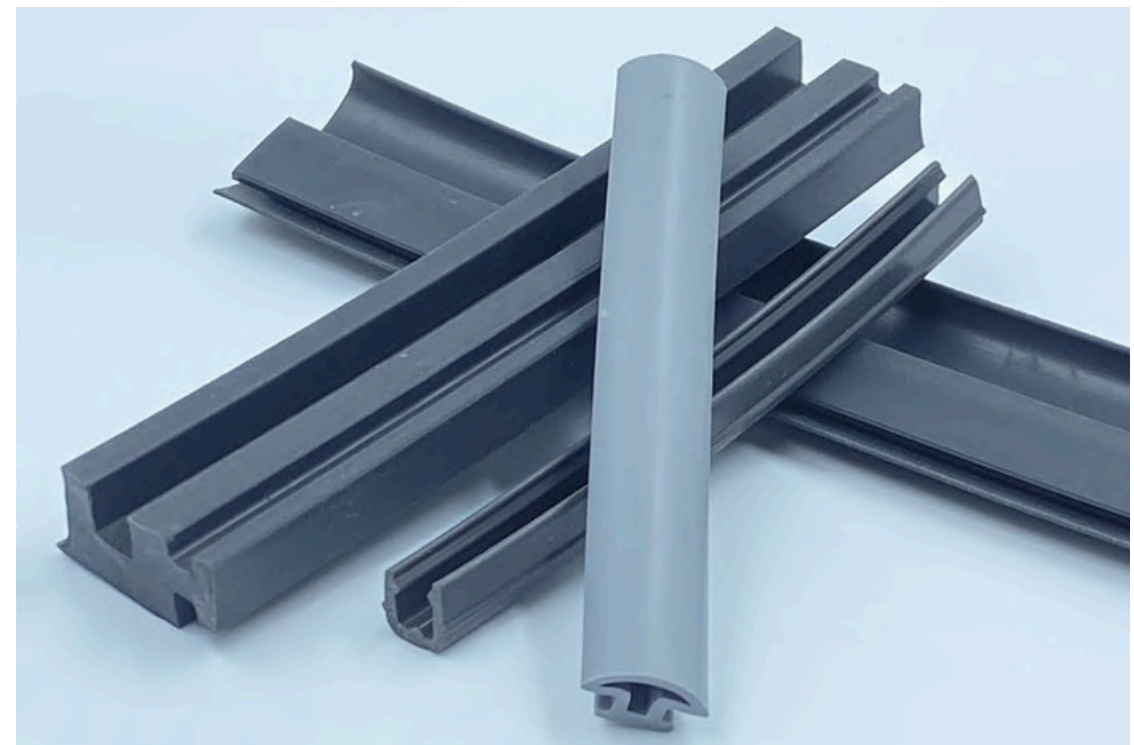

## OUR MANUFACTURING EXPERTISE

### Inflatable Seals

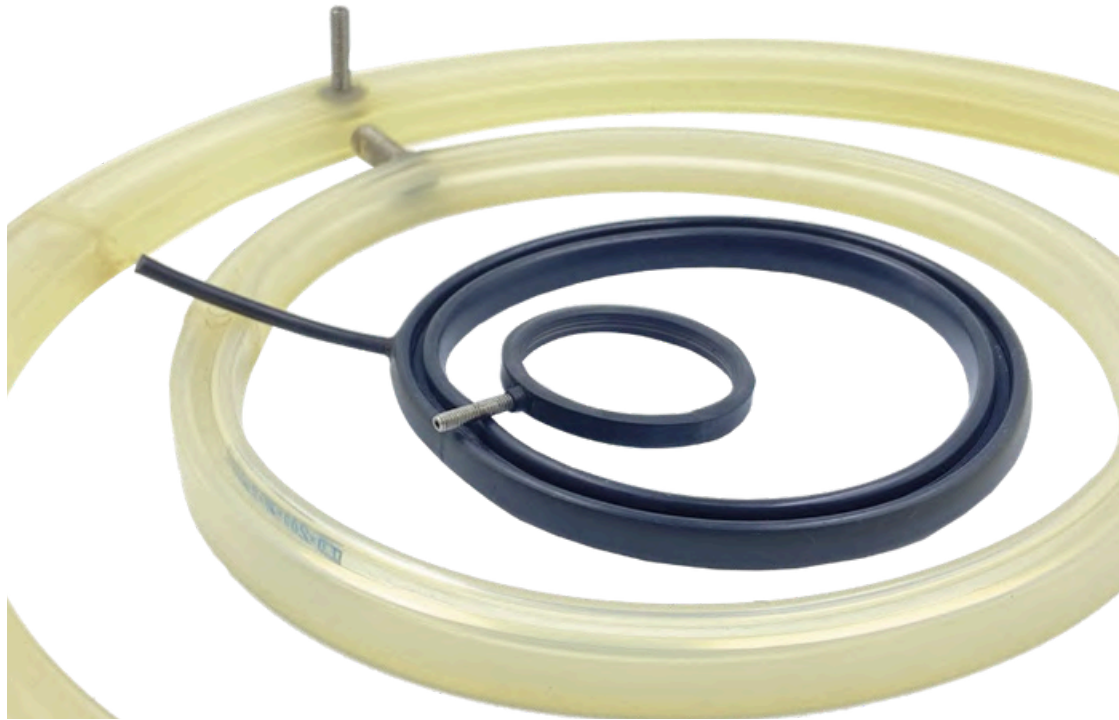

### Reinforced Hoses

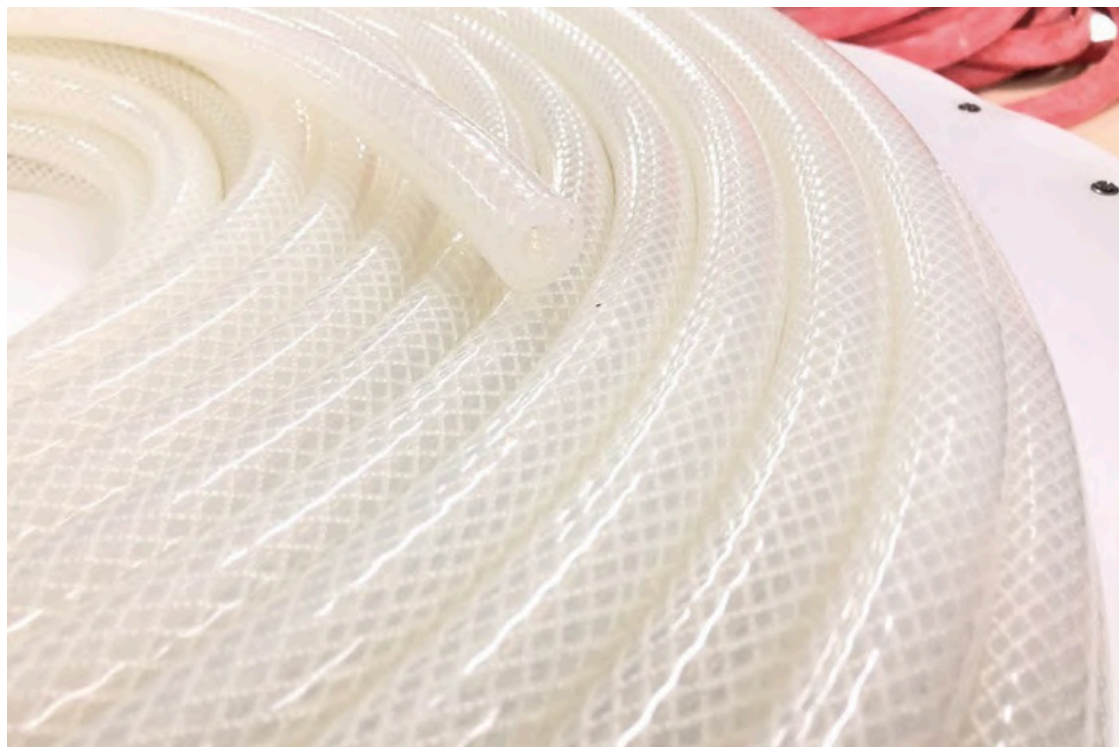

## SPLICED AND VULCANISED (JOINED) GASKETS

A very large number of gaskets at Western Sealtech are manufactured by **splicing and vulcanising** extruded elastomer profiles. The extruded profile is first **cut with precision** (splicing). The loose ends of this seal are then **bonded together** by applying uncured compound (the same as used in the extruded seal) at the point where the ends meet. This join is then **moulded at high temperatures** for a specified period of time to form a strong unbreakable bond. Western Sealtech is known for offering the best joins for gaskets since the **joints are compression moulded** rather than bonded using adhesives.



**DETAIL AT "X":** Vulcanized gasket for Clean Room Door



**DETAIL AT "Y":** Vulcanized silicone gasket, with the ability to withstand temperatures upto -80°C, for sealing freezer doors.

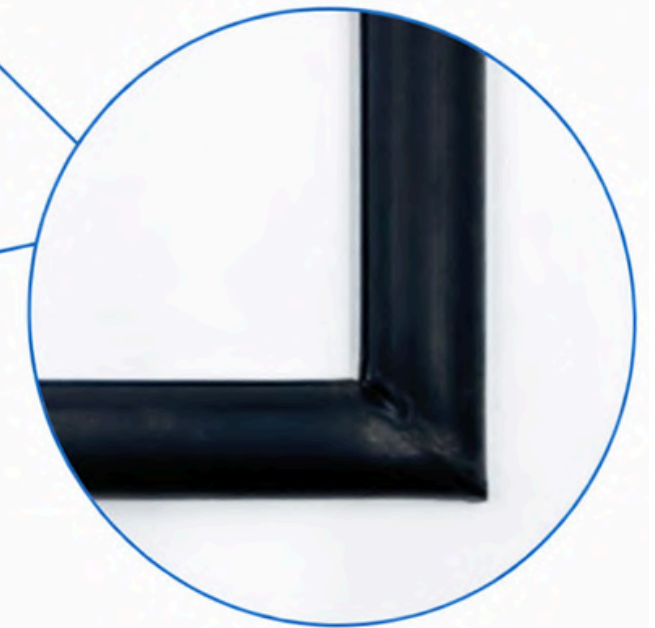

**ENLARGED VIEW OF VULCANIZED JOINT**



# EXTRUSION PROFILES

## P-TYPE

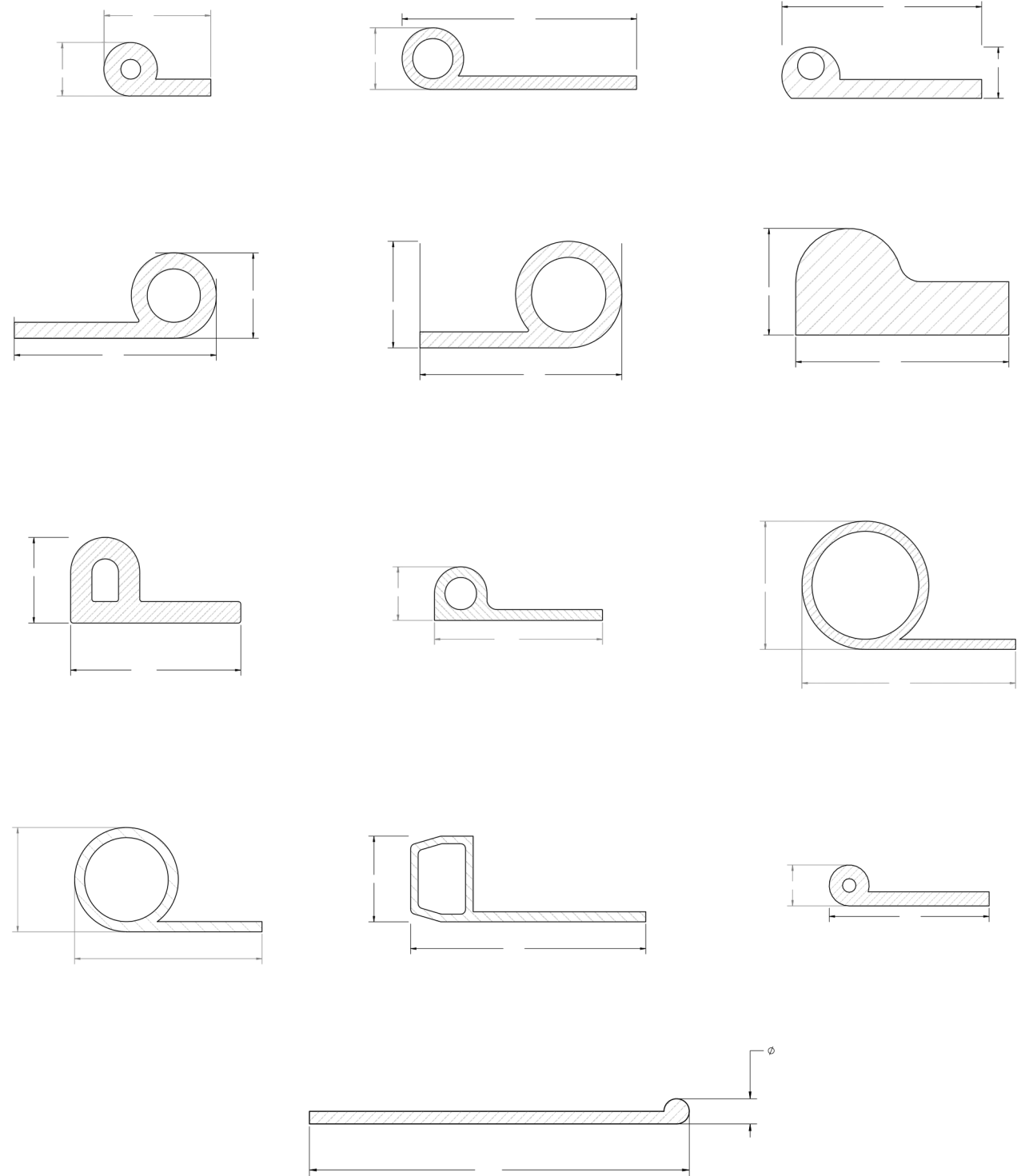

# EXTRUSION PROFILES

## E-TYPE

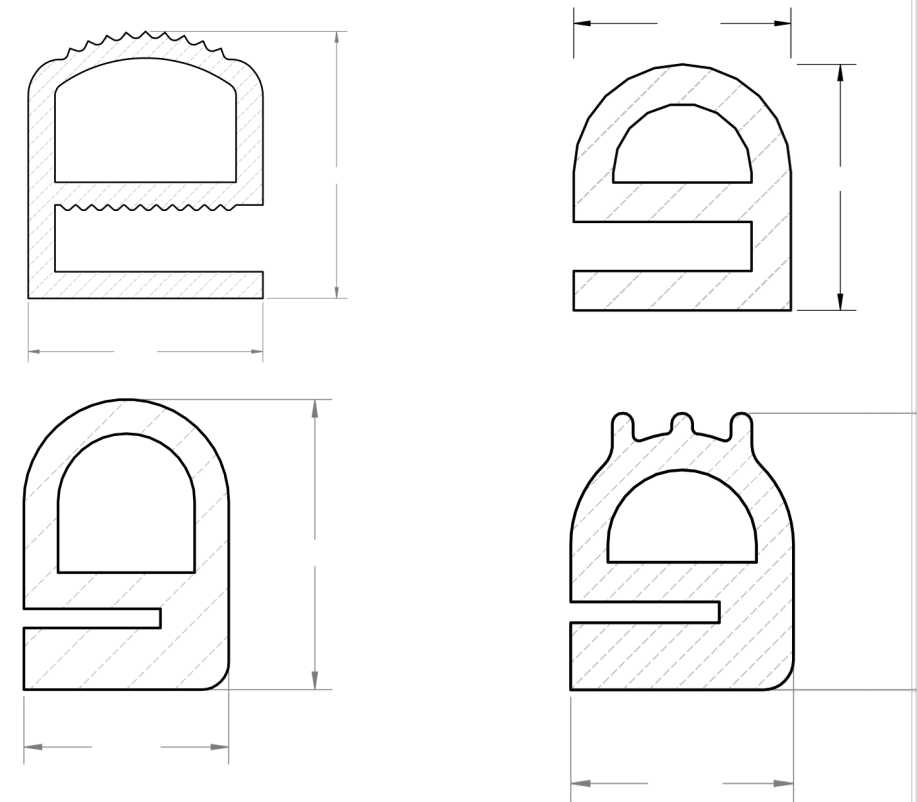

## H-TYPE

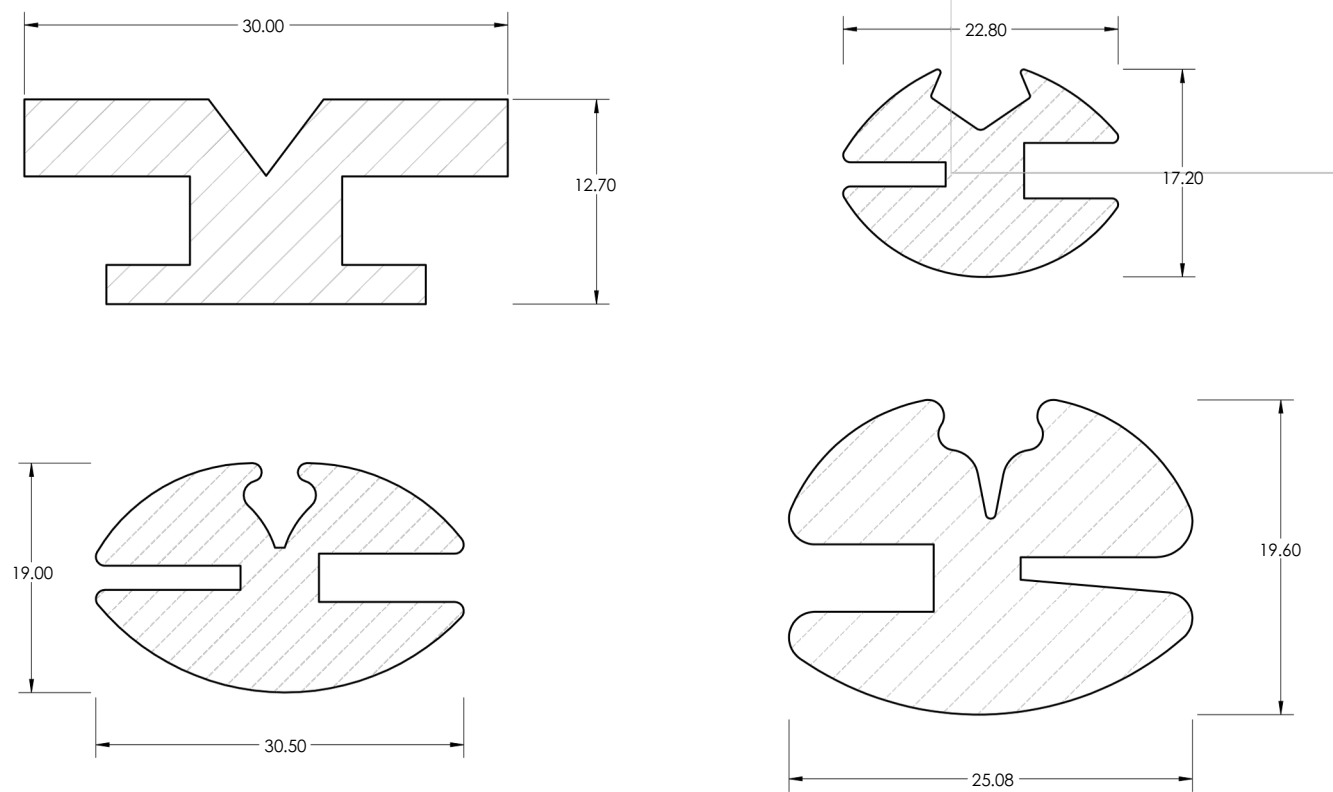

# EXTRUSION PROFILES

## SOLID TYPE

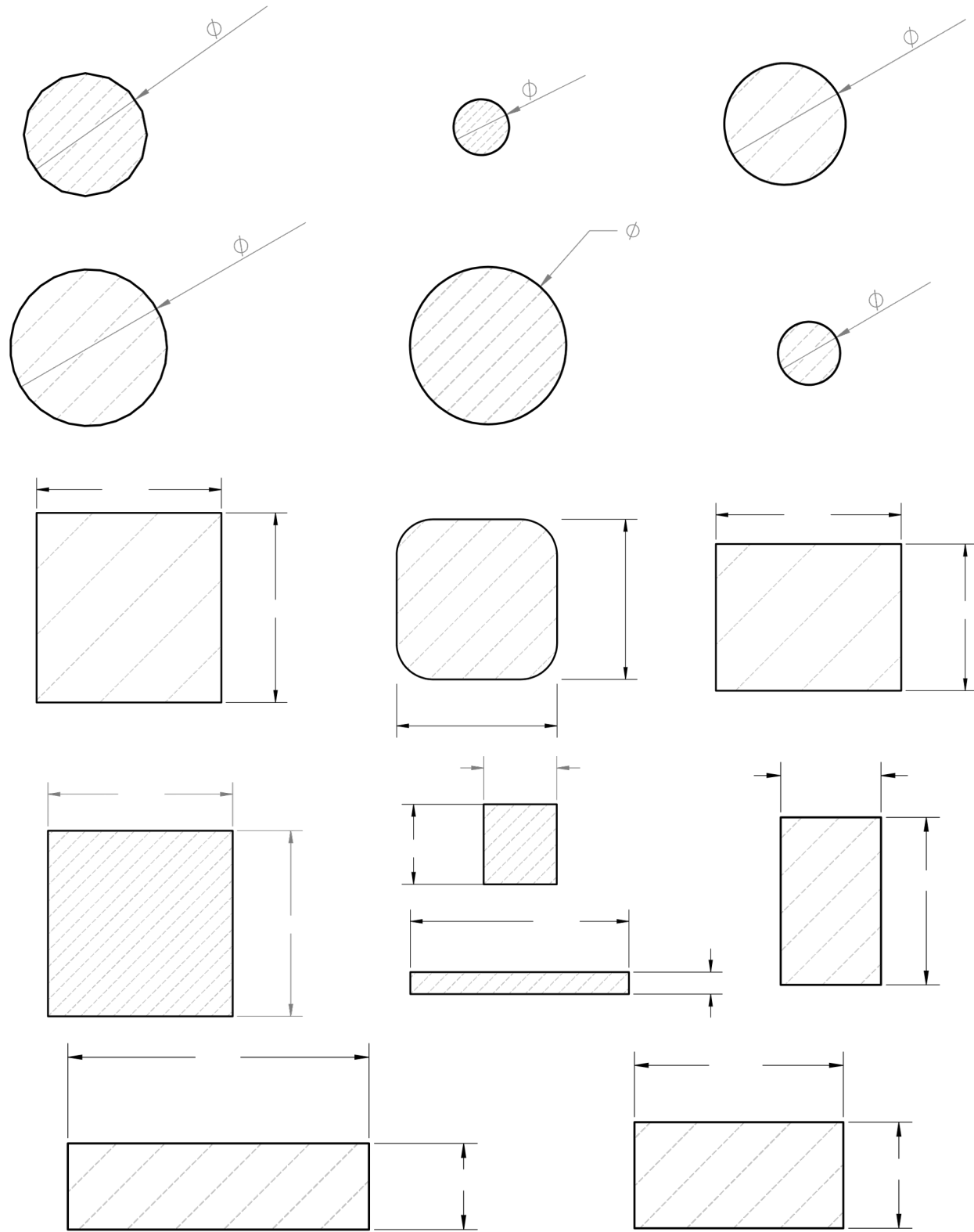

# EXTRUSION PROFILES

## MISCELLANEOUS

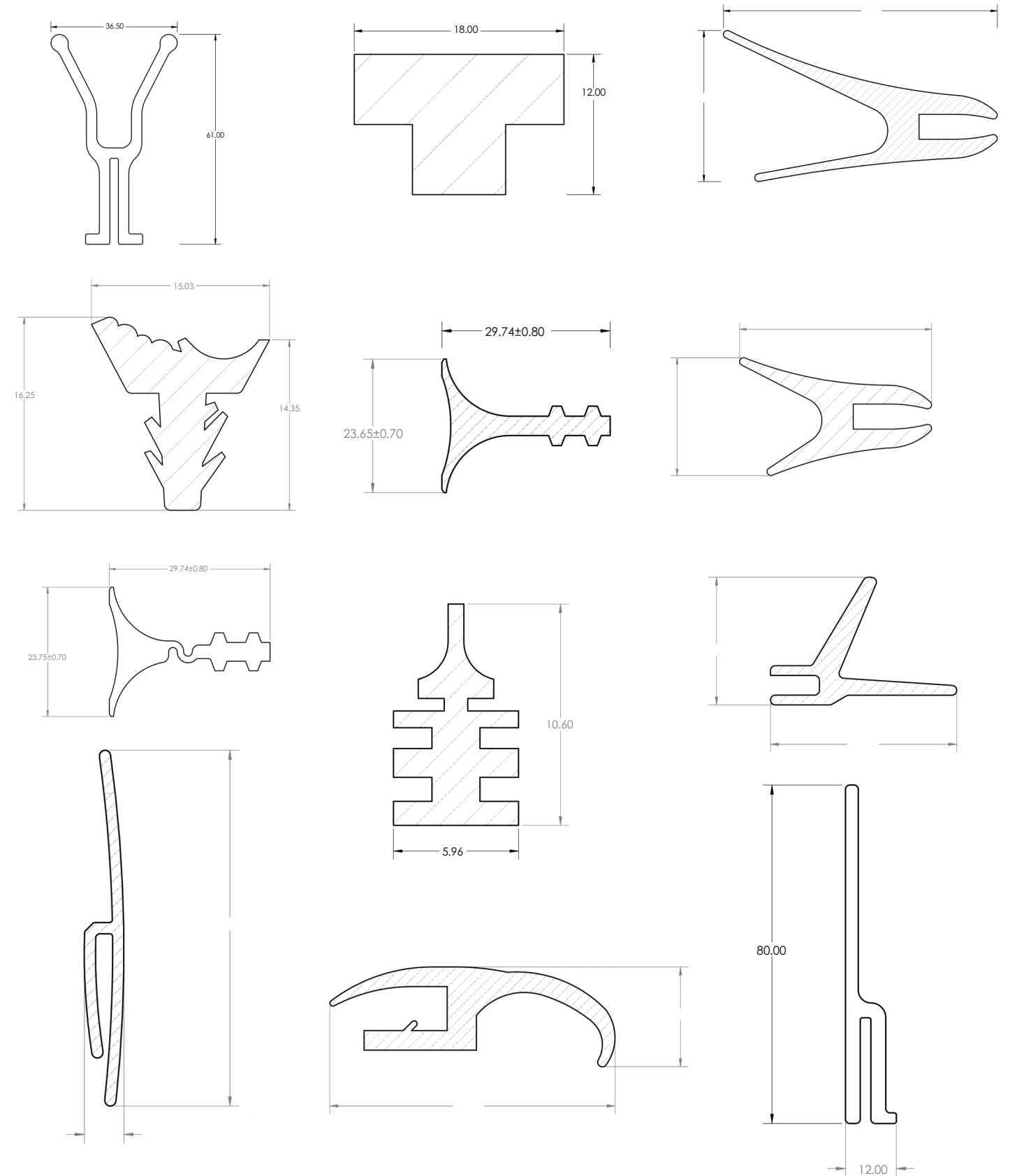

# APPLICATION OF RUBBER EXTRUSIONS

## Metro Doors



HL3 certified Rubber strips and sponge extrusions for sealing metro doors and windows\*

## Commercial Doors



Rubber extrusions for sealing commercial doors and windows

# APPLICATION OF RUBBER EXTRUSIONS

## Autoclave Doors

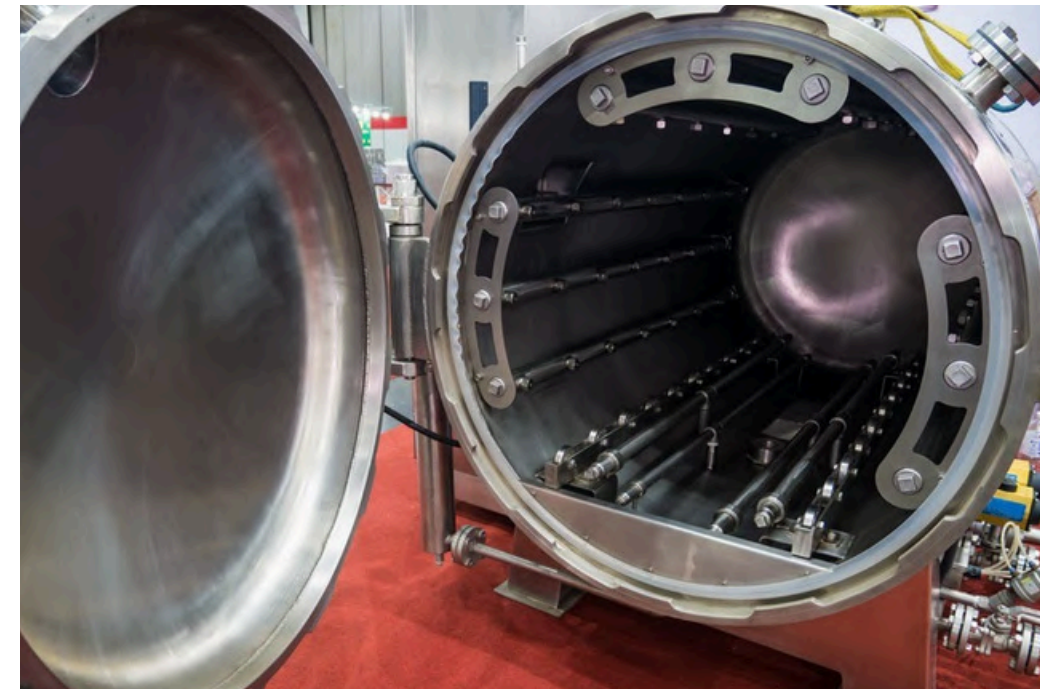

Extruded and joined gaskets for sealing autoclave sterilizers

## Bio Hazard Doors



Medical grade rubber extrusions for sealing bio hazard doors

# APPLICATION OF RUBBER EXTRUSIONS

## Hangar Doors



Weather resistant rubber extrusions for sealing hangar doors

## Hatch Doors

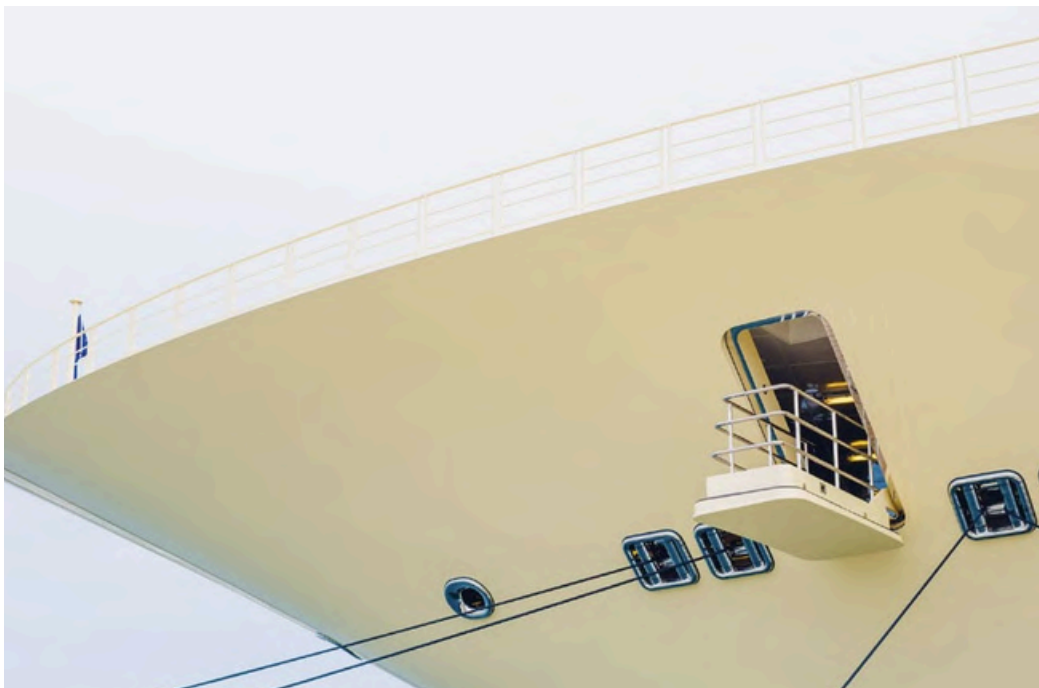

Rubber extrusions for sealing hatch doors

# APPLICATION OF RUBBER EXTRUSIONS

## Pharmaceutical Industry



Silicone tubings for filling lines

## Pharmaceutical Industry



Silicone/TPE tubings in peristaltic pumps

## CERTIFICATIONS & COMPLIANCES



“QUALITY ALWAYS COMES FIRST” has been the motto of Western Sealtech since its inception in 1972. At Western Sealtech we are committed to continuous improvement in our quality system. Our Quality Control team is bound by extremely stringent guidelines when it comes to making decisions for quality check and approval. The quality control process begins from the very moment a raw material enters our facility. In the compounding stage i.e., the stage when the elastomeric/polymeric raw material is mixed with other ingredients to develop suitable compounds which then go in for manufacturing, it becomes extremely crucial to ensure that the material being developed meets all the regulatory specification.

Western Sealtech can offer the following compliances/certification for its gaskets:

### FDA 21.CFR177.2600

The FDA indicates safety regulations for the use of “Rubber articles in producing, manufacturing, packing, processing, preparing, treating, packaging, transporting, or holding food”

The Code of Federal Regulations (CFR) is a codification of the general and permanent rules published in the Federal Register by the Executive departments and agencies of the Federal Government. Title 21 of the CFR is reserved for rules of the Food and Drug Administration.

**EUROPEAN PHARMACOPEIA** The European Pharmacopeia regulates quality standards for ALL medicinal products in its member states, i.e. raw material, preparations, dosage forms, containers, or any material that might come in contact with the medicinal ingredients in any stage

**REACH COMPLIANT** REACH deals with Registration, Evaluation, Authorization, and restriction of certain Chemicals used in products. The primary focus of this European Directive is to focus on substances which may potentially impact human health and/or the environment. These substances are commonly called Substances of Very High Concern (SVHC).

## CERTIFICATIONS & COMPLIANCES

**RoHS COMPLIANT** RoHS i.e. Restriction of the Use of certain Hazardous Substances in Electrical and Electronic Equipment (RoHS), is a product level compliance based on the European Union's Directive 2002/95/EC. The Products compliant with this directive do not exceed the allowable amounts of certain restricted materials, as listed in the directive.

<https://www.accessdata.fda.gov/scripts/cdrh/cfdocs/cfcfr/cfrsearch.cfm?fr=177.2600>

### TSE AND BSE FREE CERTIFICATION

Pharmaceutical products having raw materials derived from animal sources have a risk of TSE i.e. Transmissible Spongiform Encephalopathy. In the Form of pharmaceutical dosages, this disease could transmit in humans from cattle infected with BSE i.e. Bovine Spongiform Encephalopathy.

<https://www.accessdata.fda.gov/scripts/cdrh/cfdocs/cfcfr/cfrsearch.cfm?fr=177.2600>

### EXTRACTABLES AND LEACHABLES FREE CERTIFICATION

Extractables and Leachables (E/L) studies are critical to the identification and quantification of harmful leach-able impurities which could migrate from pharmaceutical container closure systems, process equipment and packaging to contaminate pharmaceutical products.

<https://www.intertek.com/pharmaceutical/analysis/extractables-leachables/>

**USP CLASS VI** The U.S. Pharmacopeial Convention (USP) is a non-profit organization, with a purpose of creating standards for medications, food ingredients, dietary supplements and healthcare technologies. The USP publishes bio compatibility protocols for the plastics and polymers used in medical devices or surgical equipment, that may come in contact with human tissue.

USP Class VI provides guidelines for testing and certification of a material to be used within a medical device.

<https://www.intertek.com/pharmaceutical/analysis/extractables-leachables/>

### BPA FREE CERTIFICATION

BPA stands for Bisphenol A and can be found in many plastic items. The problem with BPA in packaging is that the chemical can percolate into the food or liquid it contains. All packaging done by Western Sealtech is certified as BPA free.

<https://www.intertek.com/pharmaceutical/analysis/extractables-leachables/>

### HL3 CERTIFIED

EN 45545, a mandatory requirement in Europe for all materials used in the manufacture of rail vehicles. EN45545 is a European railway standard that was published in 2013 in order to harmonize the different train management systems including fire and smoke standards. It aims to protect passengers and staff against fire on board railway vehicles. All materials used in the manufacture of railway vehicles must follow the EN45 545 standard to achieve the highest possible level of safety in case of fire.

EN 45545 applies to manufacturers of rail vehicles, including high-speed trains, regional trains, streetcars, subways and double-decker trains.

<https://www.samaro.fr/en>

### TUV SUD ISO 9001

TÜV SÜD issues the ISO 9001 certification and certification mark. TÜV SÜD certification mark is globally recognized and synonymous with quality and safety. It reviews the compliance of the company activities to ISO 9001 requirements and company records.

<https://www.tuvsud.com/en-in/services/auditing-and-system-certification/iso-9001>



## OUR CLIENTELE



## OTHER CATALOGUES



### COMPANY PROFILE

VIEWONOURWEBSITE

<https://www.westernsealtech.com/knowledge-center/>



### INFLATABLE SEALS

VIEWONOURWEBSITE

<https://www.westernsealtech.com/knowledge-center/>



### RUBBER & PTFE DIAPHRAGMS

VIEWONOURWEBSITE

<https://www.westernsealtech.com/knowledge-center/>



### FOOD + PHARMACEUTICAL TUBINGS & HOSES

VIEWONOURWEBSITE

<https://www.westernsealtech.com/knowledge-center/>



### RAIL AND MASS TRANSIT

VIEWONOURWEBSITE

<https://www.westernsealtech.com/knowledge-center/>





## Head Office

Office No. 1012, 72 Corp, Sakinaka,  
Near Metro Station, Andheri (E), Mumbai  
400072, MH, India.

## Sales Office (USA)

3524, Silverside Road, Suite 35B,  
Wilmington, Delaware 19810-4929.

## Western Rubbers Europe B.V.

Smederijstraat 2, 4814 DB Breda,  
Netherlands

## Manufacturing Unit 1 & 2

Plot No, 21 And Plot No. 24, Survey No.  
1994 and 1997, At Daheri, Umbergaon,  
Valsad, Gujarat 396171, India

Plot no. 28, Survey No. 39, At Daheri,  
Umbergaon, Valsad, Gujarat 396170,  
India



[www.westernsealtech.com](http://www.westernsealtech.com)



[sales@westernsealtech.com](mailto:sales@westernsealtech.com)



+91 9130026591 | +91 9130026592



Western Sealtech