

## **AEROTHERMODYNAMIC REENTRY FLIGHT EXPERIMENTS EXPERT**

J.Muylaert<sup>(1)</sup>, L.Walpot<sup>(2)</sup>, H.Ottens<sup>(2)</sup>, F.Cipollini<sup>(1)</sup>

<sup>(1)</sup>ESA-ESTEC, Keplerlaan 1 – P.O.Box 299 – 2200 AG Noordwijk ZH – The Netherlands,  
*Jean-Marie.Muylaert@esa.int*

<sup>(2)</sup>ATOS ORIGIN, Haagse Schouwweg 6G – 2332 KG Leiden – The Netherlands,  
*Louis.Walpot@atosorigin.com*

### ABSTRACT

The paper addresses the ESA in flight Aerothermodynamic (ATD) research programme referred to as **EXPERT**: the **E**uropean **EX**perimental **R**e-entry **T**estbed.

The objective of this in-flight research programme is to design and instrument generic configurations, for in-flight measurements of critical ATD phenomena using state-of-the-art instrumentation. Hypersonic flight data are required for improved understanding of the following critical ATD phenomena :

- Transition,
- Catalicity and oxidation,
- Real gas effects on shock wave boundary layer interactions,
- Microaerothermodynamics,
- Blackout.

Special attention is given to the design of the flight measurement sensors themselves, their integration into the TPS as well as to the measurement of the free stream parameters during re-entry using an Air Data System.

In addition to the procurement of “good enough” hypersonic data, the EXPERT programme includes also windtunnel testing and numerical simulations to complete the above listed critical ATD validation process including windtunnel to flight extrapolation activities. The present paper will report on: selection of reference mission profiles offered by Volna launcher, geometrical design optimisation of the configuration and elaborate on the embarked payloads for the provision of the hypersonic data associated with the above listed critical ATD phenomena.

# Report Documentation Page

Form Approved  
OMB No. 0704-0188

Public reporting burden for the collection of information is estimated to average 1 hour per response, including the time for reviewing instructions, searching existing data sources, gathering and maintaining the data needed, and completing and reviewing the collection of information. Send comments regarding this burden estimate or any other aspect of this collection of information, including suggestions for reducing this burden, to Washington Headquarters Services, Directorate for Information Operations and Reports, 1215 Jefferson Davis Highway, Suite 1204, Arlington VA 22202-4302. Respondents should be aware that notwithstanding any other provision of law, no person shall be subject to a penalty for failing to comply with a collection of information if it does not display a currently valid OMB control number.

1. REPORT DATE <b>01 JUN 2007</b>		2. REPORT TYPE <b>N/A</b>		3. DATES COVERED <b>-</b>	
4. TITLE AND SUBTITLE <b>Aerothermodynamic Reentry Flight Experiments Expert</b>				5a. CONTRACT NUMBER	
				5b. GRANT NUMBER	
				5c. PROGRAM ELEMENT NUMBER	
6. AUTHOR(S)				5d. PROJECT NUMBER	
				5e. TASK NUMBER	
				5f. WORK UNIT NUMBER	
7. PERFORMING ORGANIZATION NAME(S) AND ADDRESS(ES) <b>ESA-ESTEC, Keplerlaan 1 P.O.Box 299 2200 AG Noordwijk ZH The Netherlands</b>				8. PERFORMING ORGANIZATION REPORT NUMBER	
9. SPONSORING/MONITORING AGENCY NAME(S) AND ADDRESS(ES)				10. SPONSOR/MONITOR'S ACRONYM(S)	
				11. SPONSOR/MONITOR'S REPORT NUMBER(S)	
12. DISTRIBUTION/AVAILABILITY STATEMENT <b>Approved for public release, distribution unlimited</b>					
13. SUPPLEMENTARY NOTES <b>See also ADM002057., The original document contains color images.</b>					
14. ABSTRACT					
15. SUBJECT TERMS					
16. SECURITY CLASSIFICATION OF:			17. LIMITATION OF ABSTRACT	18. NUMBER OF PAGES	19a. NAME OF RESPONSIBLE PERSON
a. REPORT <b>unclassified</b>	b. ABSTRACT <b>unclassified</b>	c. THIS PAGE <b>unclassified</b>			

## RATIONALE FOR IN FLIGHT RESEARCH

The aerodynamic knowhow needed to design and safely fly future hypersonic space vehicles is generally obtained by ground-based experimental simulation, computational predictions and ground-to-flight extrapolation methodologies. However, unless these tools have been validated by comparisons to relevant flight data, they may lack the confidence needed to ensure optimal engineering margins. The best approach for improving confidence in ATD design tools, both for the computational and for the ground-based experimental design tools, is to validate those tools and design approaches against *flight experiments*. Even though such a strategy or approach appears desirable, it is often encumbered with *serious deficiencies* such as poor measurement accuracy and resolution, flow contamination, poor free stream characterization, limited single point isolated measurements in addition to the costs and risks associated with achieving a successful flight. Moreover, there have been no recent results from hypersonic flight programs such as X-vehicles in Europe or in the U. S., whereas, there have been a significant number of computational and experimental tools developed. Consequently, there is a scarcity of hypersonic flight data that can serve as a *benchmark* for validating computational tools and design approaches, particularly for some of the more challenging hypersonic problems.

The EXPERT flight test programme focuses on generic configurations designed in such a way as to enhance the ATD phenomena of interest enabling measurements to be made with improved accuracy and spatial resolution.

**It is stressed here that EXPERT is not a demonstrator for space transportation system or subsystem vehicle design and qualification but rather a testbed provider of hypersonic data for use in an ATD design tool validation process<sup>1</sup>, see**

### **1. FULL SCALE 1 FLIGHT :**

- e.g. - SHUTTLE, BOURANE, APOLLO, SHENZHOU, ARIANE 5, HUYGENS
- HOPE, HERMES, OSP
- HERCULES, SOCRATES

### **2. EXPERIMENTAL DEMONSTRATOR VEHICLES :**

- e.g. - X23, X24, X38, AS201, AS202, APOLLO 4,6 ARD,
- BOR4 for TPS ; BOR5 for GNC;
- OREX, HYFLEX for TPS ; ALFEX for GNC
- MAIA, PHOENIX 1 and 2 for GNC
- FLPP IXV ( PRE-X – USV )

### **3. IN FLIGHT RESEARCH VEHICLES**

- e.g. - SHARP B1, B2 FLIGHTS, HYSHOT, X43,
- IRDT, PAET, RAMC, FIRE
- MIRKA, EXPRESS, SHEFEX, SFYFE
- EXPERT

Figure 1.

**1. FULL SCALE 1 FLIGHT :**

- e.g. - SHUTTLE, BOURANE, APOLLO, SHENZHOU, ARIANE 5, HUYGENS
- HOPE, HERMES, OSP
- HERCULES, SOCRATES

**2. EXPERIMENTAL DEMONSTRATOR VEHICLES :**

- e.g. - X23, X24, X38, AS201, AS202, APOLLO 4,6 ARD,
- BOR4 for TPS ; BOR5 for GNC;
- OREX, HYFLEX for TPS ; ALFEX for GNC
- MAIA, PHOENIX 1 and 2 for GNC
- FLPP IXV ( PRE-X – USV )

**3. IN FLIGHT RESEARCH VEHICLES**

- e.g. - SHARP B1, B2 FLIGHTS, HYSHOT, X43,
- IRDT, PAET, RAMC, FIRE
- MIRKA, EXPRESS, SHEFEX, SFYFE
- **EXPERT**

**Figure 1 In-flight experimentation strategy.**

The ATD tools consist of numerical as well as experimental, i.e. ground based facility-tools. The aim is to perform extensive pre- and post-flight analysis in the european hypersonic facilities such as S4, LTB, F4, HEG, Longshot, TH2 and to study flight extrapolation strategies on TPS gas/surface interaction in plasma facilities such as L3K, PWK, SIMOUN and SCIROCCO in combination with the use of the VKI plasmatron.

EXPERT will provide the improved ATD means for the upcoming ESA Launcher and Reentry programs.

Below, the objectives and the design approaches are outlined compatibly with the constraints in mass, volume and trajectories imposed by the VOLNA launcher.

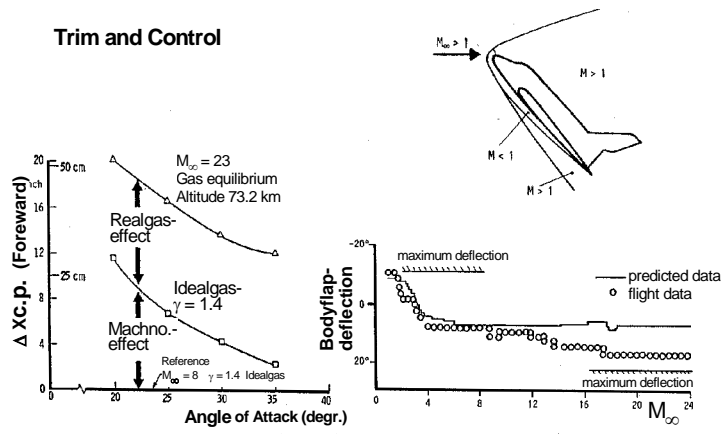
LESSONS LEARNED FROM THE PAST FLIGHT EXPERIMENTS

Below you will find some major lessons learned from flight test programs and a list of major critical phenomena where modeling needs to be improved as experienced in past and ongoing space vehicle design activities.

Figure 2 addresses the major lessons learned from the Orbiter space shuttle first flight.

Pitching moment anomaly : an addition of 8 degrees body flap action was required to trim the vehicle at hypersonic speed corresponding to the maximum allowable body flap range.

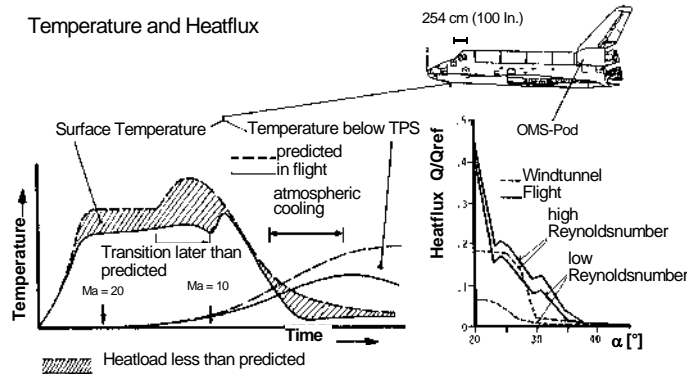
Note that elevon action could have largely compensated for this additional pitching moment.



Ref.: G. Laruelle/T. Bonnefond/P. Sacher, Flight Testing for Hypersonic Speed An European view, AGARD CP 600, C31-1, 1997 (Paris)

**Figure 2 Shuttle pitching moment anomaly.**

Figure 3 shows the conservative approach, which was taken for the design of the TPS by assuming transition to take place around Mach 15 as opposed to Mach 10 in flight.



Ref.: G. Laruelle/T. Bonnefond/P. Sacher, Flight Testing for Hypersonic Speed An European view, AGARD CP 600, C31-1, 1997 (Paris)

Figure 3 Shuttle heat flux overdimensioning.

Figure 4 and Figure 5 show some of the ARD post-flight rebuilding results. The need for improved instrumentation integration as well as the knowledge of the free stream using air data system was stressed. In general the agreement with flight was satisfactory. It must be stressed that the primary objective of the ARD was to demonstrate mastering of complete vehicle design approaches including all aspects of flight: launch, separation, de-orbit, re-entry parachute system and recovery. It is typical class 1 vehicle and therefore not designed to get data useful for code validation.

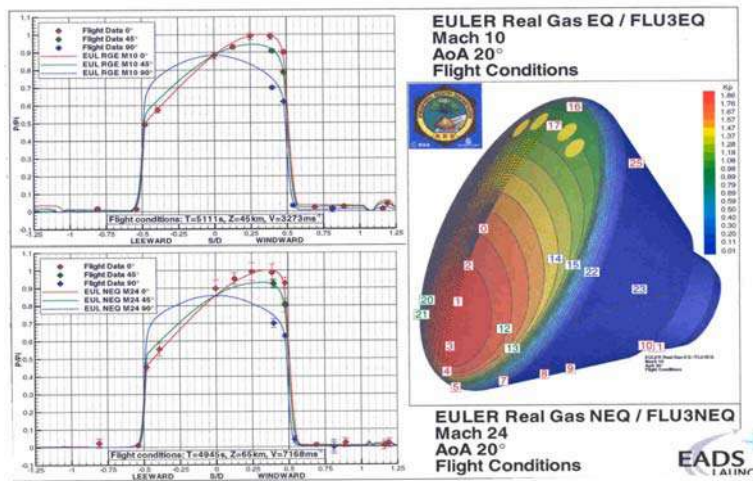
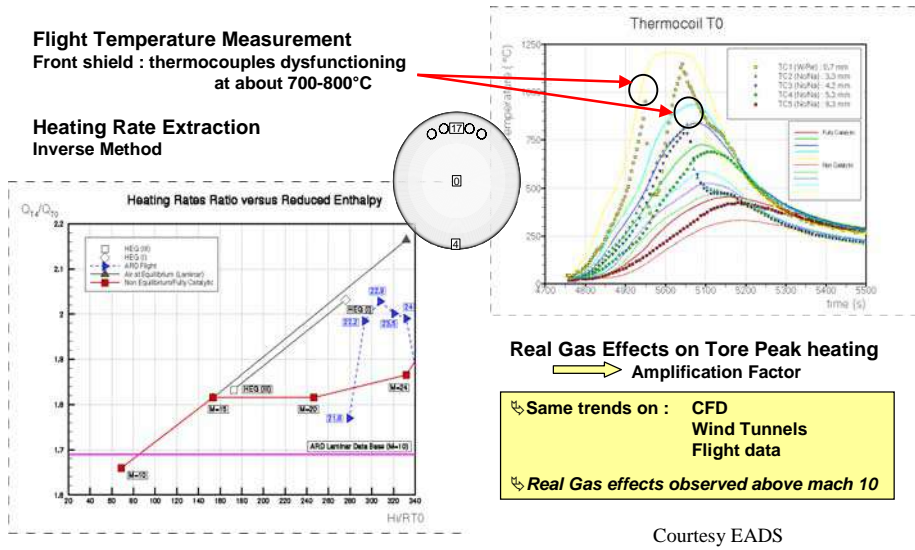
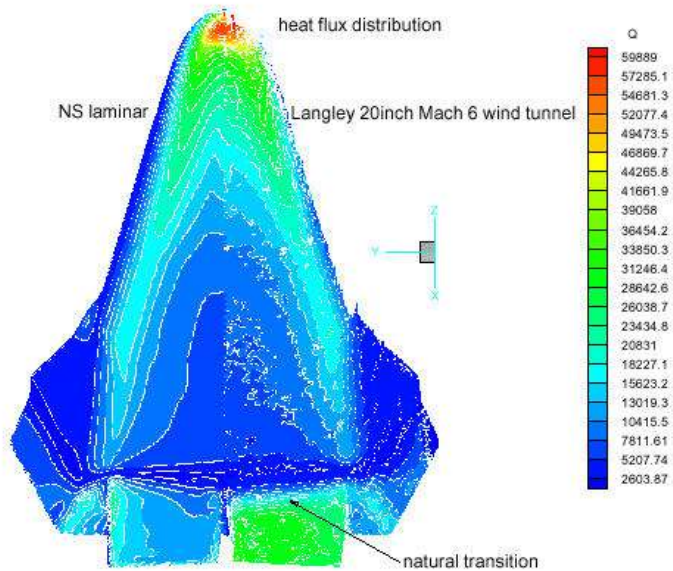


Figure 4 ARD pressure rebuilding activities.



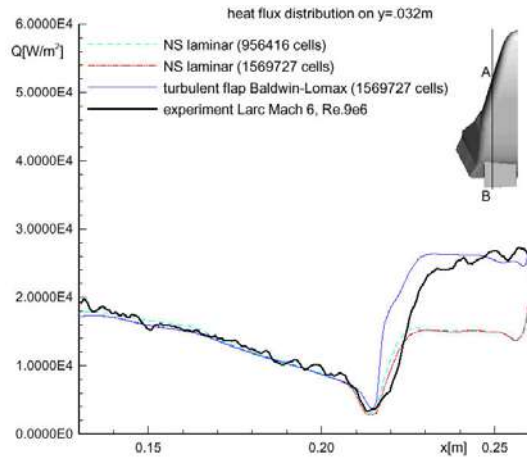
**Figure 5 Post-flight analysis of real gas effects on ARD.**

Figure 6 and Figure 7 address the issues around flap heating and flap efficiency. Data for improved modeling of shear layer transition are urgently needed.



**Figure 6 X-38 heat flux distribution at Mach 6.**

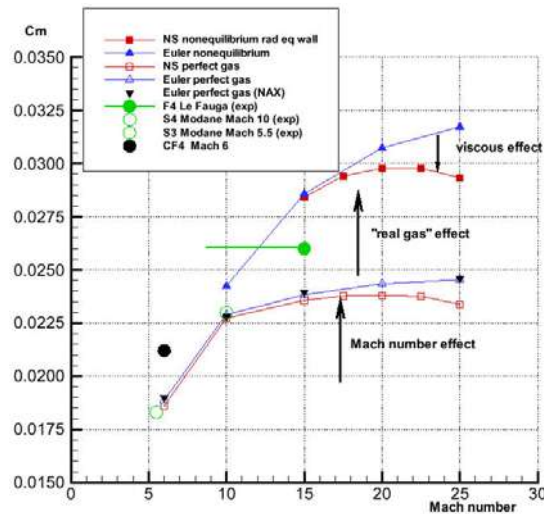
Unsteady pressure and heat flux data in windtunnel and flight conditions are required to validate new approaches such as DNS, LES, DES or new advanced RANS techniques.



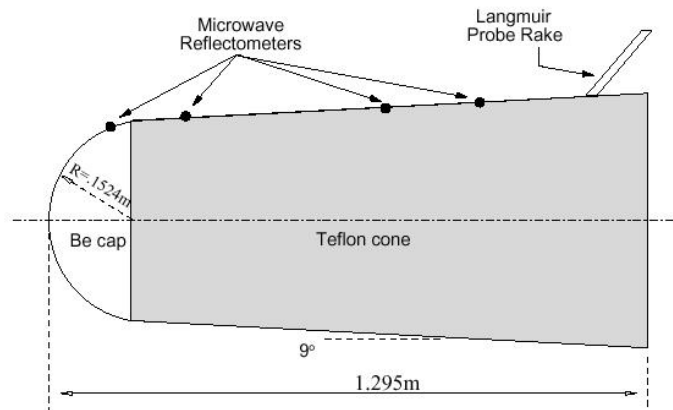
**Figure 7 X-38 flap heating at Mach 6.**

Figure 8 shows the contribution of compressibility, real gas, viscous interaction effects on pitching moment and a comparison with experiments in the Mach 6 CF4 LARC facility and in the ONERA hot shot F4. Mach number independence principle for this blunt configuration does clearly not hold anymore.

The data obtained in F4 and LARC CF4 Mach 6 are to be used for in situ facility code validation as they do not represent flight. Flight extrapolation needs to be done using CFD.

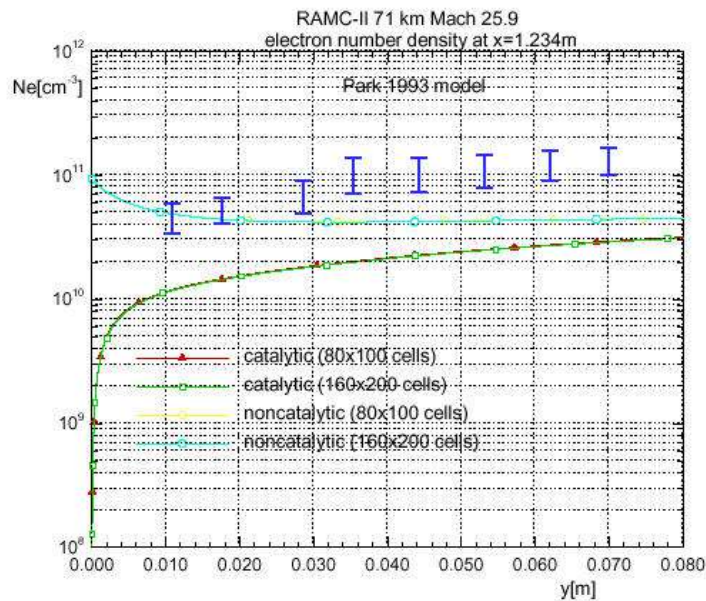


**Figure 8 X-38 pitching moment build up.**



**Figure 9 Langmuir probe/RAM C flight test.**

Figure 9, Figure 10 and Figure 11 summarize some of the RAM C flight rebuilding activities. Dunn and Kang model seems to fit better with the electron density number measurements than Park. Complementary data measuring vibrational levels, species concentrations are required to complete the database.



**Figure 10 RAM C flight rebuilding with PARK model.**

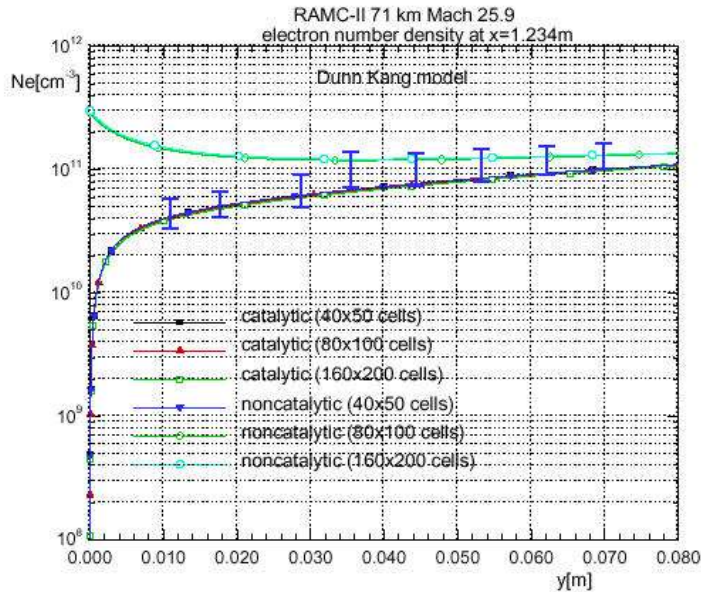


Figure 11 RAM C flight rebuilding with Dunn-Kang model.

Finally, Figure 12 and Figure 13 describe some major chemical processes for catalysis on silica surfaces.

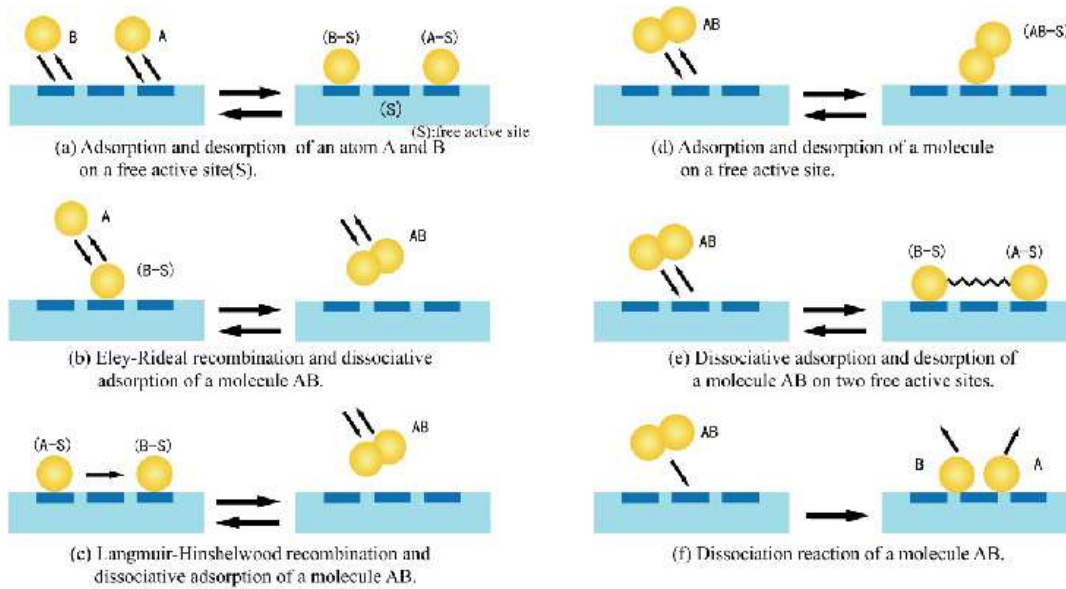
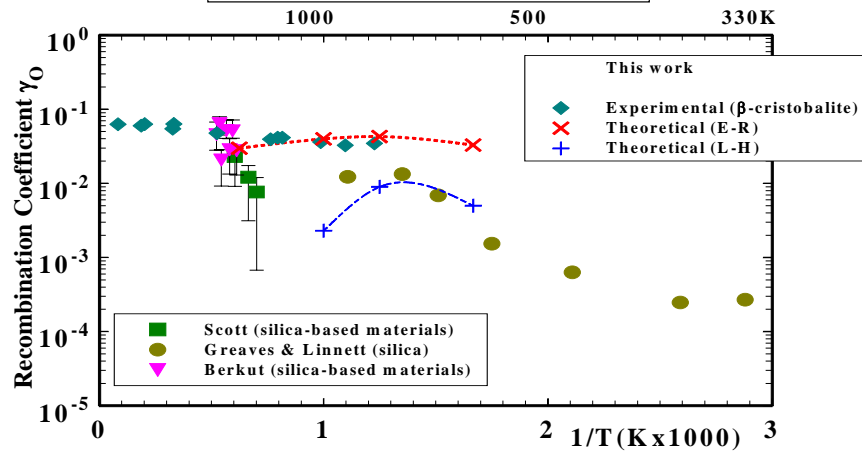


Figure 12 Chemical Processes in Heterogenous Catalysis on Surface

Different recombination mechanisms occur depending on the wall temperature. Data in ground based facilities, plasmatron (VKI), but also in laboratories such as in the solar furnace (Odeillo) as well as in flight would greatly advance catalysis modeling and is urgently needed.

## Physical Modelling (9/9)

Molecular Dynamics (2/2)  
Comparison between theoretical  
and experimental  $\gamma_O$



- E-R : weak surface temperature effect / L-H mechanism
- In this work : mainly E-R recombination (HT)
- 800 – 2000 K : E-R and 600 – 800 K : L-H

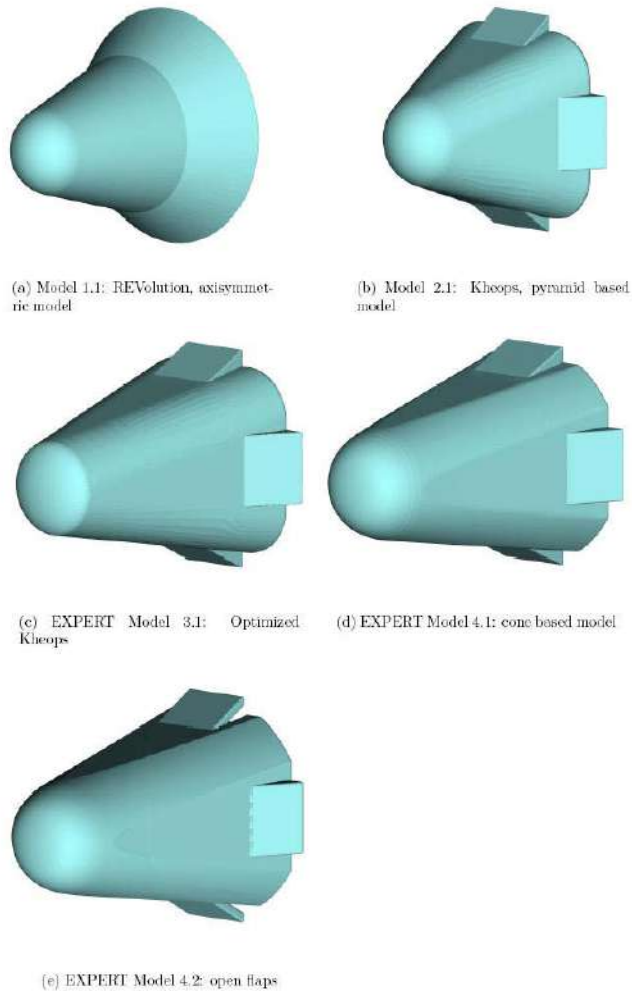
Figure 13  $\gamma_O$  Recombination coefficient modeling.

GEOMETRY OPTIMIZATION, TRAJECTORIES AND LAYOUT

EXPERT is an innovative low cost hypersonic flight program that, thanks to the flexibility of the Volna launcher, allows flying different trajectories corresponding to entry velocities varying from 5000 to 7000 m/s<sup>2</sup>.

A geometric optimisation and layout was performed taking into account the following constraints:

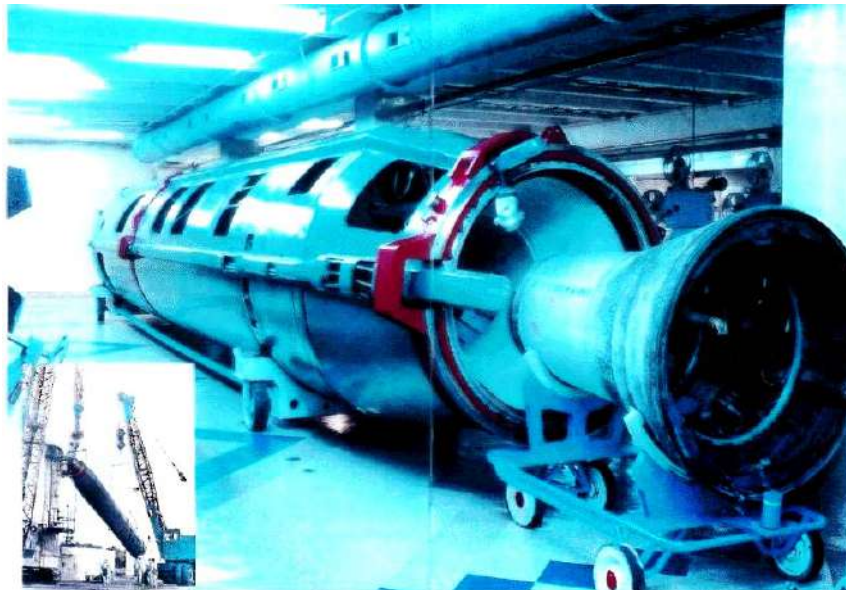
- Ballistic re-entries with vehicle mass and volume compatible with VOLNA 3<sup>rd</sup> stage
- Limitation of stagnation heat flux so as to avoid contamination of onboard flight measurements possibly caused by active oxidation of the C-SiC nose.
- Laminar attached flow over most portion of the flight to study:
  - different level of catalysis ( gas surface interactions );
  - roughness induced transition;
  - separated flow- shear layer induced transition in front of deflected flaps.



**Figure 14 Overview history EXPERT Model**

The optimised version of the EXPERT configuration, (in Figure 14 the entire evolution of the configuration is shown) is named KHEOPS; it is a blunt cone / flap – shape –configuration with a length of 1.60 m and a diameter of 1.23 m. The contour features an elliptic nose (local radius is 0.55 m) and a clothoide so as to keep the junction between nose and conical parts second order continue. The 12.5-degree conical leading edges feature axisymmetric flows enabling two-dimensional sensitivity computations. Two opposite flaps, at present fixed at 20 degrees, will be open (scoop) to study 3D micro-aerodynamic effects on corners, base flow recirculation and non convex reradiating wall effects. Two other opposite flaps may be closed to host sensitive instrumentation such as an IR camera and /or PYREX. Figure 15 shows the VOLNA launcher with the VOLAN vehicle as a payload used for in flight micro gravity experiments. EXPERT requires an RCS (Reaction and Control) system in order to keep the flight angle of attack as close as possible to the zero trimmed incidence. The feasibility study proposed a RCS system made of 6 N thrusters, active up to 80 km altitude.

Below this altitude only roll control is assumed and longitudinal stability should assure that incidence variations are below 0.5 degrees.



**Figure 15 Volna Launcher.**

AEROTHERMODYNAMIC ENVIRONMENT

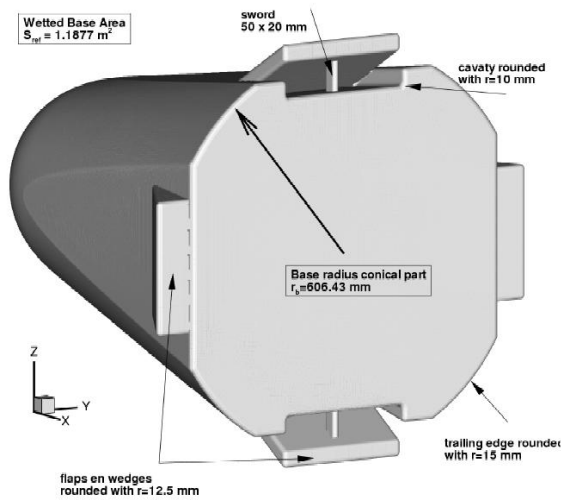


Figure 16 KHEOPS revision 4.2; Base view.

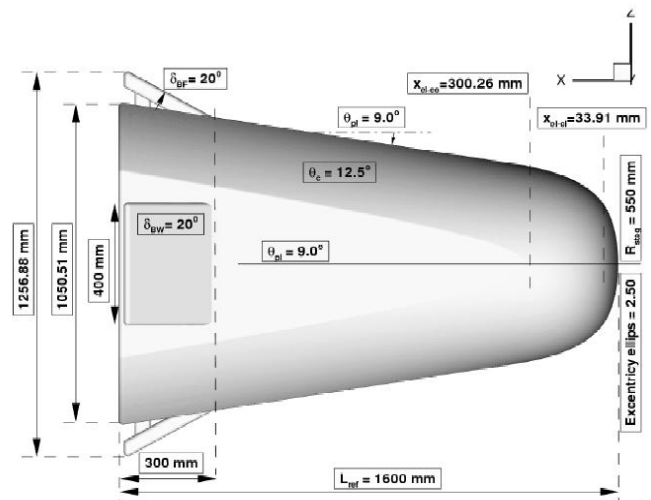


Figure 17 KHEOPS revision 4.2; Side view.

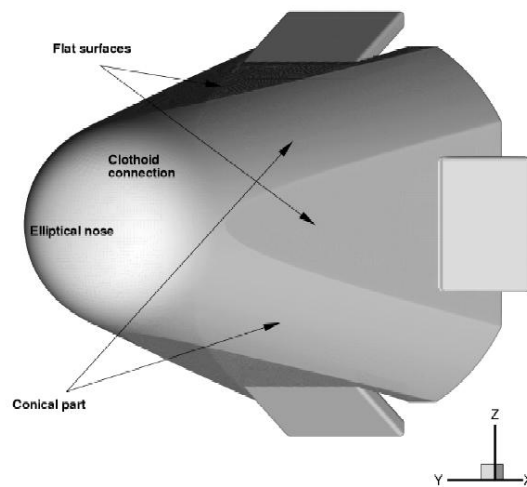


Figure 18 KHEOPS revision 4.2; Perspective view.

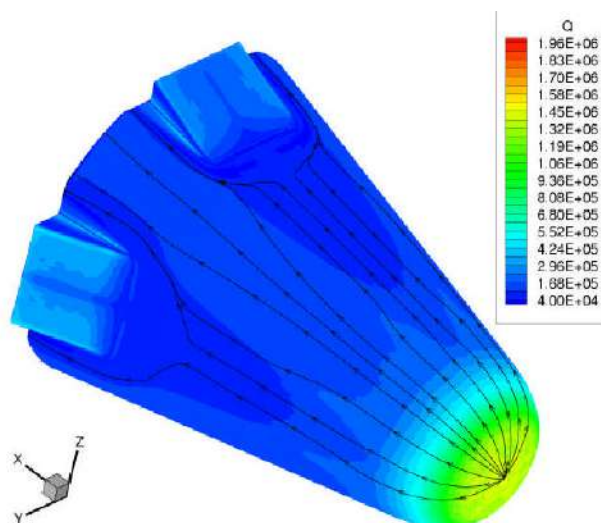
EXPERT vehicles will have a mass varying from 250 to 400. The geometry is shown in Figure 16, Figure 17 and Figure 18.

Figure 19 and Figure 20 show the heat flux distribution assuming non-catalytic and fully catalytic radiative equilibrium wall boundary condition. The influence of wall catalysis is large; partial catalytic wall assumption need to be assumed for the design and layout of the TPS. Figure 8 addresses the influence of mass on stagnation heating. A partial catalytic wall has been assumed for the DLR C-SiC nose<sup>3</sup>.

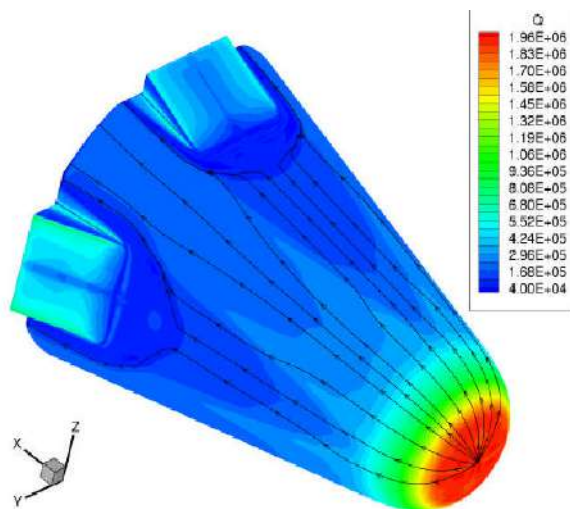
It demonstrates that clean non-contaminated flight environment for detailed flight measurements is possible up to a re-entry speed of 6 km/s. The curve, describing the boundary of passive to active

oxidation will be confirmed again with new detailed plasma facility tests. Figure 8 includes also the theoretical and experimental analysis of Hilfer<sup>4</sup> and recent DLR C-SiC experimental data on the boundary of passive/active oxidation obtained in the DLR L3K facility<sup>5</sup>.

EXPERT will have a C-SiC nose, PM 1000 conical panels for its leading edges, PM1000 flat parts and C-SiC flaps. Its base will consist of FEI or  $\gamma$ -Ti alloy panels.



**Figure 19 Non-catalytic heat flux distribution on peak heating of trajectory for 6 km/sec trajectory.**



**Figure 20 Catalytic heat flux distribution on peak heating of trajectory for 6 km/sec trajectory.**

WIND TUNNEL COVERAGE

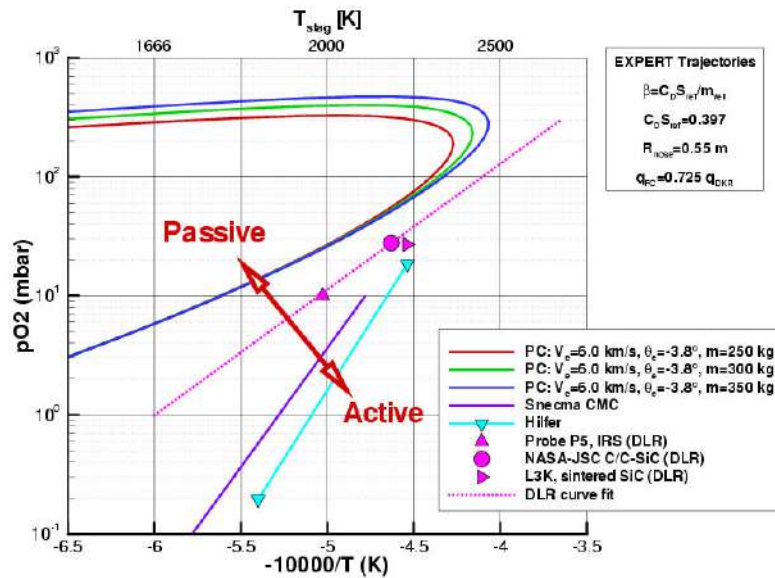


Figure 21 Influence of mass on C-SiC active/passive oxidation boundaries.

In order to study scaling and flight extrapolation, different trajectories are planned to be flown. A unique opportunity is offered here as Mach, Reynolds and binary scaling from flight can be partly duplicated in the newest European and Russian high enthalpy facilities. Figure 22 exhibits three possible EXPERT trajectories in terms of Mach / Reynolds combined with the performance envelopes of the major European hypersonic wind tunnels: F4 and S4 from ONERA; HEG and H2K from DLR; TH2 from RWTH; LONGSHOT from VKI, HTFD from TU Delft and the AT303 from ITAM (Russia). Figure 22 shows the corresponding binary scaling versus speed diagram. Note that the 5 and the 6-km/sec EXPERT trajectories “fly” through calibrated nozzles of F4 and HEG. Comparison of wind tunnel data with flight at these crossing points will greatly advance our understanding of high enthalpy wind tunnel nozzle free stream uncertainties on flight extrapolation and scaling. Indeed influence of free stream pollution, coupling of vibration and dissociation, flow establishment time, influence of electrons, thermo chemical state of free stream, etc..., in present days hypersonic facilities are not fully understood.

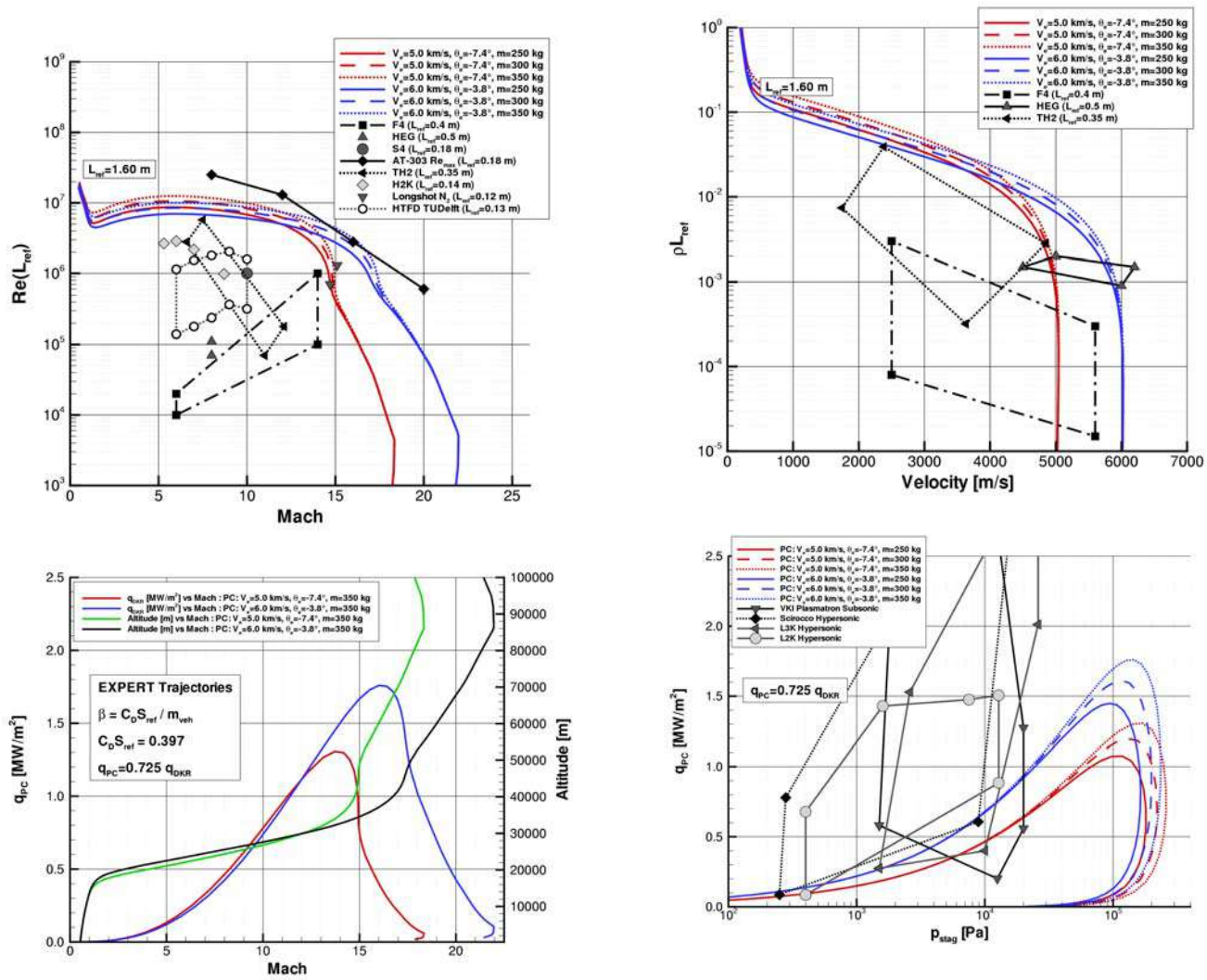


Figure 22 EXPERT trajectories Wind Tunnel Coverage.

THE SCIENTIFIC PAYLOAD

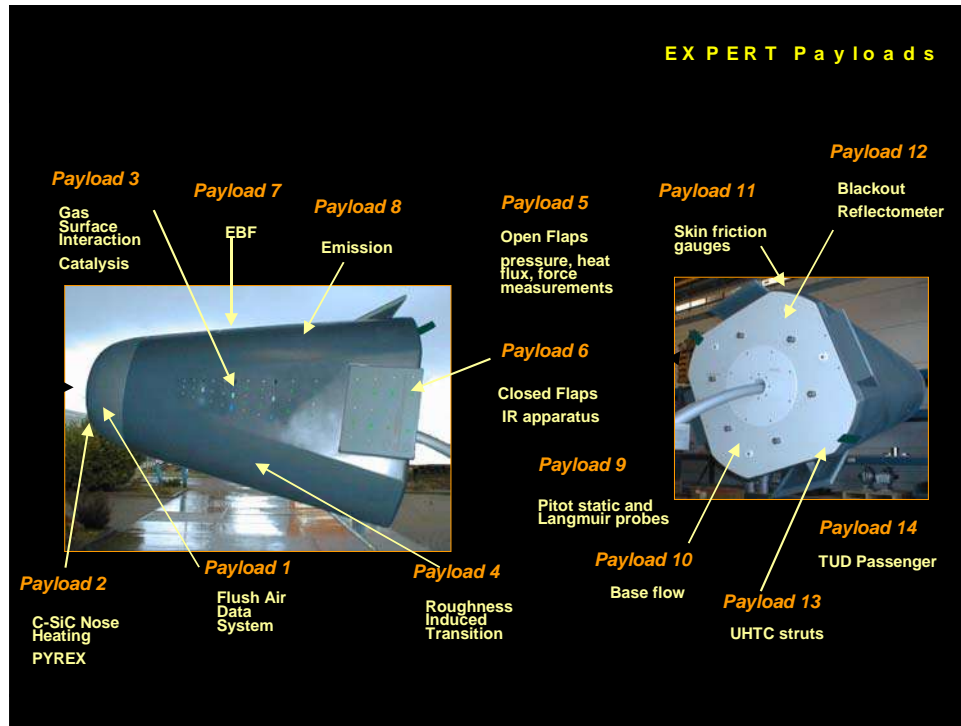


Figure 23 Overview on EXPERT Payloads.

The EXPERT vehicle (as shown in Figure 23) will carry state-of-the-art instrumentation for in-flight measurement of the critical aerothermodynamic phenomena: transition, catalysis, real gas effects on shock interaction, as well as blackout. Special attention will be paid to the design of measurement sensors, as well as to the measurement of the free-stream parameters during reentry (i.e. the design of ADS)

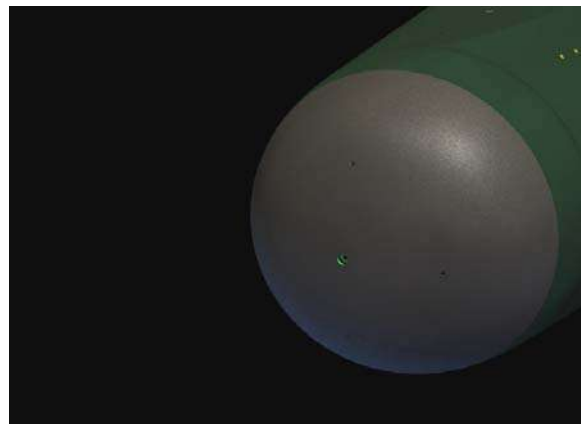


Figure 24 Payload I.

## Aerothermodynamic Reentry Flight Experiments Expert

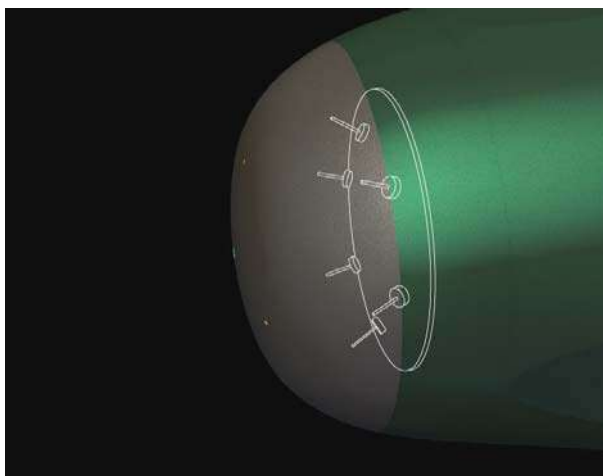
### Payload I + II : Free-stream tracking + Nose Heating Measurement

The nose of the vehicle, featuring high geometrical accuracy and a low surface catalicity, is designed to be an integration platform for both Flush Air Data System and heat flux sensors.

Lessons learned from past flight programmes have shown the importance of correct assessment of the free stream conditions for improved interpretation of onboard measurements.

A pressure-based Air Data System (ADS) (Figure 24) mounted on EXPERT's nose will provide free stream dynamic pressure, angle of attack and sideslip angle. Raflex gages are planned to be used as ADS sensors featuring combined pressure and heat flux measurements. These heat flux measurements will be compared with those obtained from Payload II, *i.e.* PYREX measurements.

The goal of the latter payload (PYREX) is to determine the temperature history and corresponding heat fluxes at six locations on the nose (Figure 25). Technology readiness is assured by the fact that EXPERT will take advantage of instrumentation originally developed for the X38 experimental vehicle to measure temperatures in the nose region.(Figure 26 and Figure 27 show the PYREX temperature system fully qualified and installed in the nose of the X-38 vehicle.)



**Figure 25 Payload II.**



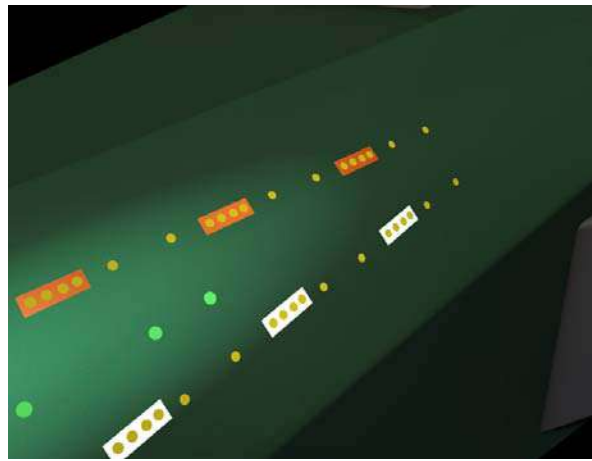
**Figure 26 C-SiC Nose (courtesy IRS).**



**Figure 27 Nose Instrumentation (courtesy IRS).**

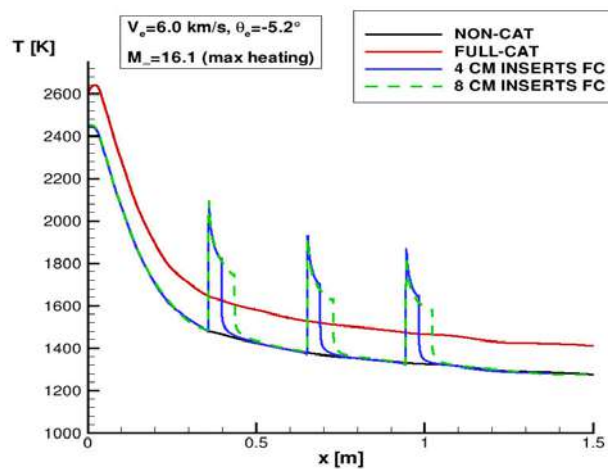
Payload III : Catalysis measurements

The assessment of the catalytic gas-surface interaction is a major concern when designing a thermal protection system. The degree of catalicity of a material affects the heating of the surface and thus the design of the protection needed. Understanding this phenomenon calls for very complex modelling at the molecular level, which can only be partly validated in ground-based plasmatron facilities. A series of temperature gages, each covered with coatings with different degrees of catalicity, are foreseen to be flown on two diametrically opposite leading edges of EXPERT to study the phenomenon. Figure 28 shows two sets of coated inserts mounted on the leading edges.

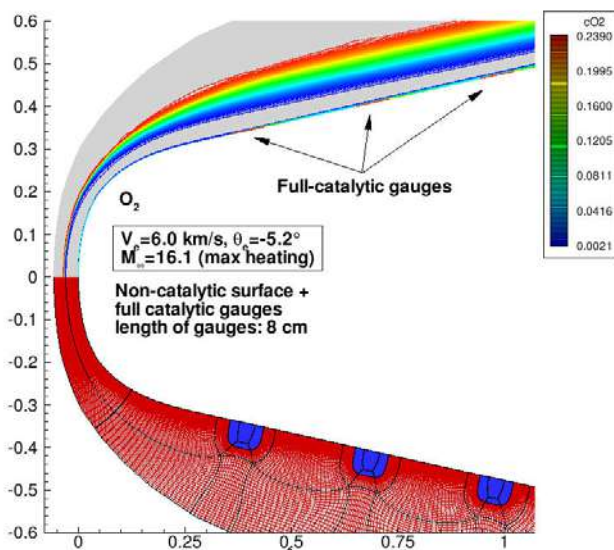


**Figure 28 Payload III.**

Figure 29 and Figure 30 demonstrate the expected overshoot in wall temperature (above the full catalytic wall assumption) when the atoms in the nonequilibrium boundary layer recombine at the fully catalytic inserts.



**Figure 29 Full Catalytic patches simulation.**



**Figure 30 Numerical simulation grid and results.**

This computation leads to the conclusion that enough resolution is available to perform good flight measurements.

From an experimental point of view two main issues have to be addressed, namely the selection of catalytic materials for the inserts and the design of measurement procedures leading to accurate heat flux values.

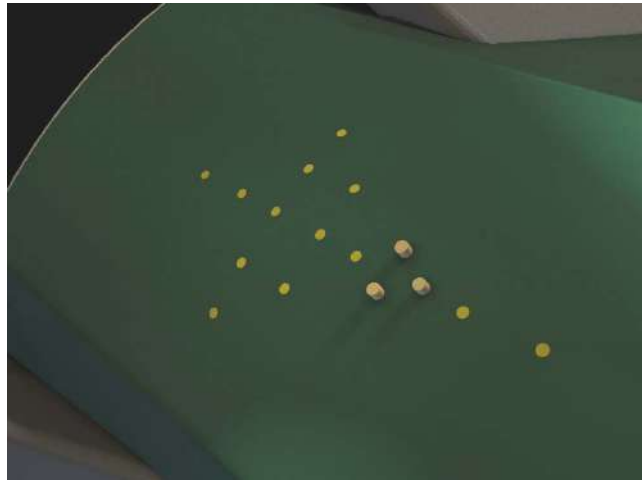
After a preliminary selection of sample candidate materials and coatings, which will happen in Ground testing facilities, the experiment will be evaluated via CFD analysis.

Traditional sensors as well as non-conventional devices are foreseen to be part of Payload III.

In addition to classical thermocouples, pyrometrical temperature measurements will be performed on both the so-called catalicity layout (line of patches featuring different levels of catalicity perpendicular to the airflow) and the so-called relaxation layout (line of patches featuring the same level of catalicity along the airflow). From the computed heat fluxes the dissociation degree of the airflow and the relaxation effects will be estimated.

Since the gas-surface interaction is driven by material catalytic characteristics and chemical processes in the flowfield, a spectroscopic diagnostic tool will be included in Payload III.

The chemical composition of a narrow volume located at a short distance from the surface will be assessed via comparison between the experimental and already available spectra of O, N, O<sub>2</sub>, N<sub>2</sub> and NO. Since a spectroscopic analysis is more accurate than the usual temperature evaluation, more information could be collected and used for heterogeneous catalysis models validation.



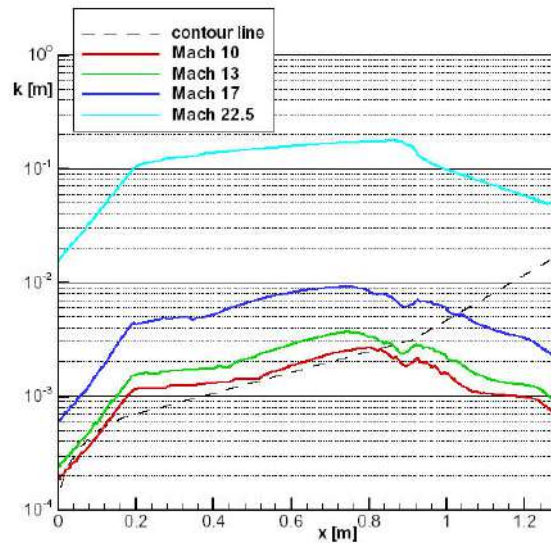
**Figure 31 Payload IV.**

Payload IV: Roughness-induced transition

Laminar to turbulent boundary-layer transition is considered one of the most critical aerothermodynamic phenomena due to the associated local temperature peaks and drag increase; unfortunately it is not yet fully understood from a physical point of view and hypersonic transition prediction based on ground test extrapolation-to-flight is not reliable. In fact, chemistry effects are difficult to simulate in ground facilities and cold hypersonic facilities are affected by external disturbances (wind tunnel related), which constitute dominant sources of perturbations for transition triggering.

Thus, only flight experiments with well-characterised disturbances (triggering transition where required) may provide essential information to be coupled with ground facilities data and numerical simulation results. Roughness-inducing boundary-layer transition elements will be mounted on the leading edges of EXPERT in diametrically opposite locations. Their position, size and number will be chosen such that transition occurs in the lower altitude, higher Reynolds number part of the flight. Heat flux sensors will detect transition.

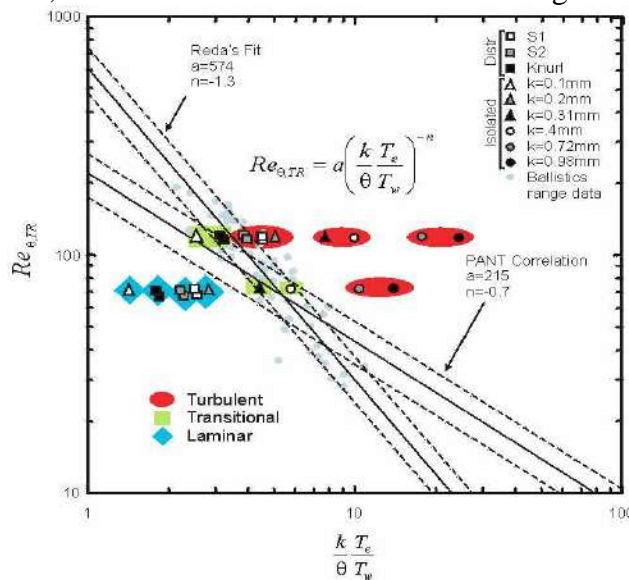
Figure 32 show the roughness heights inducing transition for several Mach numbers along trajectory.



**Figure 32 Roughness height along EXPERT geometry.**

The remaining edges will be kept smooth in order to have a reference clean condition to be compared against the induced transition behaviour.

Figure 31 shows a typical roughness element layout, whereas Figure 33 addresses typical roughness induced transition correlations, which need to be validated via new flight data.



**Figure 33 Experimental activities on Roughness induced transition (courtesy VKI).**

At this point, the importance of analysing smooth surfaces has to be remarked: in fact, the experiment will be successful only if no transition is triggered by surface discontinuities before the roughness elements are reached. That is why Payload IV addresses both surface discontinuities triggered transition and roughness element induced transition via CFD + stability analysis, wind tunnel test campaigns and flight tests.

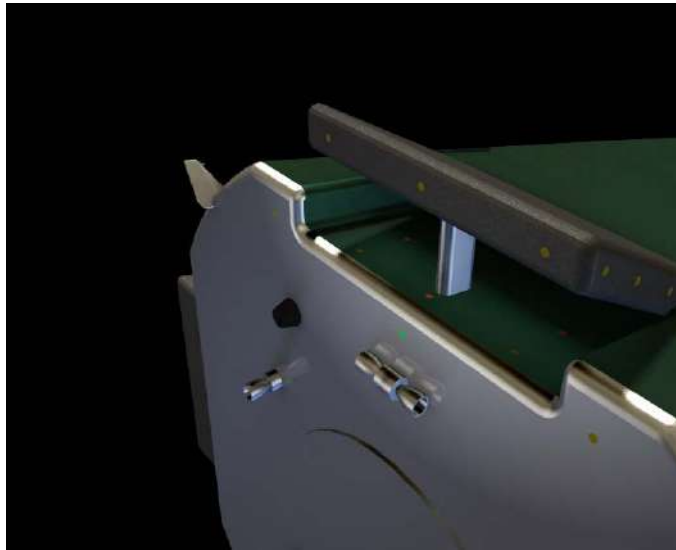


Figure 34 Payload V.

Payload V : Shock interactions around open flaps

Boundary-layer separation effects in front of a deflected flap (Figure 35) affect not only the

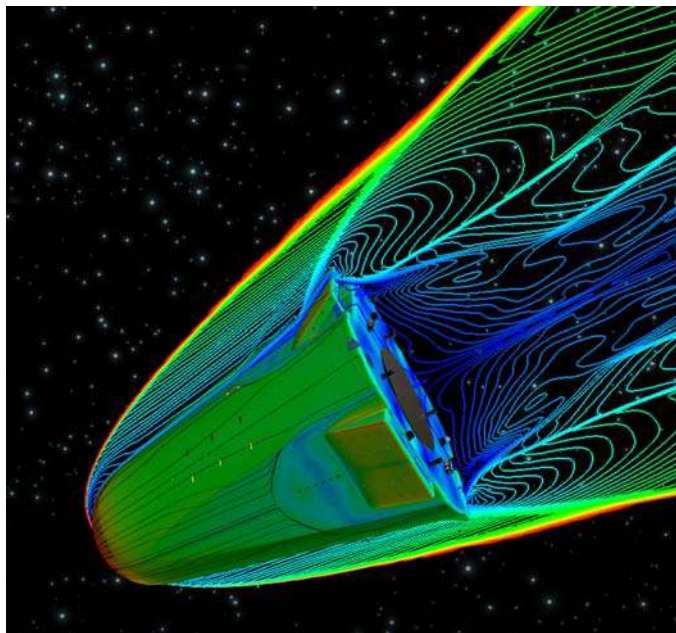
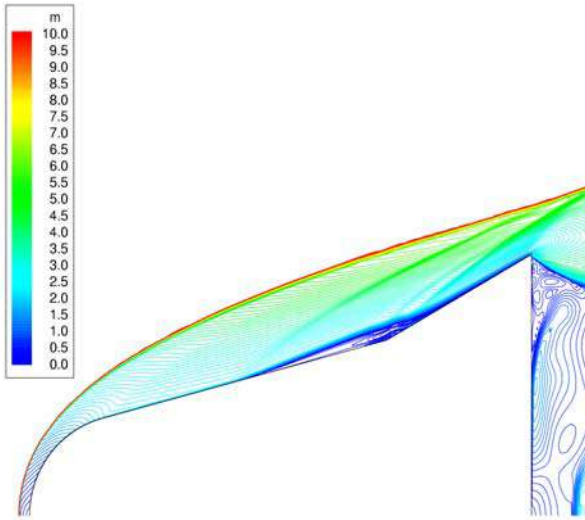


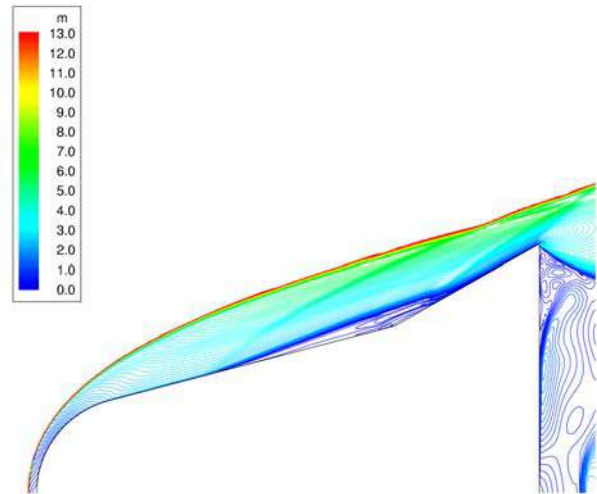
Figure 35 3D Flowfield around the vehicle.

flap for control purposes, but also the heating associated with shear-layer reattachment.

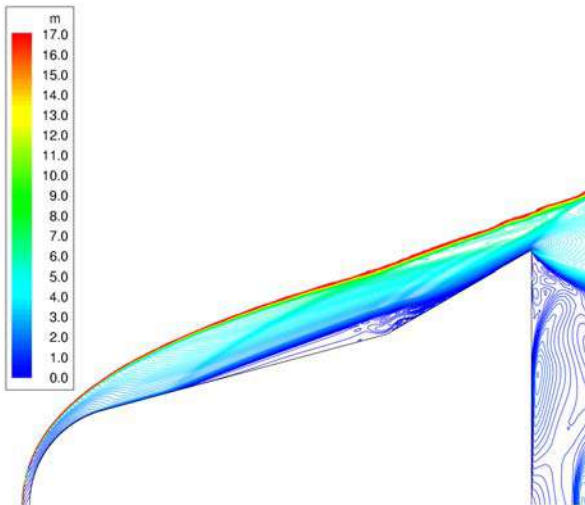
Figure 36 to Figure 39 show the typical variation of viscous interaction effects that occur on a deflected flap during re-entry. Separation bubbles change in size during re-entry and affect not only flap efficiency but also the heating associated with shear layer reattachment.



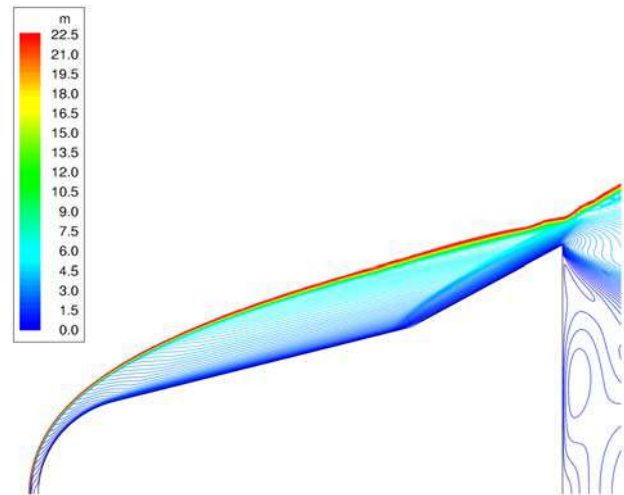
**Figure 36**  $M_\infty = 10$  contour plots of axisymmetric NS non-equilibrium computations.



**Figure 38**  $M_\infty = 12.9$  contour plots of axisymmetric NS non-equilibrium computations.



**Figure 37**  $M_\infty = 17$  contour plots of axisymmetric NS non-equilibrium computations.



**Figure 39**  $M_\infty = 22.5$  contour plots of axisymmetric NS non-equilibrium computations.

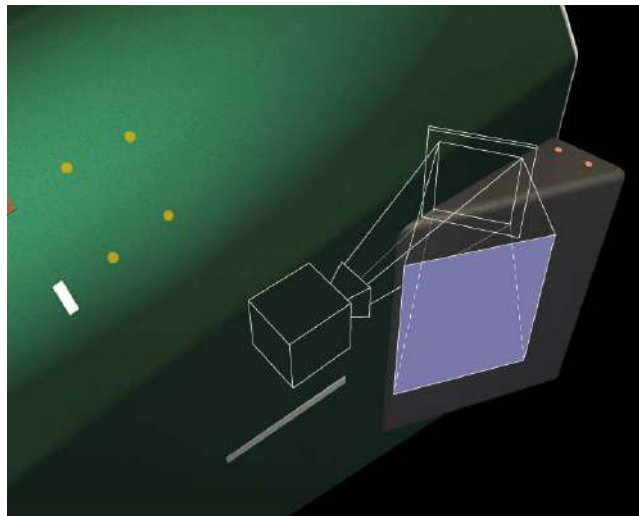
Three dimensional effects, corner and gap heating, base-flow circulation and wall cooling are all critical issues that need to be addressed in the design of control flaps. The set-up proposed for EXPERT consists of a space-vehicle ceramic flap with fixed actuator instrumented with simple but reliable devices such as thermocouples, heat and pressure gages, strain gages and micro-pyrometers (Figure 34).

In order to derive extrapolation-to-flight criteria able to reproduce both the mechanical and thermal loads acting on the control surface, a number of experimental tests will be performed. The EXPERT flight conditions in the flap region will be characterized by means of CFD and ground experimental activities. Also the flat faces upstream the flap are foreseen to be instrumented.

Payload VI : Heat fluxes inside closed flaps

The two closed flaps will be instrumented to measure accurately temperature and pressure in the reattached flow region and heat fluxes on the rear face. In particular one flap will feature unconventional measurement techniques, whereas an array of conventional sensors will be mounted on the opposite side for calibration and comparison.

To assess the location of the reattachment line with good accuracy, temperature and pressure sensitive paints will be used. The paints are foreseen to cover a sapphire window imbedded in the C/SiC flap.

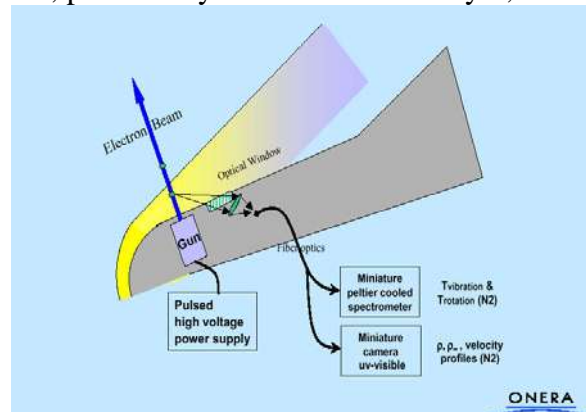


**Figure 40 Infrared camera.**

Taking advantage of today’s capabilities for measuring time-dependent 3D phenomena using non-intrusive techniques, an infrared camera (Figure 40) will be mounted inside the closed flaps. Inverse methods will be applied to the data measured beneath the flaps in order to ‘reconstruct’ the external 3D heat flux during re-entry. As the deflection of all four flaps is identical, the flow results can be crosschecked with those predicted using the more classical methods.

Payload VII + VIII: Shock-layer chemistry

When computing a hypersonic flowfield, the thermo-chemical model used plays a dominant role because it strongly affects the results of the numerical simulations. Unfortunately, those applicable to hypersonic flight could not yet be fully validated and hence there is an acute need for a reliable set of thermo-chemical measurements, particularly within the shock layer, which EXPERT can provide.



**Figure 41 EBF (courtesy ONERA).**

An instrument (Figure 41) based on the electron beam fluorescence technique is foreseen to be flown on EXPERT; it is expected to perform measurements of vibrational temperature, rotational temperature and concentrations of molecular nitrogen and nitrogen oxide in the flowfield, particularly in one point outside the shock layer and in one point inside the shock layer.

Figure 42 to Figure 45 show the N<sub>2</sub> concentrations in the shock layer of the EXPERT vehicle during re-entry. Very valuable data can be derived from such an experiment for validation of thermo-chemical models complementing those obtained in ground-based facilities.

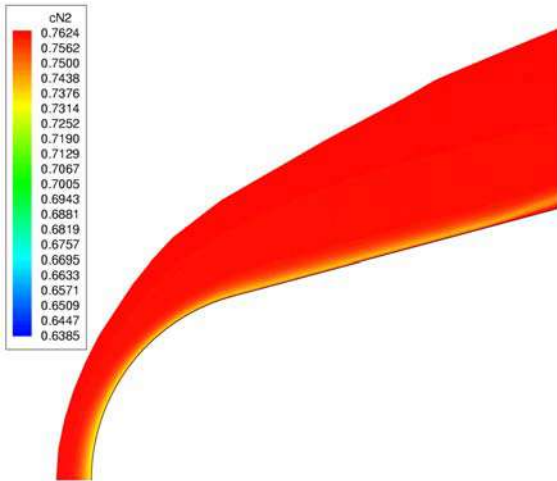


Figure 42 N<sub>2</sub> concentration at  $M_\infty=10$  for catalytic wall assumption.

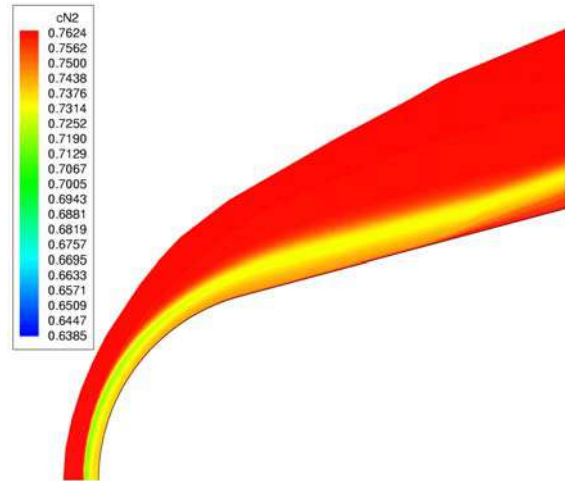


Figure 44 N<sub>2</sub> concentration at  $M_\infty=12.9$  for catalytic wall assumption.

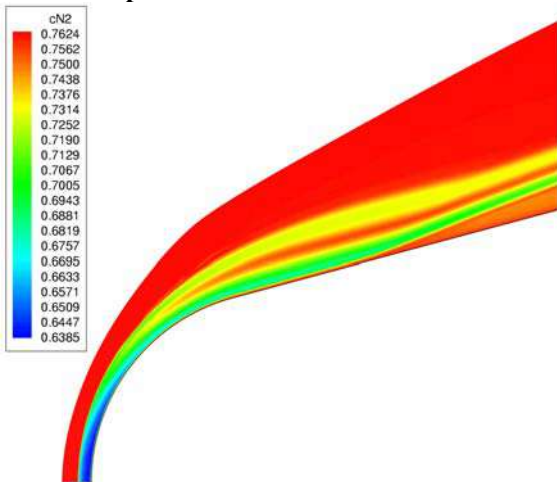


Figure 43 N<sub>2</sub> concentration at  $M_\infty=17.0$  for catalytic wall assumption.

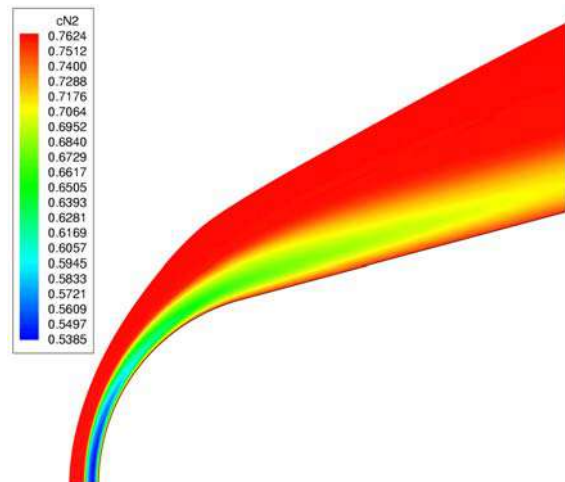


Figure 45 N<sub>2</sub> concentration at  $M_\infty=22.5$  for catalytic wall assumption.

The EBF Payload has to be considered as a subsystem, featuring an electron gun, a spectrometer, a camera for detection, own battery, etc.; the miniaturised electron gun is the most challenging component to design and build, because it affects the ability of the electron beam to penetrate the flowfield.

The ions are produced through an electrical discharge between the anode (wire) and the wall. They are accelerated towards the cathode; their impact results in the extraction of electrons.

## Aerothermodynamic Reentry Flight Experiments Expert

The electrons are then accelerated counter wise and are collimated into a thin beam by the geometry of the system. The current technological development focuses especially on the extension of the operation domain towards higher values of free-stream densities.

In parallel, an optimised integration between EBF and vehicle is under investigation.

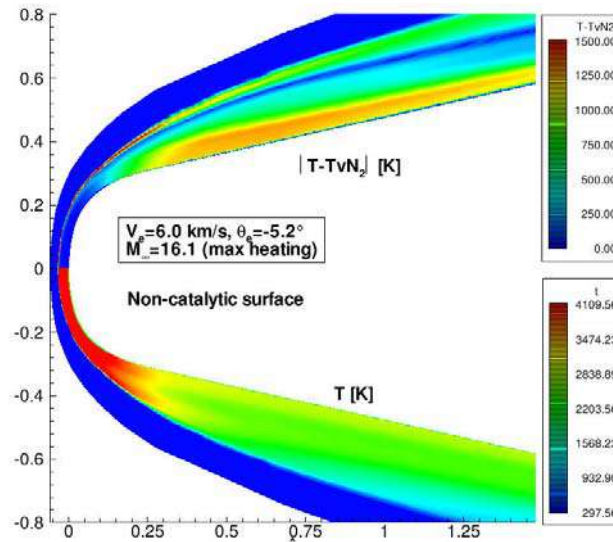


Figure 46 Numerical simulation of the relevant temperatures.

Figure 46 demonstrates that present day nonequilibrium tools show large difference between rotational and vibrational temperature in a region downstream of nose/cone junction justifying the use of an EBF for in-flight measurements.

The EBF Payload mainly aims at providing valuable data for validation of the thermo-chemical models and complementing the information obtained from ground-based facilities.

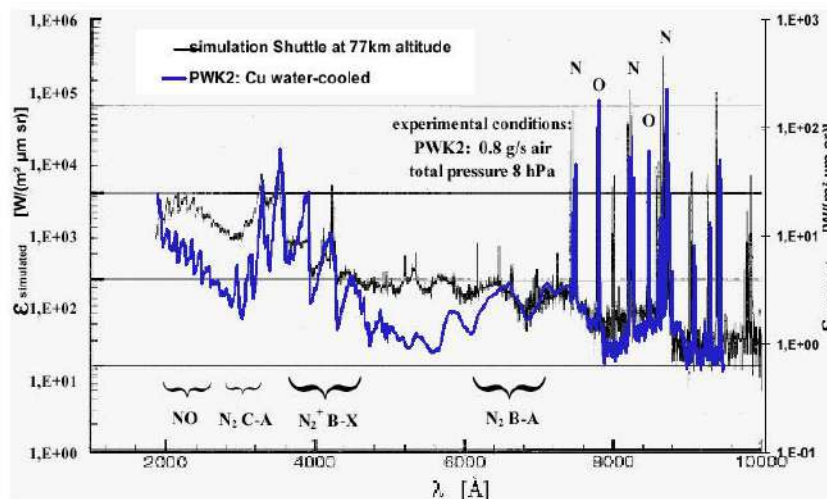
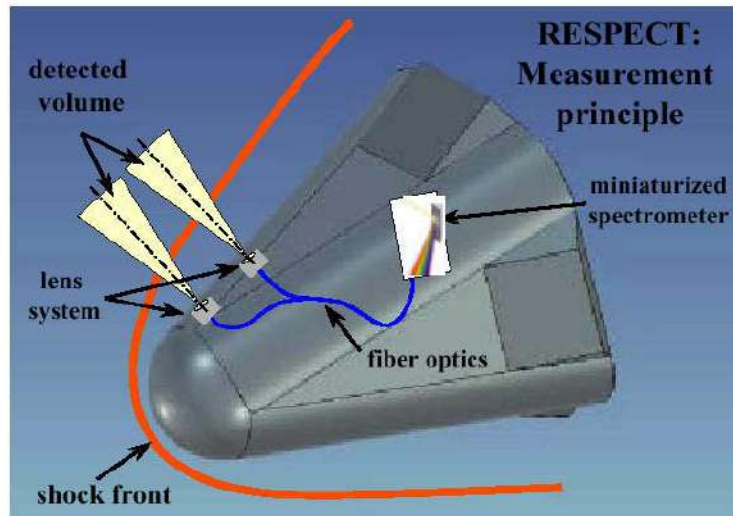


Figure 47 Spectral simulation and Plasma Wind Tunnel experiment (courtesy IRS).

In addition to the EBF, RESPECT is planned to be flown. This instrument aims at collecting spectroscopic information during re-entry through spectrally resolved emission; the experimental data will then be compared with coupled flowfield/radiation codes leading to the validation of used thermo-chemical models. The RESPECT subsystem (Figure 48 shows a two channel device) consists of a miniaturized spectrometer, optical fibers and a lens system; the foreseen spectral range is 200-800 nm.



**Figure 48 RESPECT mounted on EXPERT (courtesy IRS).**

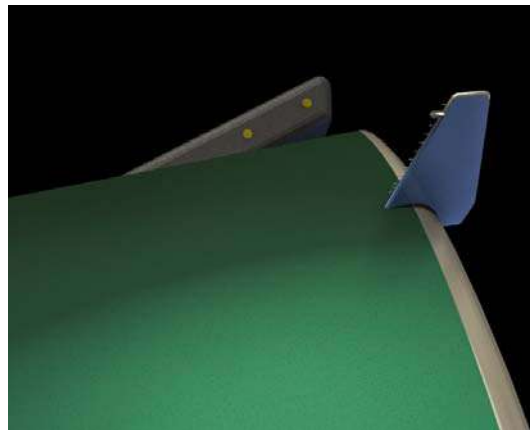
The challenge of this flight instrument lies in the design of the electronics supporting the spectral measurement and the optical window through the heat shield. Preliminary activities performed at IRS demonstrated the feasibility of such a procedure. Figure 47 shows first comparisons between computed and in Plasma Wind Tunnel measured spectra.

Payload IX : Boundary-layer measurements

At the trailing edge, EXPERT will be equipped with a Pitot static pressure rake and a Langmuir probe in order to measure, respectively the boundary-layer characteristics and the electron density profiles close to the wall.

The critical issues to be tackled are related to the conceptual design of the probes, including the selection of the material, the definition of the attachment points and the location and type of transducer.

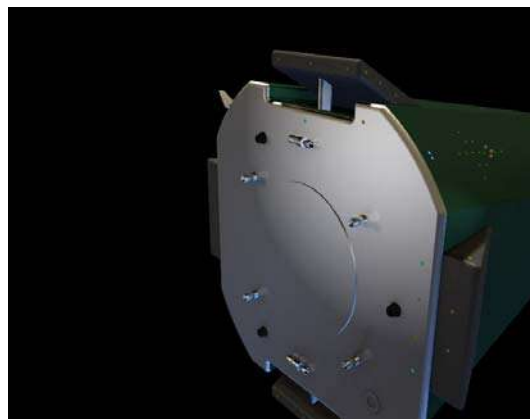
The resulting characterisation of the boundary layer at the trailing edge of the vehicle will further contribute to our understanding of boundary-layer transition phenomena (Figure 49).



**Figure 49 Payload VIII**

Payload X : Base flow measurements

This Payload aims at measuring steady and unsteady loads on the base of the vehicle. Local base pressure and heat flux measurements will be made to study the complex base recirculation flow in between the flaps and possibly the Reaction Control System-plume interference effects (Figure 50).



**Figure 50 Payload IX.**

**Payload XI : Skin Friction Measurements**

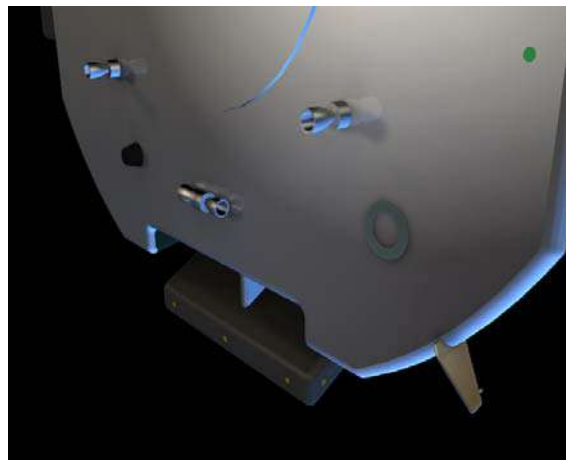
A slip flow sensor is foreseen to be integrated in the EXPERT vehicle: this combined probe mainly designed for surface flow diagnostics in the slip- and rarefied flow regimes may also be used in the laminar continuum flow regime.

Depending on the flow regime the following quantities may be measured:

Flow quantity	Slip flow regime	Continuum Flow
Surface Pressure		⊕
Heat Flux	⊕	⊕
Particle flux to surface	⊕	
Slip speed ratio	⊕	
Skin friction		⊕

**Table 1 Payload X Diagnostics (courtesy HTG).**

The slip flow sensor has been designed with two inclined pressure taps, which are integrated in one caloric copper sensor head, ensuring same temperature for the cavities of both probes.



**Figure 51 Payload XI.**

**Payload XII : Black-out measurements**

Predicting the blackout phase is not an easy task, because it depends on the electron density map, which in turn depends on the thermo-chemical models used. Blackout duration can be reduced by optimising TM/GPS antennas design and location.

This payload aims at studying re-entry plasma electron density (also with the help of Langmuir probes) and the associated radio-link attenuation patterns, via an extended radio-frequency (RF) reflectometric system (Figure 51).



**Figure 52 Payload XIII.**

### Payload XIII : Sharp Hot Structures

The objective of this payload is to fly an instrumented patch of UHTC material. The payload could be a bulk ceramic component or coated component (UHTC covered with anti-oxidation UHTC). The flight test aims at monitoring the thermal conditions of the structure. Two symmetric locations are foreseen for this Payload.

The UHTC could be integrated on dummy winglets, similar to the Pitot static rakes or on a small deflected surface at trailing edge of the vehicle leading edge.

### Payload XIV : Thermal protection passenger

Based on an idea emanating from the Technical University of Delft (NL), it is planned to fly a small innovative water-cooled thermal-protection system as a passenger on EXPERT (Figure 52). If successful, such a system could be used to reduce nose radius and/or leading edge radius for increased L/D future winged re-entry vehicles. The enhanced radiation cooling concept consists of a super alloy outer skin and a porous alumina filled with water, separated by a gap. The porous material is kept at low temperatures due to evaporation, thus allowing both external and internal radiation coming from the metal heat shield.

### CONCLUSIONS

EXPERT is an in-flight research programme, with the objective to improve our understanding of critical aerothermodynamics phenomena such as transition, catalysis, blackout, real gas effects and shock wave boundary layer interactions associated with flap efficiency and heating. It includes multiple VOLNA flights on generic configurations and focuses on wind tunnel to flight extrapolation as well as on the flight measurement techniques integration themselves. At present two ballistic flights (5 and 6 km/sec) are planned. If successful, it is believed that other flights are possible such as for higher speed (7 km/sec); future flights for the study of transitional flow phenomena and skipping trajectories, jet interaction, demonstrator for MHD/nose heat flux reduction schemes and flights for the study of advanced materials associated with high-speed re-entry.

### ACKNOWLEDGEMENT

The authors acknowledge the FESART team for their contributions in the feasibility study preceding the EXPERT project as well as the partners from the Phase B, presently on-going:

ALENIA, EADS, CIRA, ALCATEL, ALTA, ASTRIUM, Bradford Engineering, CENTROSPAZIO, CSM, DLR, Dutch Space, ETCA, HTG, HTS-RUAG-ETH-CFS-EPFL-SMR, IRS, M.A.N., ONERA, PLANSEE, SABCA/SONACA, SAS, SENER, SNECMA, Spacebel, TUD, University of Naples (DISIS), University of Rome "La Sapienza" (DMA), University of Turin, VKI.

The authors are also indebted to Dr. Danilkin and his team from SRC for VOLNA launcher specifications.

Finally a special thanks to the ESA Publications Division.

### REFERENCES

1. EXPERT FESART Study, SY/E n° 135 946, EADS Launch Vehicles
2. FESART/EXPERT Aerodynamic and Aerothermodynamic analysis of the REV and KHEOPS configurations, ESA Technical Report, TOS-MPA/2718/LW, L. Walpot and H. Ottens
3. Private communication with Doug Fletcher (VKI).
4. Experimentelle und theoretische Beitrage zur Plasma-Wand-Wechselwirkung keramischer Hitzeschutzmaterialen unter Wiedereintrittsbedingungen, ISBN 3-8265-7118-5, Hilfer G., Shaker-Verlag, Aachen, 2000.
5. Milestones Towards Hot CMC Structures for Operational Space Reentry Vehicles, IAC-02-I.3.04, Hald H., Weihs H., Reimer T., 2002.



# EXPERT

## Aerothermodynamic Reentry Flight Experiments

Jean Muylaert

and

L. Walpot, H. Ottens, F. Cipollini

ESA ESTEC

## Course Roadmap

- **Flight Experimentation Logic**
- **Motivation for in flight research**
- **EXPERT requirements**
- **Vehicle design and Flight instrumentation**
- **Conclusions**

# IN FLIGHT EXPERIMENTATION STRATEGY

## 1. FULL SCALE 1 FLIGHT :

- e.g. - SHUTTLE, BOURANE, APOLLO, SHENZHOU, ARIANE 5, HUYGENS
- HOPE, HERMES, OSP
  - HERCULES, SOCRATES

## 2. EXPERIMENTAL DEMONSTRATOR VEHICLES :

- e.g. - X23, X24, X38, AS201, AS202, APOLLO 4,6 ARD,
- BOR4 for TPS ; BOR5 for GNC;
  - OREX, HYFLEX for TPS ; ALFEX for GNC
  - MAIA, PHOENIX 1 and 2 for GNC
  - FLPP IXV ( PRE-X – USV )

## 3. IN FLIGHT RESEARCH VEHICLES

- e.g. - SHARP B1, B2 FLIGHTS, HYSHOT, X43,
- IRDT, PAET, RAMC, FIRE
  - MIRKA, EXPRESS, *SHEFEX*, SFYFE
  - *EXPERT*

## Course Roadmap

- **Flight Experimentation Logic**
- **Motivation for in flight research**
- **EXPERT requirements**
- **Vehicle design and Flight instrumentation**
- **Conclusions**

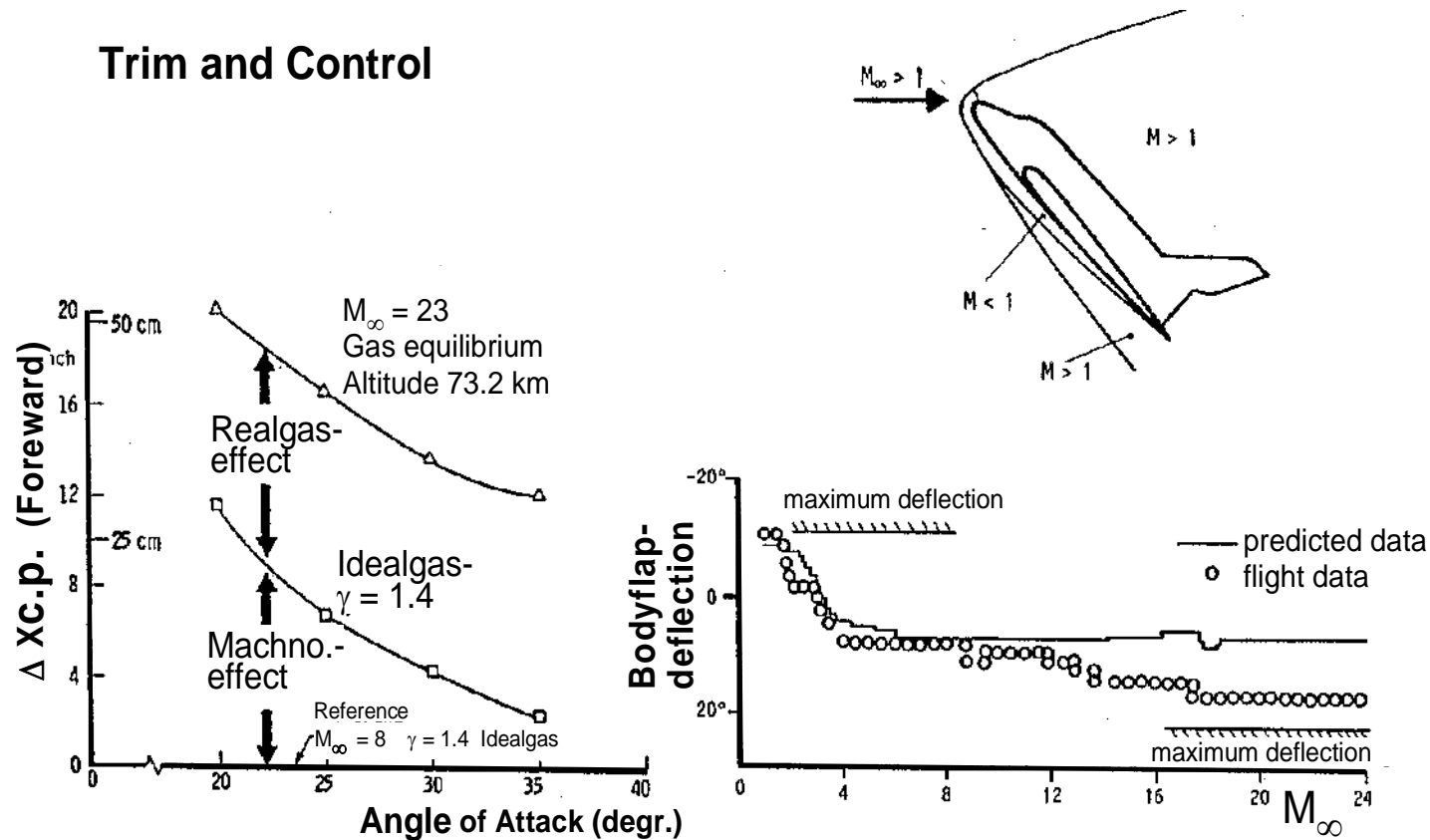
## **MOTIVATION**

**LESSONS LEARNED FROM ARD, MIRKA POST FLIGHT ANALYSIS, X38, AND ESA TECHNOLOGY PROGRAMS SUCH AS MSTP AND FESTIP:**

- 1. NEED FOR COHERENT HYPersonic DATA ASSOCIATED WITH CRITICAL HYPersonic PHENOMENA SUCH AS REAL GAS CHEMISTRY, CATALYTICITY, TRANSITION**
- 2. NEED TO IMPROVE USE OF HYPersonic, HIGH ENTHALPY AND PLASMA FACILITIES IN A VEHICLE DESIGN PROCESS BY TESTING FLOWN CONFIGURATIONS IN ORDER TO CONSOLIDATE WINDTUNNEL TO FLIGHT STRATEGIES**
- 3. NEED FOR IMPROVED WIND TUNNEL AND FLIGHT INSTRUMENTATION INCLUDING AIRDATA SYSTEMS**

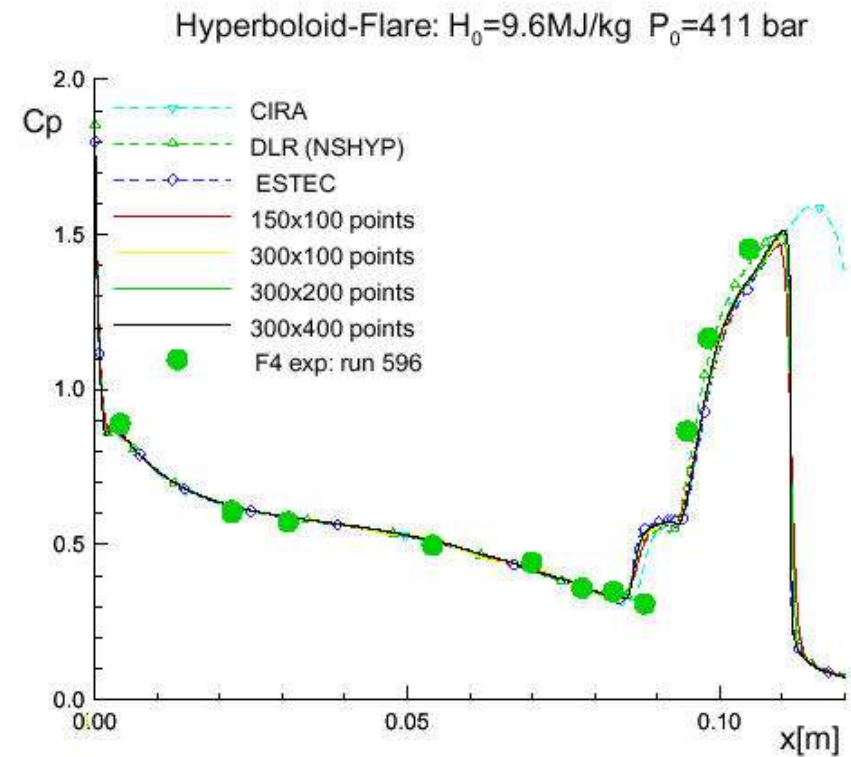
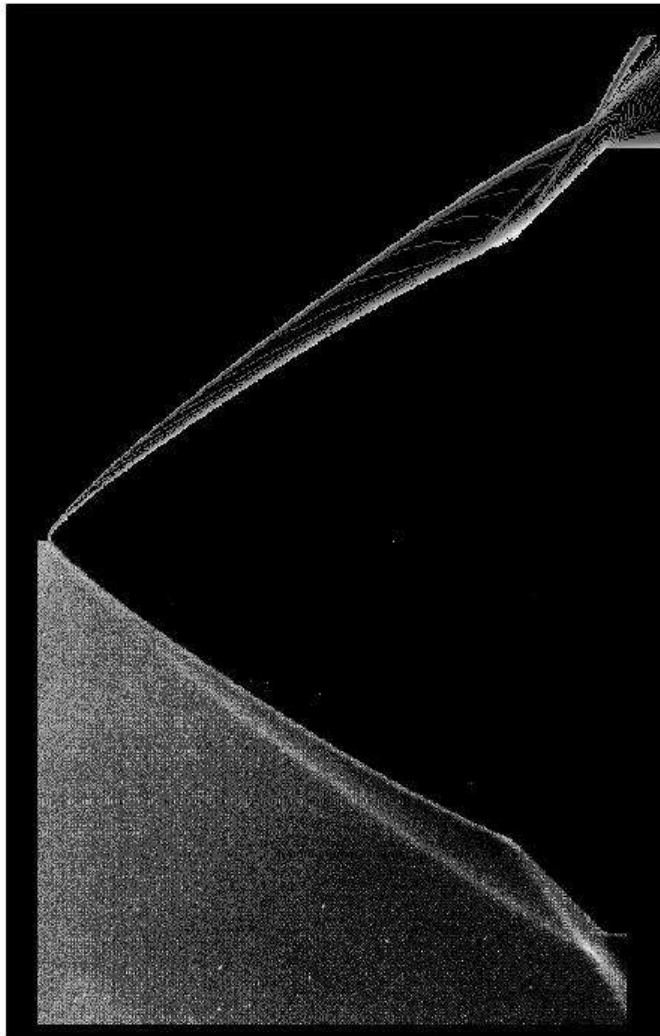
# Shuttle Trim Anomaly

## Trim and Control

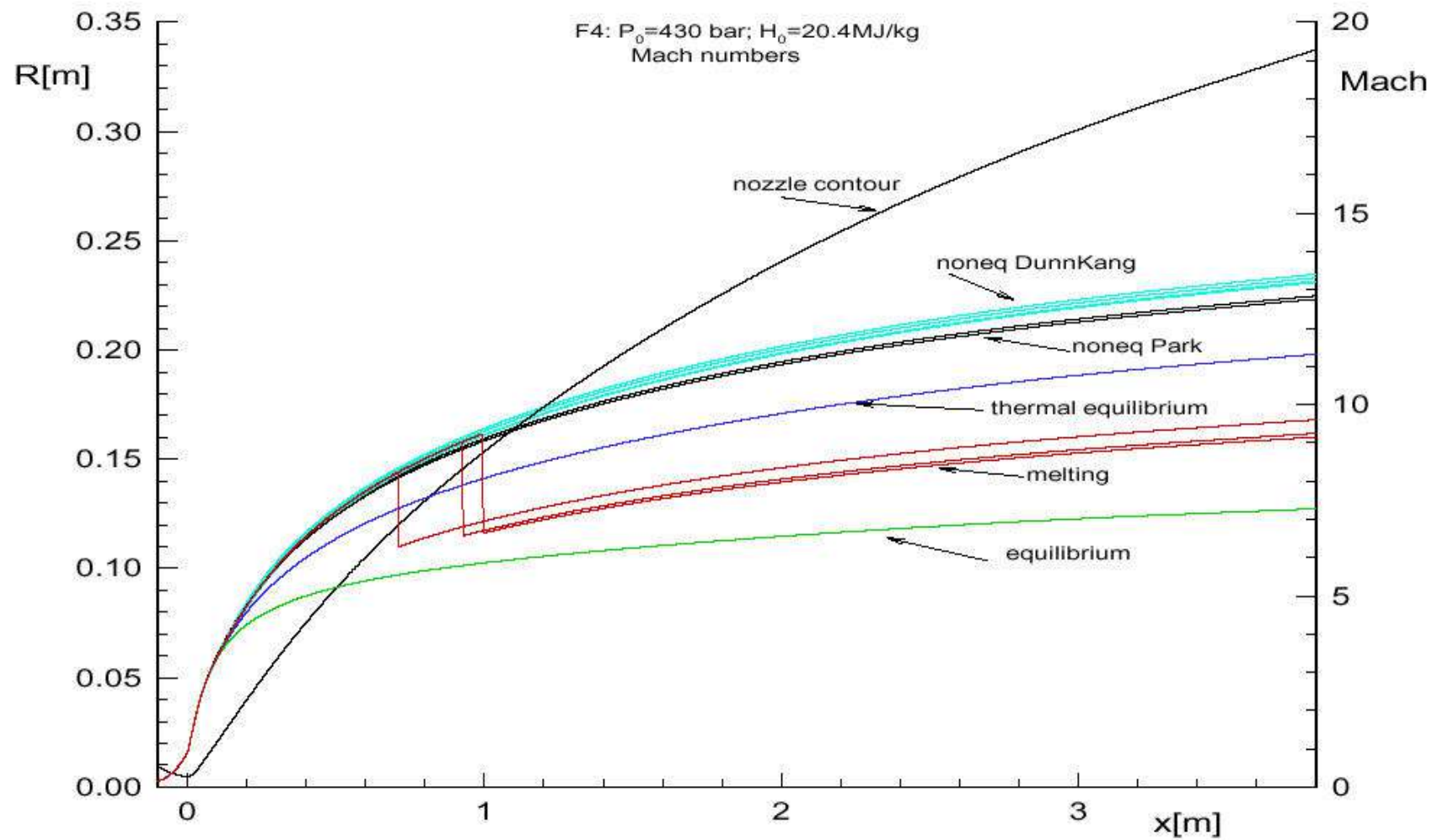


Ref.: G. Laruelle/T. Bonnefond/P. Sacher, Flight Testing for Hypersonic Speed An European view, AGARD CP 600, C31-1, 1997 (Paris)

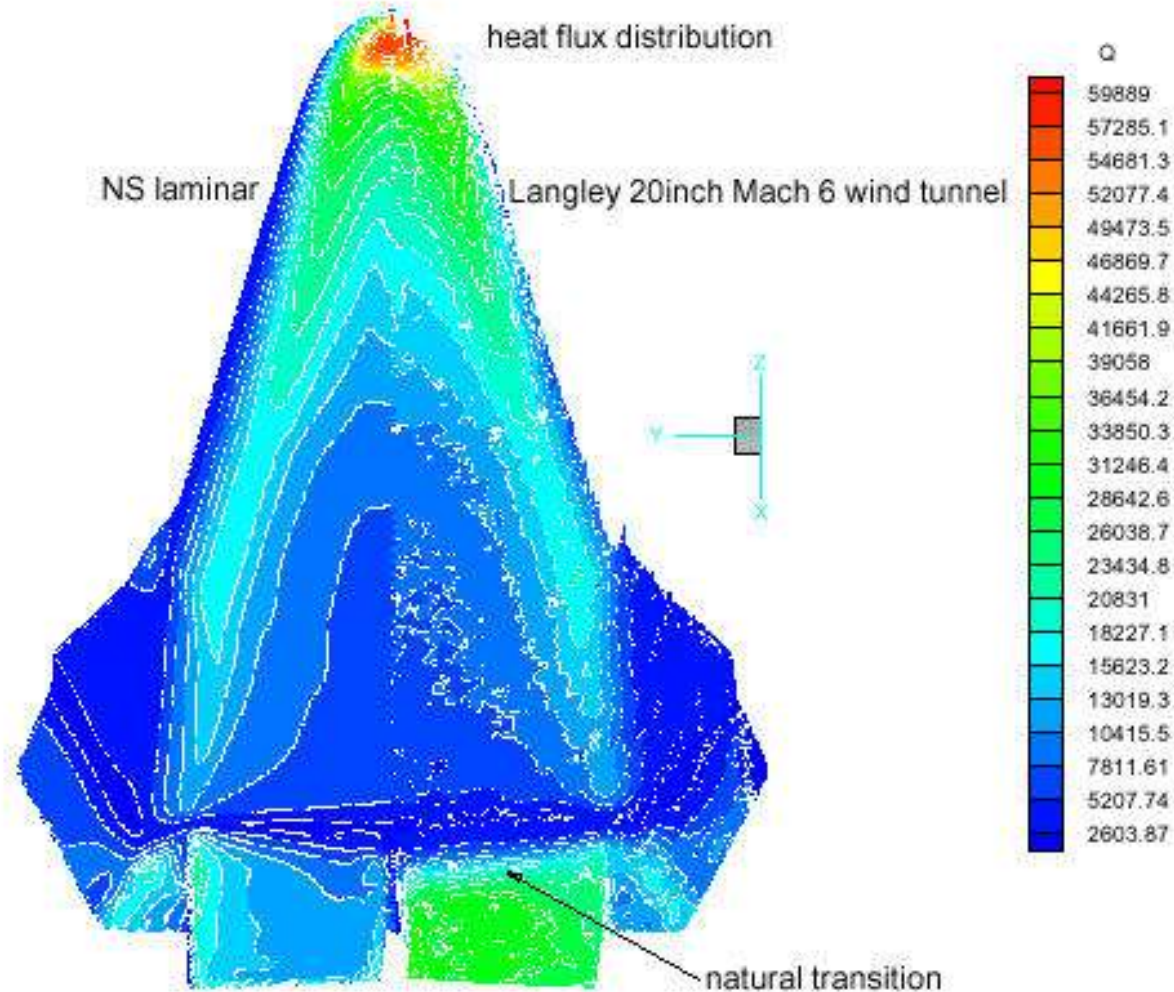
# Hermes Hyperboloid Flare



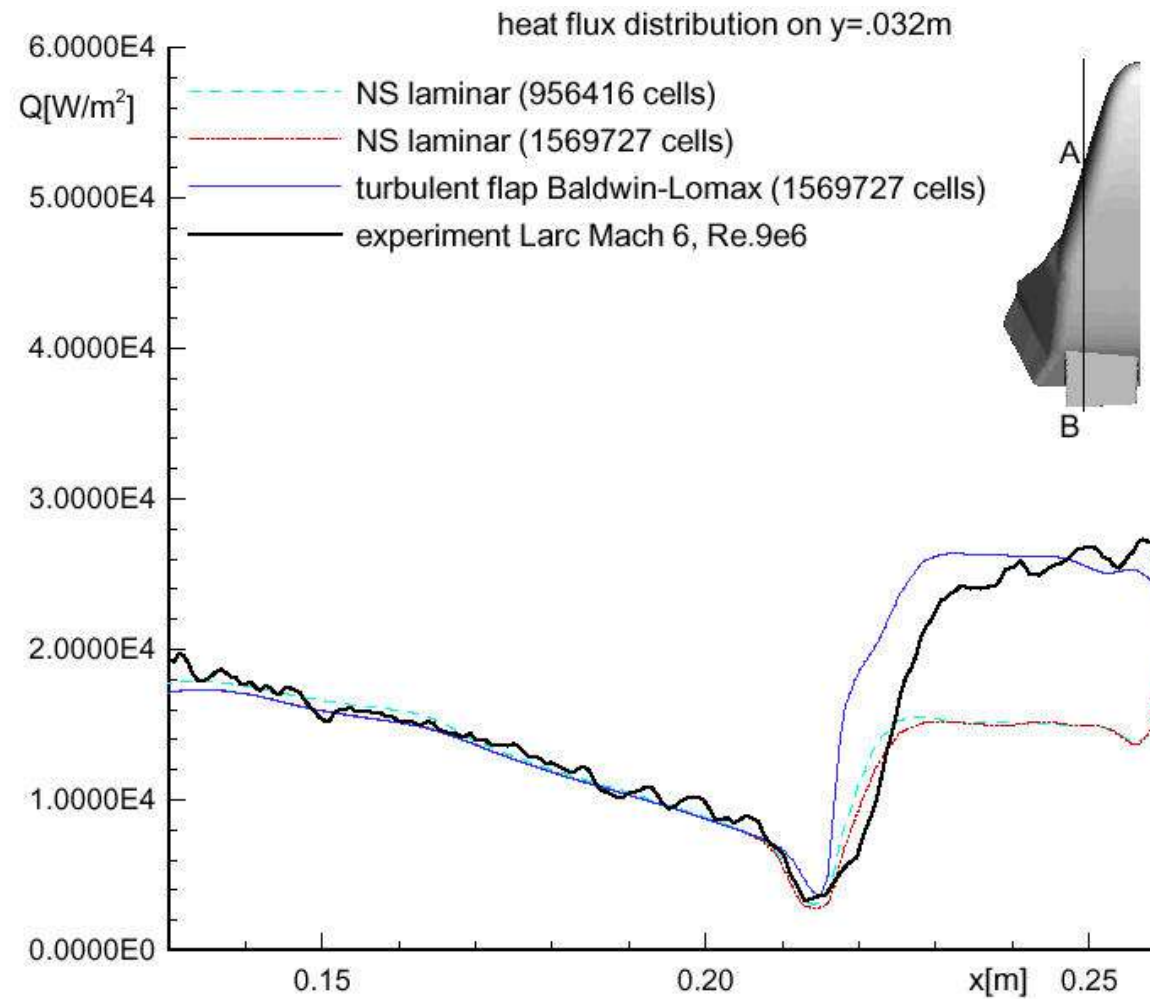
## F4 Nozzle Free Stream Rebuilding



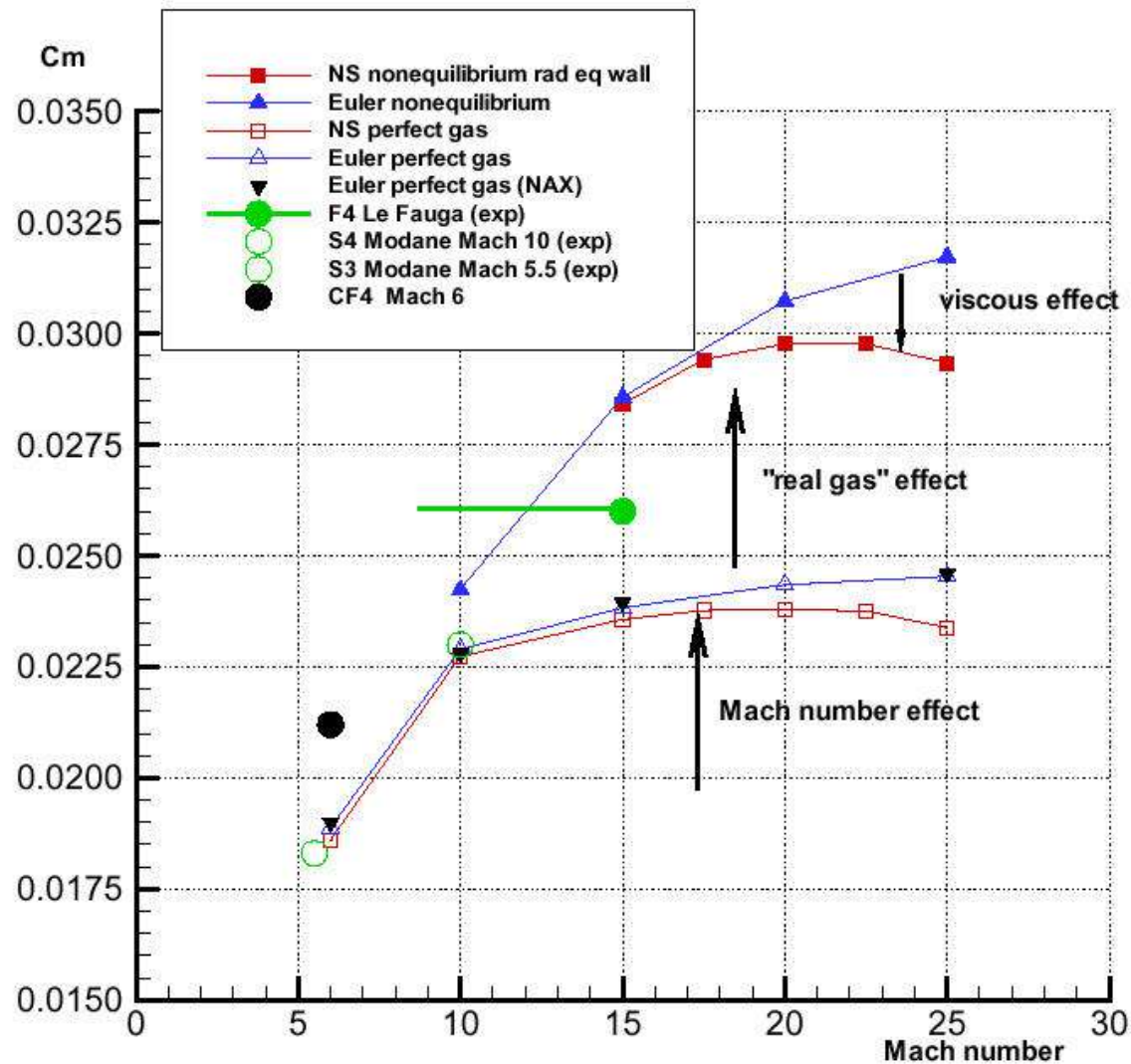
## X38 Heat Flux at M=6 at LARC



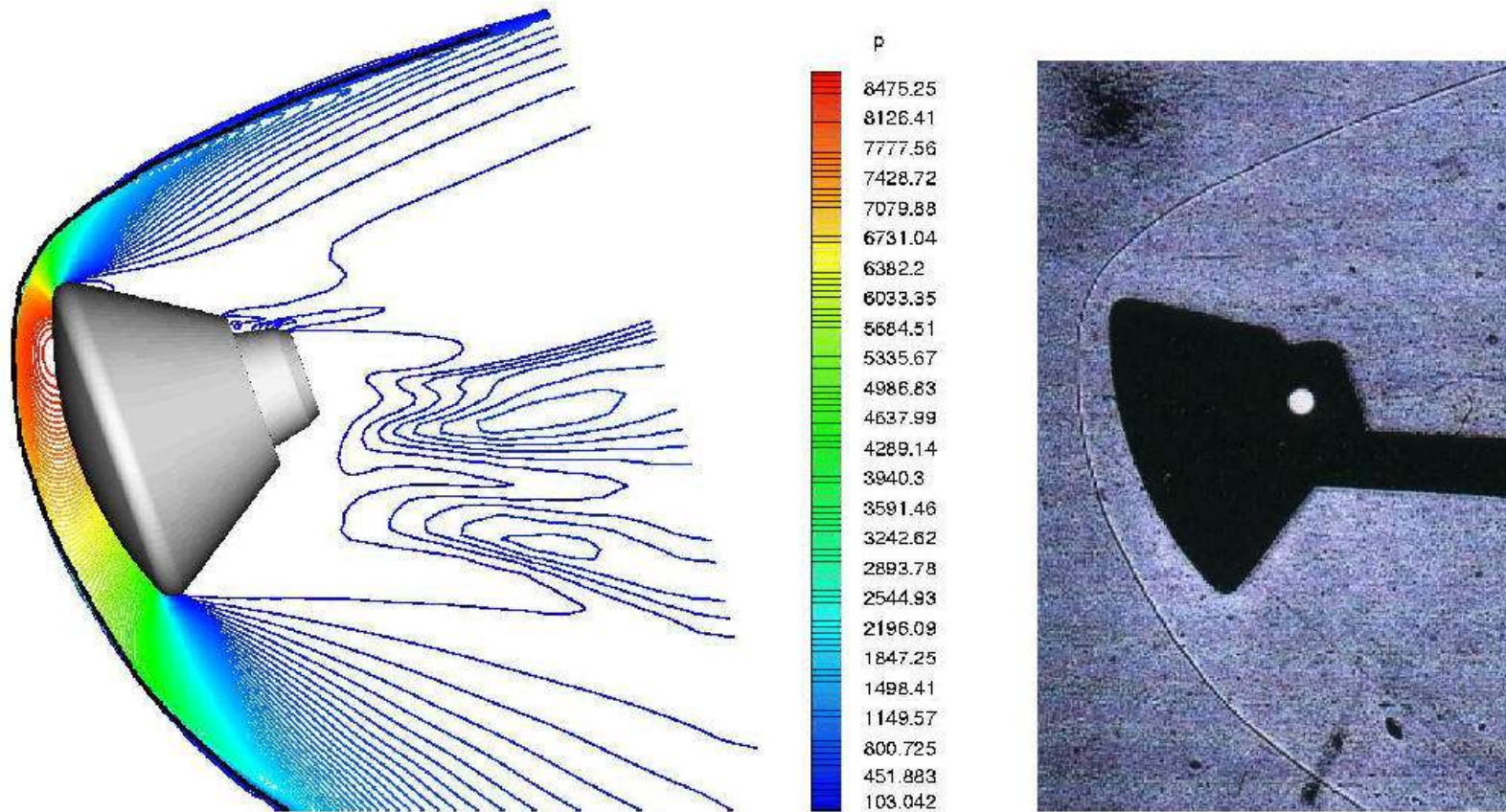
## X38 Flap Heating



## X38 Trimming



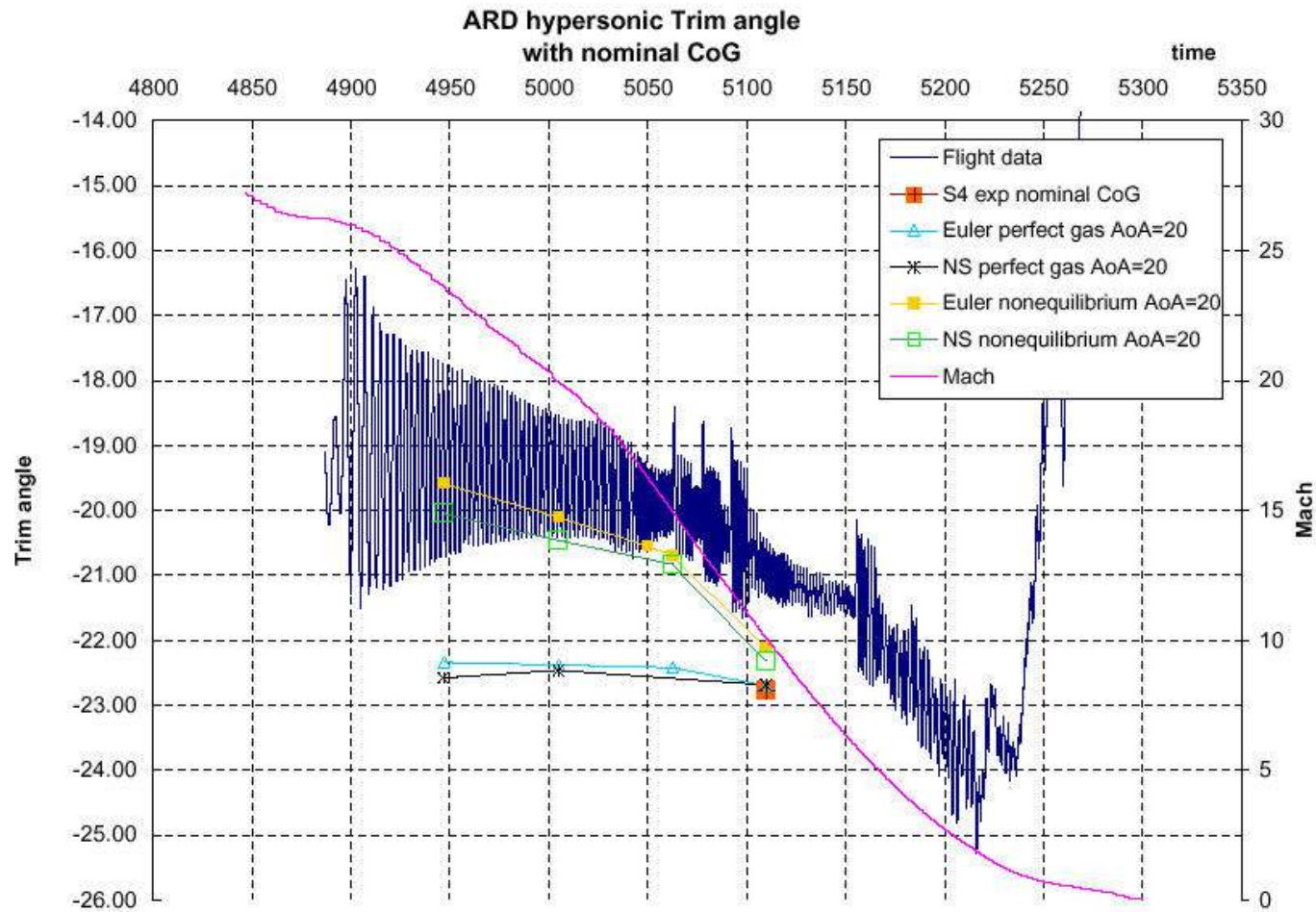
## ARD ONERA S4



(a) Pressure contour lines. The shock location of the schlieren picture is included.

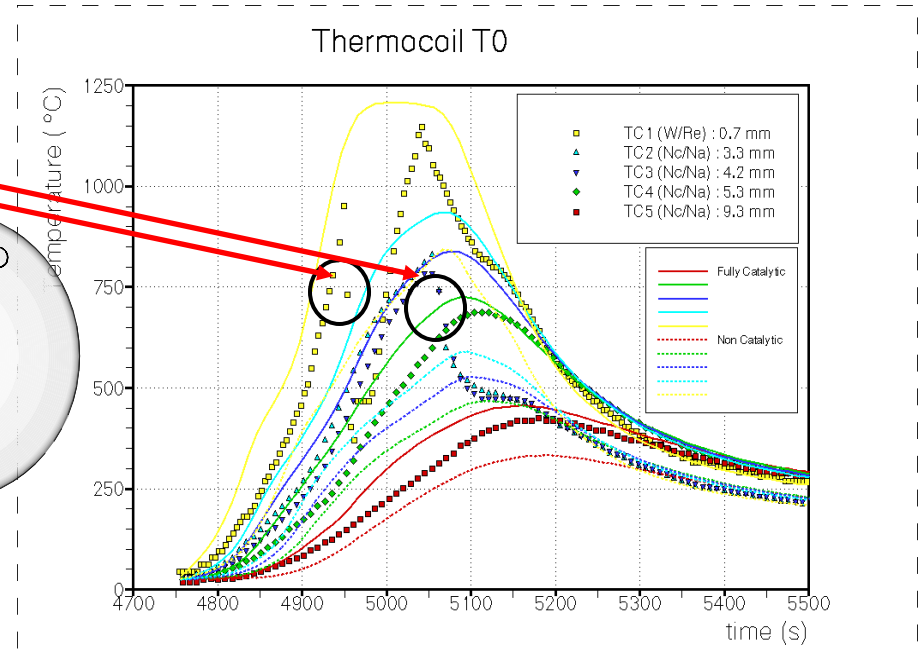
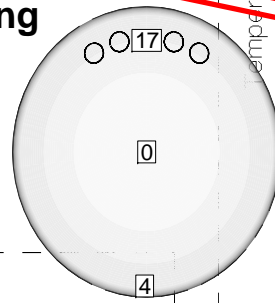
(b) Schlieren graph.

# ARD Trimming

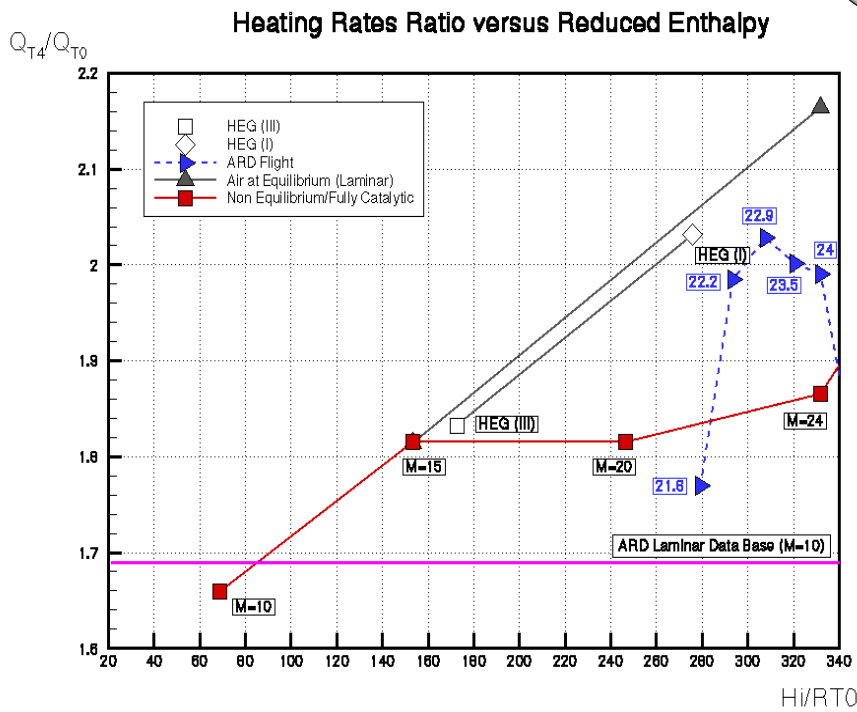


**Flight Temperature Measurement**  
**Front shield : thermocouples dysfunctioning**  
**at about 700-800°C**

**Heating Rate Extraction**  
**Inverse Method**



**Real Gas Effects on Tore Peak heating for ARD**



Courtesy EADS

# IN FLIGHT EXPERIMENTATION STRATEGY

## 1. FULL SCALE 1 FLIGHT :

- e.g. - SHUTTLE, BOURANE, APOLLO, SHENZHOU, ARIANE 5, HUYGENS
- HOPE, HERMES, OSP
  - HERCULES, SOCRATES

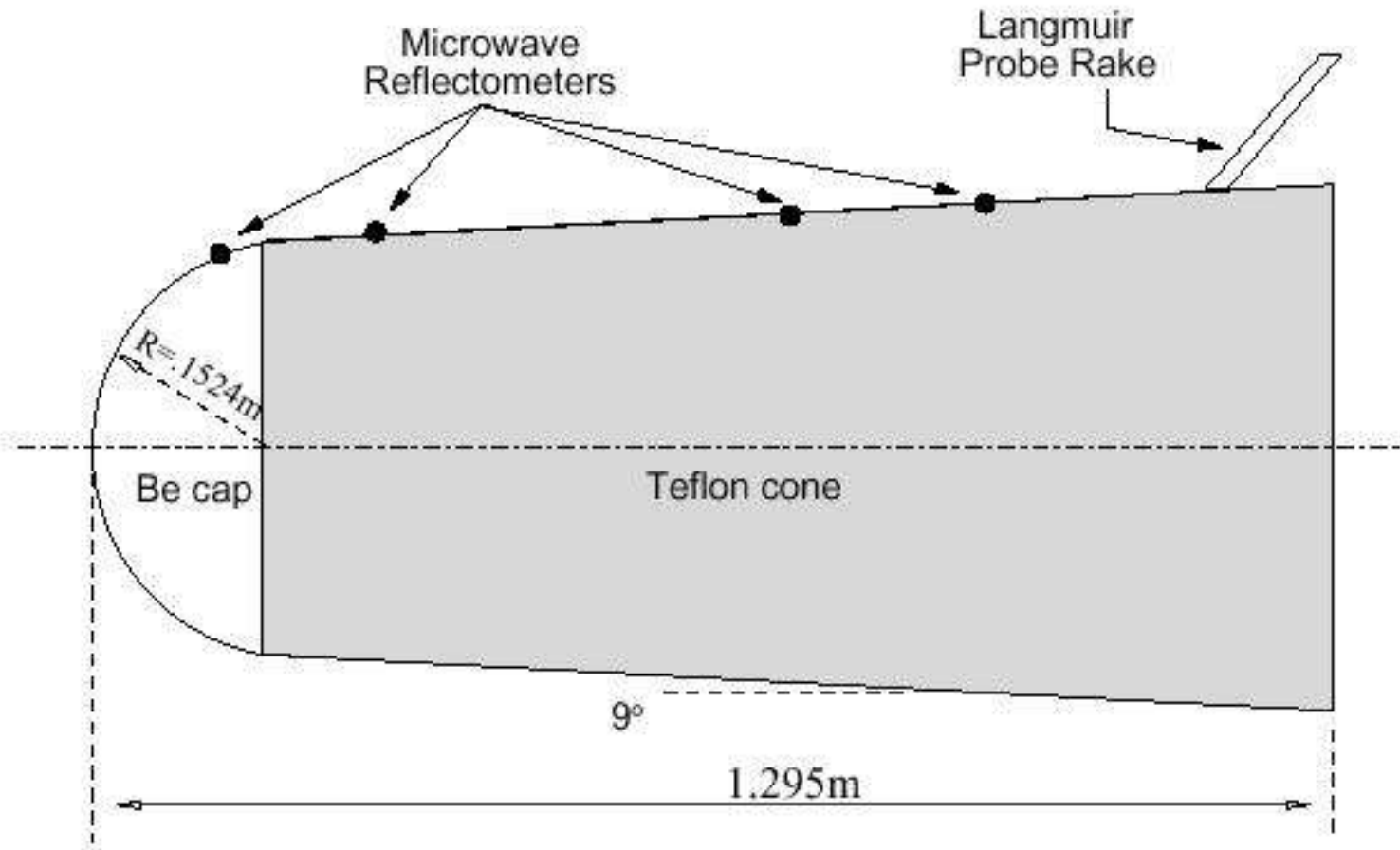
## 2. EXPERIMENTAL DEMONSTRATOR VEHICLES :

- e.g. - X23, X24, X38, AS201, AS202, APOLLO 4,6 ARD,
- BOR4 for TPS ; BOR5 for GNC;
  - OREX, HYFLEX for TPS ; ALFEX for GNC
  - MAIA, PHOENIX 1 and 2 for GNC
  - FLPP IXV ( PRE-X – USV )

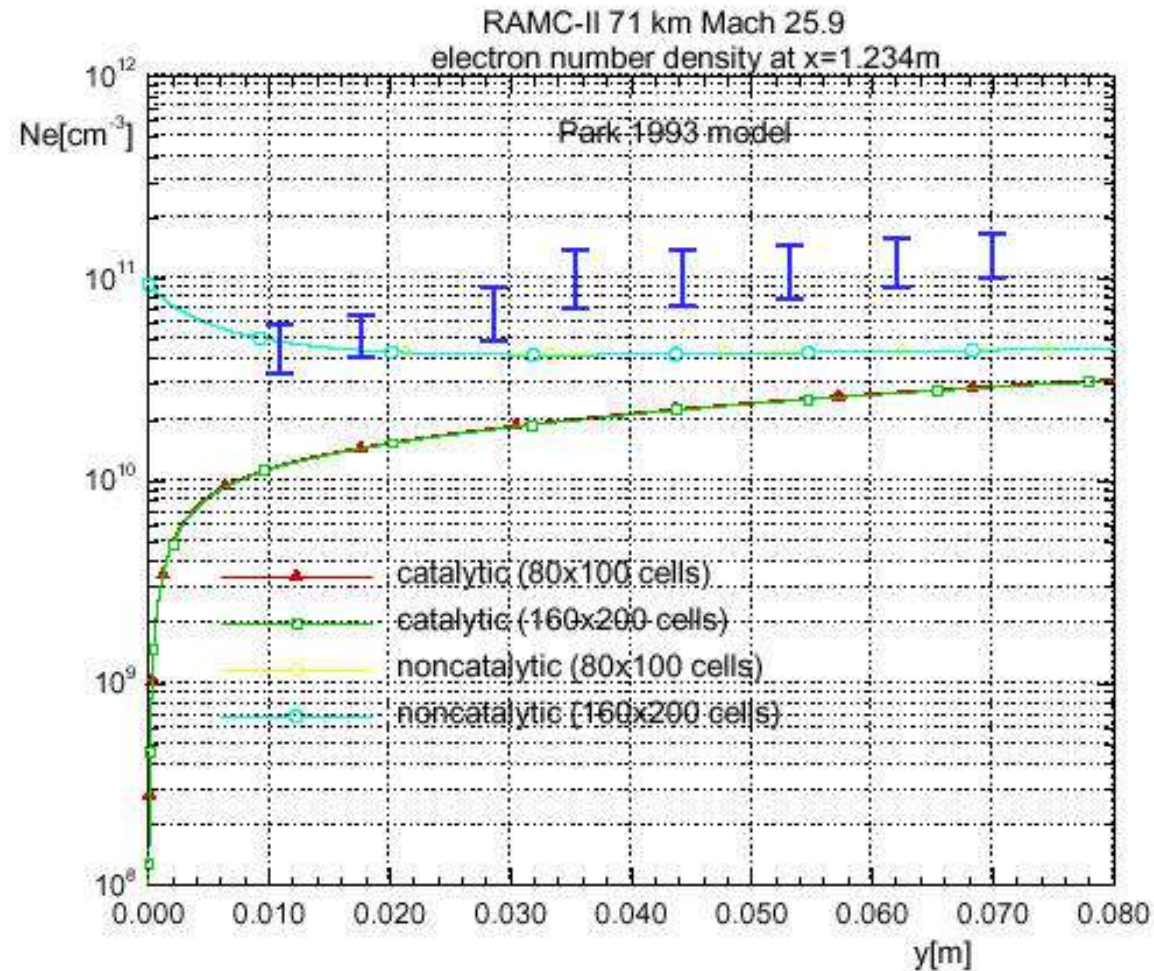
## 3. IN FLIGHT RESEARCH VEHICLES

- e.g. - SHARP B1, B2 FLIGHTS, HYSHOT, X43,
- IRDT, PAET, RAMC, FIRE
  - MIRKA, EXPRESS, SHEFEX, SFYFE
  - EXPERT

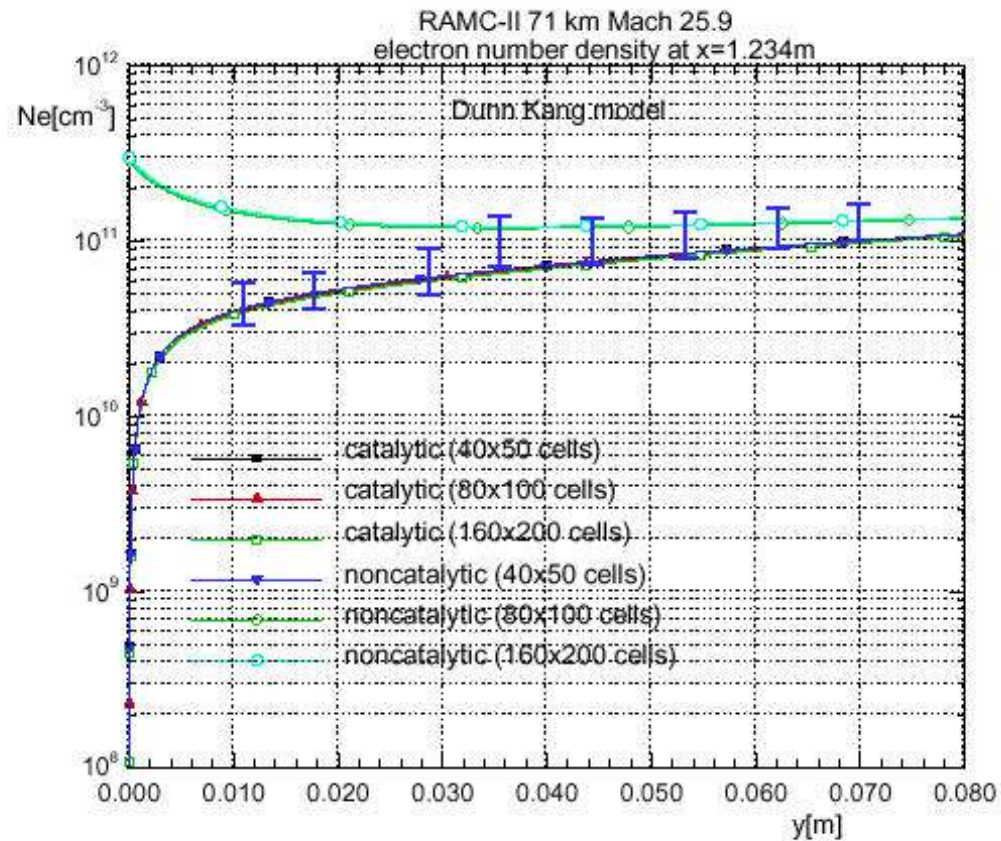
## RAMC flight test



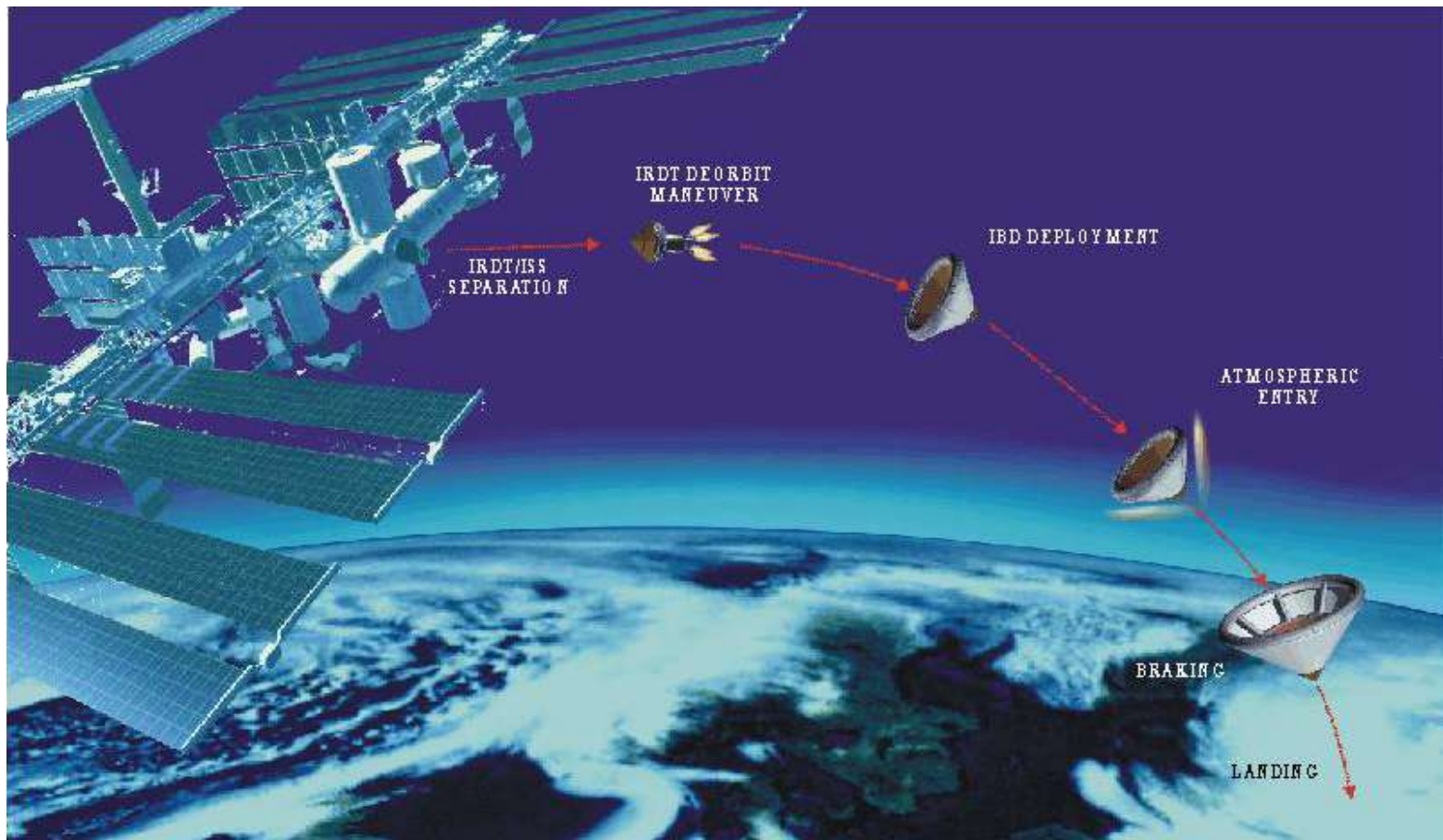
# RAMC flight test



# RAMC flight test



# IRDT future reentry capsule for rapid recovery from ISS



## MIRKA



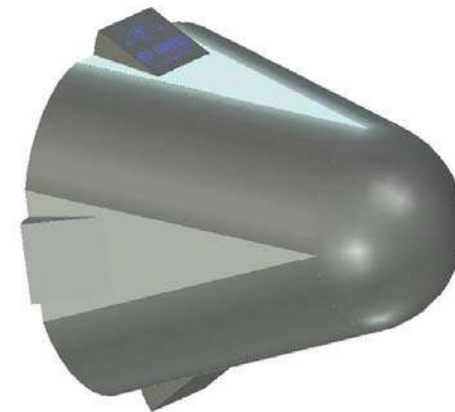
Spherical capsule to test innovative Surface Protected Ablator thermal protection

## EXPRESS



Capsule to test material samples and instrumentation for reentry

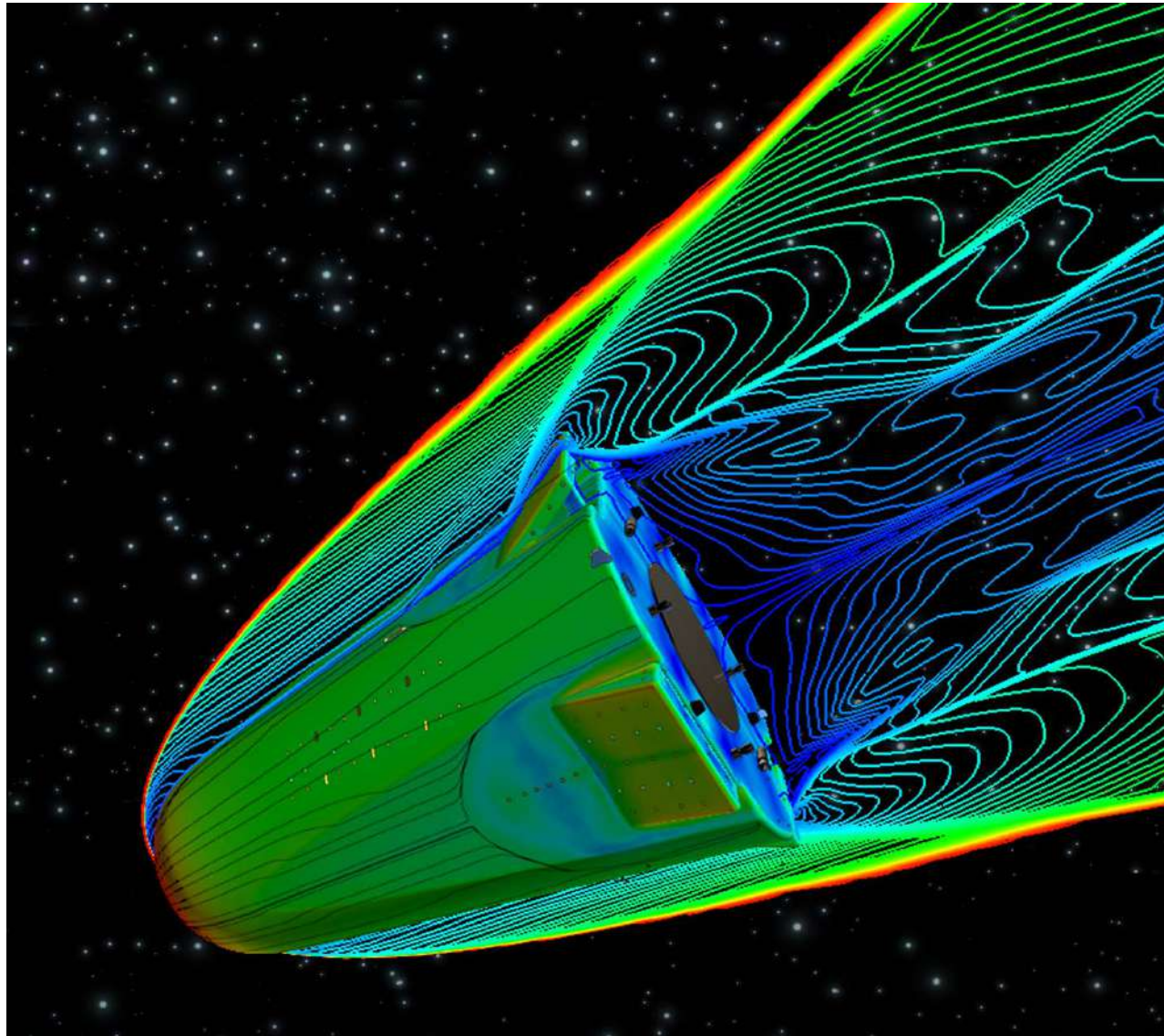
## EXPERT



Capsule to test ATD phenomena and instrumentation for reentry

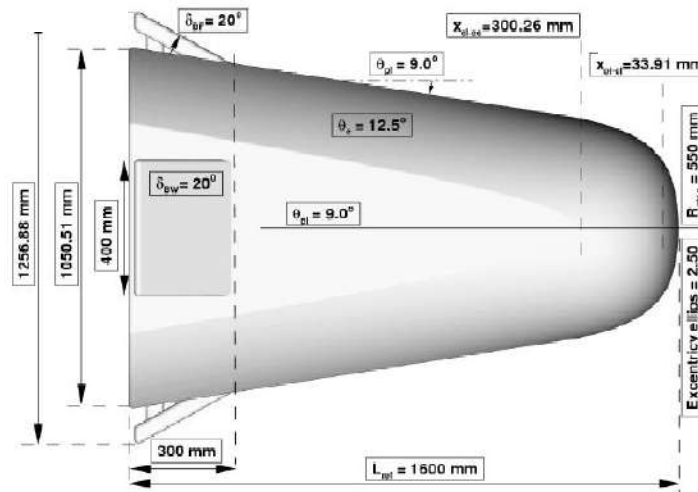
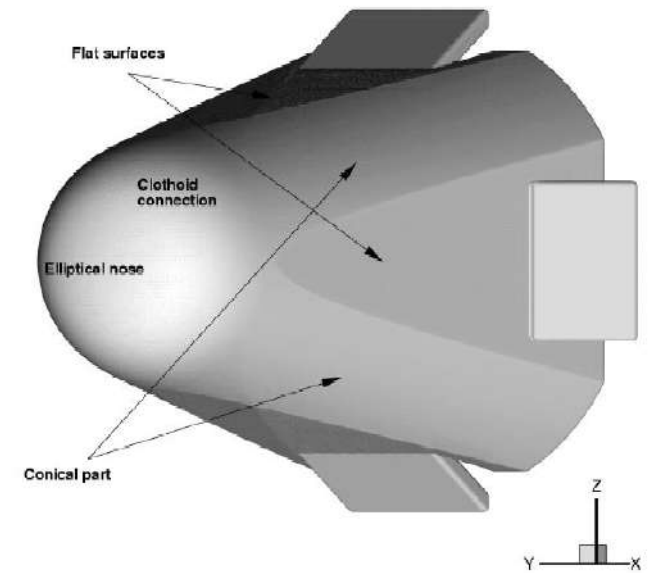
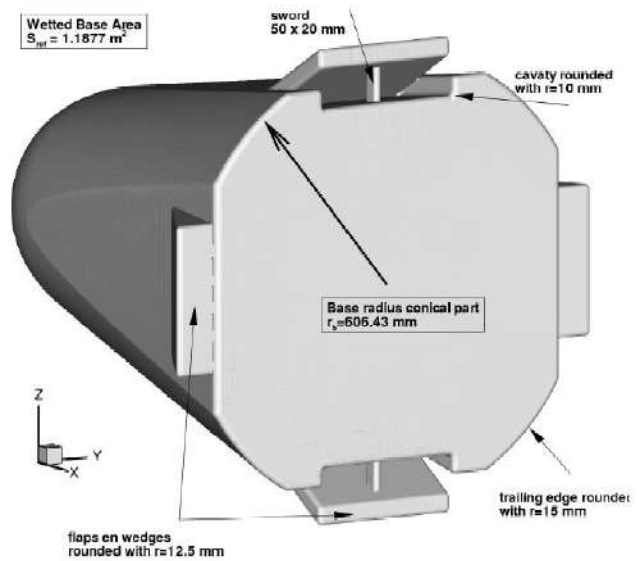
## Course Roadmap

- **Flight Experimentation Logic**
- **Motivation for in flight research**
- **EXPERT requirements**
- **Vehicle design and Flight instrumentation**
- **Conclusions**

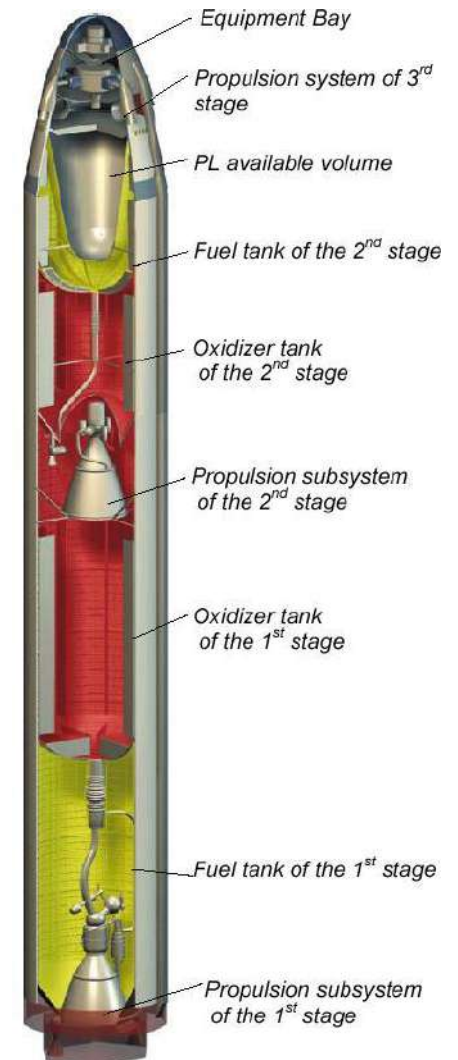


## **OBJECTIVES EXPERT**

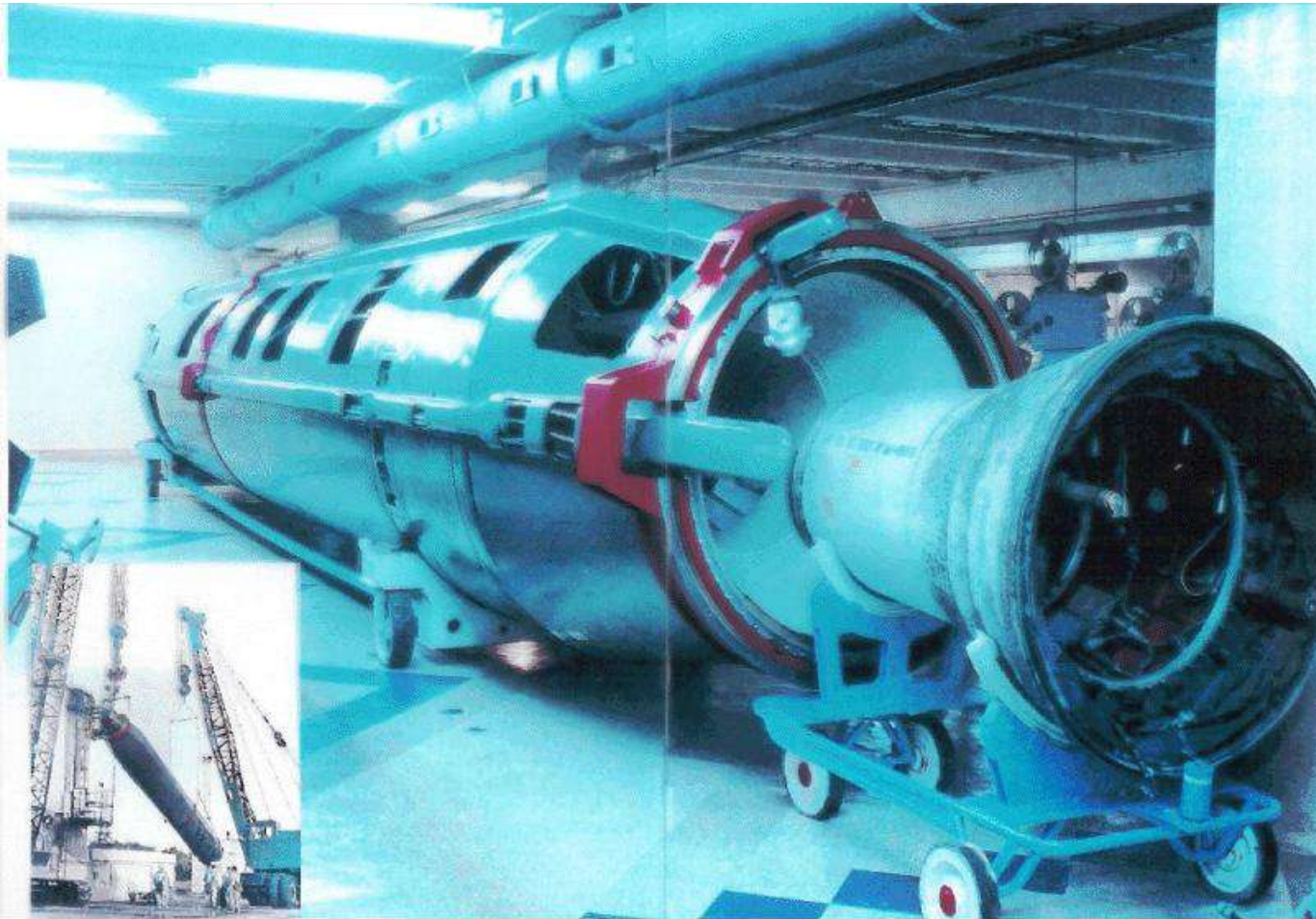
- 1) **DESIGN, MANUFACTURE AND PERFORM MULTIPLE FLIGHTS FOR LOW COST IN-FLIGHT RESEARCH USING GENERIC CONFIGURATIONS FOR THE STUDY OF CRITICAL AEROTHERMODYNAMIC PHENOMENA :**
  - **TRANSITION**
  - **SWBLI/REAL GAS EFFECTS**
  - **LOCAL ATD IN FLAP REGION**
  - **CATALYSIS**
  - **BLACKOUT**
  
- 2) **FOCUS ON ATD PREDICTION CAPABILITIES INCLUDING WINDTUNNEL TO FLIGHT EXTRAPOLATION ACTIVITIES AND QUALITY OF FLIGHT MEASUREMENT TECHNIQUES THEMSELVES.**



## Volna Launch Vehicle



## Volan in Volna launcher



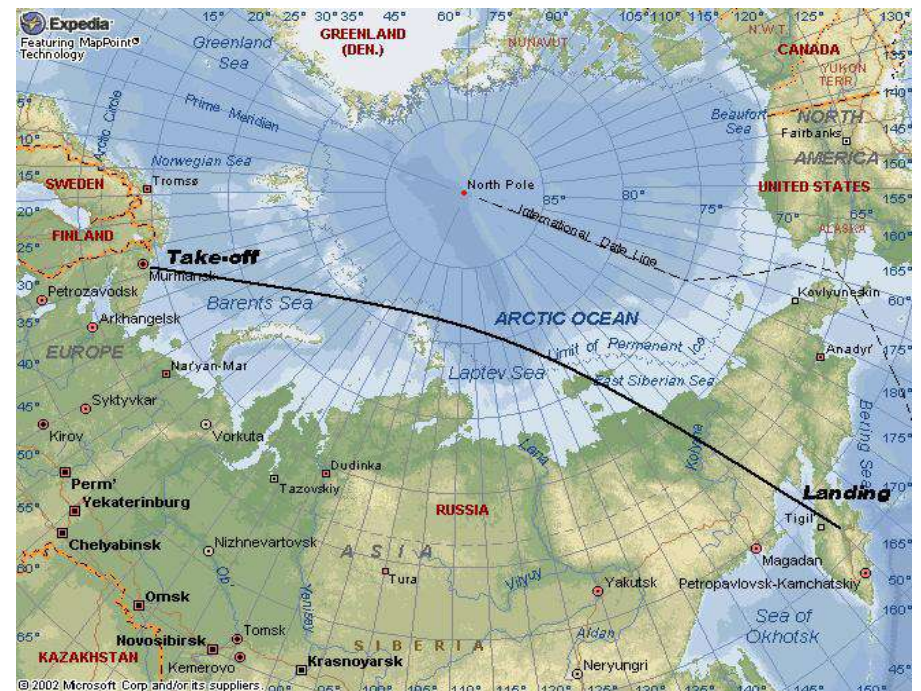
## Volna Submarine launched



## EXPERT mission ground tracks

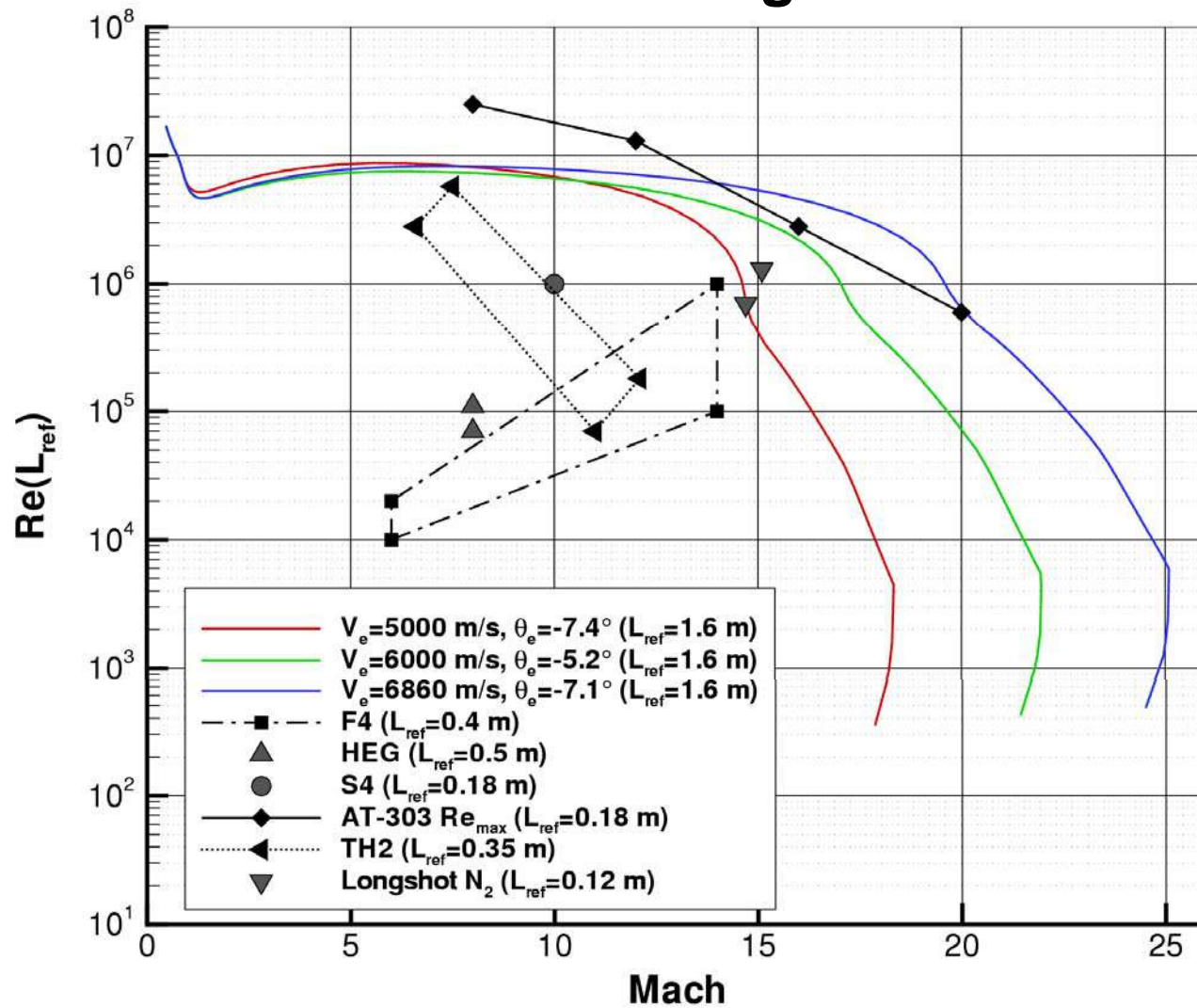


$V_e = 5.0$  and  $6.0$  km/s

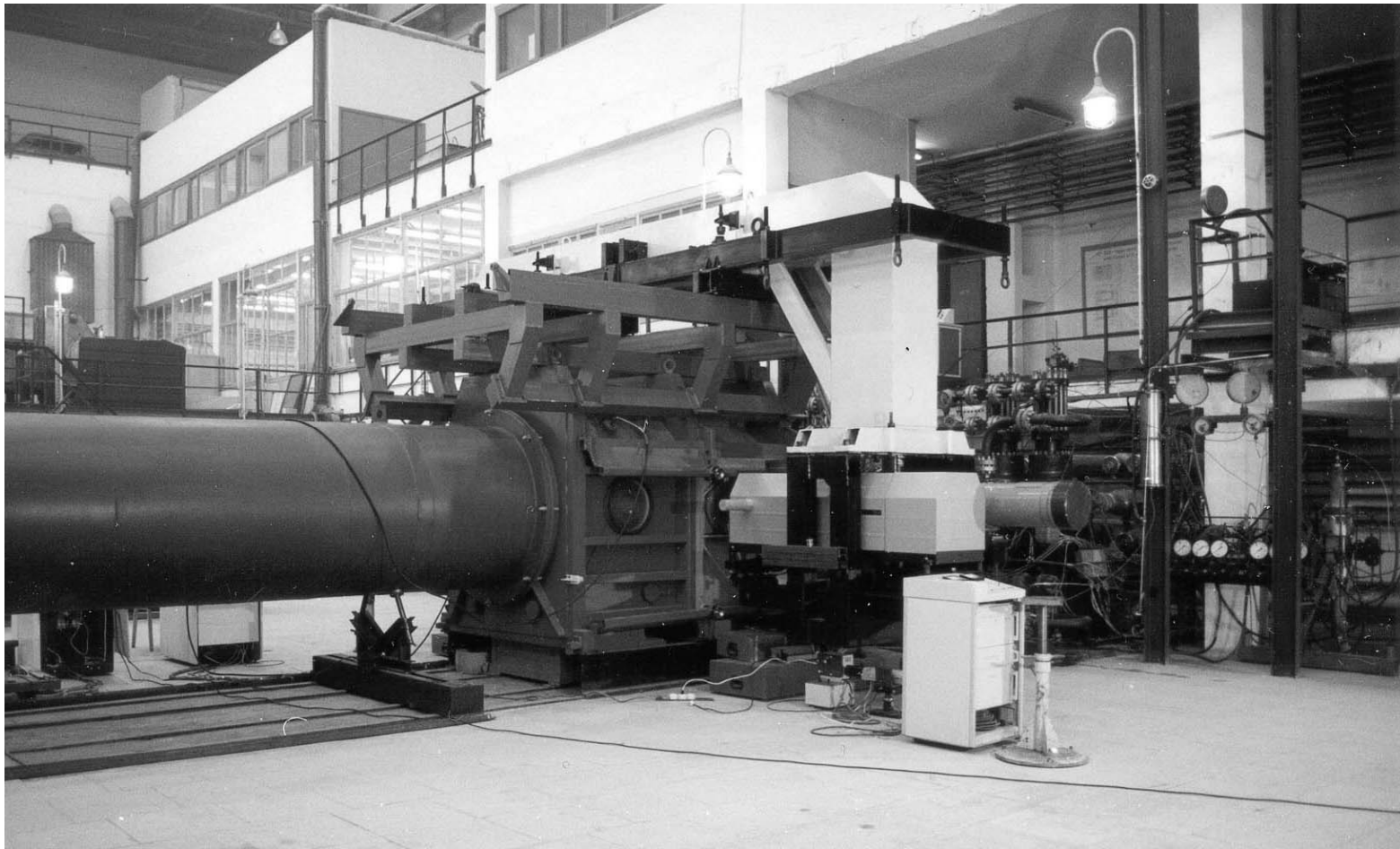


$V_e = 6.86$  km/s

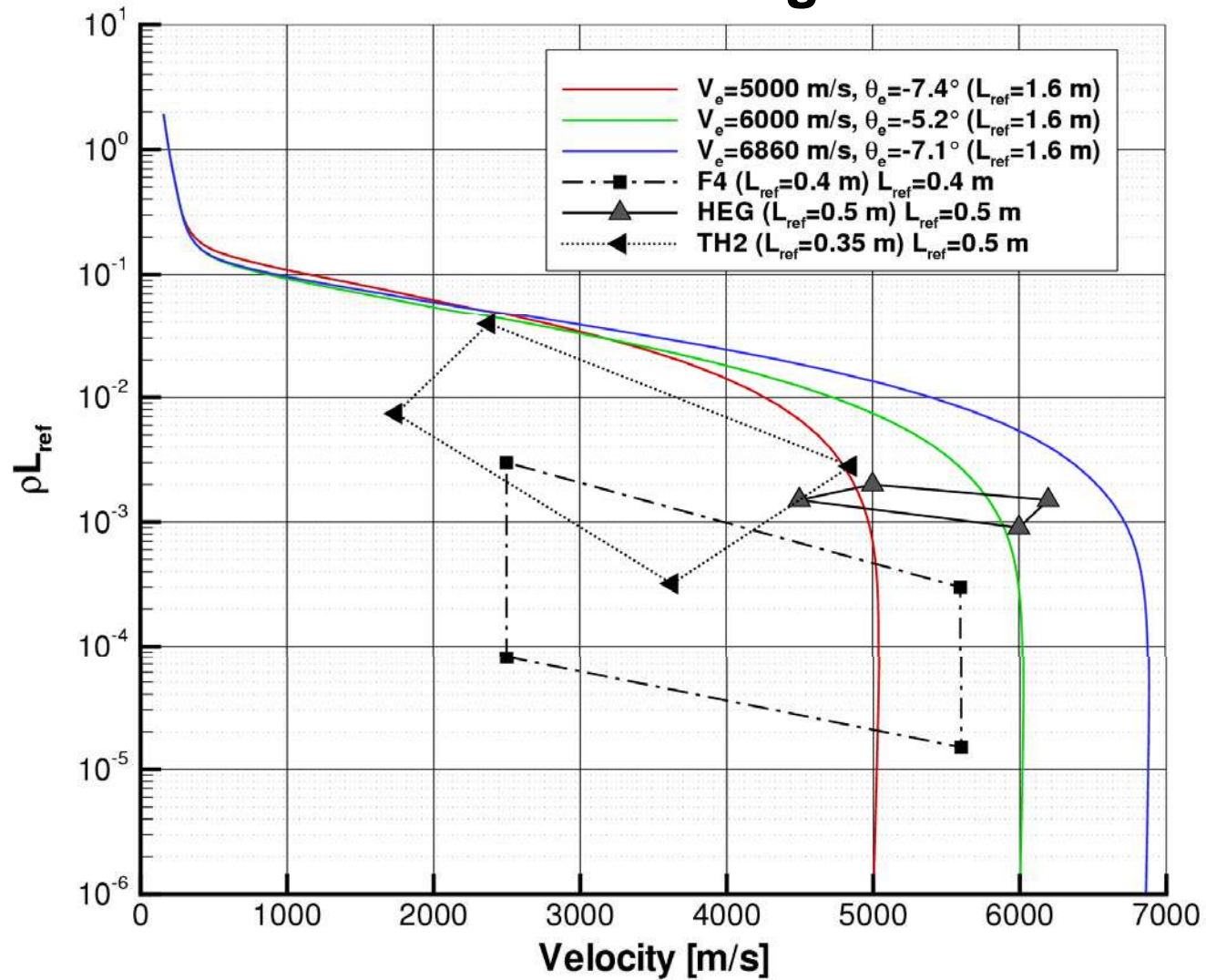
## Wind tunnel coverage EXPERT



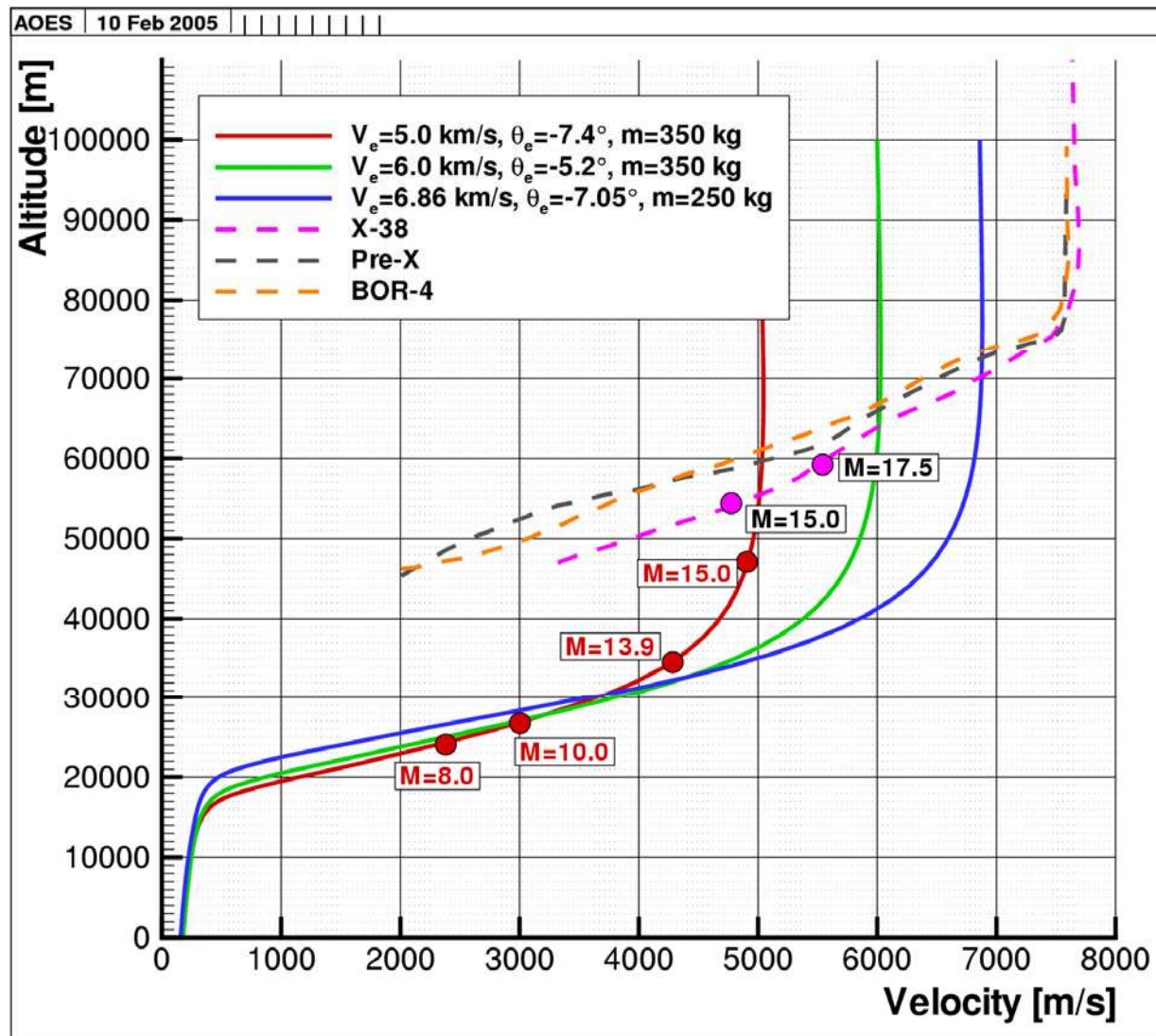
## ITAM's high-Re-# tunnel AT303



## Wind tunnel coverage EXPERT



# Lifting versus Ballistic

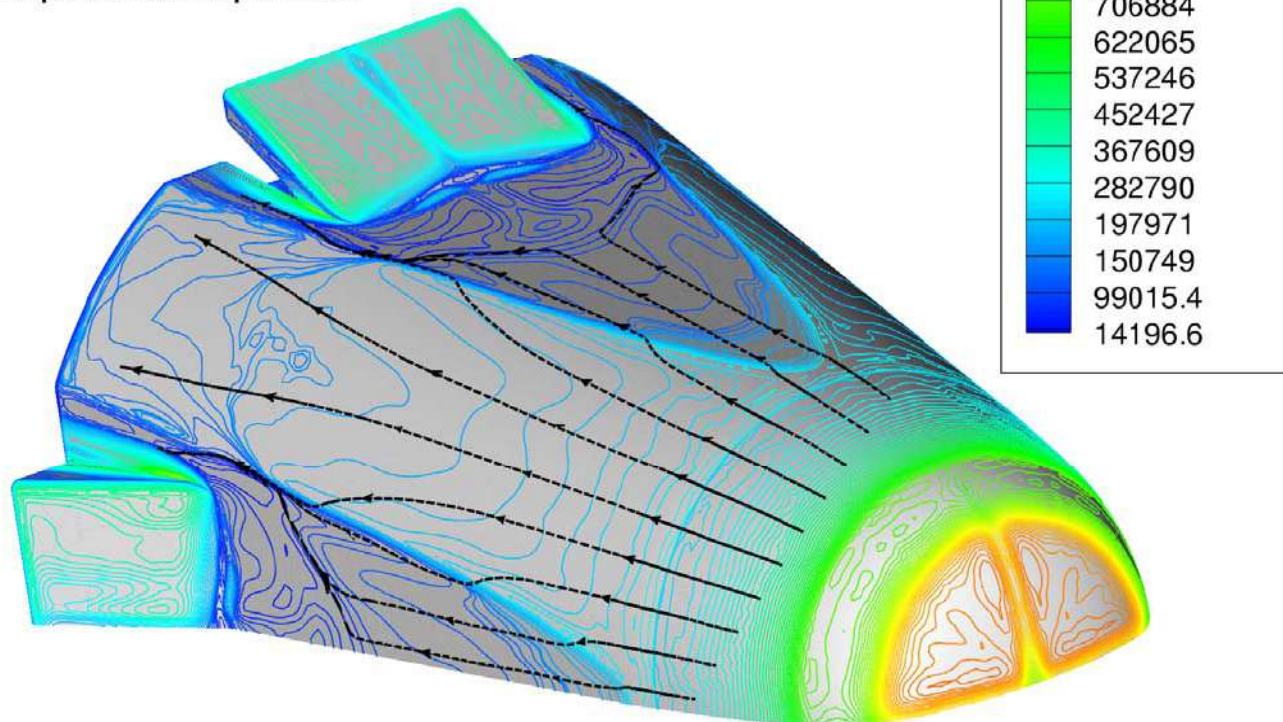
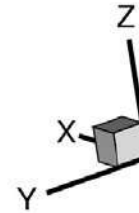


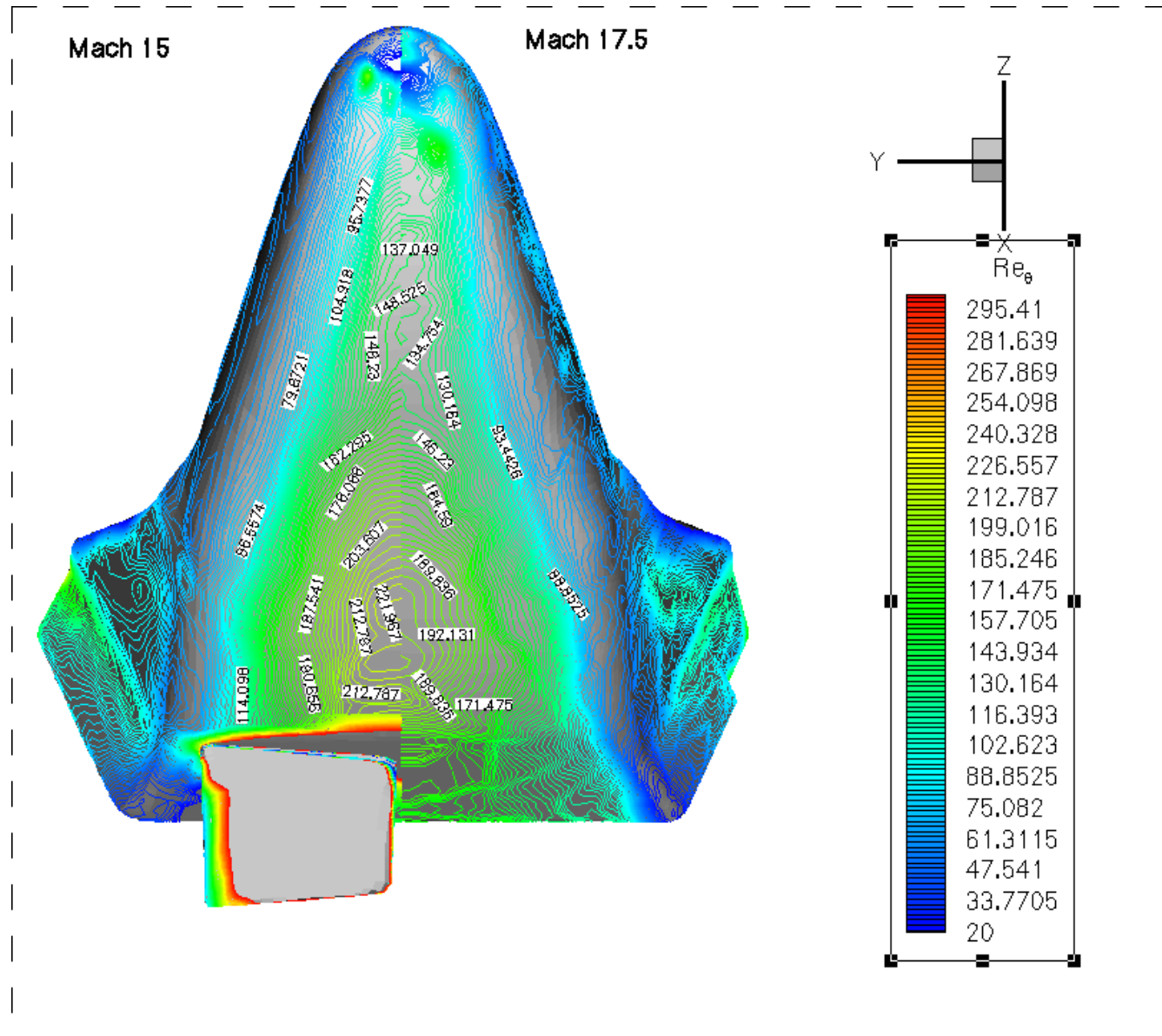
**P1:  $V_e=5.0$  km/s,  $\theta_e=-7.4$ ,  $m=360$  kg**

**$T_w$  C/SiC provided by DLR  
PC Steward**

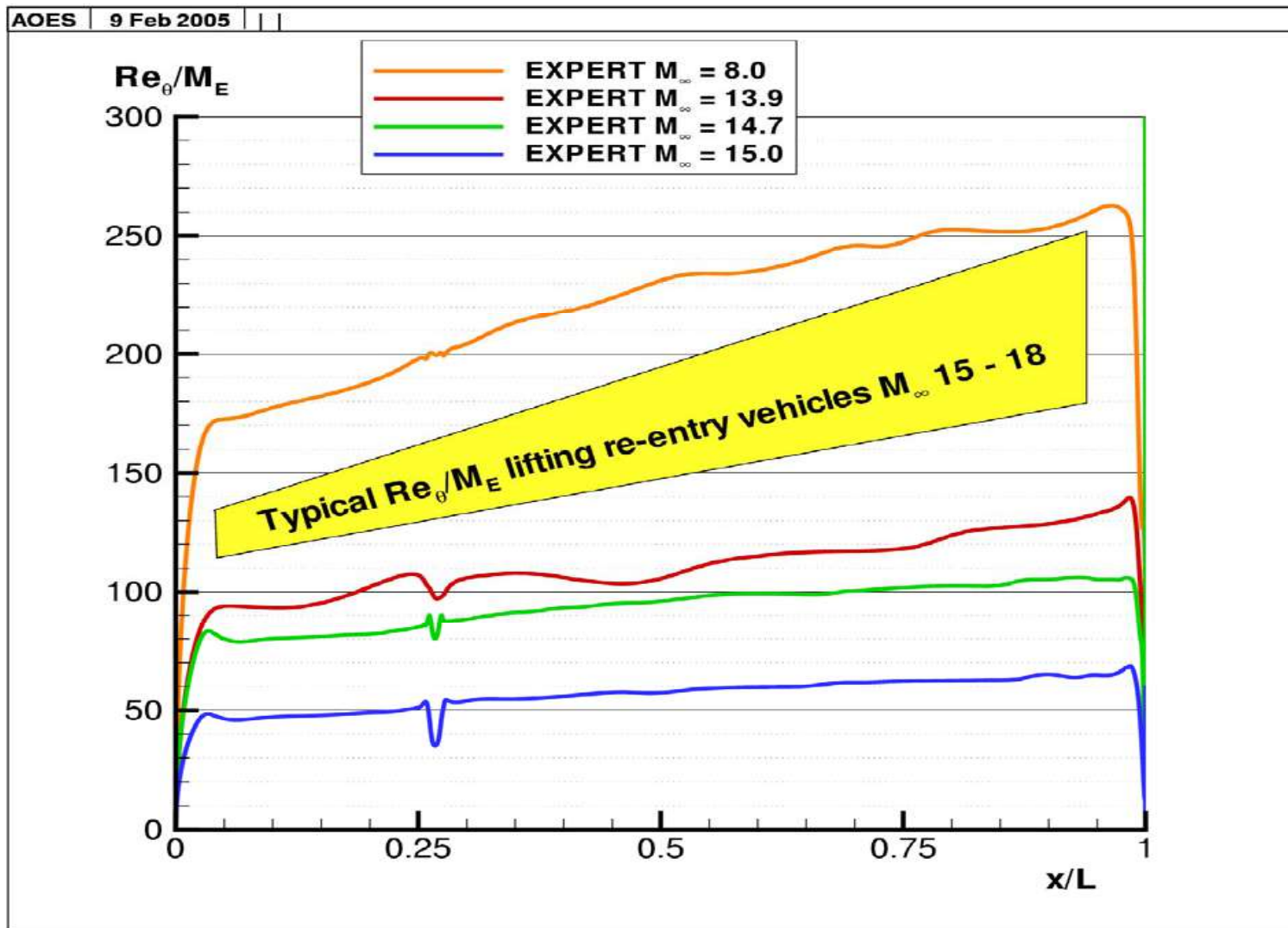
**$T_w$  PM1000 linear decreasing  
from 1450 K to 1350 K  
PC  $\gamma$  exponential decreasing  
from 4.0% to 1.0%**

**Flaps radiative equilibrium**





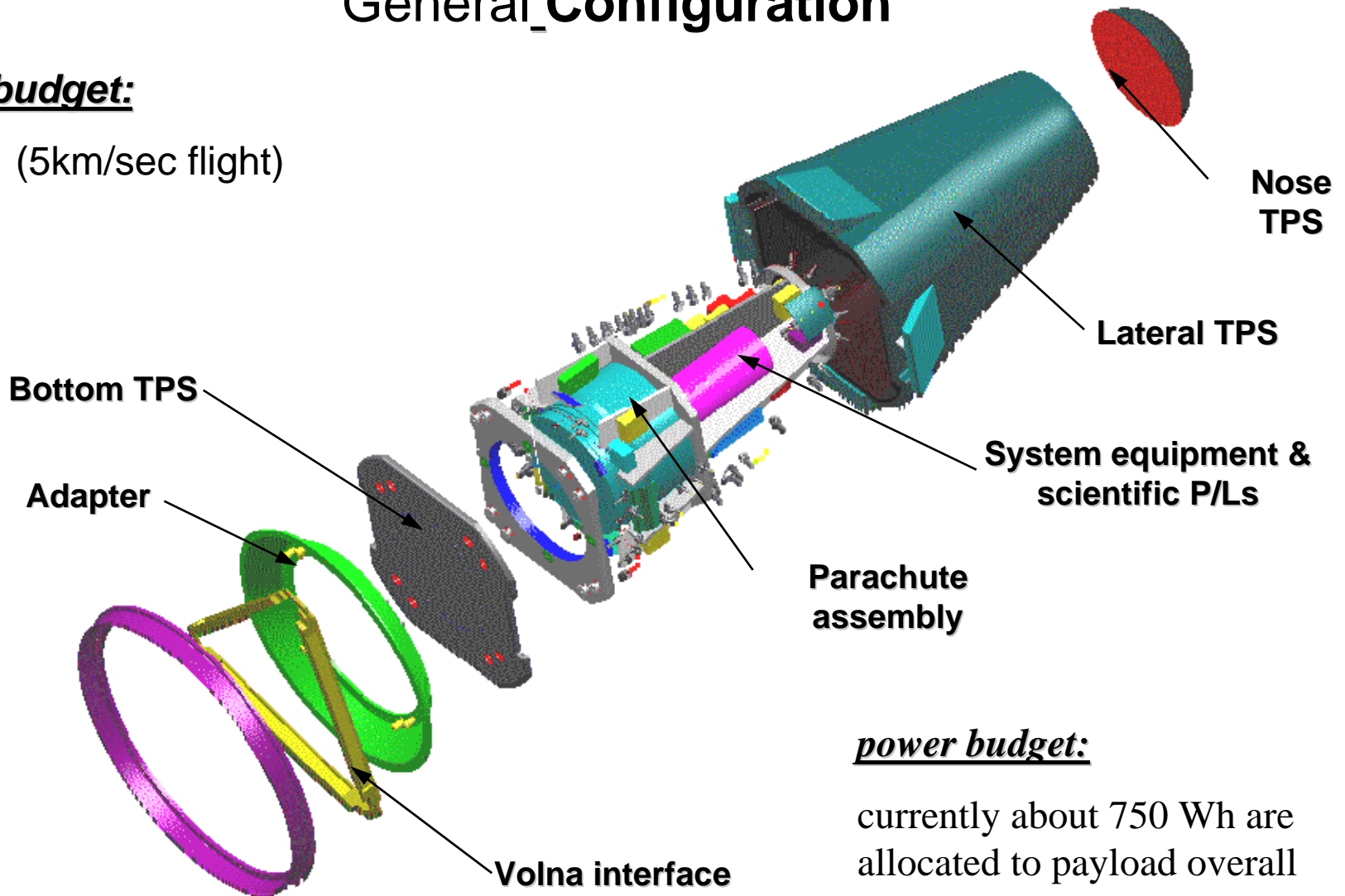
# Local Parameter for Transition Laminar to Turbulent



## General Configuration

**mass budget:**

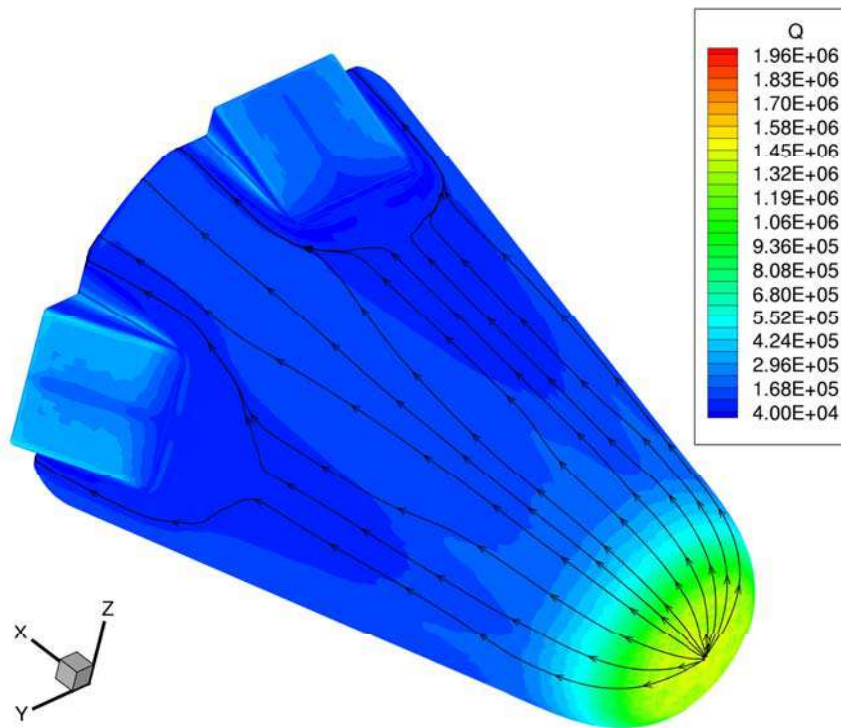
360 kg (5km/sec flight)



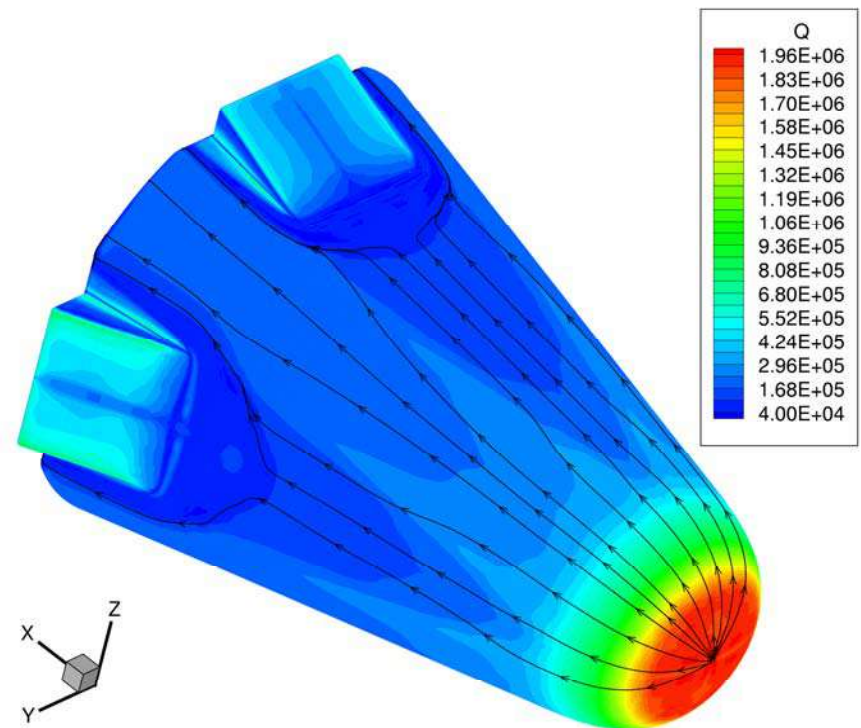
**power budget:**

currently about 750 Wh are allocated to payload overall (for 30 min. active mission)

## Heat flux at peak heating for $V_e=6.0$ km/s

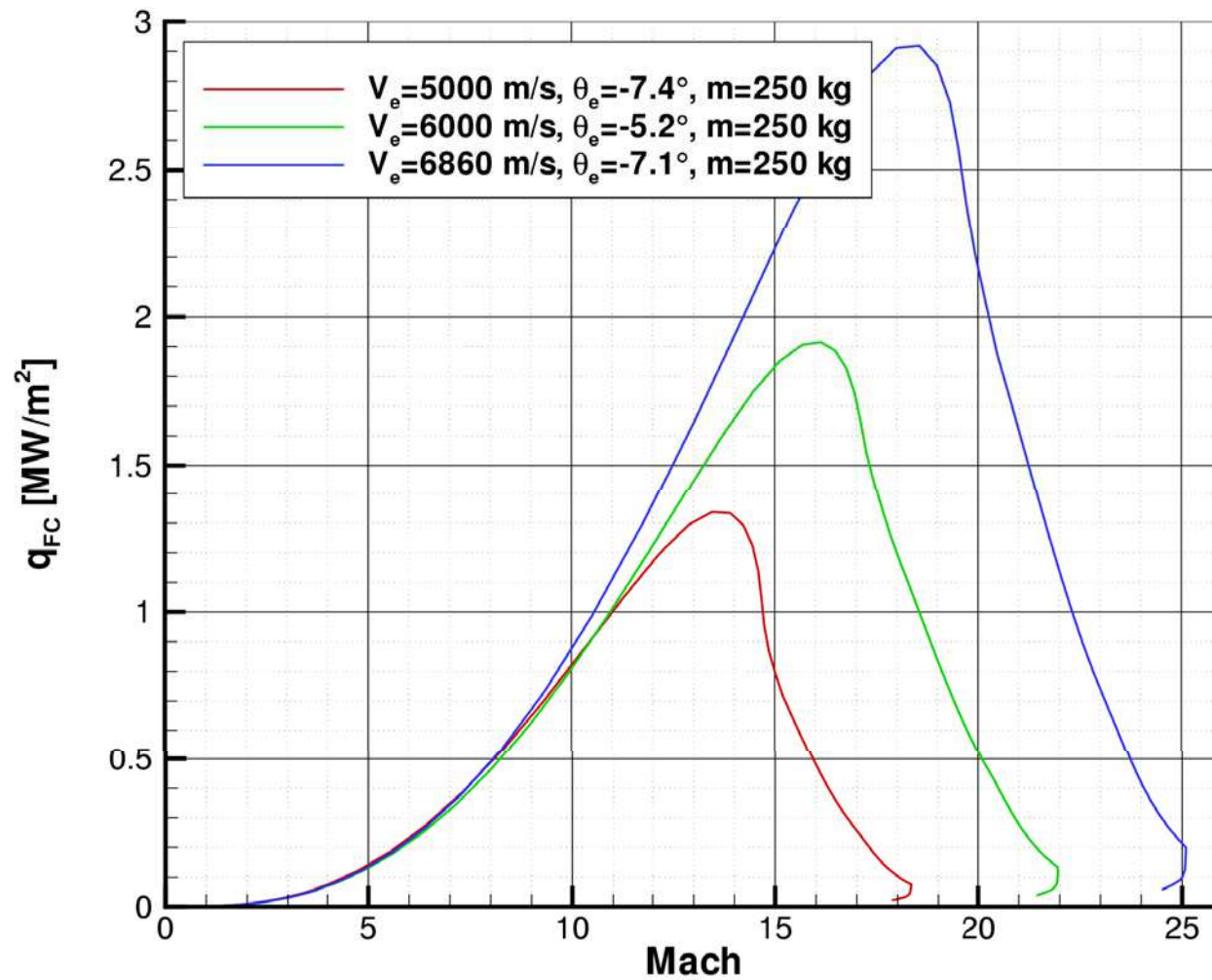


**Non-catalytic**

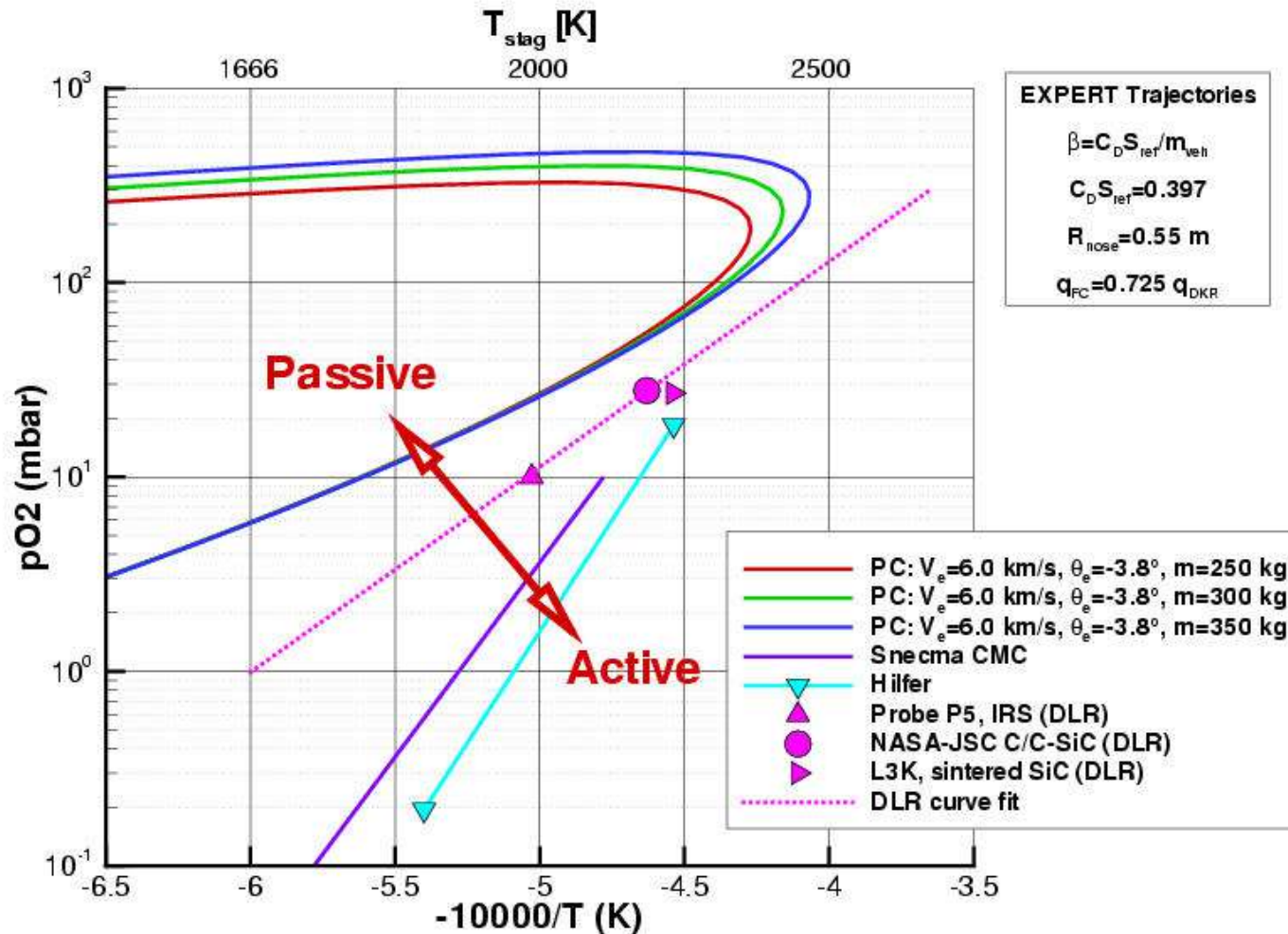


**Catalytic**

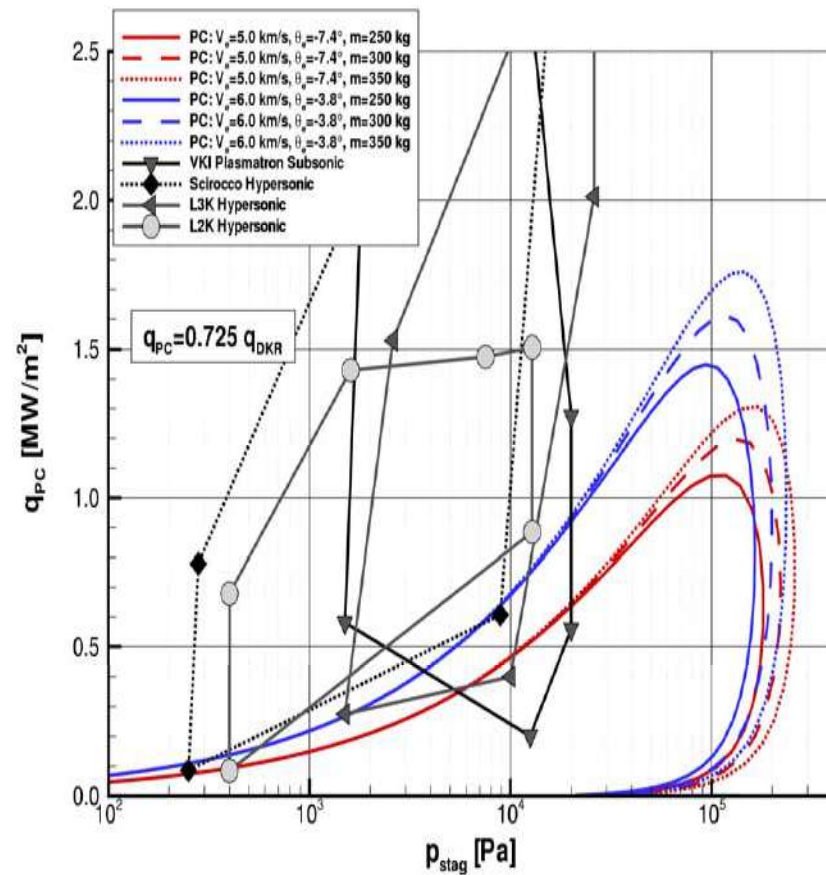
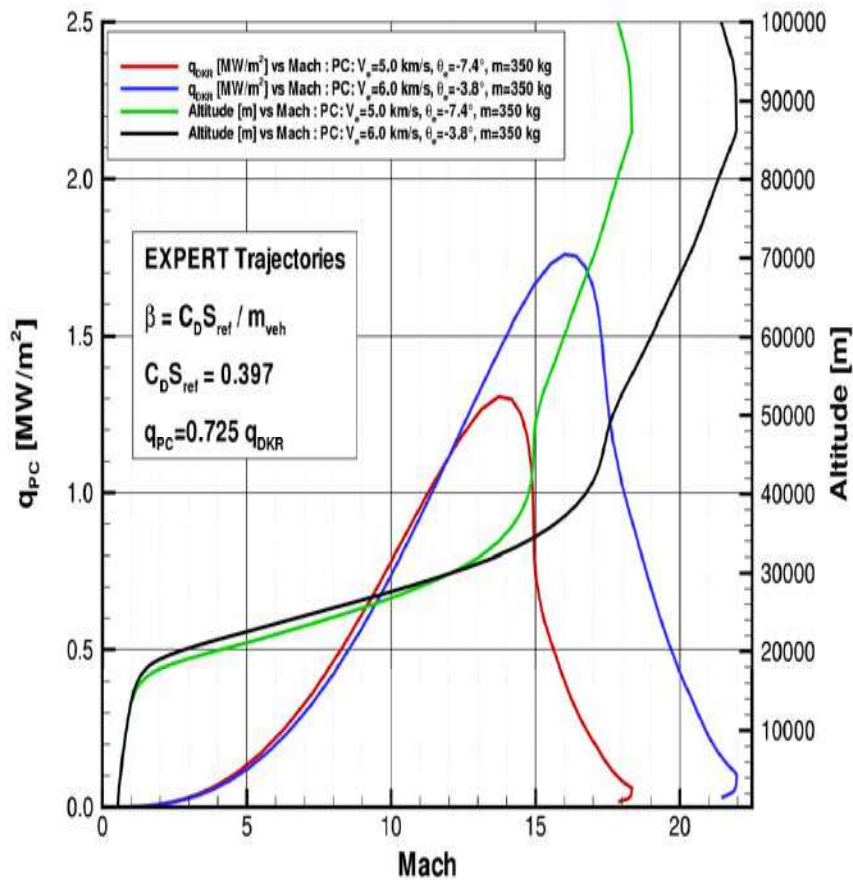
## Trajectory EXPERT



## EXPERT trajectory $V_e=6.0$ km/s



# EXPERT Trajectories Plasma facilities coverage





**ADS**

**TPS :**

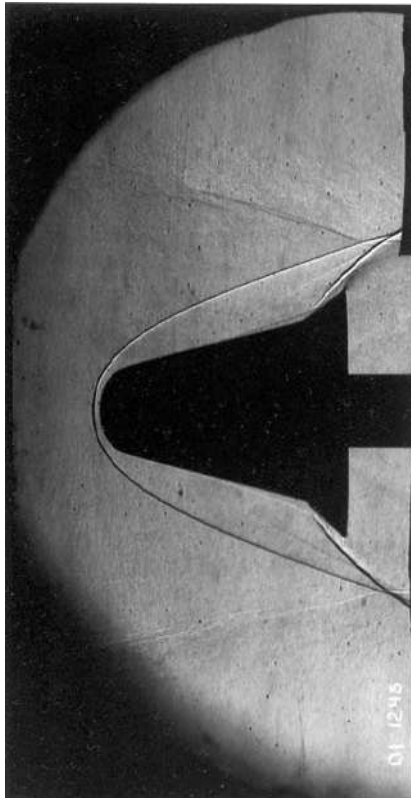
- Nose : C-SIC
- Cone : PM1000
- Flaps : C-SIC
- Base : FEI or Ti alloy

## Course Roadmap

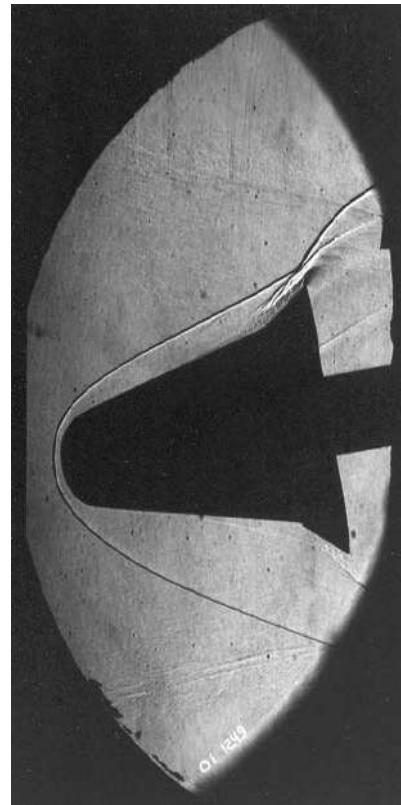
- **Flight Experimentation Logic**
- **Motivation for in flight research**
- **EXPERT requirements**
- **Vehicle design and Flight instrumentation**
- **Conclusions**

## VKI H3 Mach 6

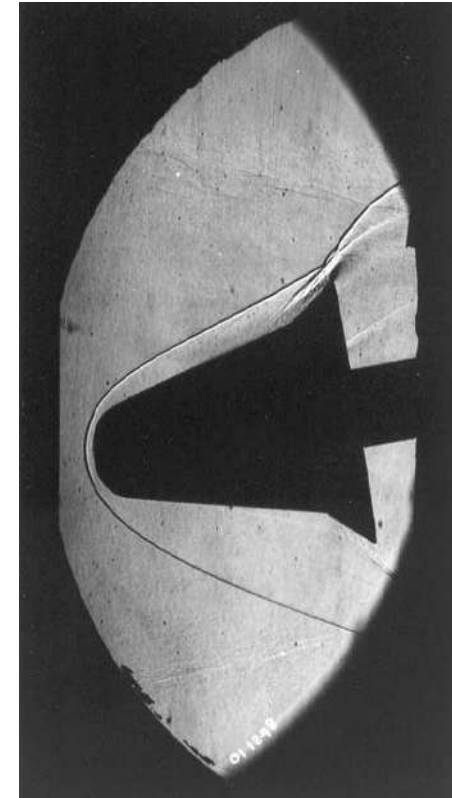
Pi=20 bars -  $\alpha=0^\circ$



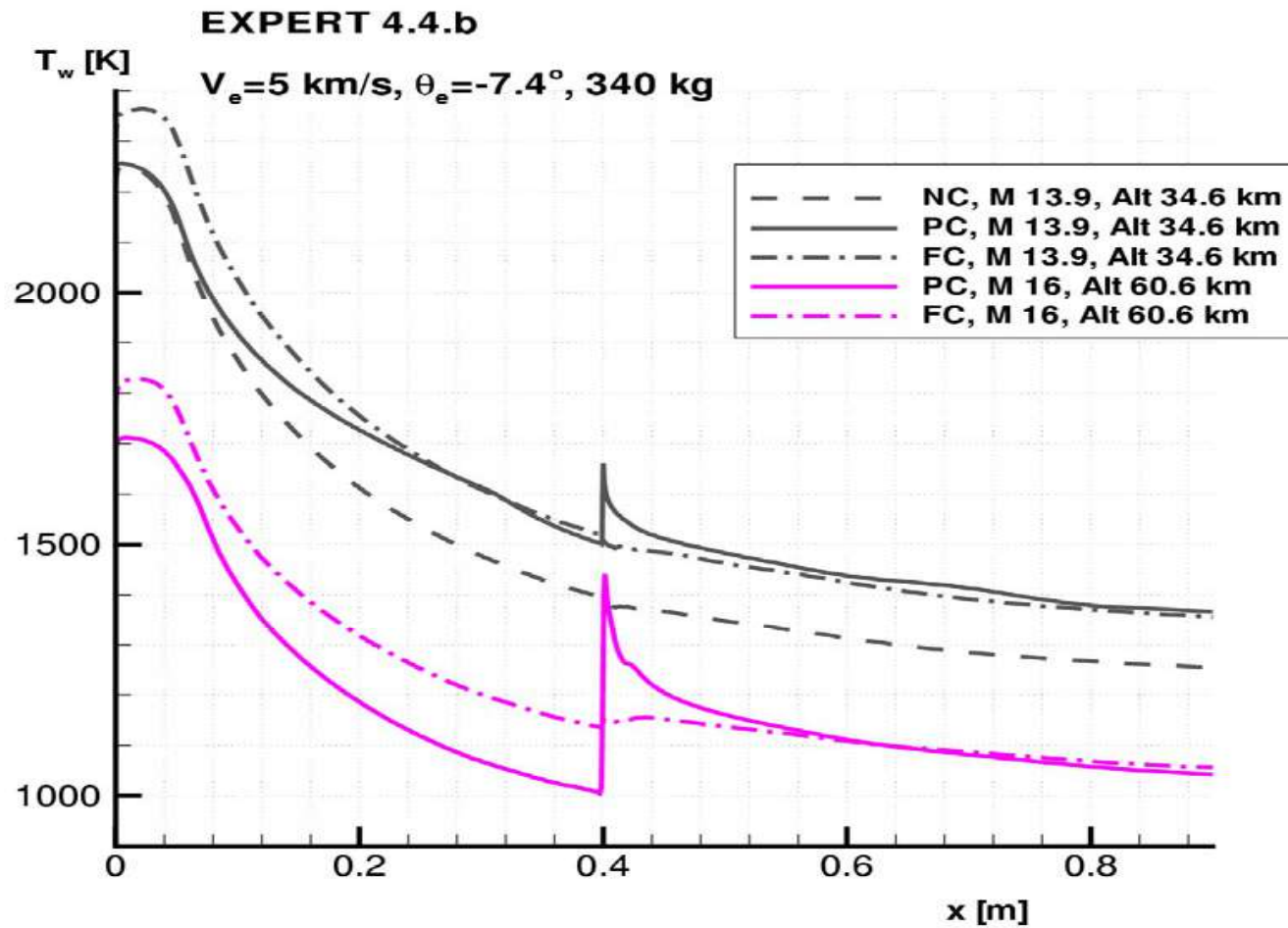
Pi=20 bars -  $\alpha=10^\circ$



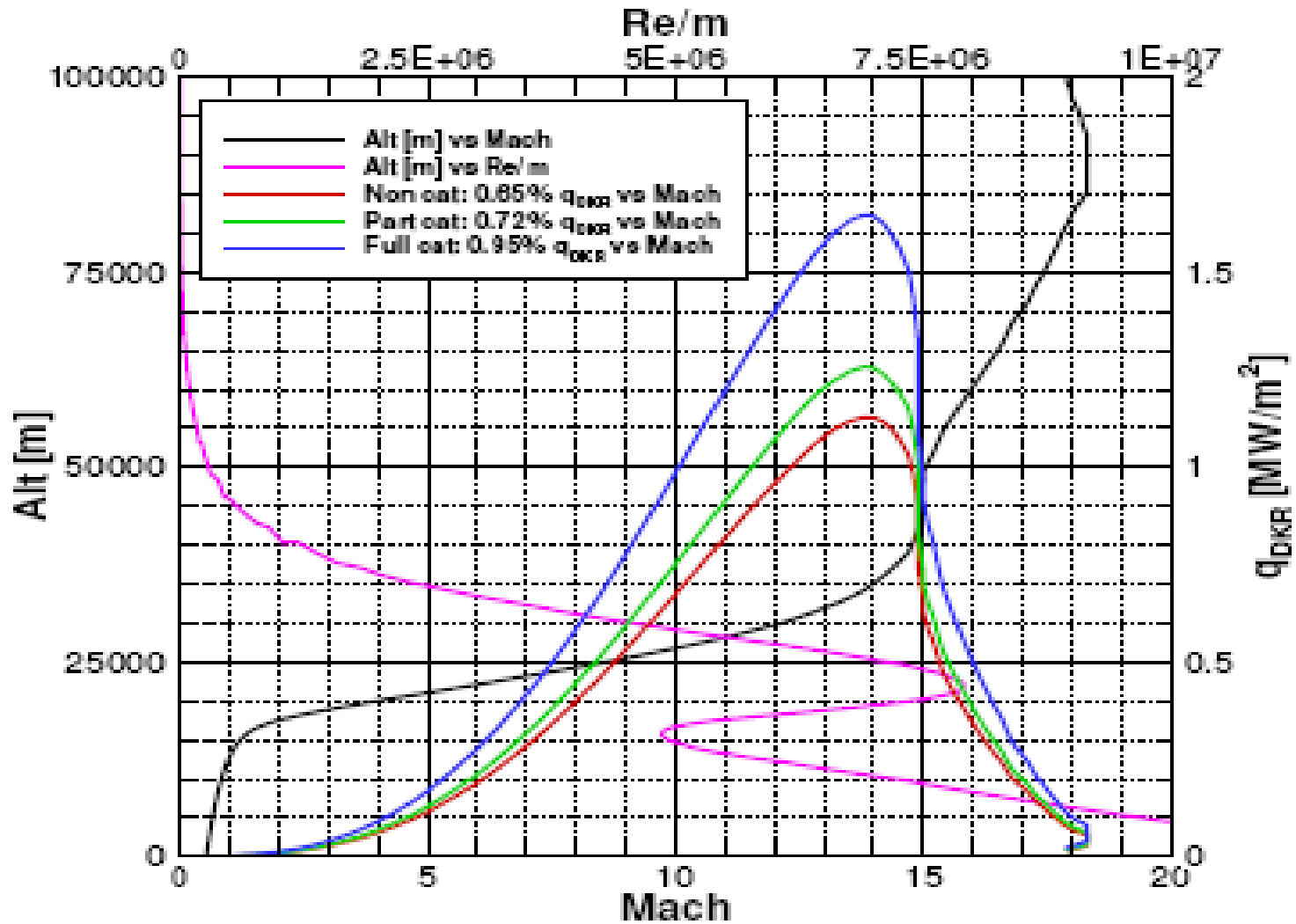
Pi=30 bars -  $\alpha=10^\circ$



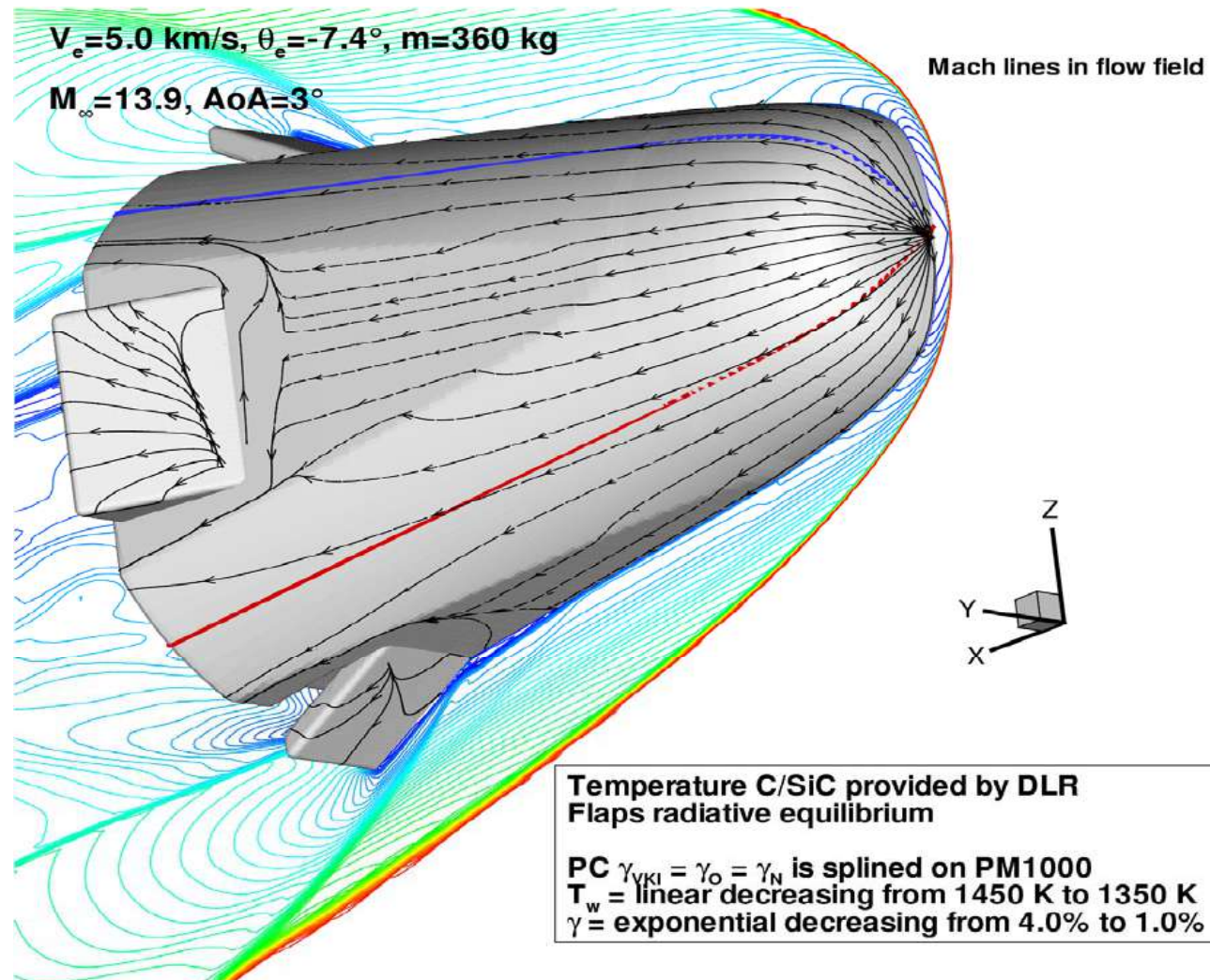
## Temperature jump at nose C-SiC/PM1000 junction



## Nominal 5 km/sec trajectory



## Off nominal flow pattern

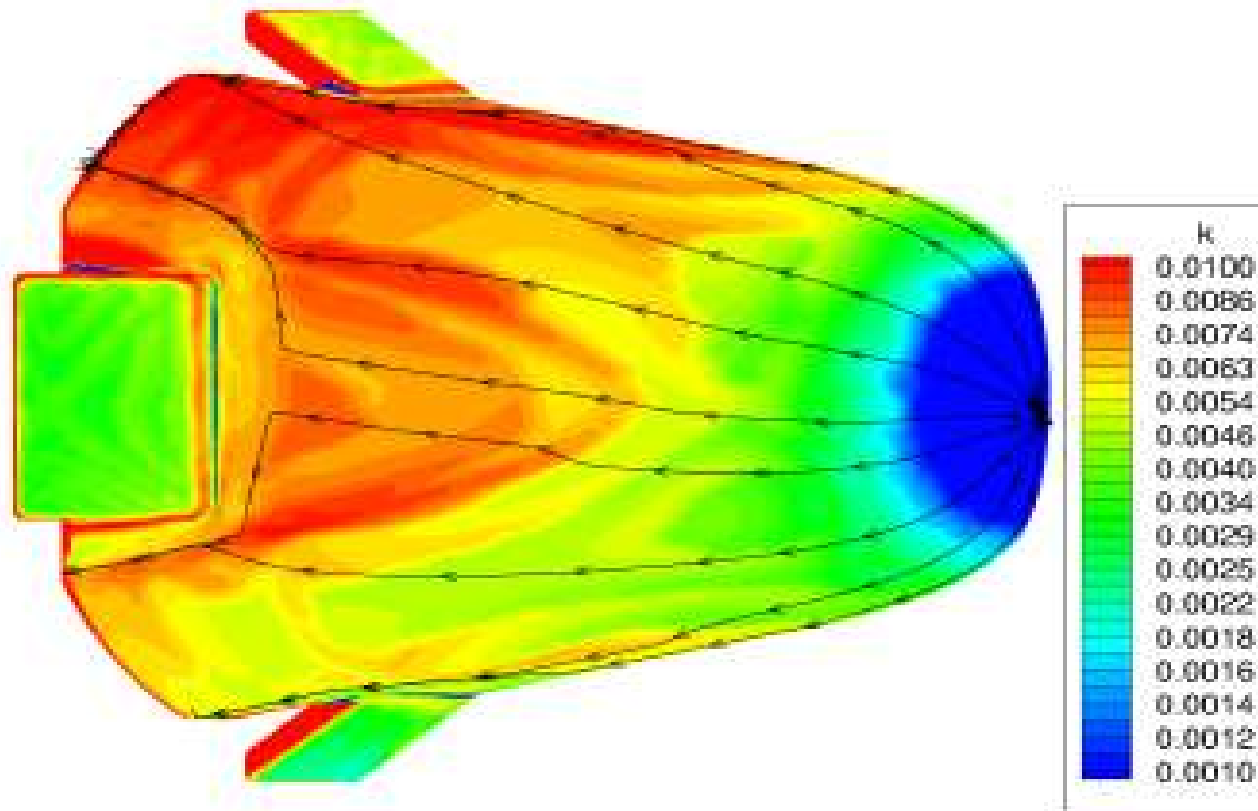
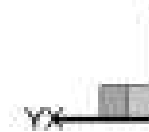


# Allowable Roughness Height

EXPERT 4.4.b at 50 km altitude

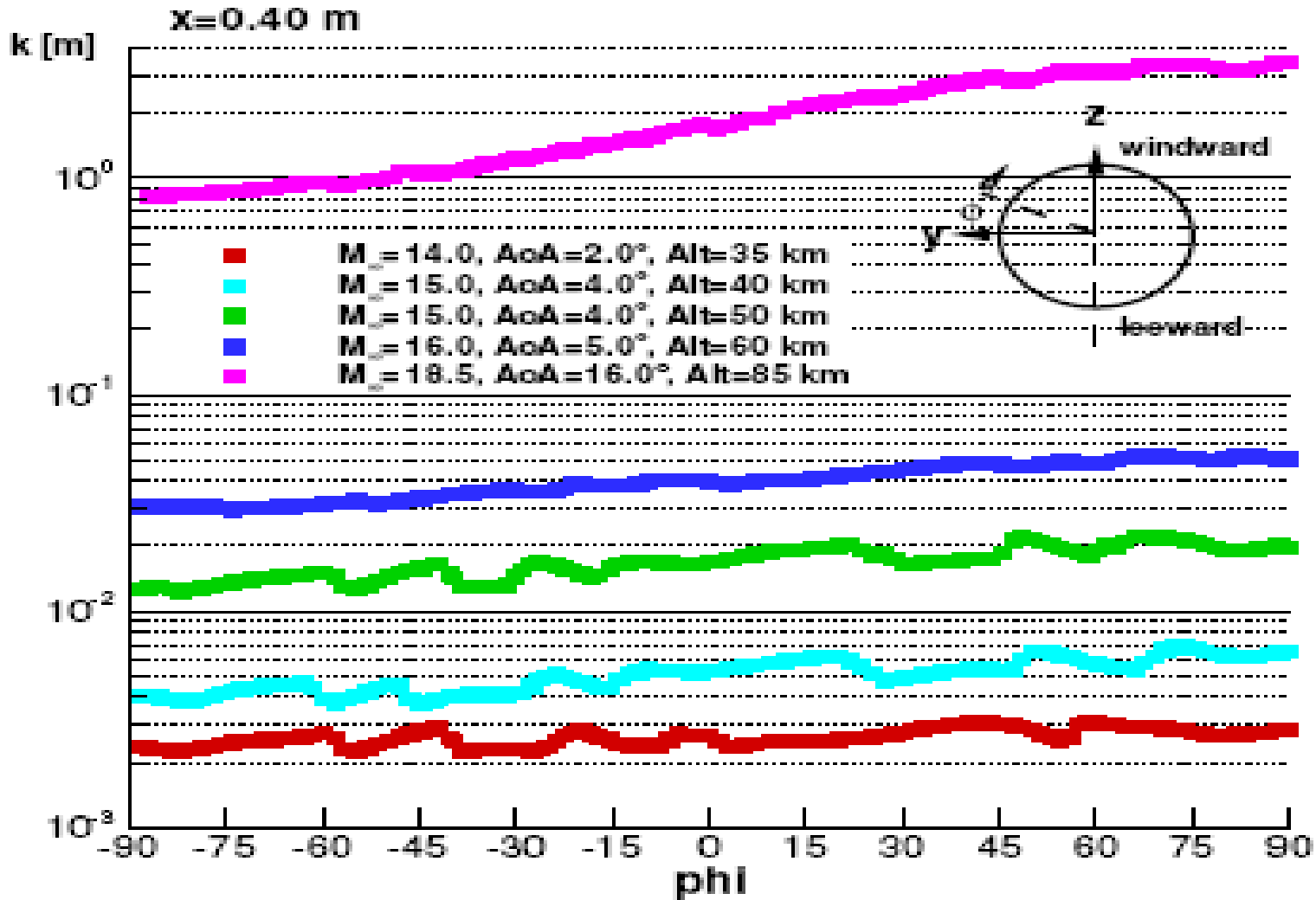
$M_\infty = 15.0$ ,  $AoA = 4.0^\circ$

Roughness induced height:  $k$  [m]



# Allowable step at nose junction

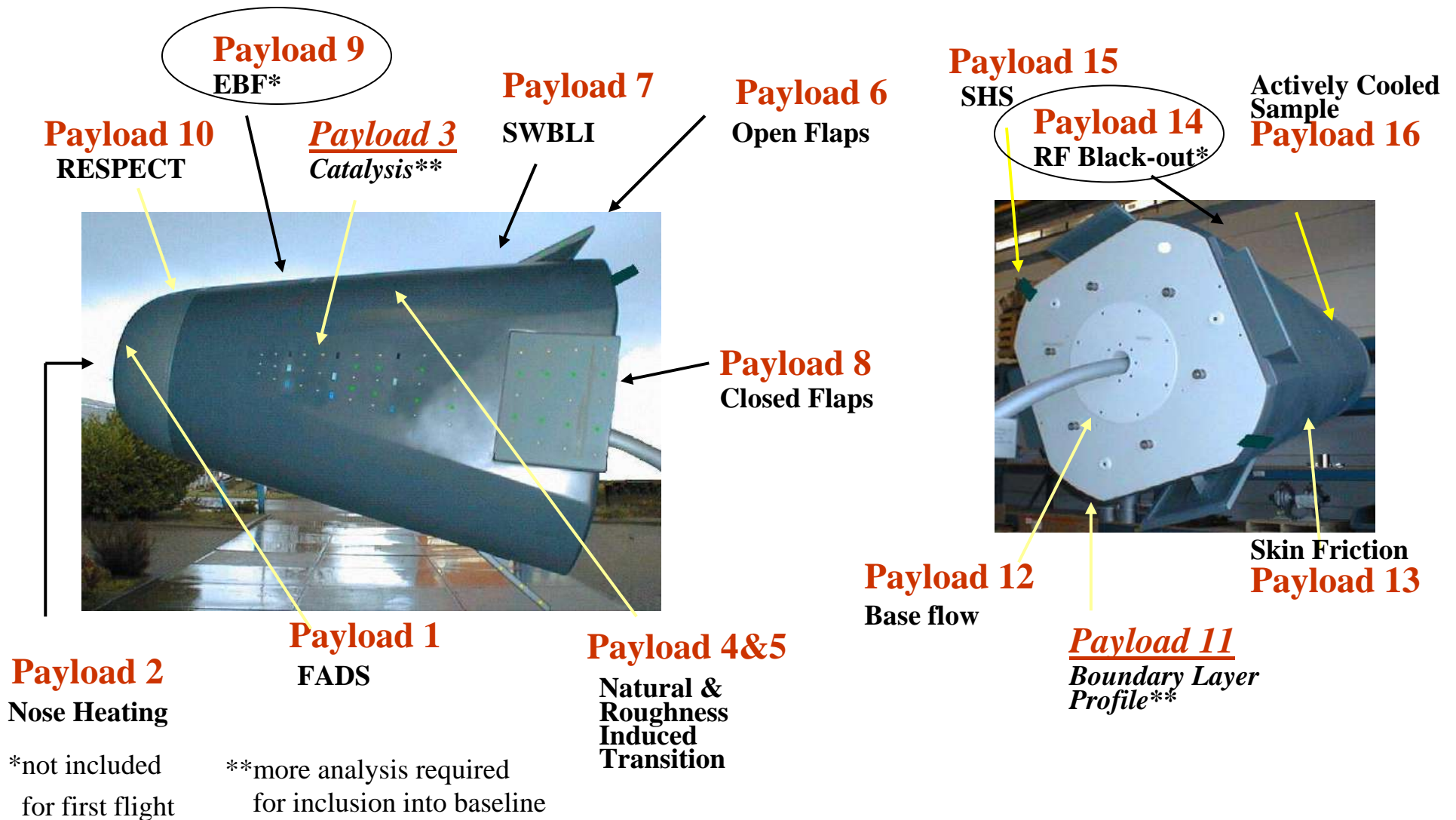
Roughness induce transition height



## Course Roadmap

- **Flight Experimentation Logic**
- **Motivation for in flight research**
- **EXPERT requirements**
- **Vehicle design and **Flight instrumentation****
- **Conclusions**

# EXPERT Payload Overview

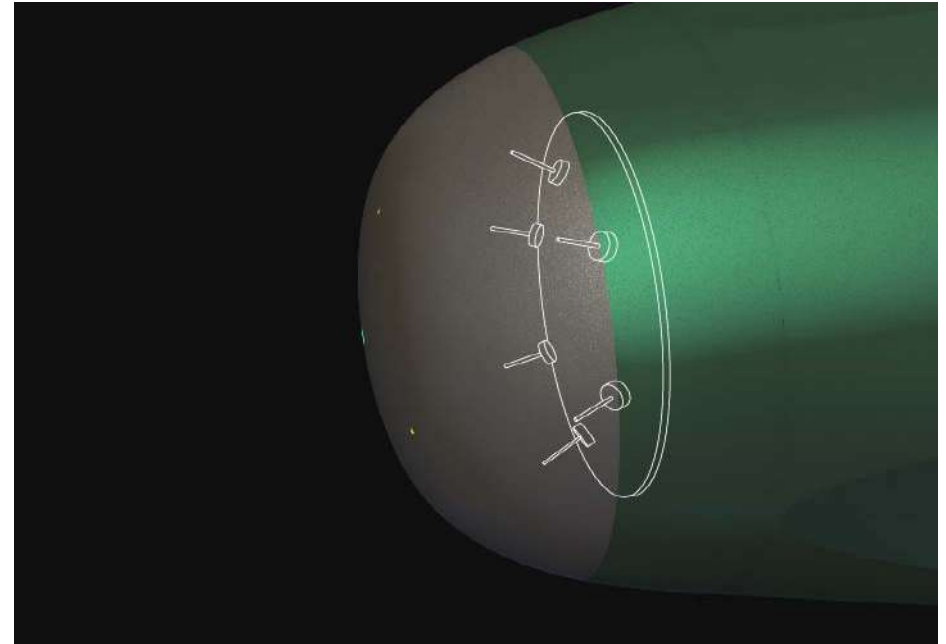
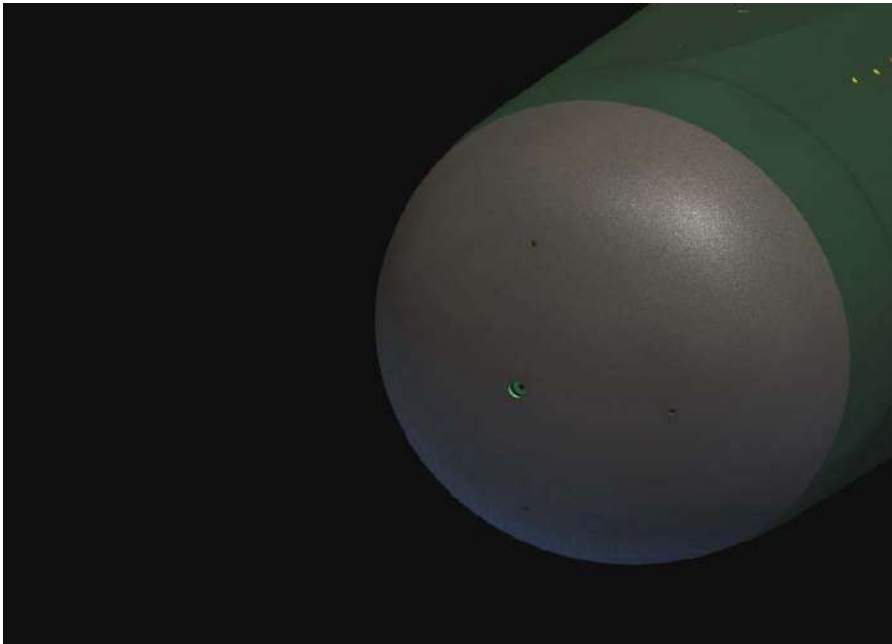


## **EXPERT Payload**

### **THE SCIENTIFIC PAYLOAD CONSISTS OF:**

- 1. ADS ( DLR, HTG)**
- 2. NOSE HEATING, PYREX (DLR, RS)**
- 3. CATALYSIS (EADS, VKI, UNI ROME, IRS)**
- 4. ROUGHNESS INDUCED TRANSITION (CIRA, VKI, ONERA)**
- 5. OPEN FLAP ATD (DLR, MAN) AND SWBLI (CIRA)**
- 6. CLOSED FLAP , IR ( HTS, SNECMA, ONERA, EPFL, CFS, RUAG, CMR)**
- 7. EBF (ONERA)**
- 8. RESPECT,EMISSION SPEC.( IRS, CENTROSPAZIO/ALTA)**
- 9. PITOT STATIC AND LANGMUIR (VKI)**
- 10. BASE FLOW (CENTROSPAZIO, UNI ROME, SENER)**
- 11. SLIP FLOW (HTG)**
- 12. BLACKOUT (UNI TORINO)**
- 13. UHTC PASSENGER (CIRA, CSM, UNI NAPLES)**
- 14. COOLED TPS PASSENGER (TUD)**

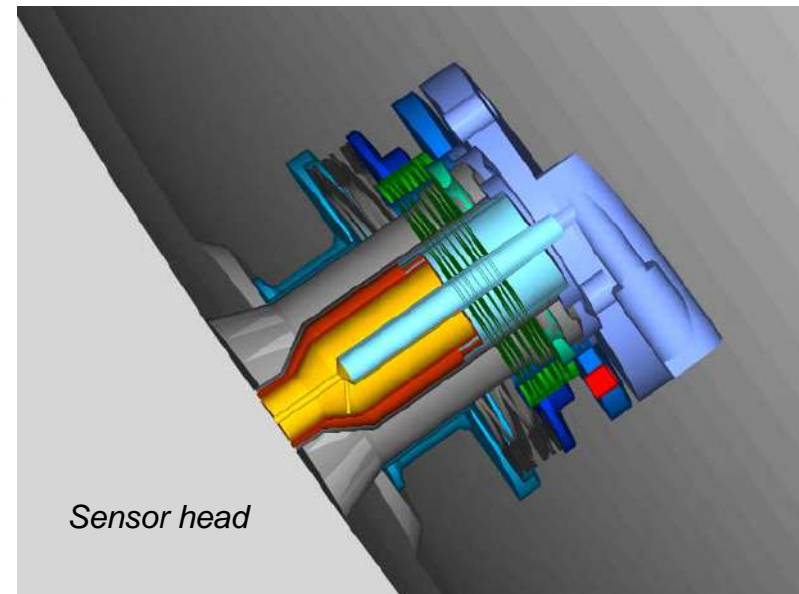
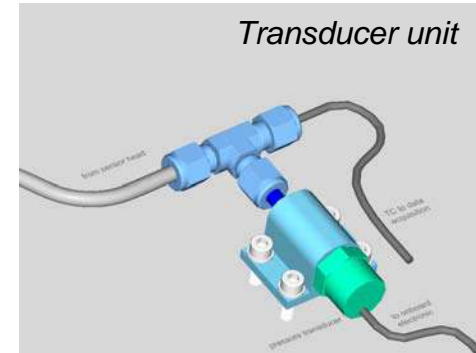
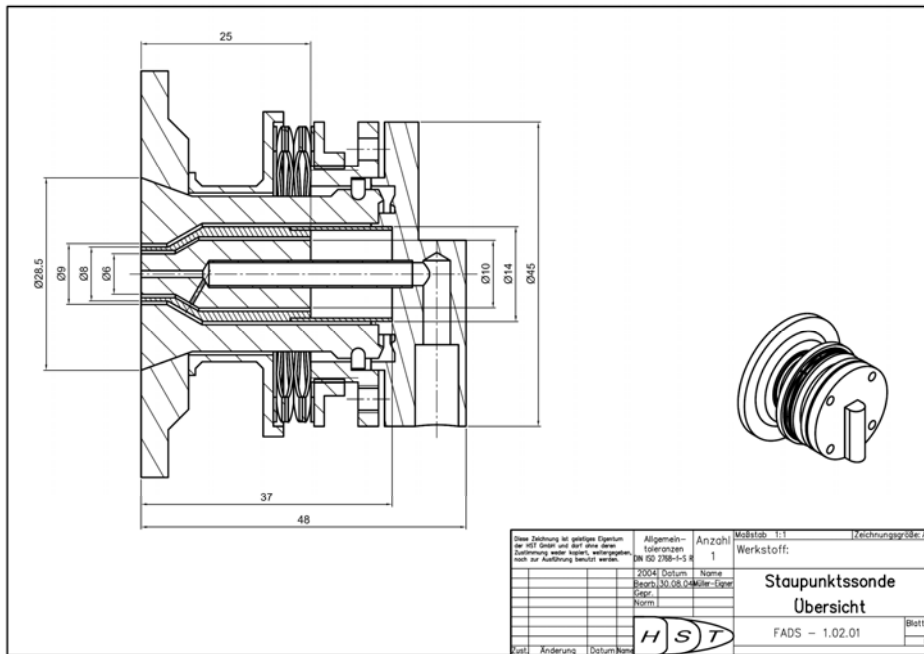
## ADS and pyrex



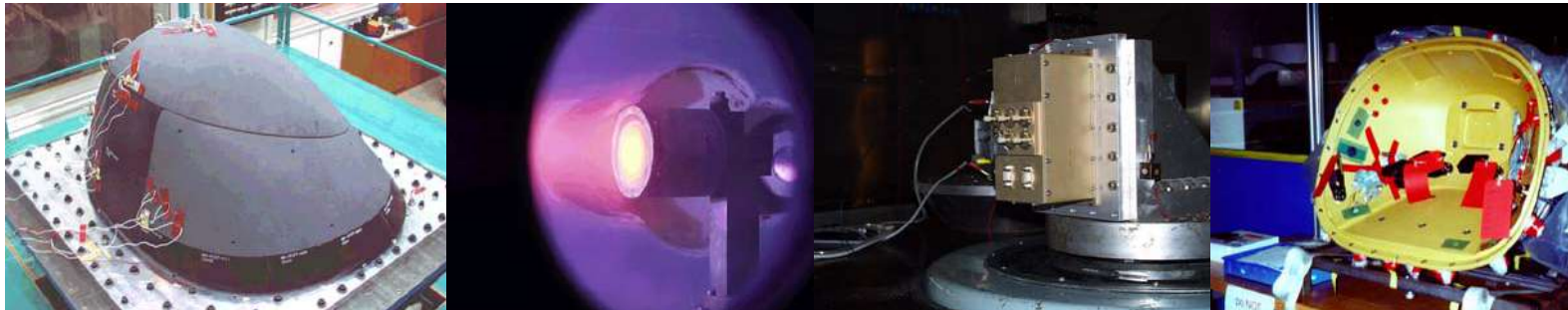


# RAFLEX FADS

## CAD Models



# PYREX Nose heating Experiment



TETRA nose assembly and thermo-mechanical nose tests

**PYREX-EM**

- ⇒ Several lives proved
- ⇒ Measurement successful

- ⇒ **EM** Qualification (IRS PWK1)
- ⇒ Approval Test of **FM** (IRS PWK1)

(Simulation of X-38 heat flux profile)

**FM SU** Mechanical Test

- All axes tested. Sequence:
1. resonance search, 0.5 g
  2. vibration test
  3. resonance search, 0.5 g
  4. Calibration check (calibrated lamp)

**FM Integration, JSC**  
(X-38 nose structure)

- ⇒ Functional Test after Transport
- ⇒ Test and Calibration check

**In addition:** Test of Software and Hardware Interface to X38 Front End Electronics using PYREX EM SU, Black Body Calibration and SU Integration Test

**Heritage of PYREX to EXPRESS, MIRKA and X-38**

## PYREX Nose heating Experiment

Scientific Goals:

Temperature and heat flux measurement  
inside nose cone

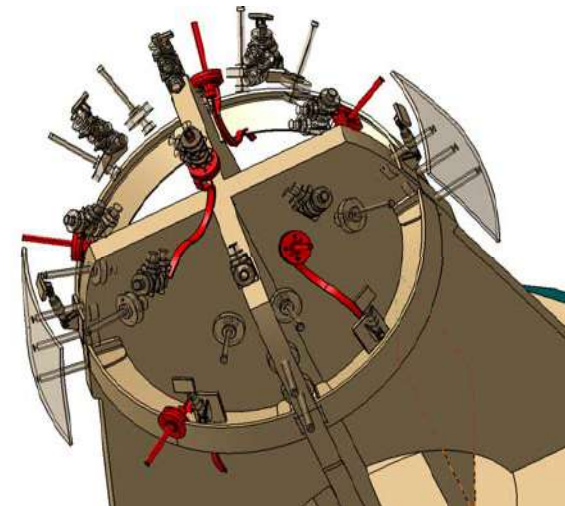
⇒ Validation of numerical models /  
codes

System consists of:

- ↓ 6 PYREX Sensors (SH 1-6)
- ↓ Mounting on cold structure
- ↓ Fiber Optics and holding Brackets
- ↓ Sensor Unit (SU)
- ↓ Interface to OBDH

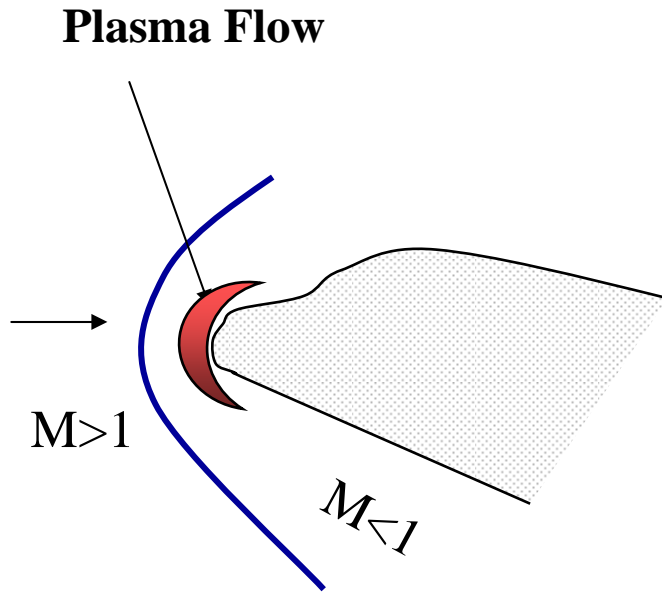
PYREX:

Measurement in six locations



Prelim Positions of PYREX

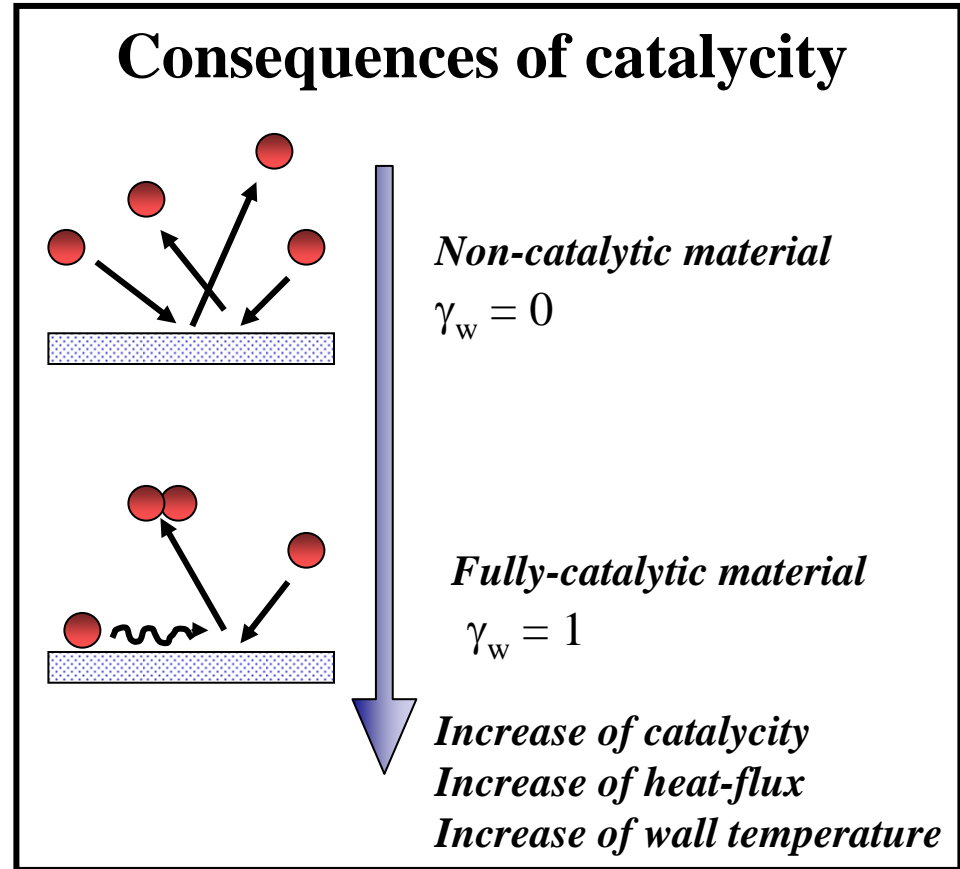
# Catalysis



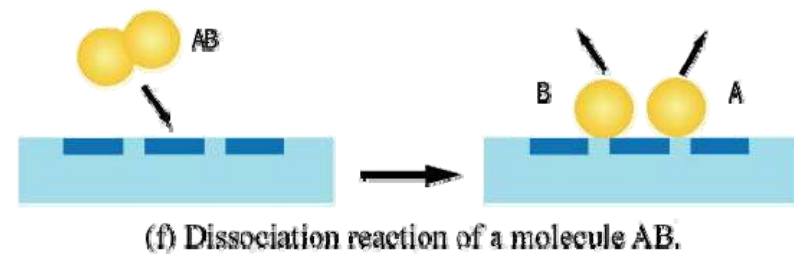
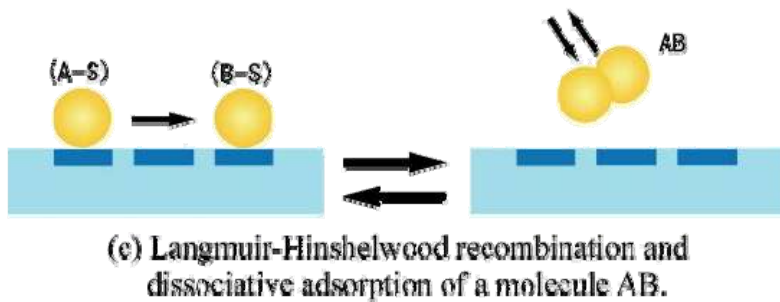
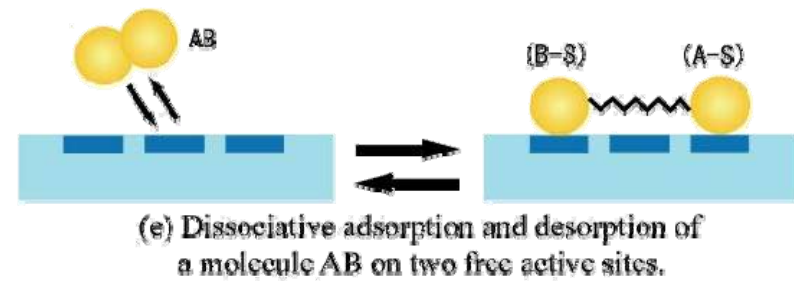
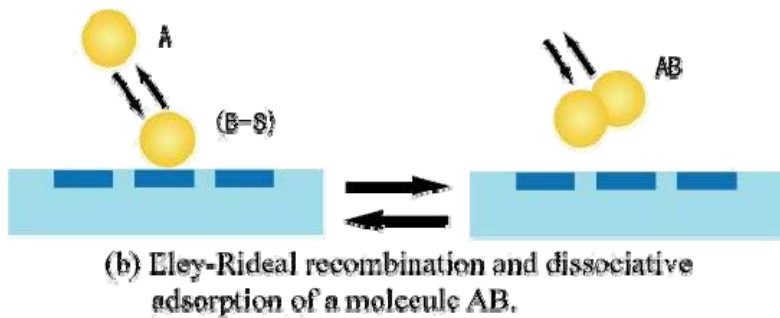
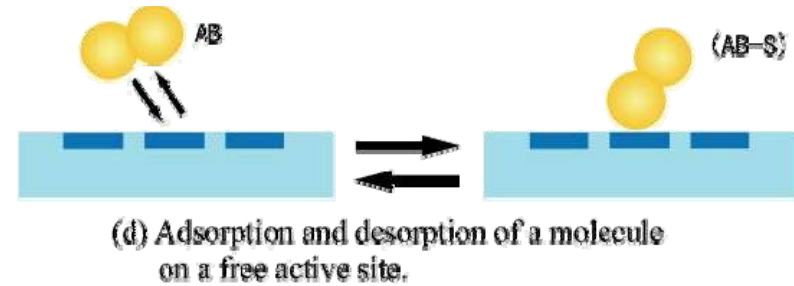
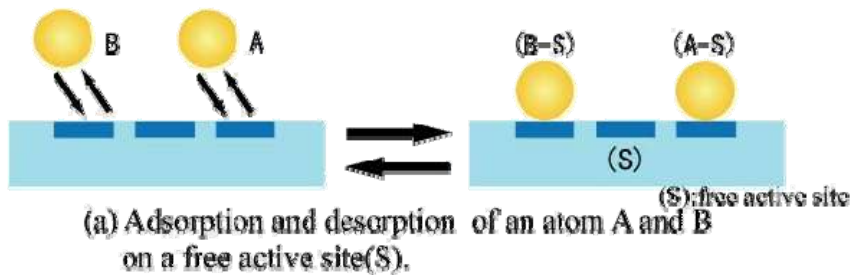
**Deceleration**



**Kinetic energy** ↔ **Thermal energy**

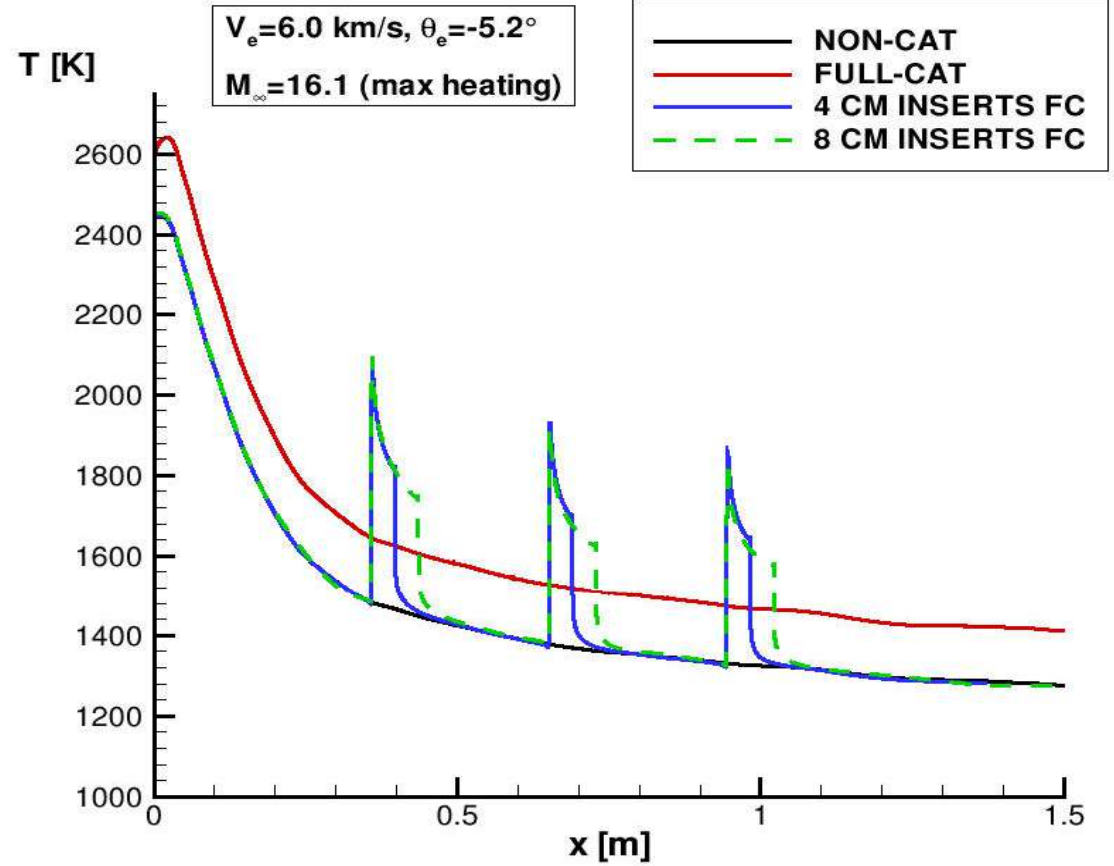
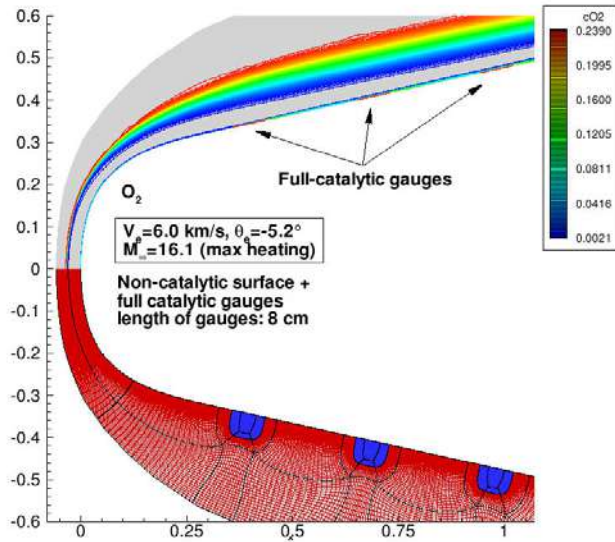
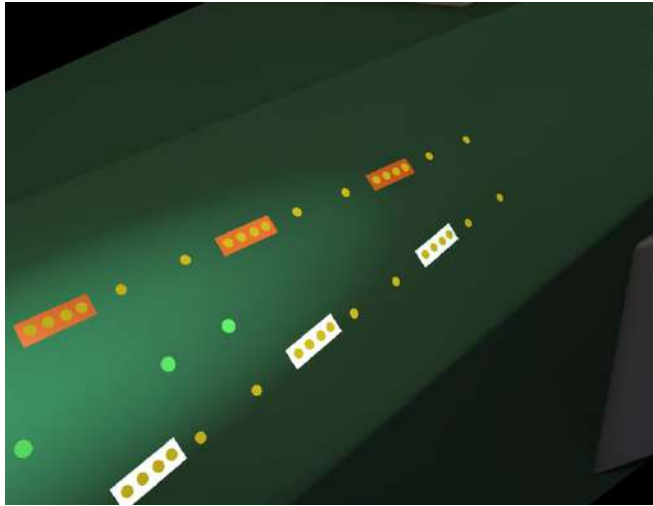


## Catalysis Modelling

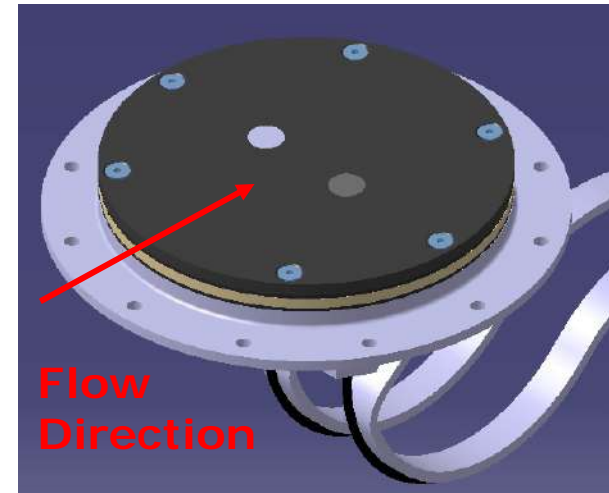
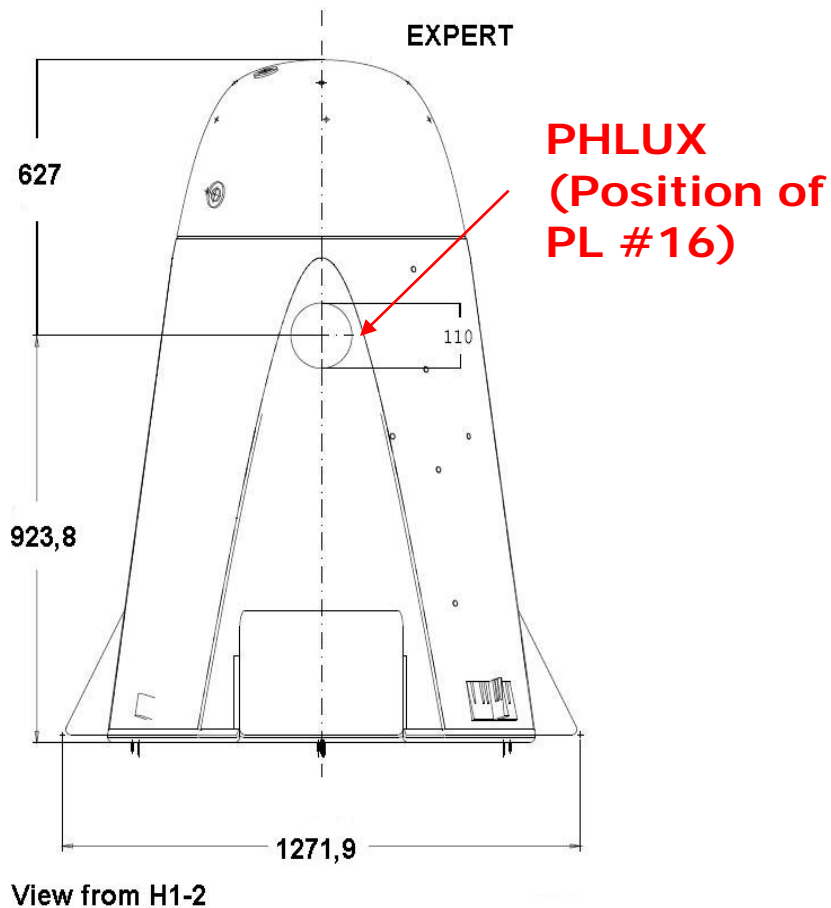


Chemical Processes in Heterogeneous Catalysis on surface

# Catalysis



# Catalysis with PHLUX and imbedded Thermocouples



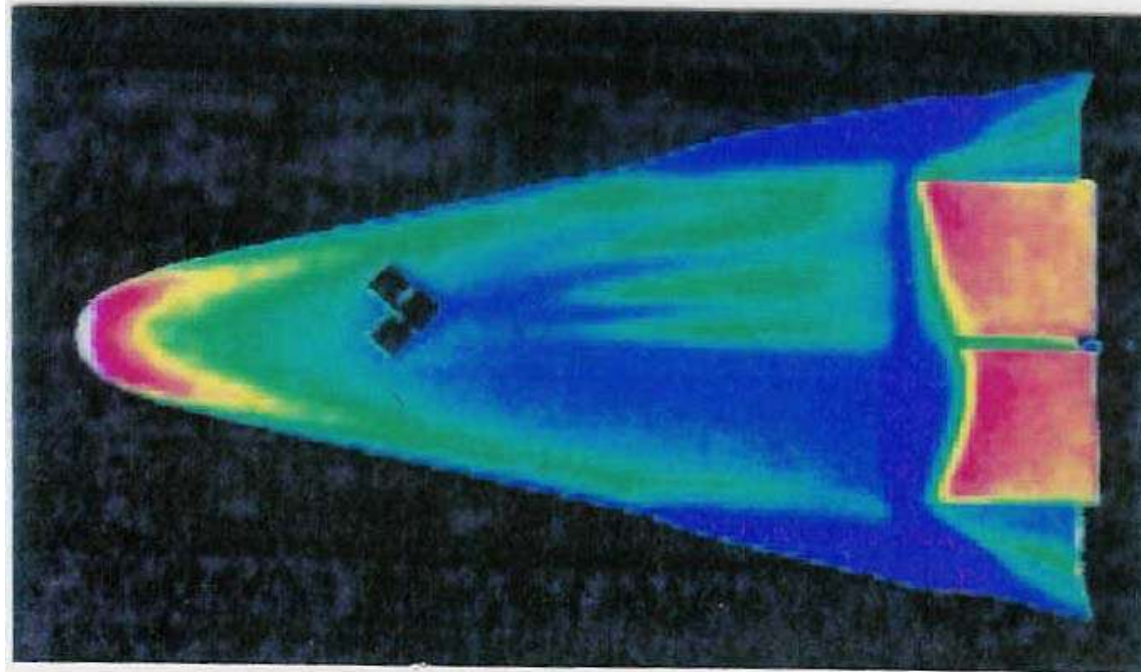
PHLUX Sensor pair





**Roughness  
induced  
Transition**

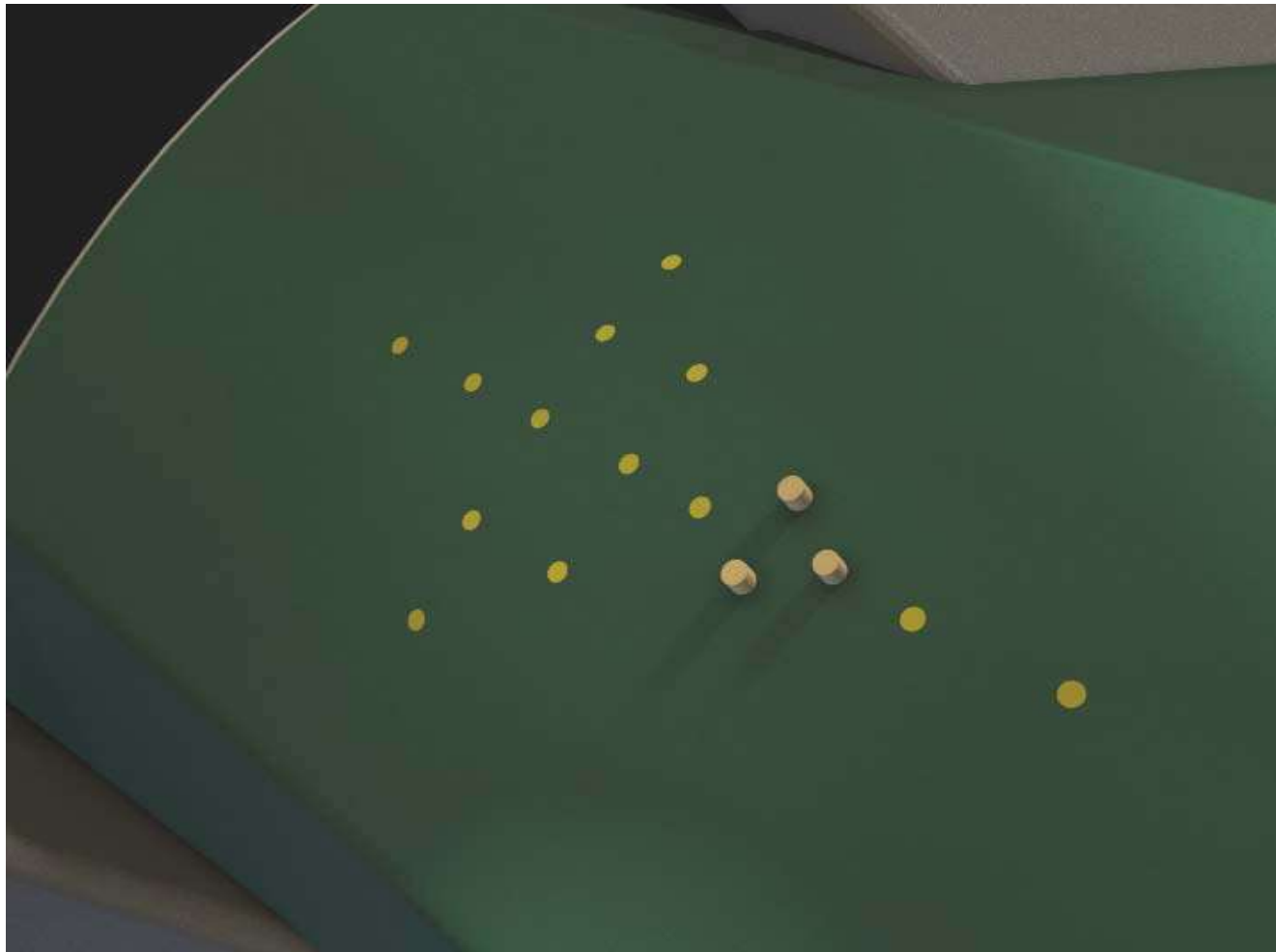
## X38 Induced Transition



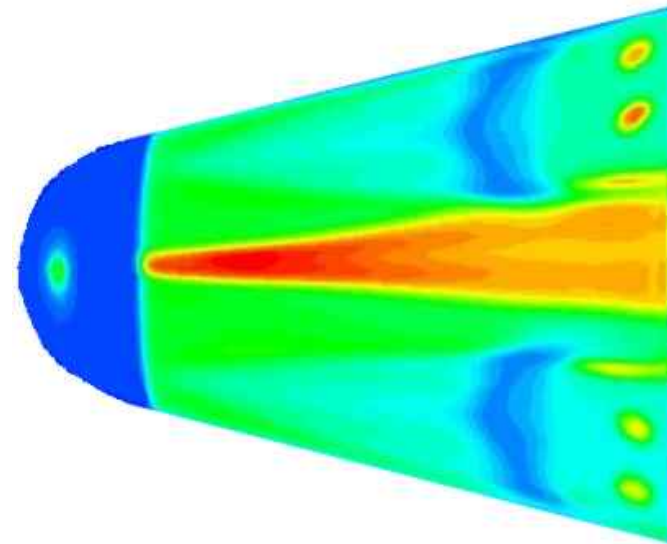
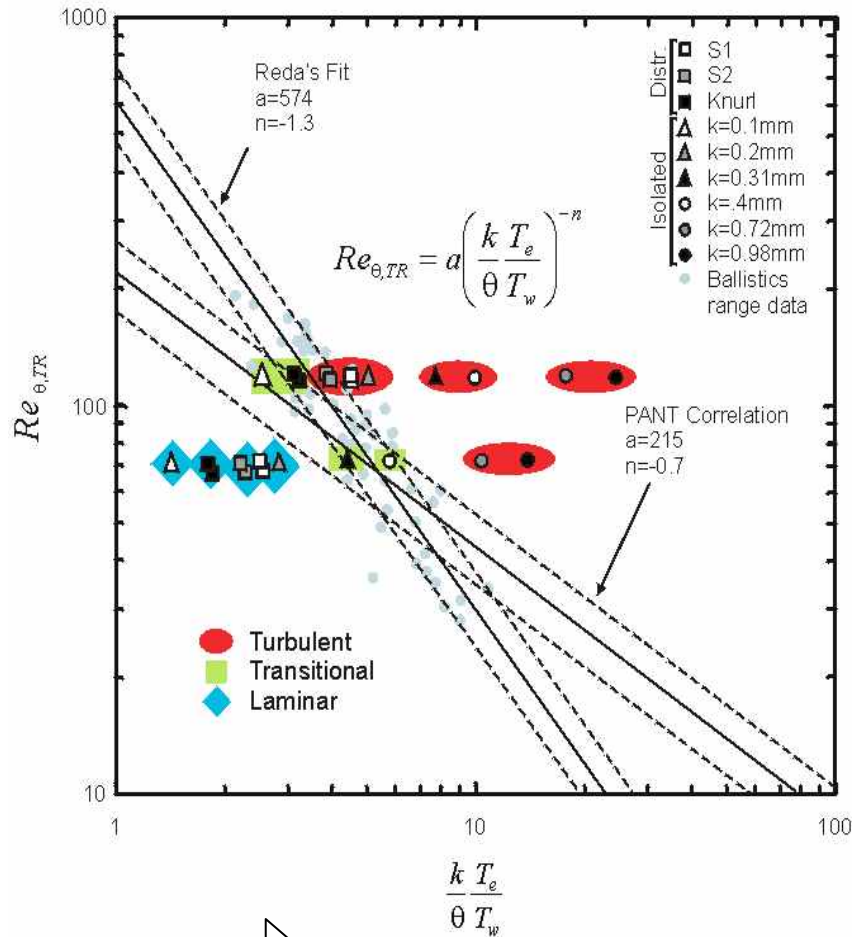
Run # 131  
Windward View  
Model # 3  
BF @ 25°  
 $\alpha = 40^\circ$   
 $Re_{\infty}/ft = 2.2 \times 10^6$   
0.0050-in. Trip  
@  $x/L = 0.3$   
Width = 0.4-in.  
Orientation = 45°

Courtesy of NASA Langley (Mach 6)

## Roughness Induced Transition

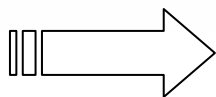


# Roughness induced Transition VKI-H3



$Re=2.5 \times 10^7/m$

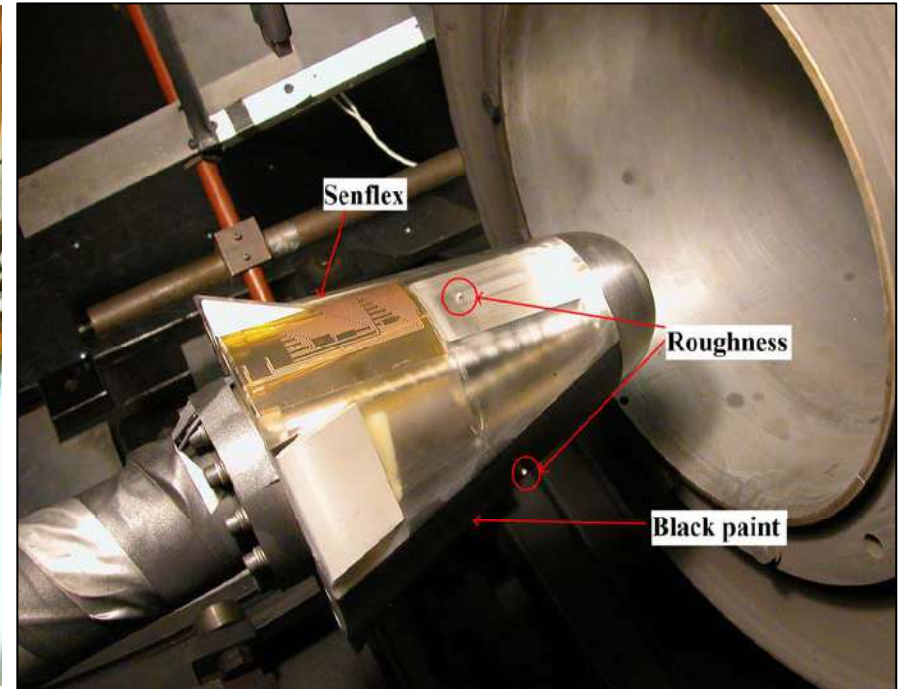
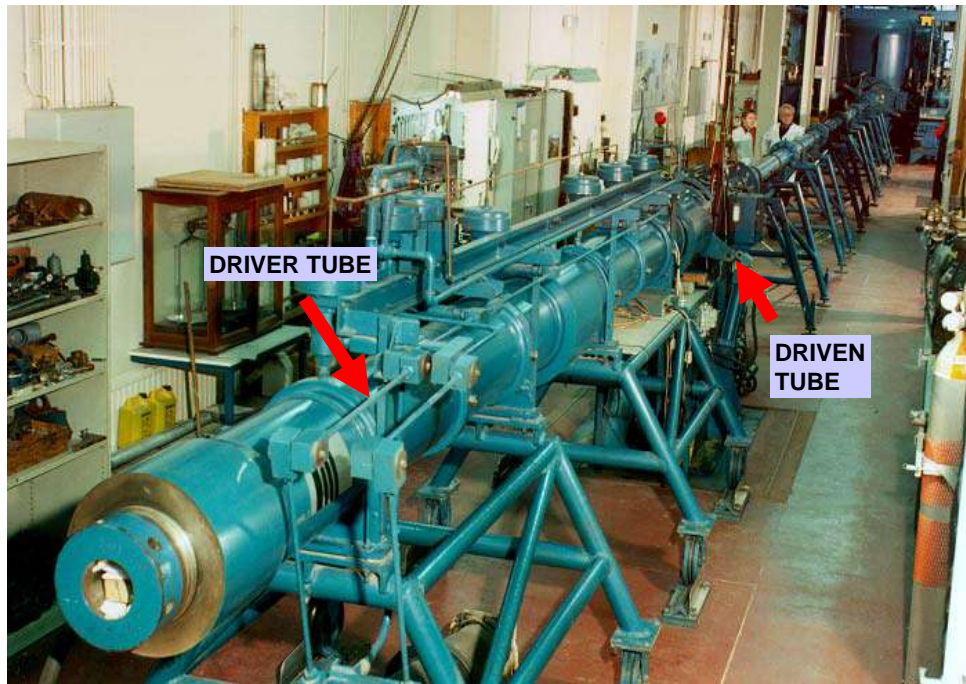
$k=0.200mm$



**Continuation in Longshot**

# Roughness Induced Transition

## Tests in VKI-Longshot



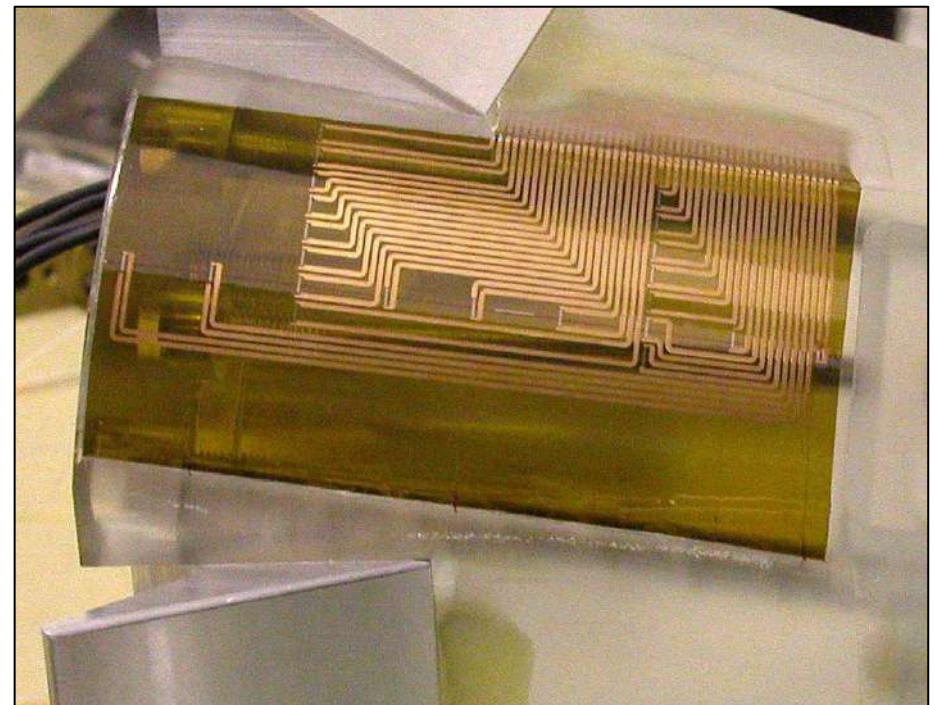
- FLIR SC3000 Thermocam for one corner, thin film sensors
- High speed Schlieren movies to verify boundary layer condition

# Roughness Induced Transition

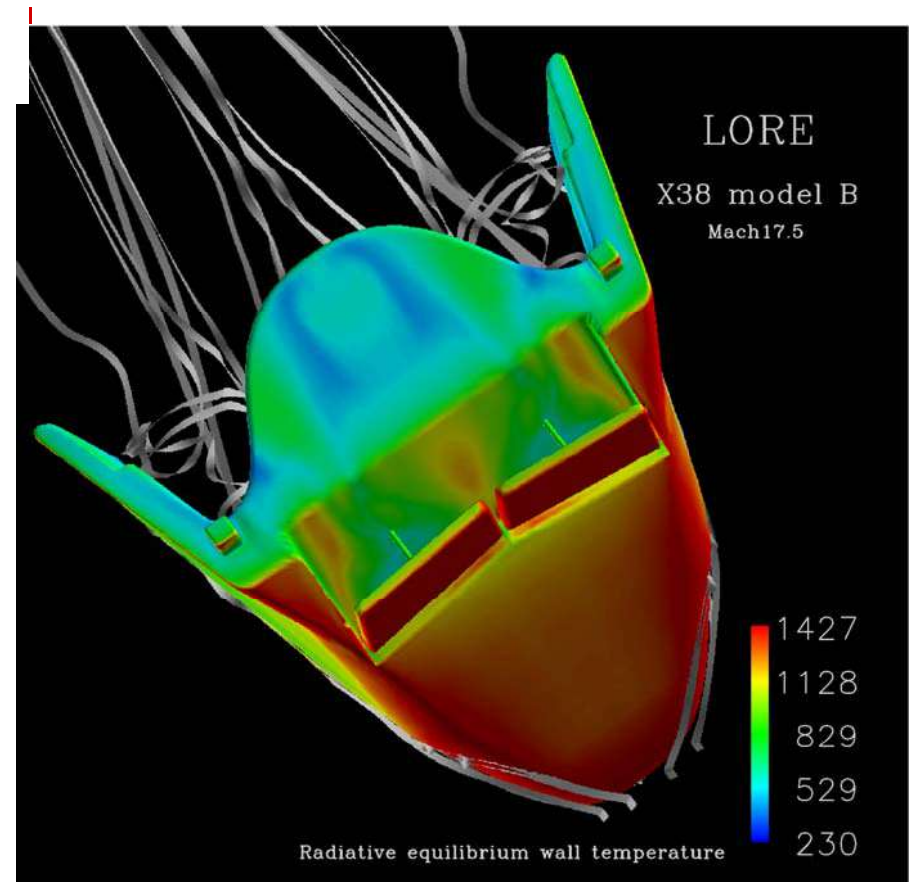
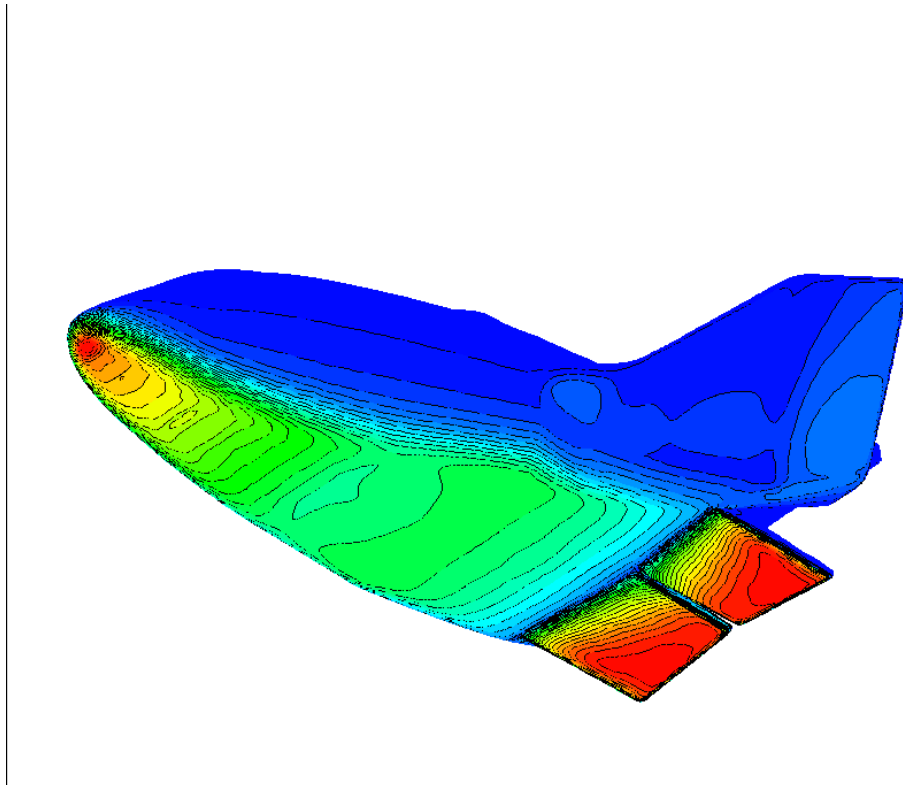
## Tests in VKI-Longshot

Senflex TF Sensors:

Flexible imprinted circuit sheet made in array, representative of flight layout Suitable for flight?



## X38 Flap Heating and Micro ATD

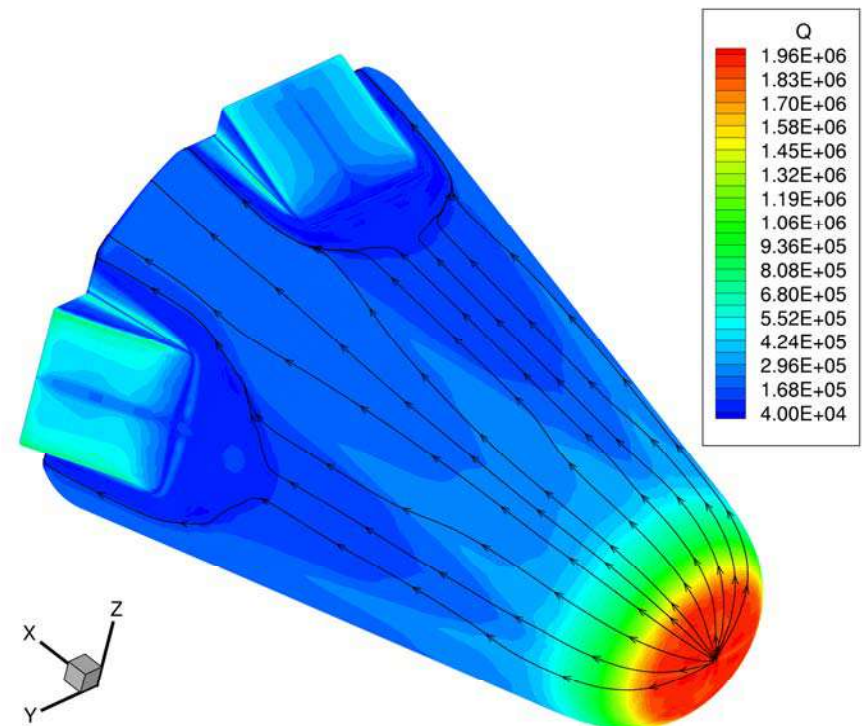
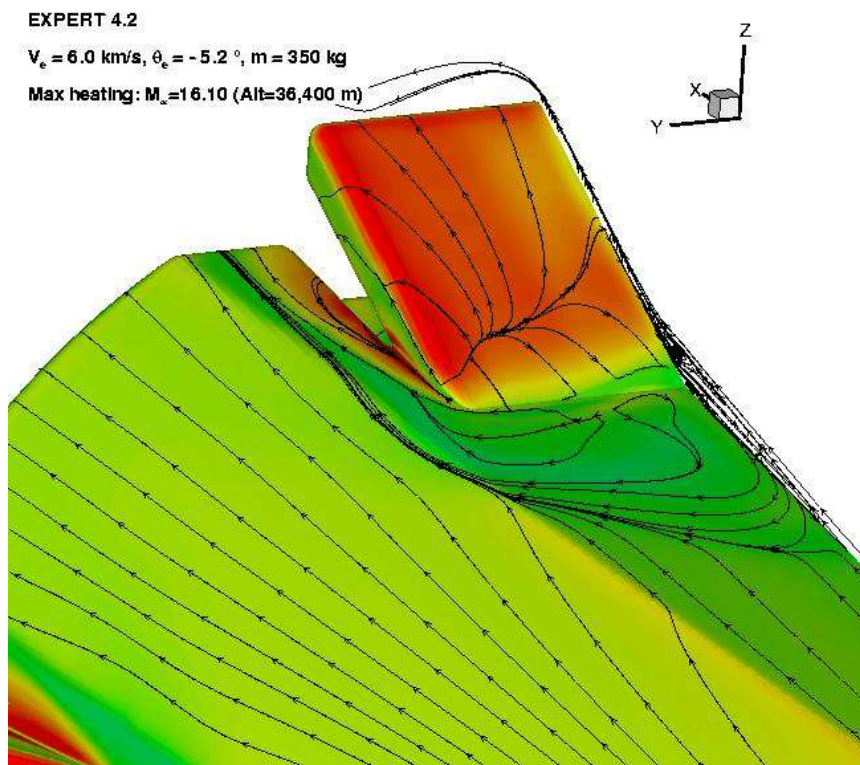




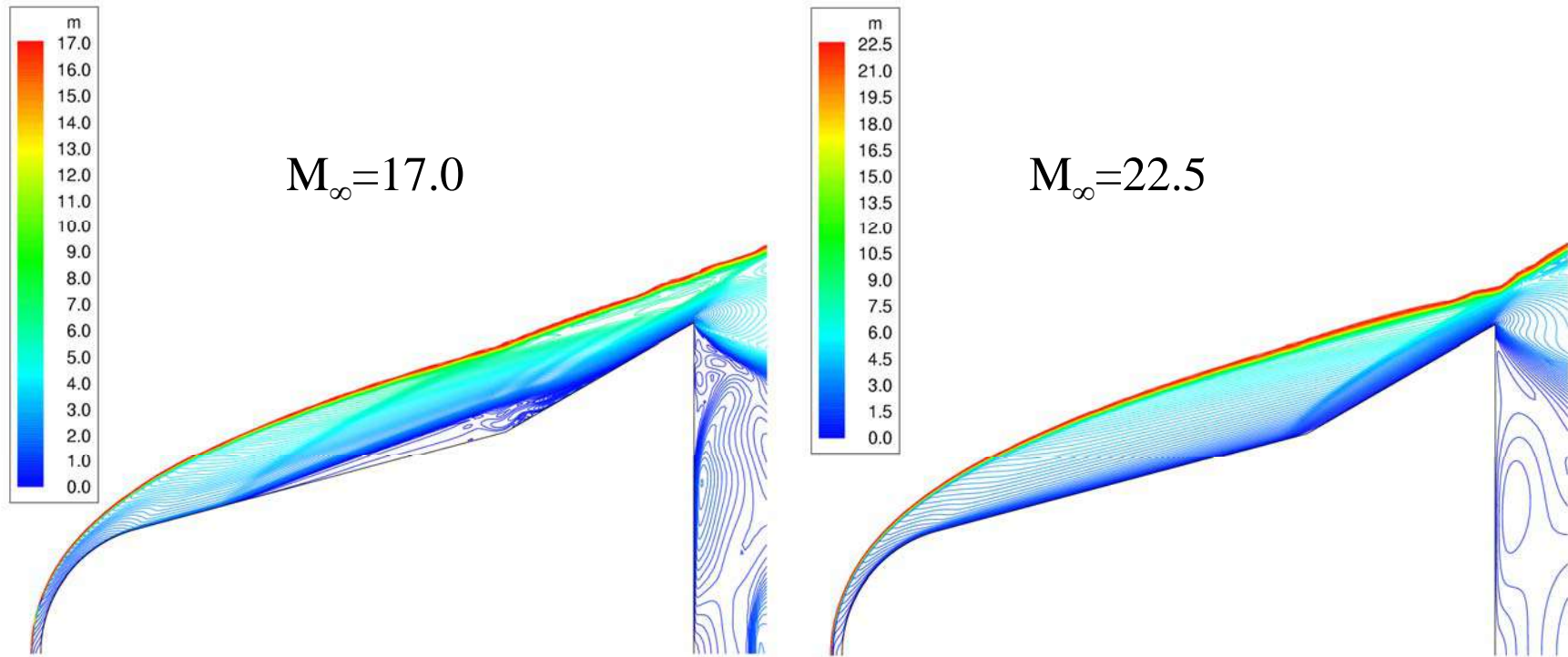
## **SWBLI – local Aerothermo- dynamics :**

- **Instrumented open flaps  
( pressure , temp., moments)**
- **Advanced methods ( Pyrex,  
IR camera)**

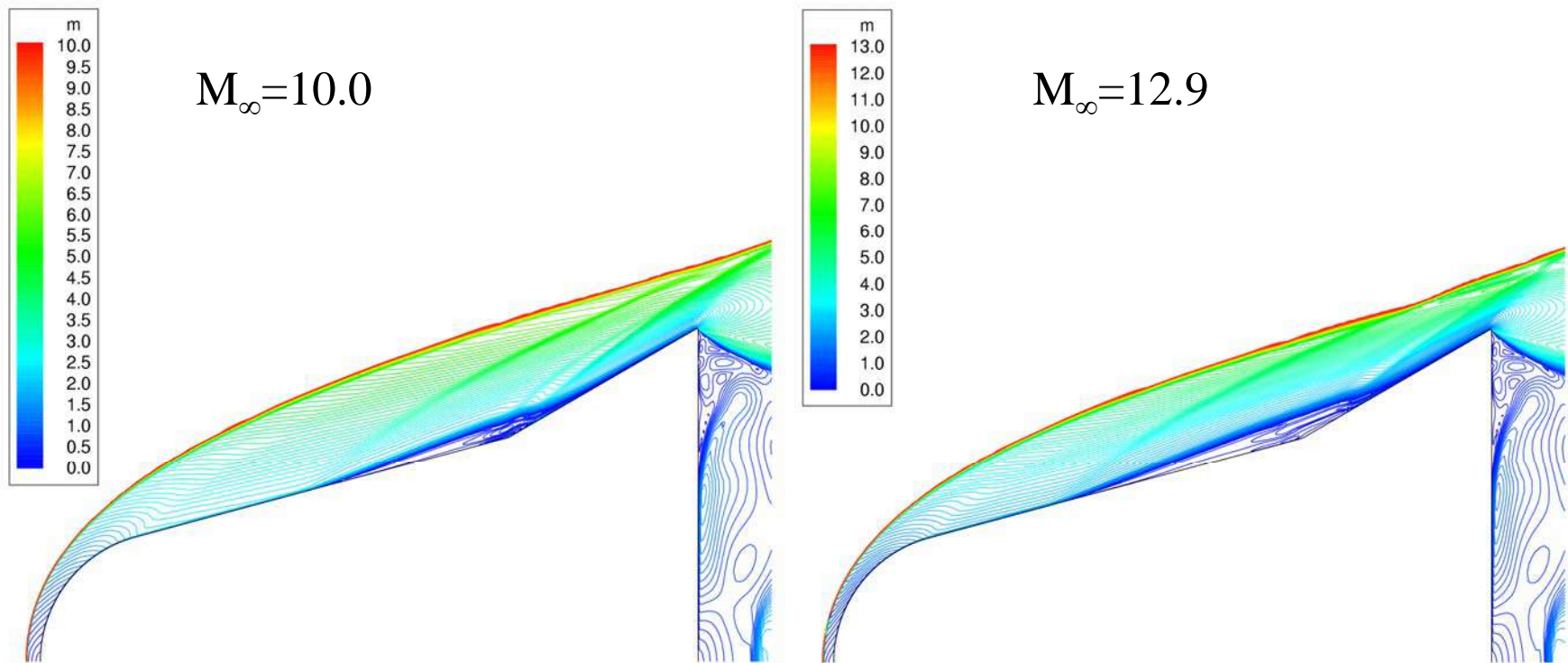
## Open Flap SWBLI

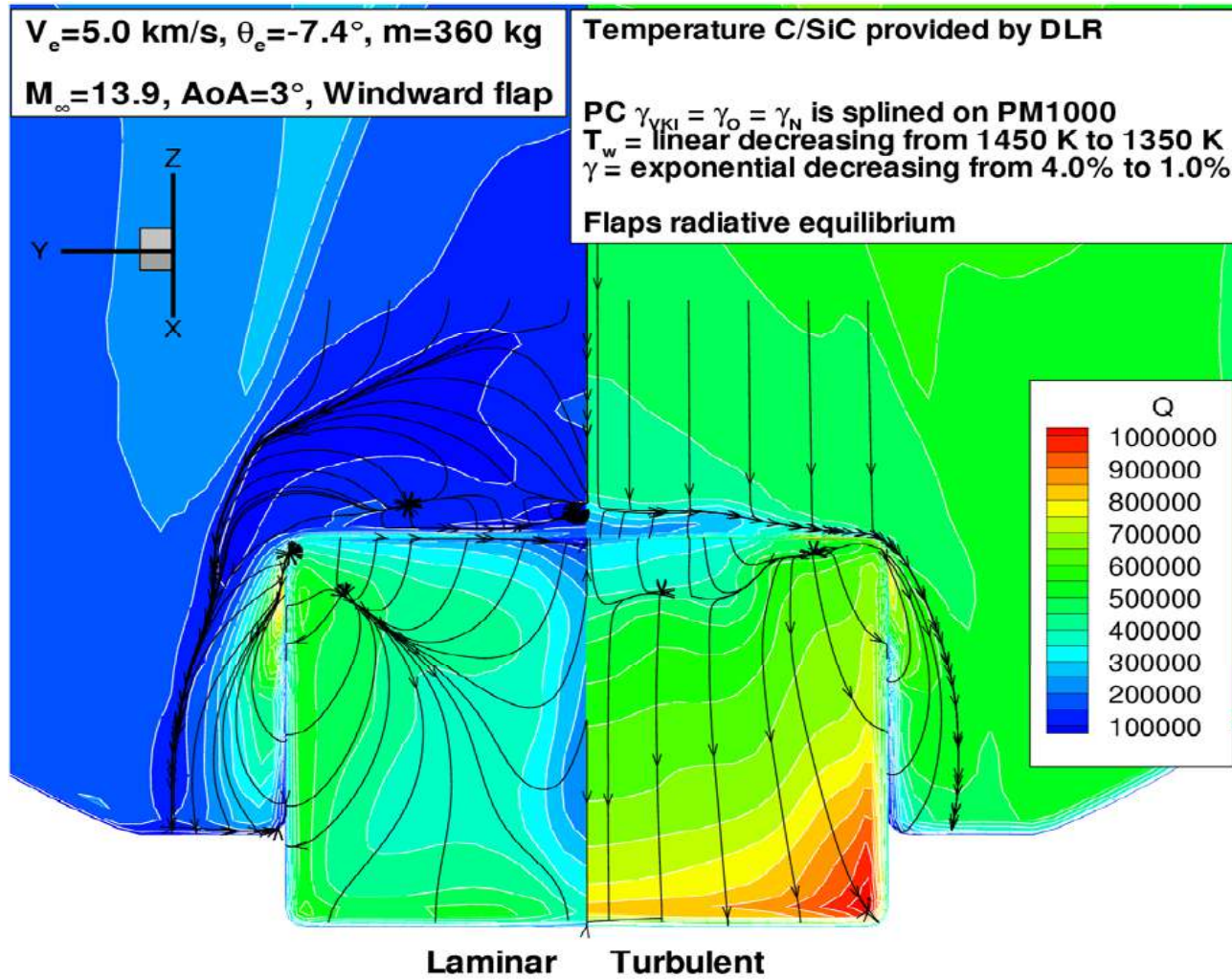


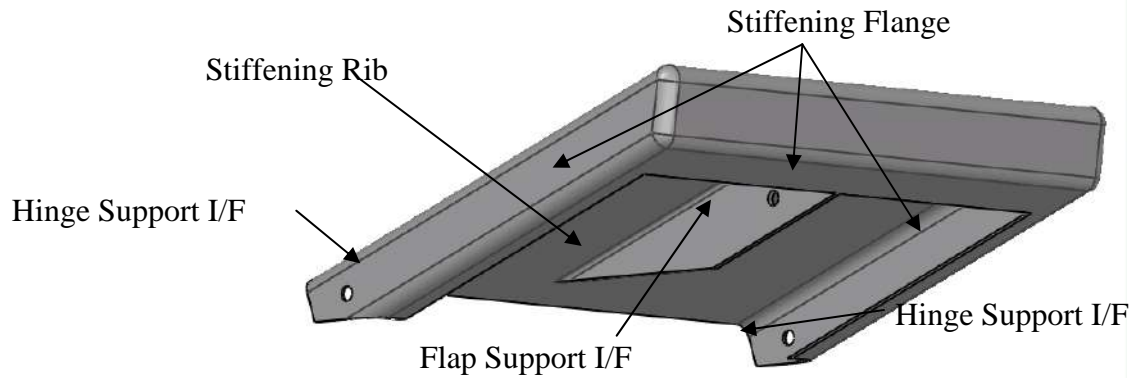
# Hypersonic NS-NE computations



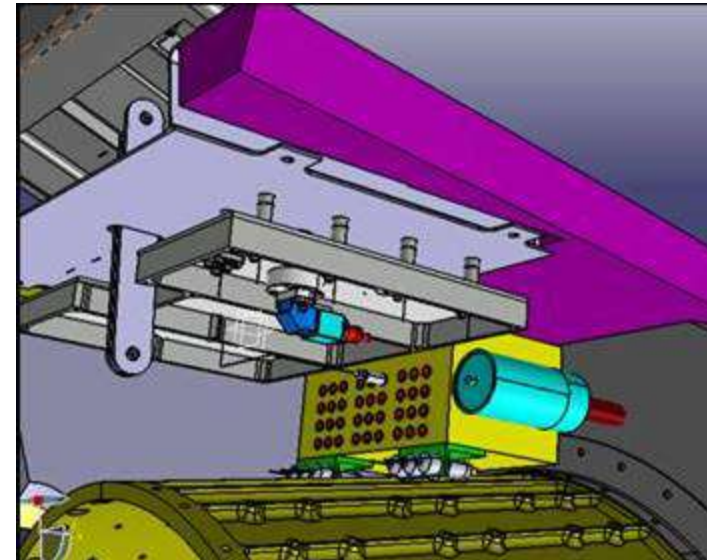
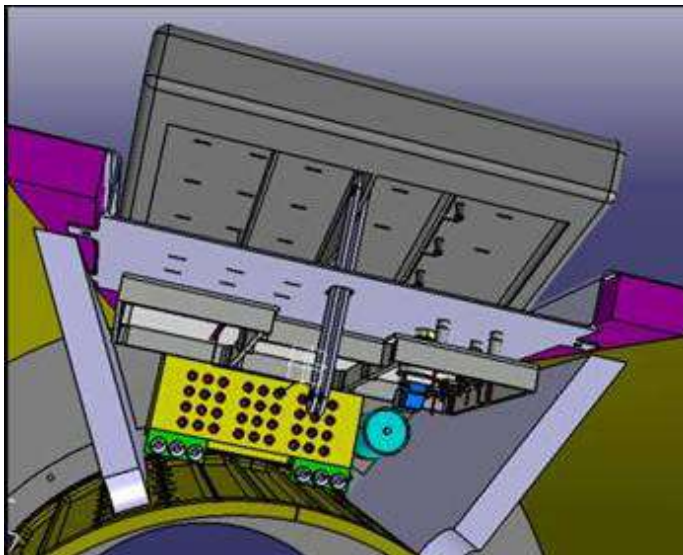
# Hypersonic NS-NE computations



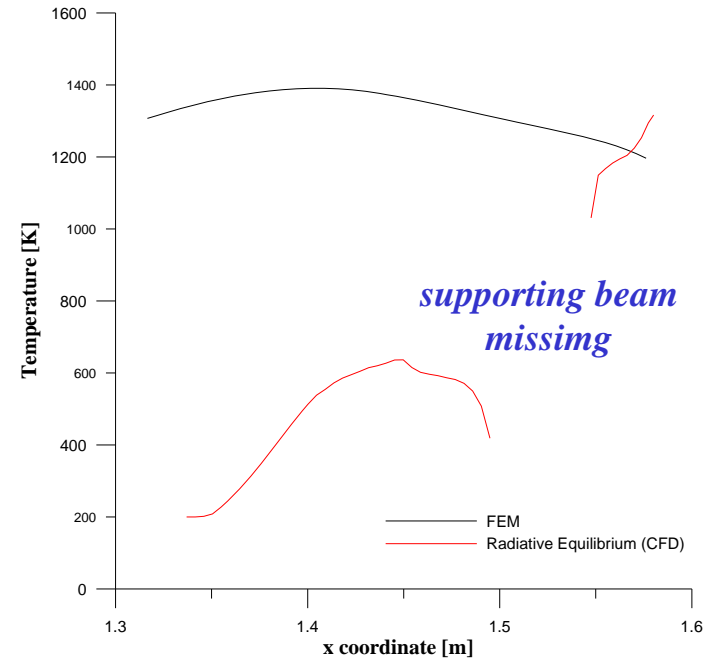
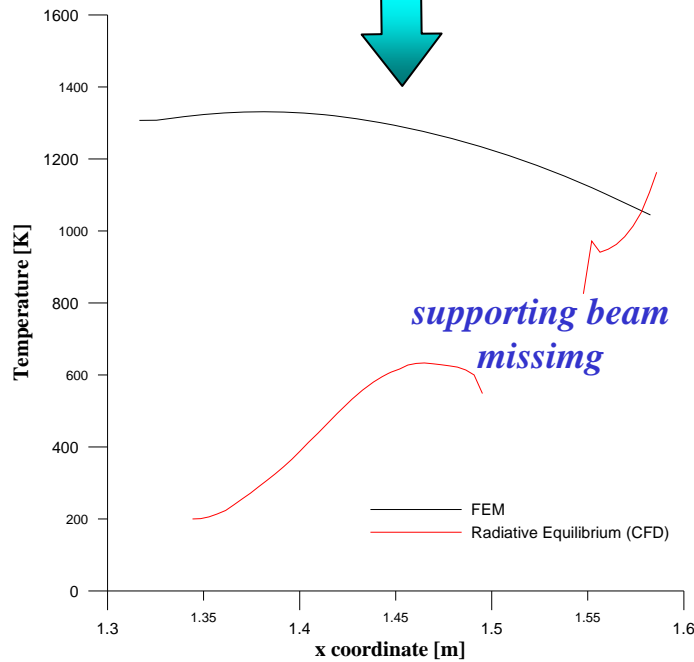
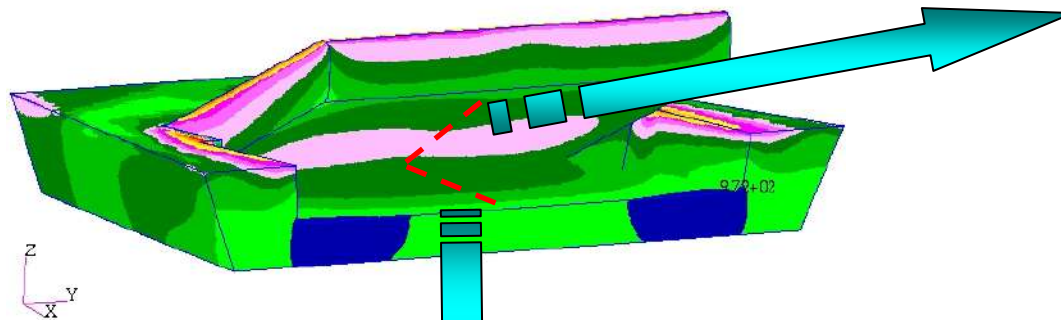




## Open Flap

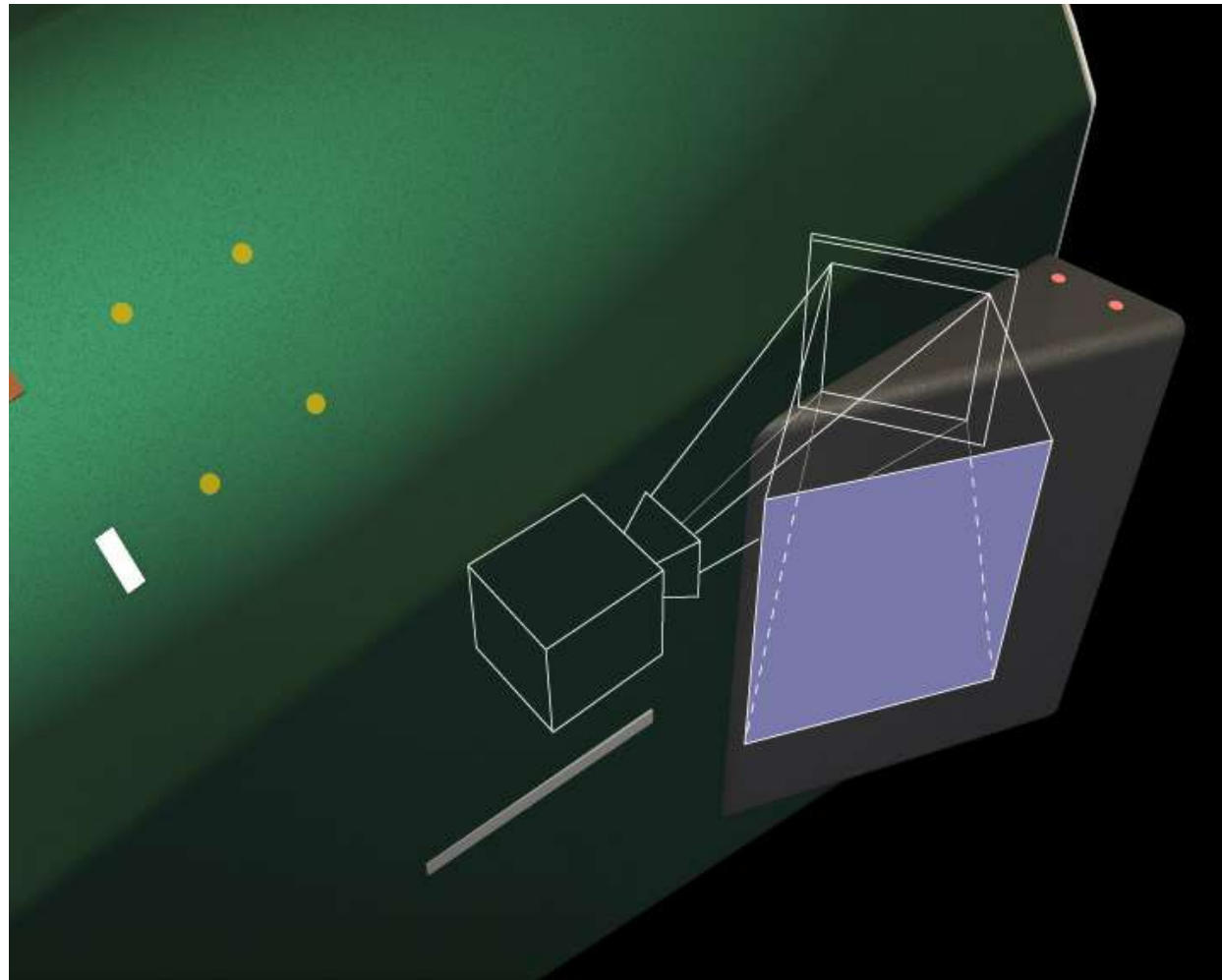


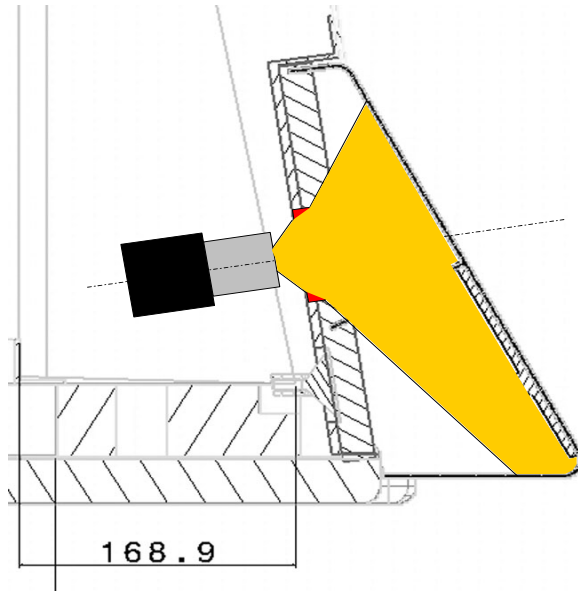
# Temperature in flap cavity bay



Because of *conduction and radiation* the backside temperature is much higher than the corresponding radiative equilibrium wall temperature.

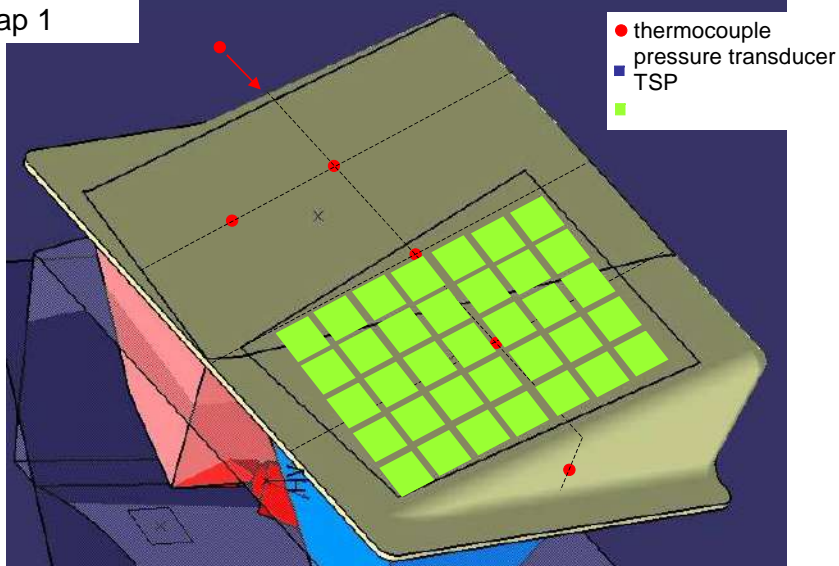
## IR Camera



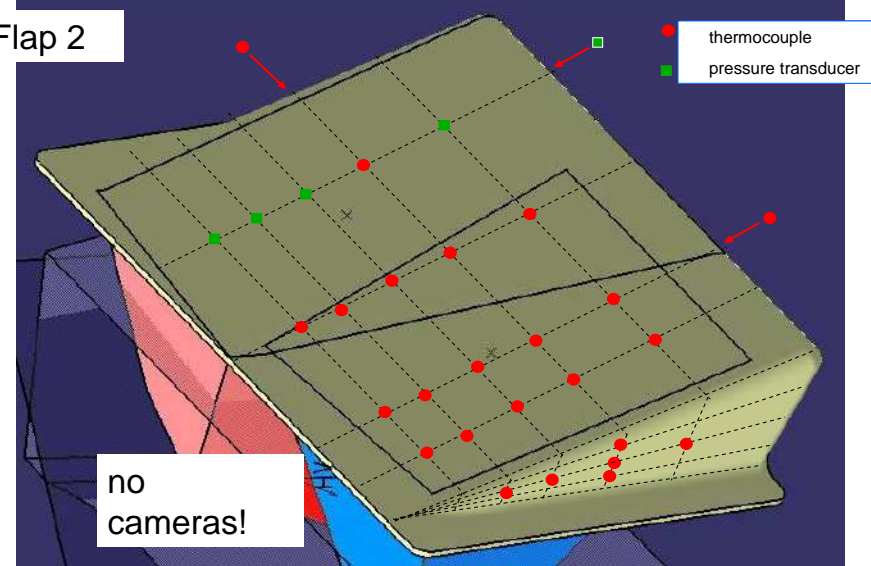


## IR Camera Flap

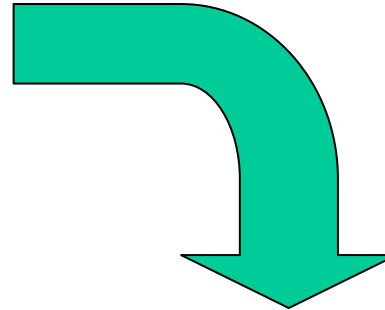
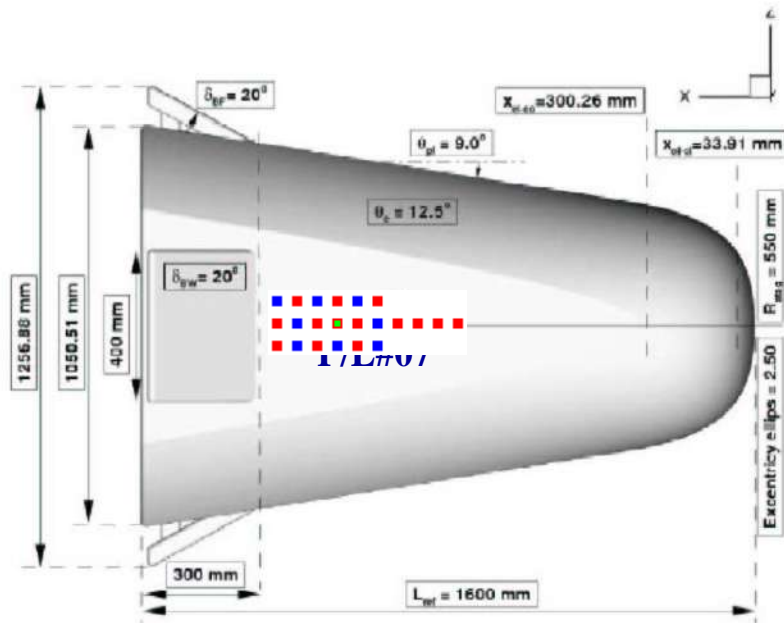
Flap 1



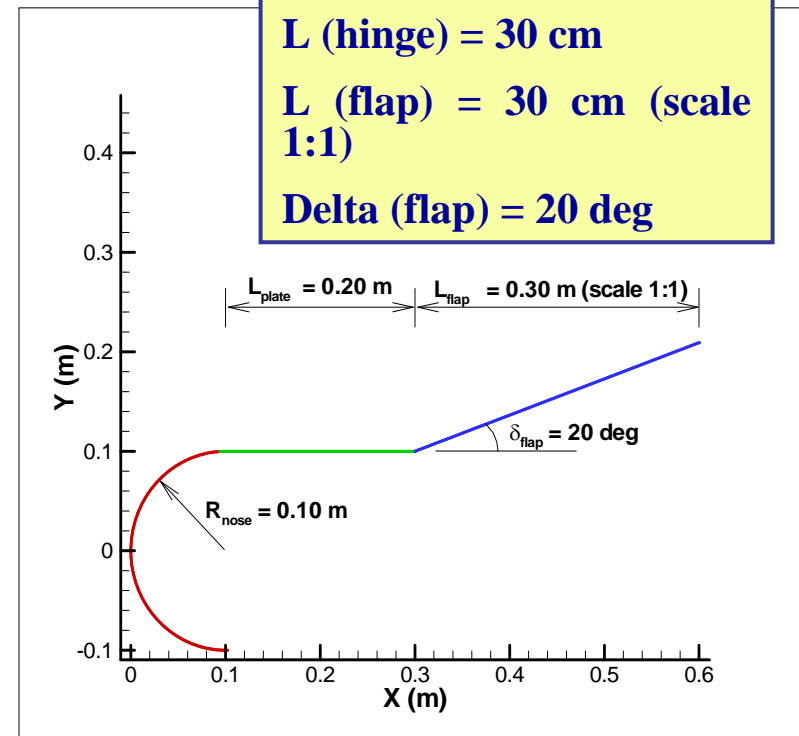
Flap 2



## Test in Scirocco - Model Definition



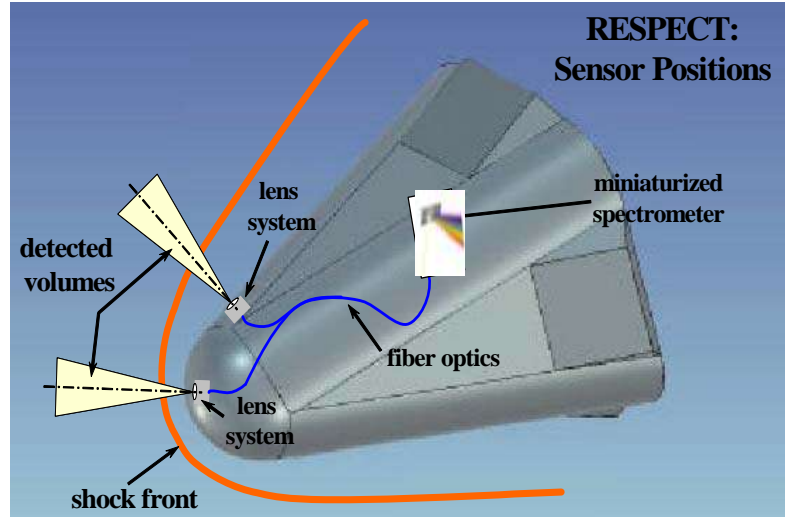
**R (nose) = 10 cm**  
**L (hinge) = 30 cm**  
**L (flap) = 30 cm (scale 1:1)**  
**Delta (flap) = 20 deg**



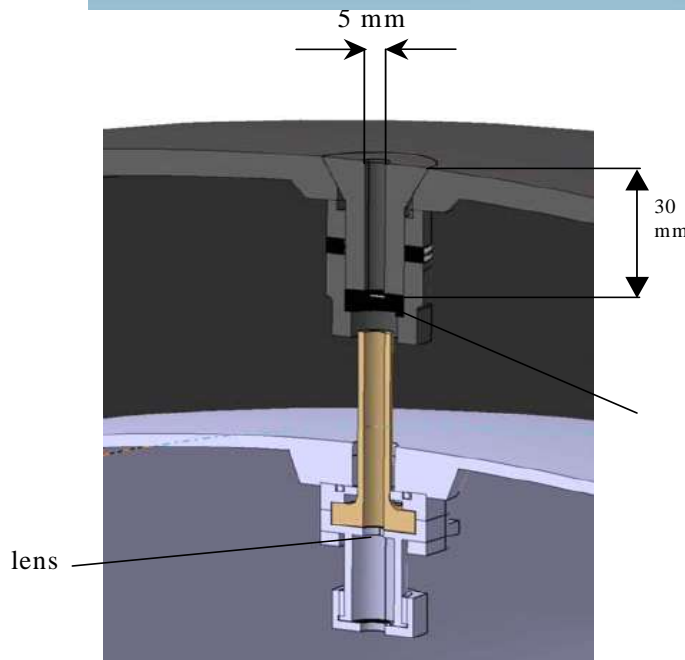
Materials have been selected to be consistent with EXPERT specifications:

- PM1000 for the flat plate
- C-SiC for the flap

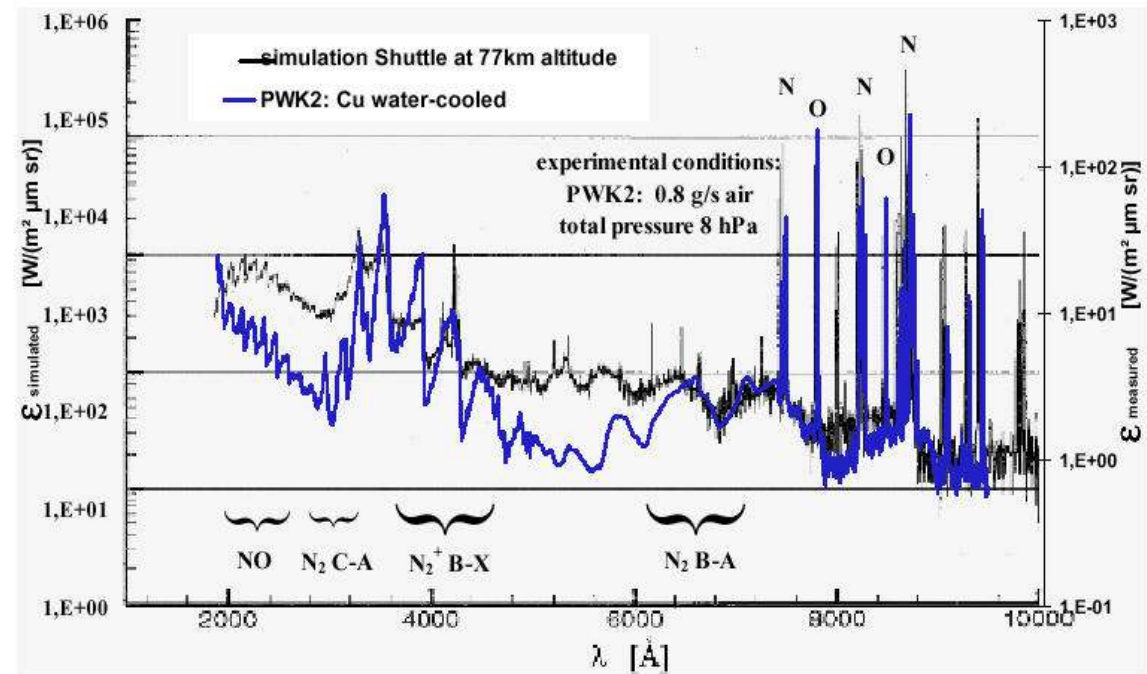
Nose built with Copper Actively Cooled



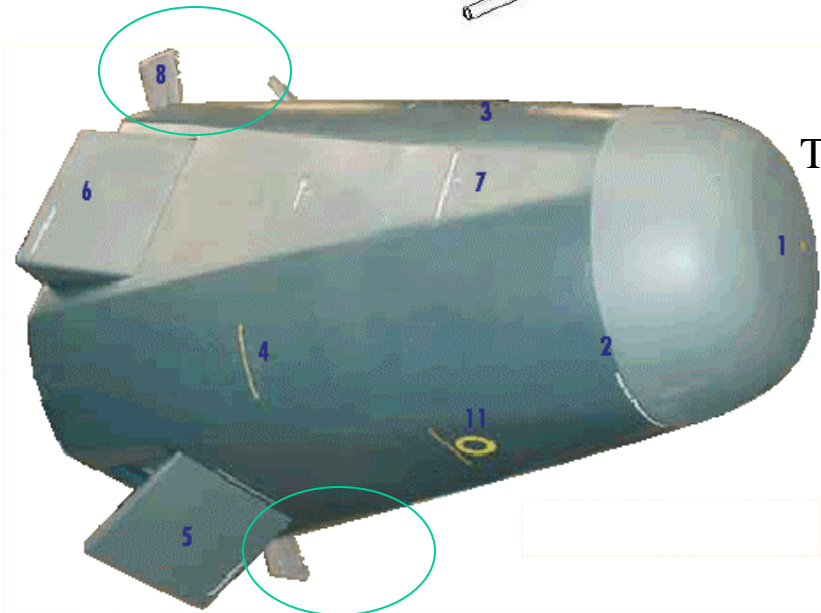
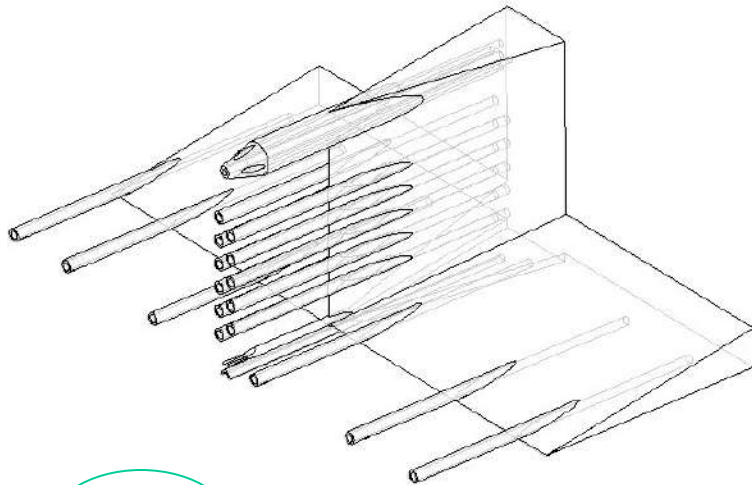
# RESPECT Emission



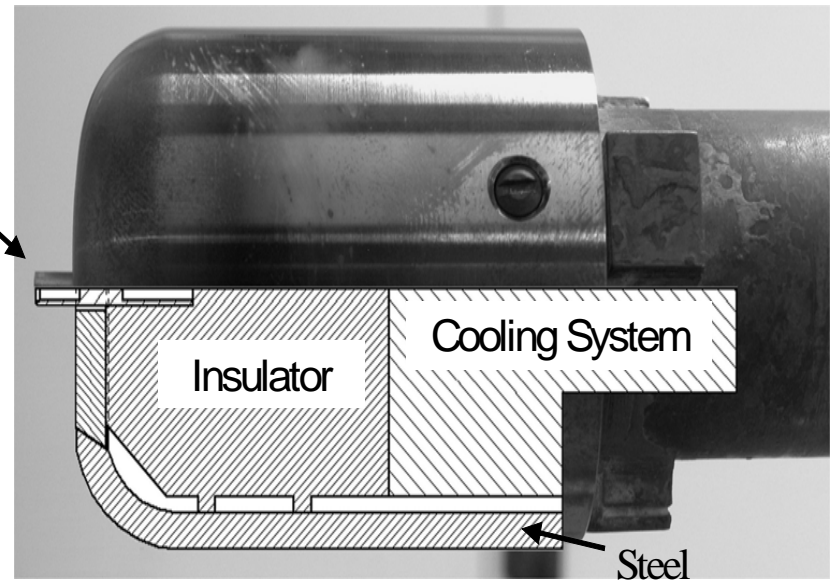
sapphire window: thickness 3 mm, diameter 14 mm



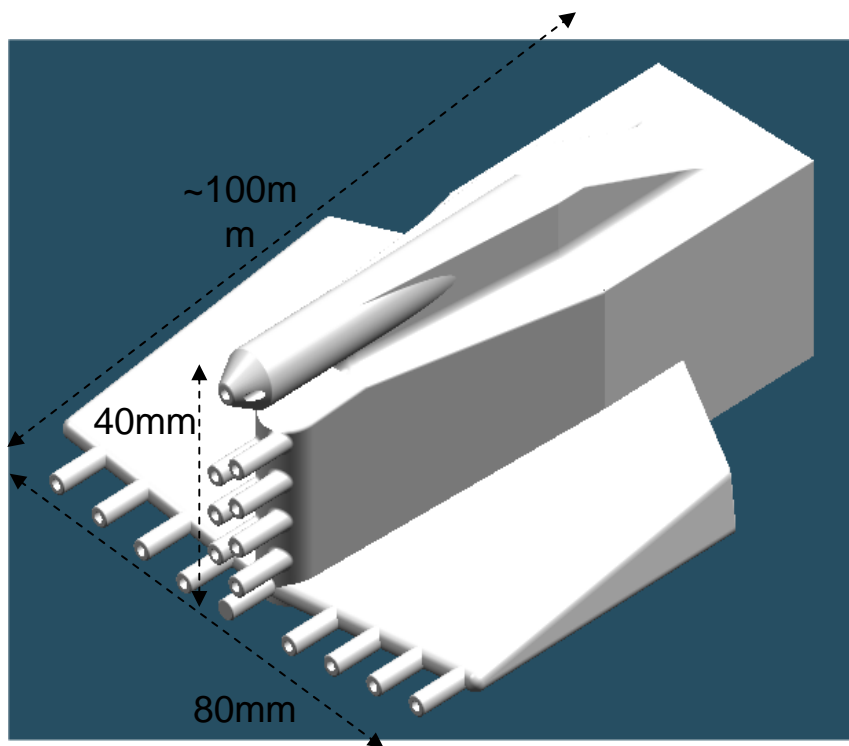
# Pitot Static Rakes



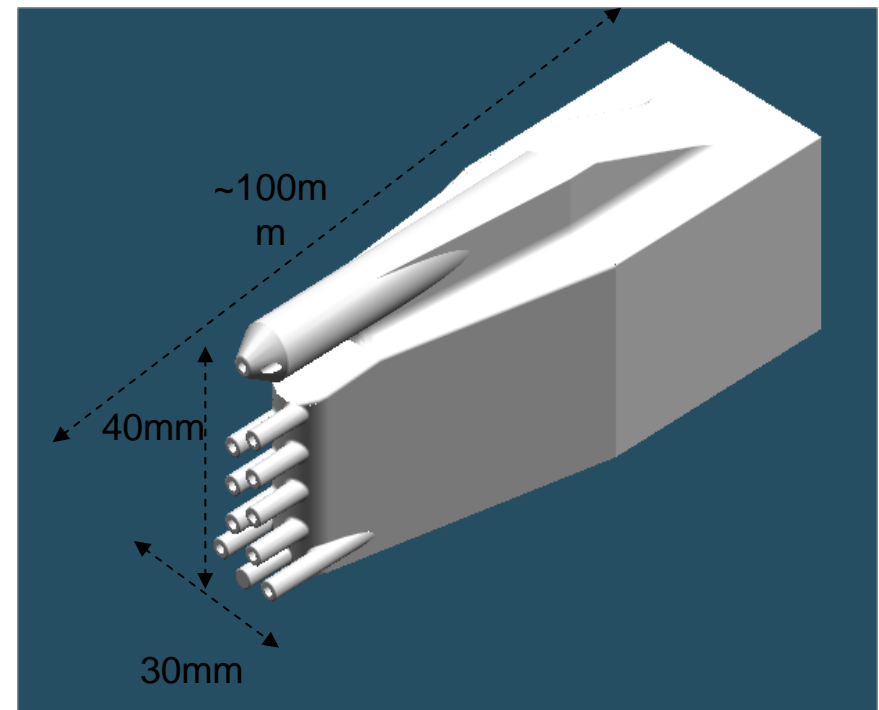
Tungsten tube



## Pitot Static Rakes

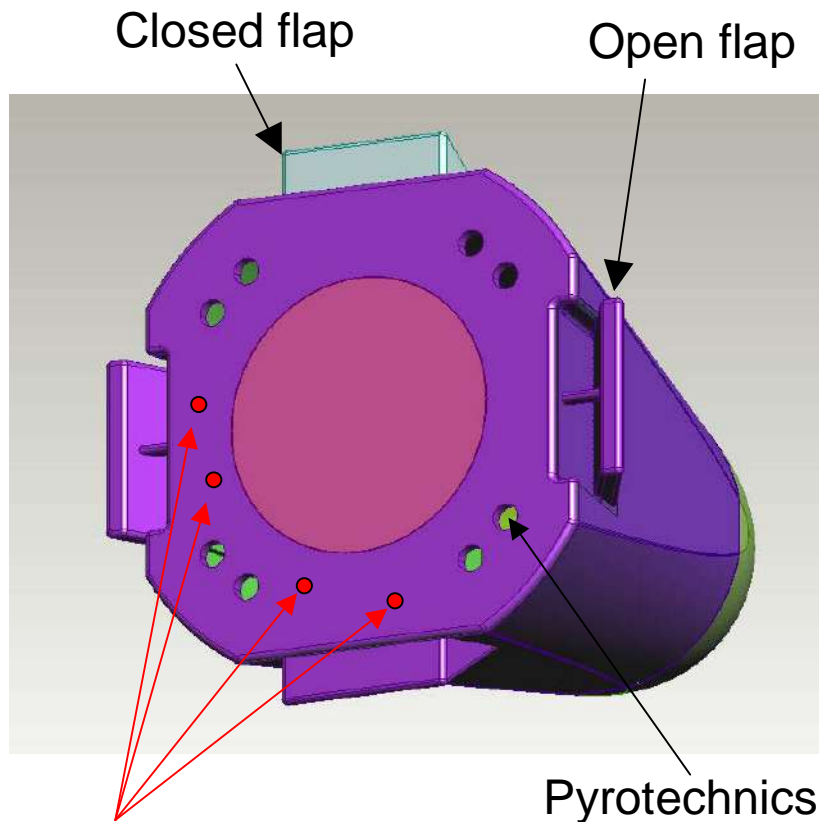


High resolution version



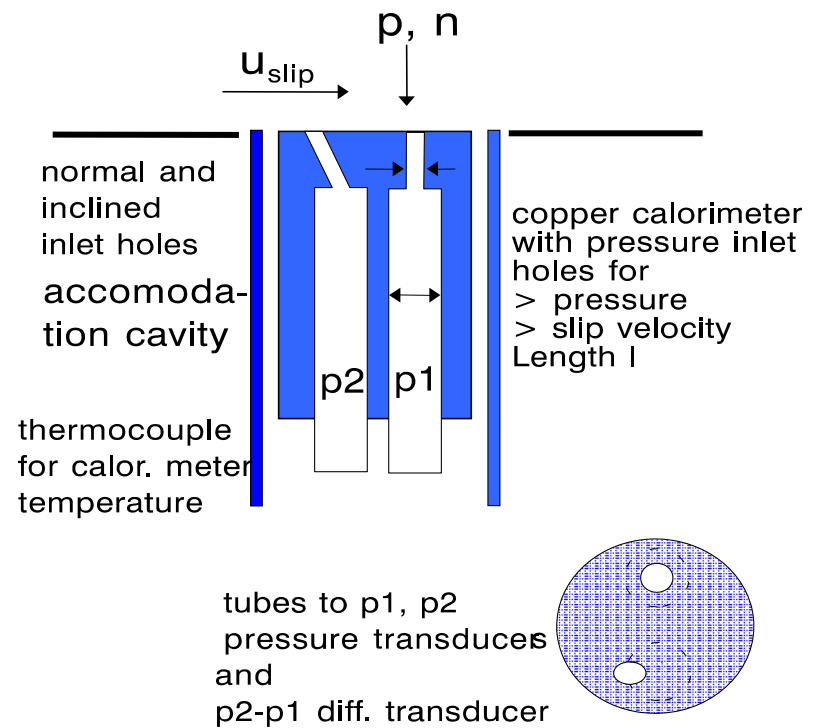
Low resolution version

# Base and slip flow measurements

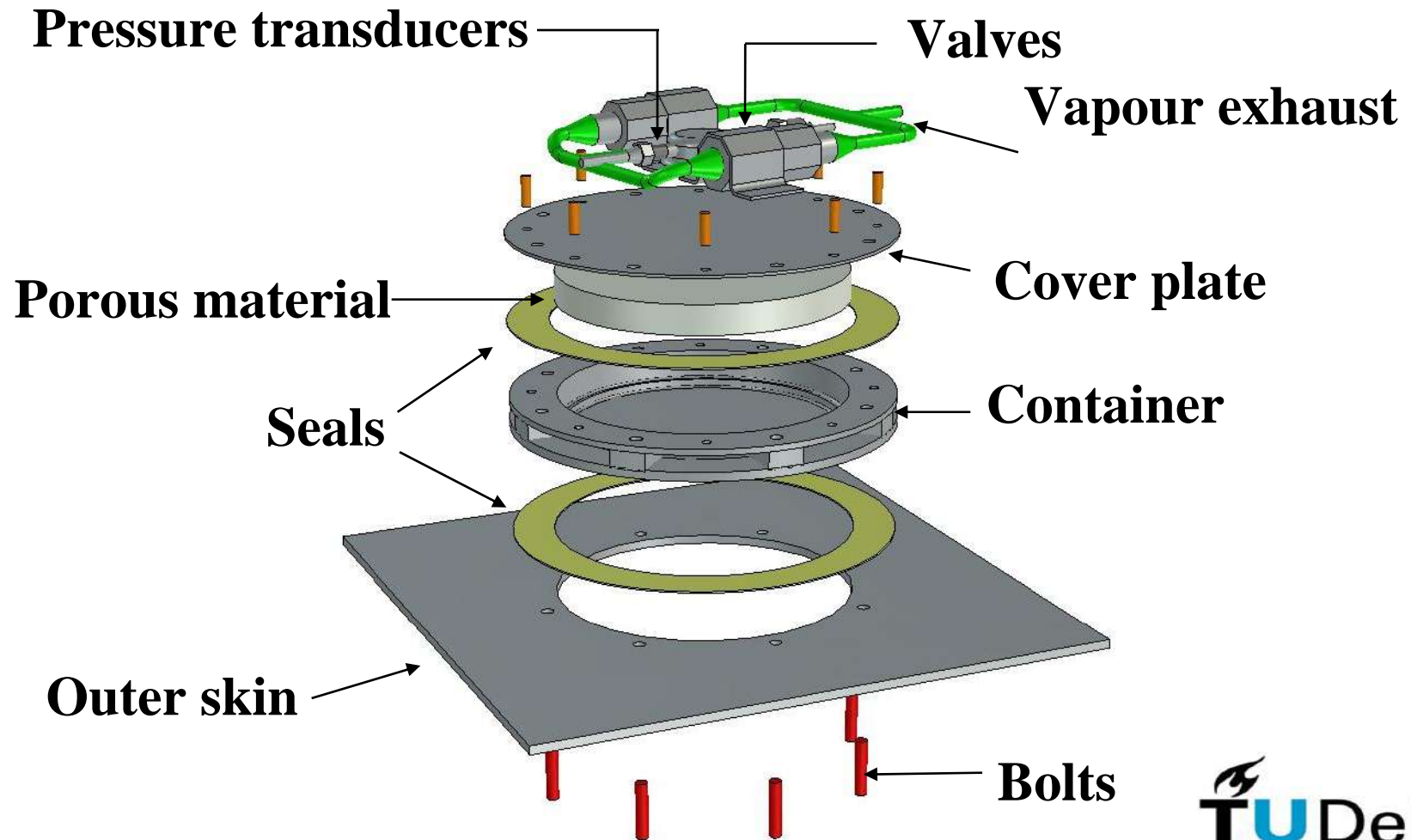


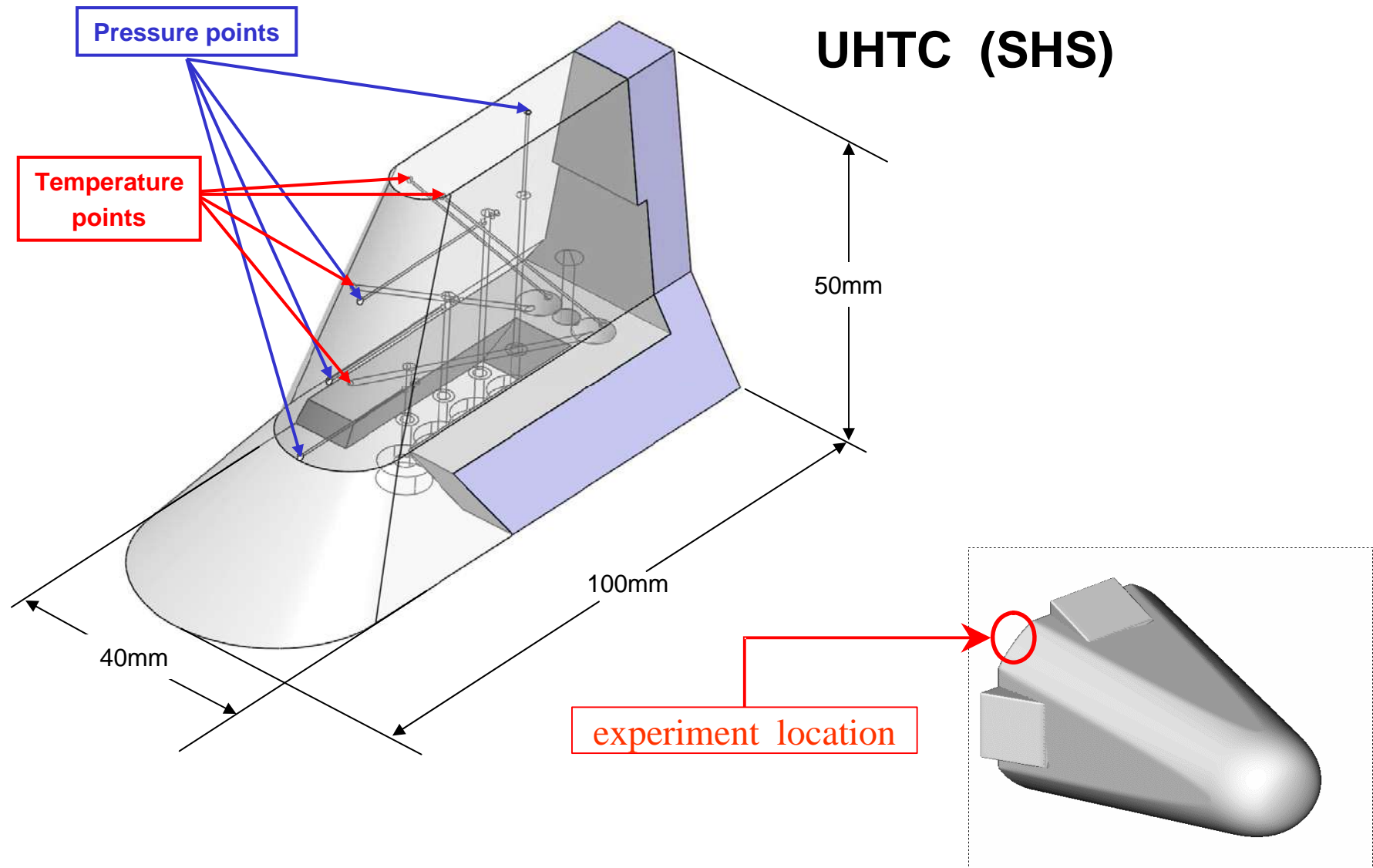
Possible Sensor Unit positioning

The Combined Slip- Flux Probe, CSFP (slip velocity, heat flux, surface pressure)

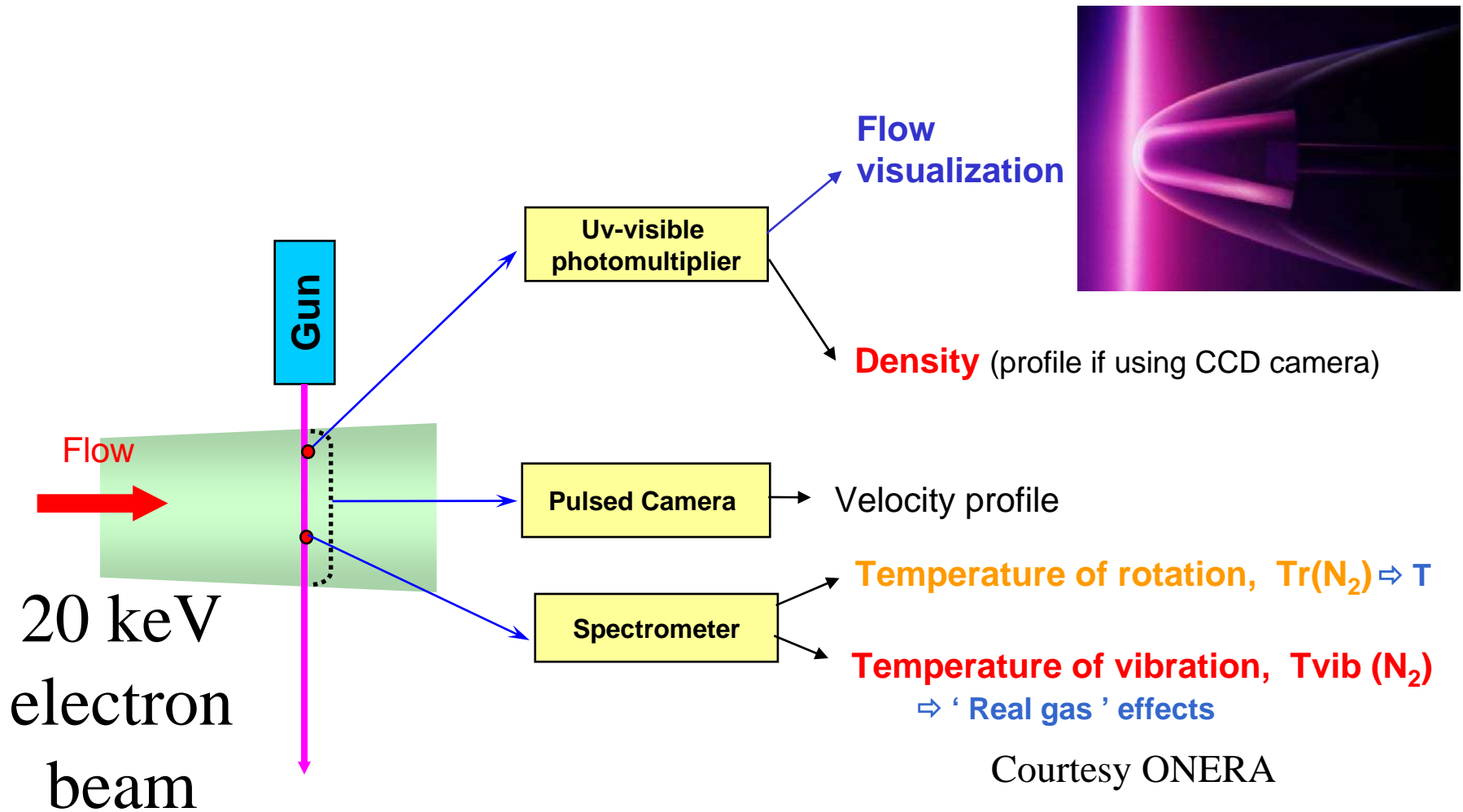


# TUD Passenger Experiment : Enhanced Radiation Cooling

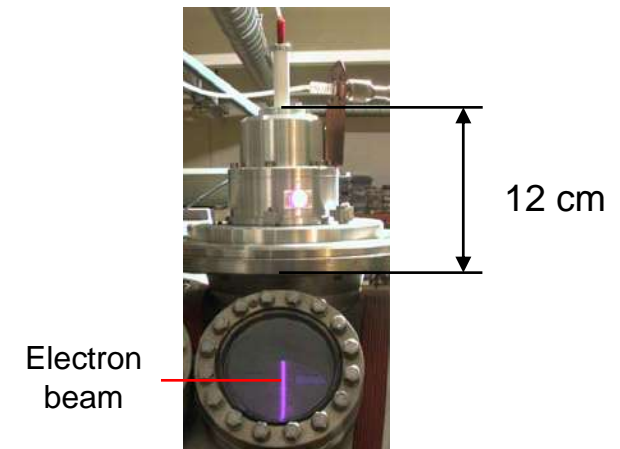
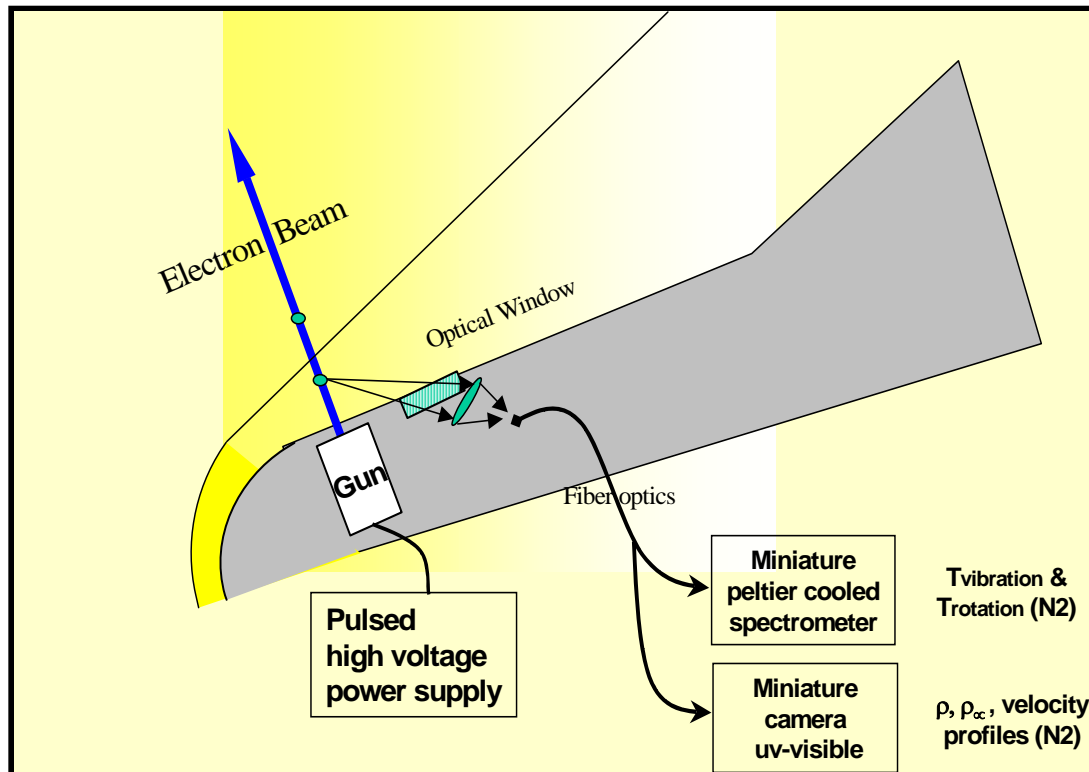




## Electron beam fluorescence



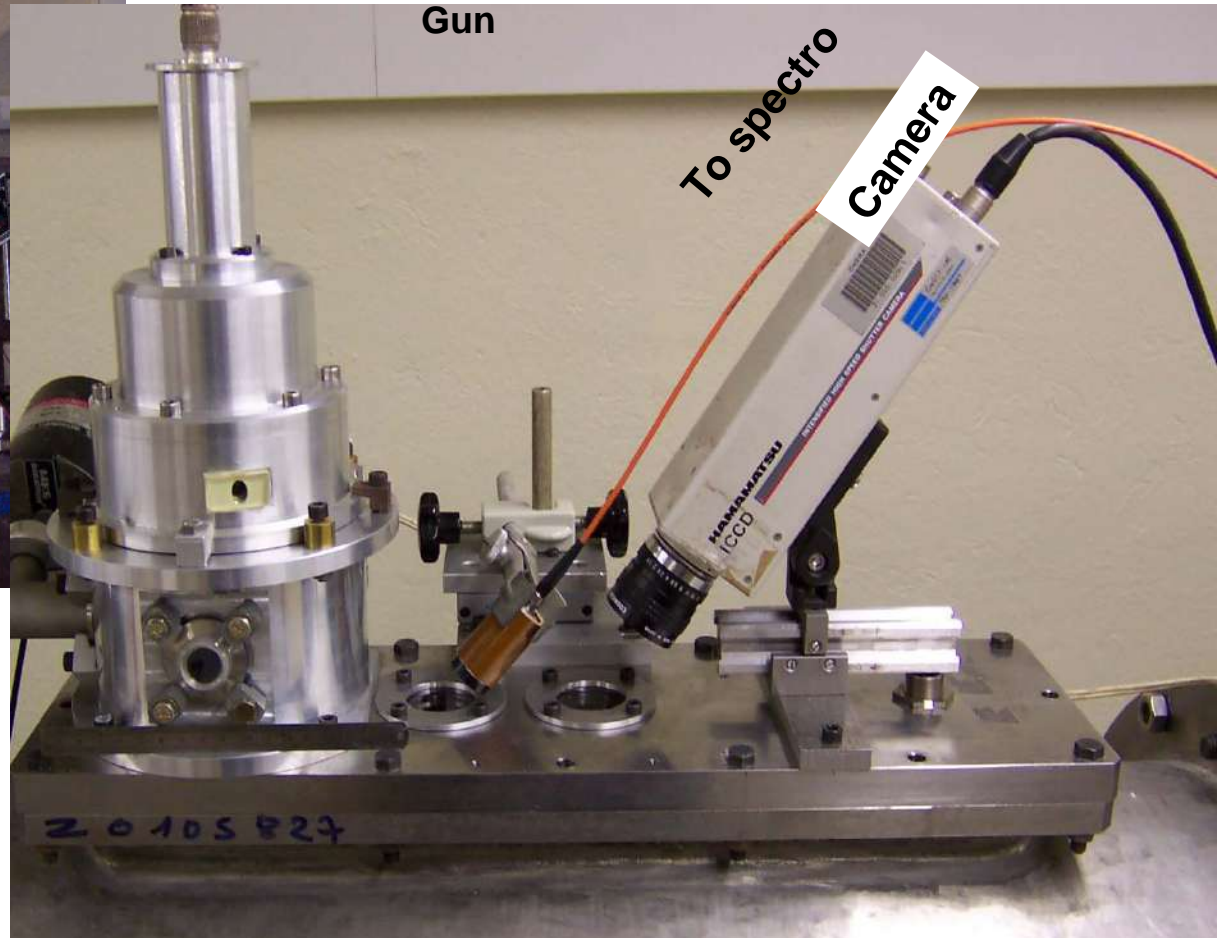
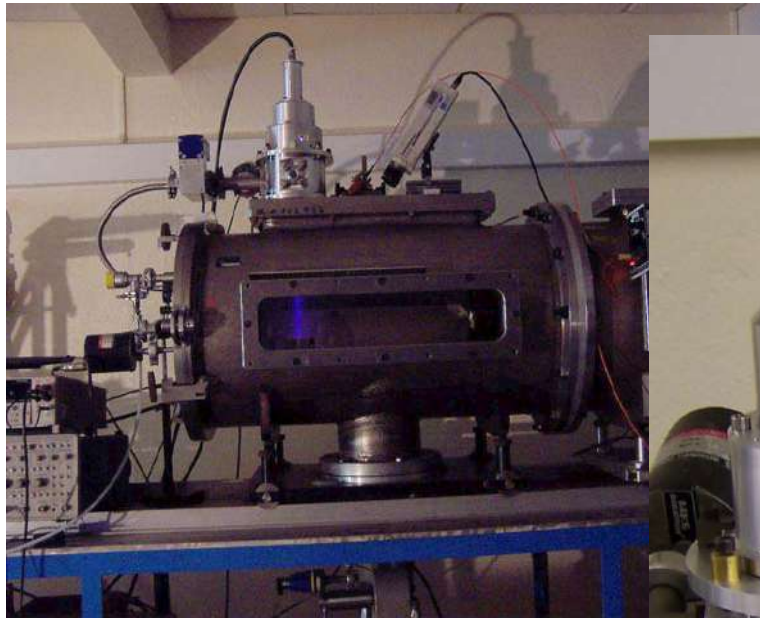
## In-flight EBF setup proposed



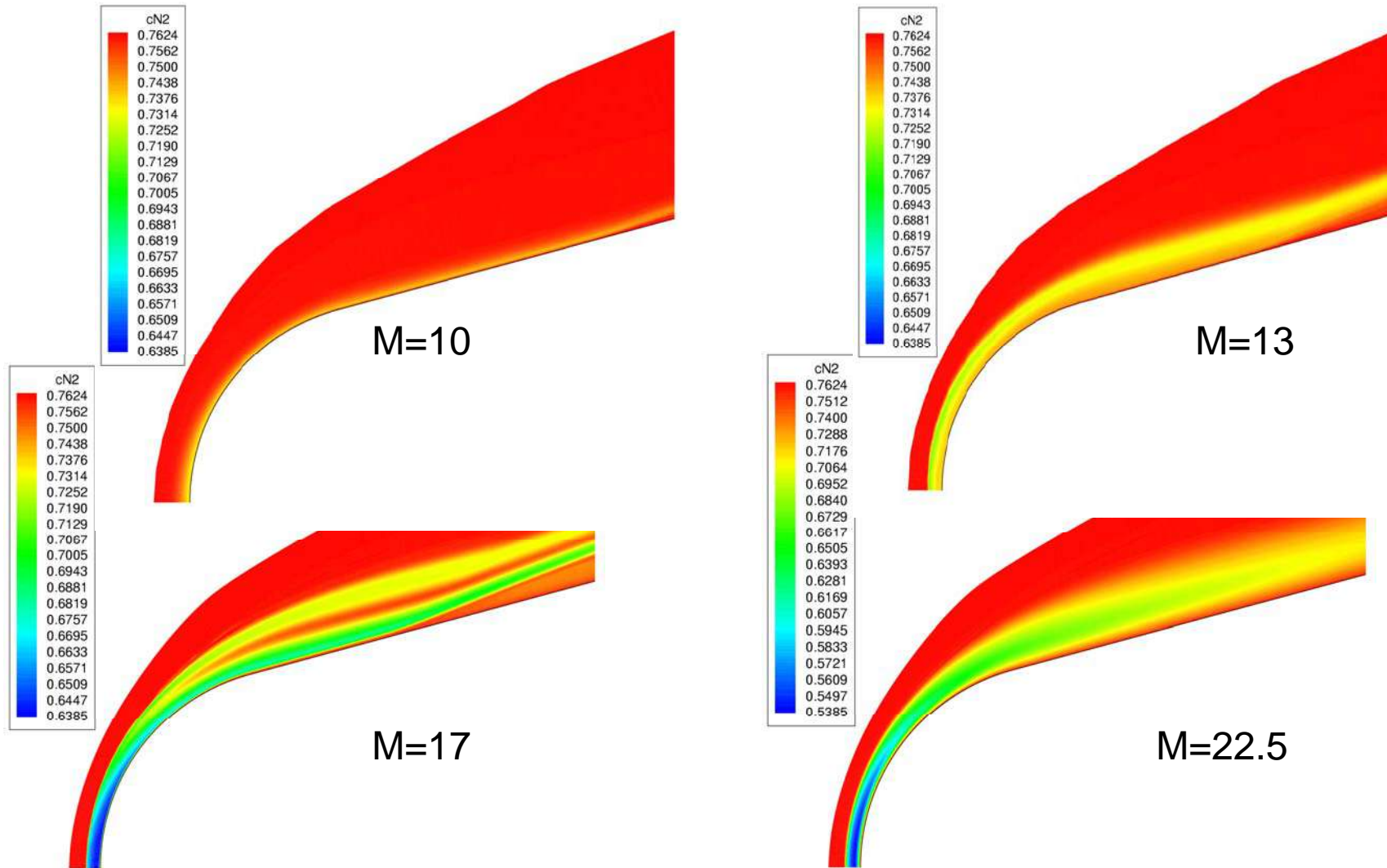
Miniaturised electron gun prototype

- ↓ ⇒ **Need a miniaturised electron gun**
- ↓ ⇒ **On-going development at ONERA (PRF MH)**

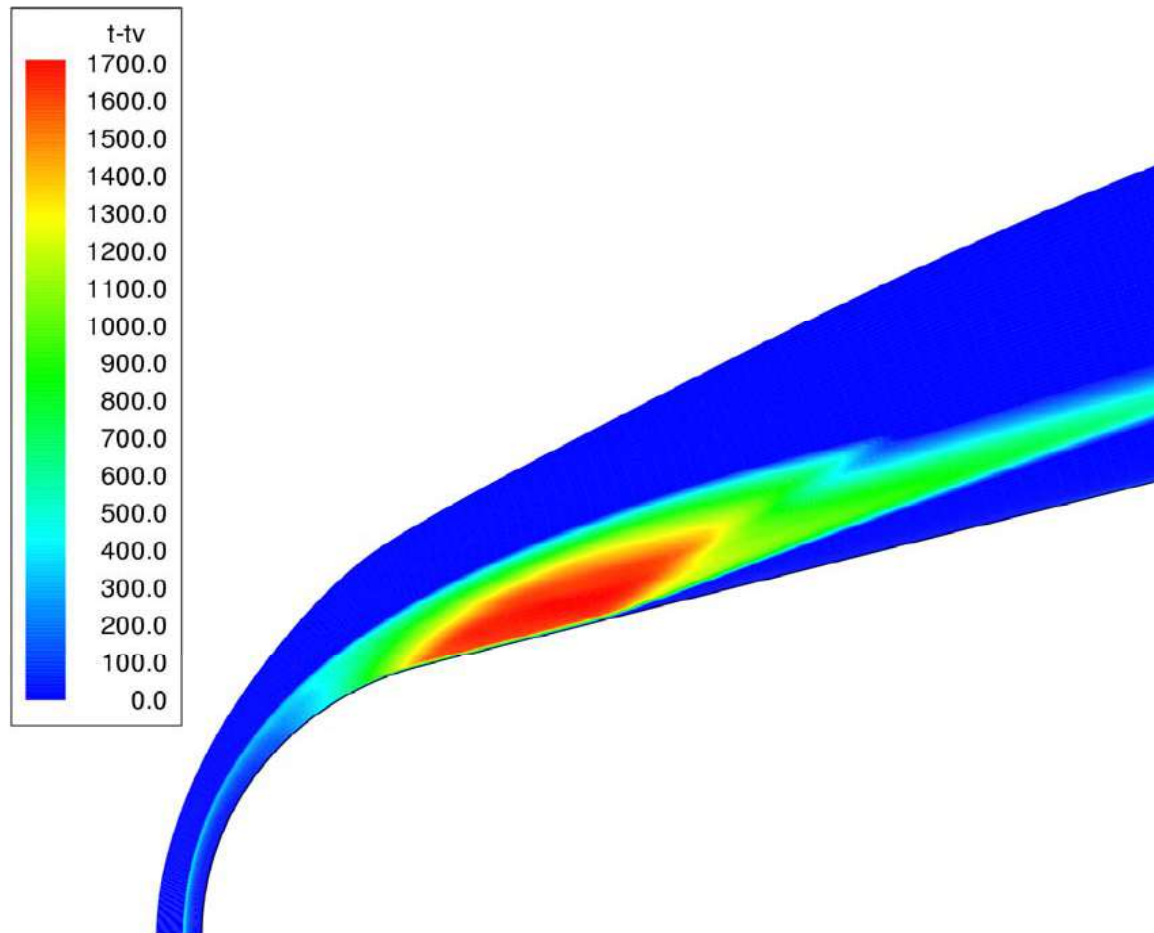




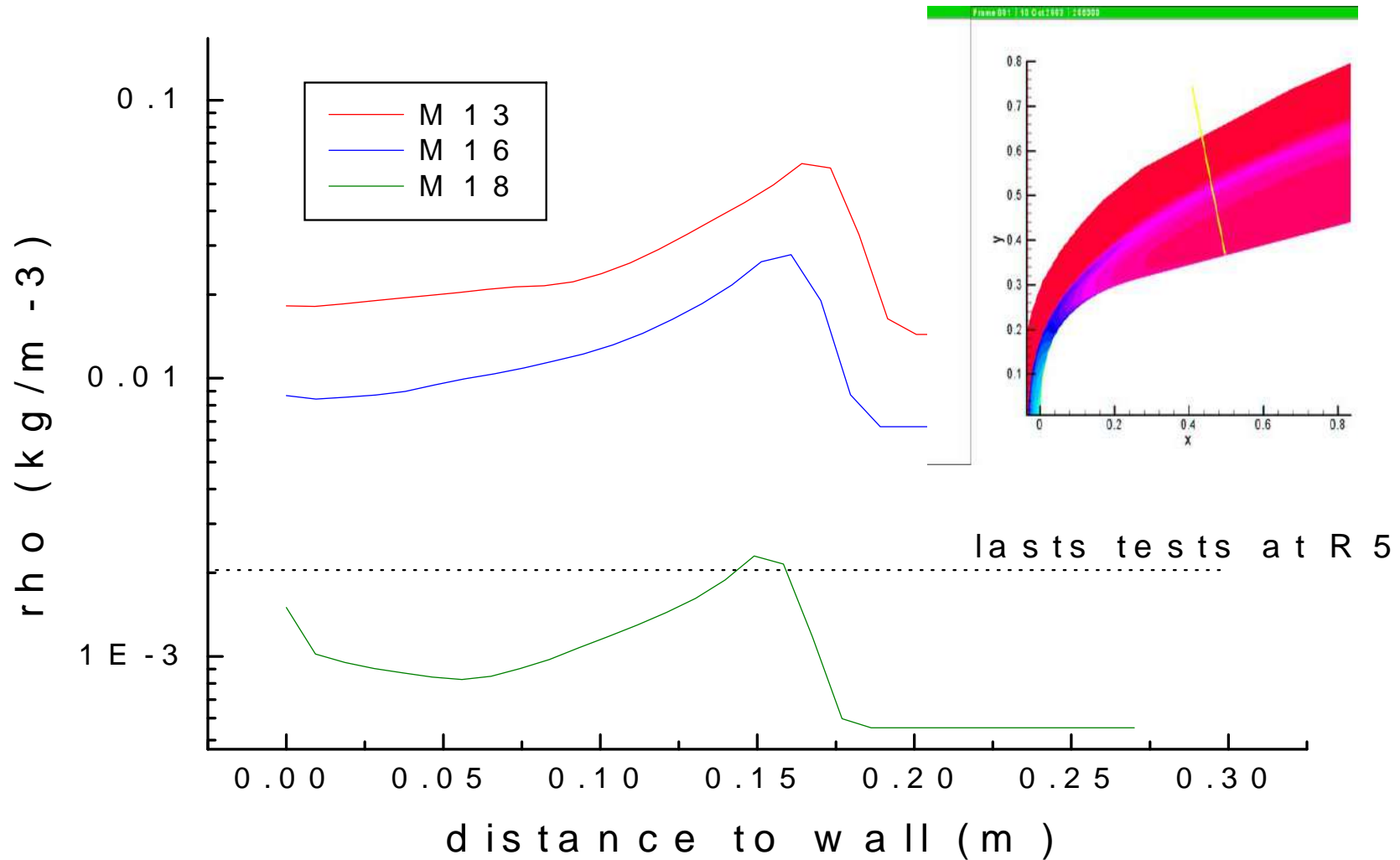
# N<sub>2</sub> concentrations



## T-T<sub>v</sub> at M=17, non-catalytic



## EBF density range (ONERA)



## **CONCLUSION**

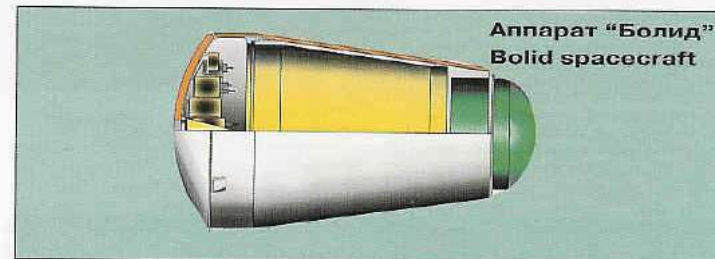
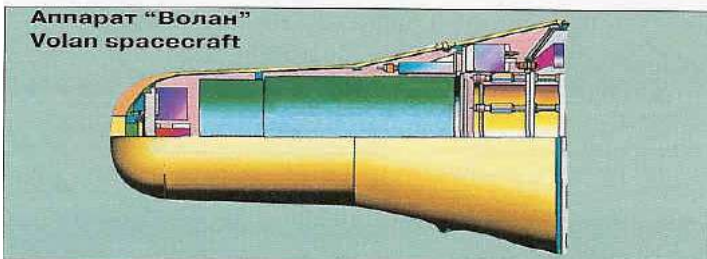
- 1) EXPERT IS A FLIGHT TEST BED TO PROVIDE ATD DATA SO AS TO IMPROVE THE ATD TOOLS FOR DESIGN BY FLYING CRITICAL ATD PROBLEMS ON GENERIC CONFIGURATIONS, ANALYSE THEM IN IN-GROUND BASED FACILITIES AND CONSOLIDATE WINDTUNNEL TO FLIGHT EXTRAPOLATION METHODS USING CFD.**
- 2) THE KEY POINT OF THE EXPERT TESTBED IS THE FLEXIBILITY OF SUBMARINE LAUNCHED VEHICLE WHERE TRAJECTORY (FLIGHT PATH ANGLE, REENTRY SPEED AND POSITION OF SUBMARINE) CAN BE SELECTED TO “GO AFTER THE ATD PROBLEMS FOR DESIGN” .  
MASS FROM 250 Kg to 450Kg, DIMENSIONS 0.55 m DIAMETER NOSE, 1.4m DIAMETER TAIL AND LENGTH UP TO 1.7 m, THEREBY KEEPING LAUNCH AND RECOVERY COSTS LOW**

## **CONCLUSION CONT'D**

**3) THE EXPERT PROGRAMME COULD PROVIDE OPPORTUNITIES FOR FOLLOW UP FLIGHTS TO AUGMENT THE ATD HYPERSONIC DATA BASE WHERE GROUND BASED FACILITIES ONLY PARTIALLY SIMULATE THE EFFECTS AND/OR WHERE TRL LEVELS REQUIRES SYSTEM OR SUBSYSTEM FLIGHT QUALIFICATION. E.G.**

- **FUTURE LAUNCHER PREPARATORY PROGRAMME**
- **ISS DLS**
- **PLANETARY SCIENCE**
  - **HIGH SPEED DIRECT REENTRY RESEARCH ;ABLATION**
  - **AEROCAPTURING PHYSICS**
- **ADVANCED INSTRUMENTATION; NON INTRUSIVE MEASUREMENT TECHNIQUES**
- **MHD , RCS INTERACTION,**
- **SHARP LEADING EDGE OR SHARP NOSE ADVANCED MATERIAL**

## Volan and Bolid



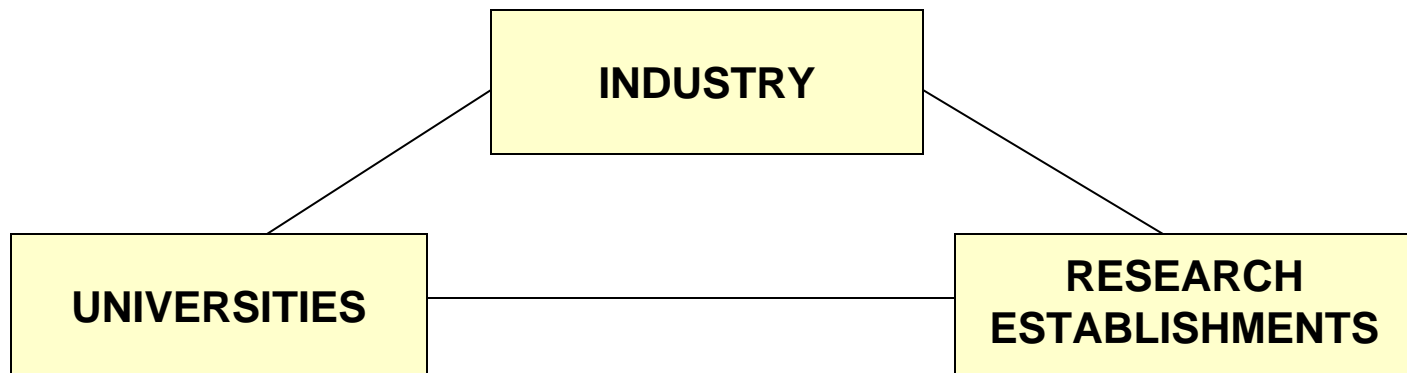
Основные тактико-технические характеристики		
	"Волат"	"Болид"
Тип аппарата		
Масса, кг:		
аппарата	650	720
исследовательской аппаратуры	200-220	до 400
Объем исследовательской аппаратуры, дм <sup>3</sup>	250	до 700
Время невесомости, мин	до 30	до 29
Уровень микрогравитации, g	10 <sup>-5</sup> - 10 <sup>-6</sup>	

Basic Characteristics		
	Volan	Bolid
Spacecraft type		
Weight, kg:		
of spacecraft	650	720
of research equipment	200 to 220	400, max.
Volume of research equipment, dm <sup>3</sup>	250	700, max.
Time of stay in zero-gravity state, min	30, max.	29, max.
Level of microgravitation, g	10 <sup>-5</sup> to 10 <sup>-6</sup>	

## Course Roadmap

- **Flight Experimentation Logic**
- **Motivation for in flight research**
- **EXPERT**
- **Vehicle and Flight instrumentation**
- **Conclusions**

# EXPERT PROJECT PROMOTES NETWORK FOR IMPROVEMENTS OF ATD TOOLS FOR DESIGN



**+ HARMONISATION WITH ONGOING NATIONAL PROGRAMMES**

# IN FLIGHT EXPERIMENTATION STRATEGY

## 1. FULL SCALE 1 FLIGHT :

- e.g. - SHUTTLE, BOURANE, APOLLO, SHENZHOU, ARIANE 5, HUYGENS
- HOPE, HERMES, OSP
  - HERCULES, SOCRATES

## 2. EXPERIMENTAL DEMONSTRATOR VEHICLES :

- e.g. - X23, X24, X38, AS201, AS202, APOLLO 4,6 ARD,
- BOR4 for TPS ; BOR5 for GNC;
  - OREX, HYFLEX for TPS ; ALFEX for GNC
  - MAIA, PHOENIX 1 and 2 for GNC
  - FLPP IXV ( PRE-X – USV )

## 3. IN FLIGHT RESEARCH VEHICLES

- e.g. - SHARP B1, B2 FLIGHTS, HYSHOT, X43,
- IRDT, PAET, RAMC, FIRE
  - MIRKA, EXPRESS, *SHEFEX*, SFYFE
  - EXPERT