

Design. Manufacture. Install.
Specialising in Rendering & Process Equipment

SIDE ENTERING AGITATOR

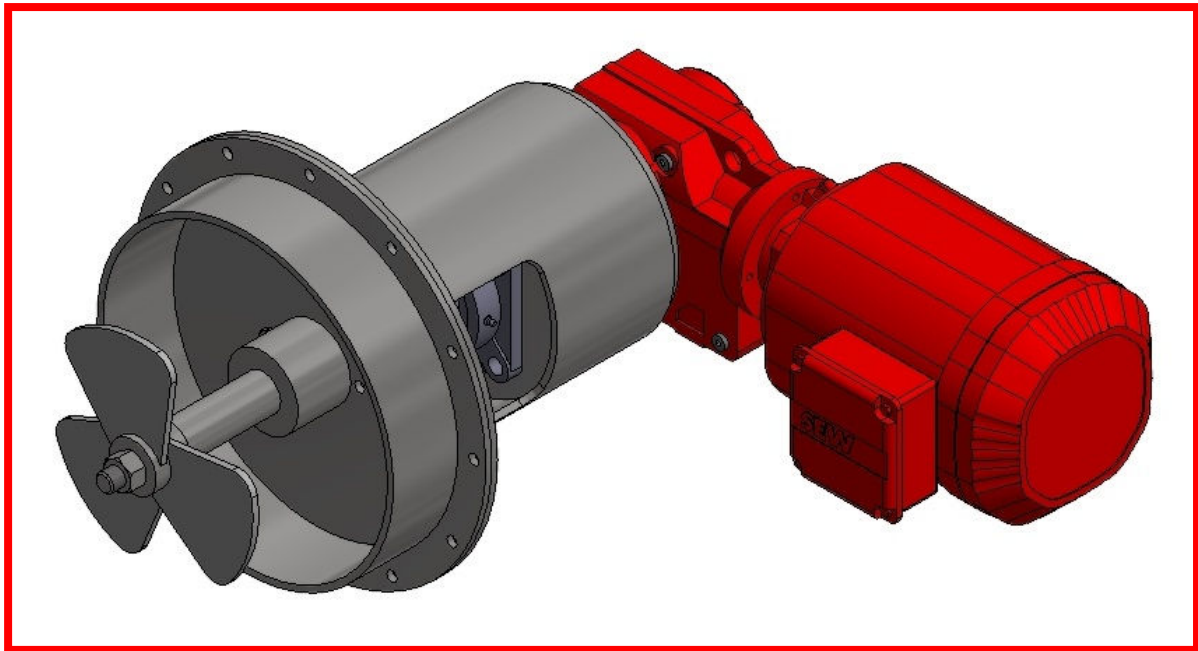

**FOR DIRECT MOUNTING THROUGH WALLS OF
PROCESS VESSELS AND STORAGE TANKS**

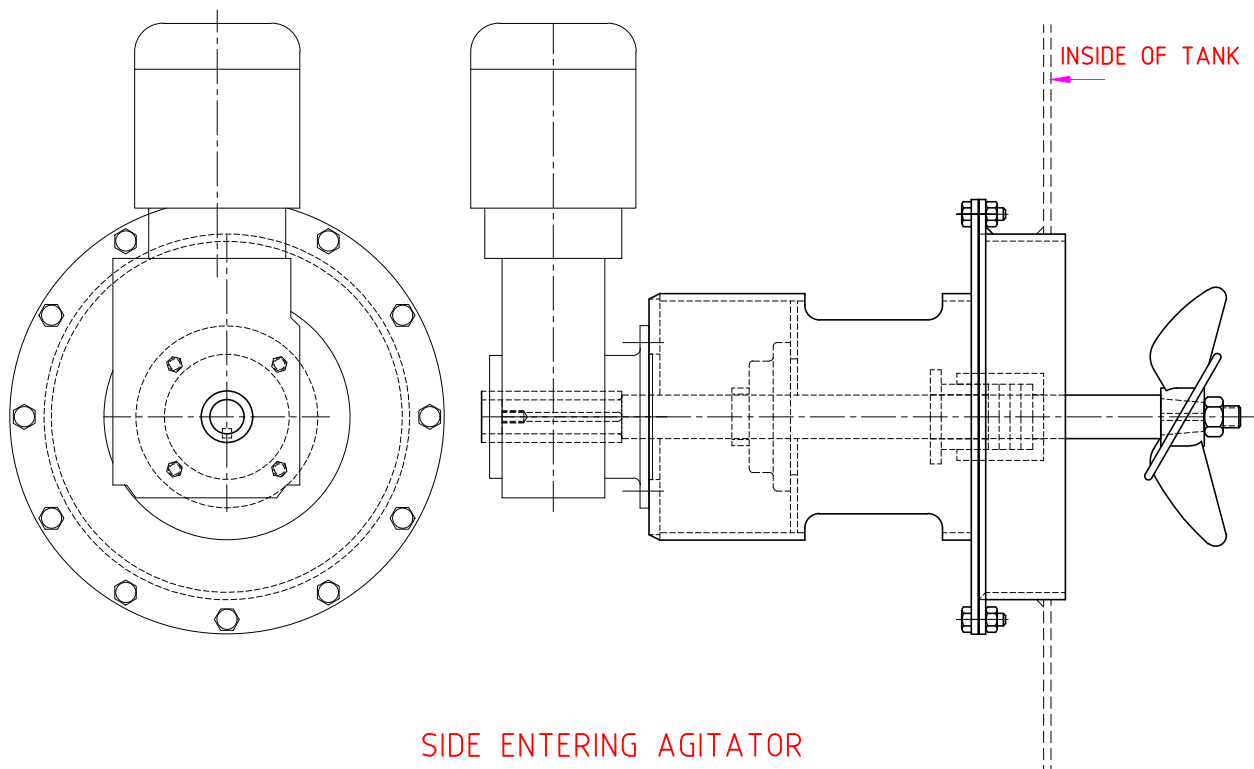

- . Greater agitation where it matters, at the bottom of the vessel.
- . Simple installation, even into existing plant.
- . Robust all steel construction.
- . Packed gland shaft sealing arrangement.
- . Avoids messy problems associated with vertical, extended spindle agitators.

SPECIAL SIZES AND TYPES MAY BE BUILT TO
CUSTOMER'S SPECIFICATION
AVAILABLE IN 2.2 kW AND 4 kW



Keith Engineering (Australia) Pty. Ltd.
20 Kellet Close, Erskine Park, NSW
PO Box 354, St. Clair
NSW 2759

T 02 9852 1000
F 02 9852 1001

admin@keitheng.com.au
www.keitheng.com