

Design. Manufacture. Install.

Specialising in Rendering & Process Equipment

BATCH COOKERS



**FOR BATCH PROCESSING ANY ANIMAL BY
PRODUCT IN OPEN VENT OR PRESSURE
COOKING APPLICATIONS, INCLUDING
FEATHER, WOOL AND HAIR HYDROLYSING**

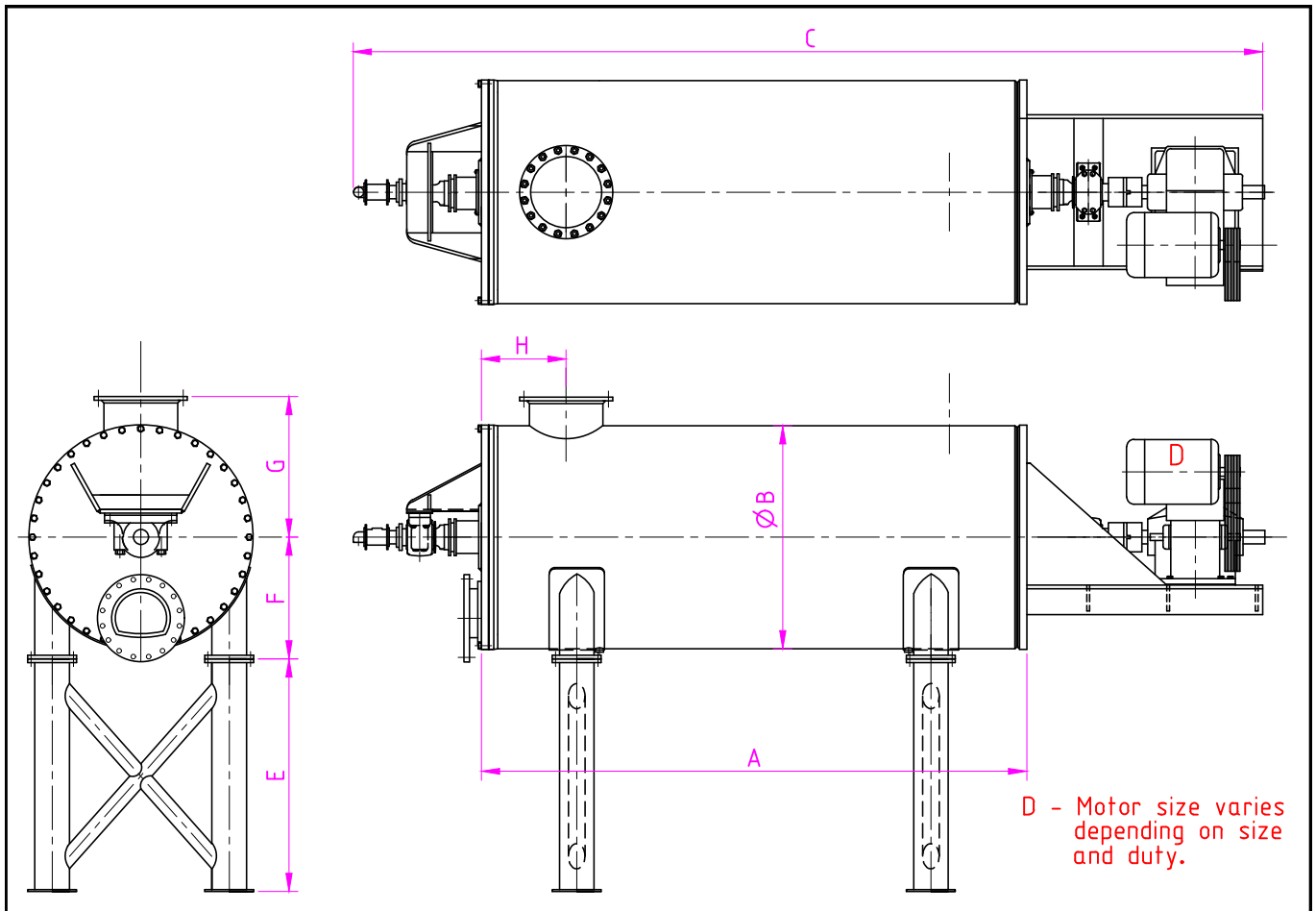

COOKER SIZE	A	B	C	E	F	G	H	CAPACITY IN Kg.	
								COOKER	HYDROLYSER
125	3755	1540	6265	To suit	840	965	To suit	3500	3000
145	4365	1540	6875	To suit	840	965	To suit	4000	3500
165	4900	1540	7835	To suit	913	1075	To suit	4500	4000
205	6120	1540	9055	To suit	913	1075	To suit	6000	5000

Some available options are: -

- . Inlet and Outlet gate.
- . Position of charging neck to suit customer requirements.
- . Necessary pipe work, gauges, valving and controls needed to hydrolyze feathers, wools, pig hair or pressure cook
- . A solid shaft can be supplied and fitted instead of the conventional steam heated shaft.
- . Designed, manufactured and tested to the AS 1210 CODE -1989.
- . Approved and supervised by the Work Cover Authority of N. S. W.