

Design. Manufacture. Install.
Specialising in Rendering & Process Equipment

HAMMER MILL

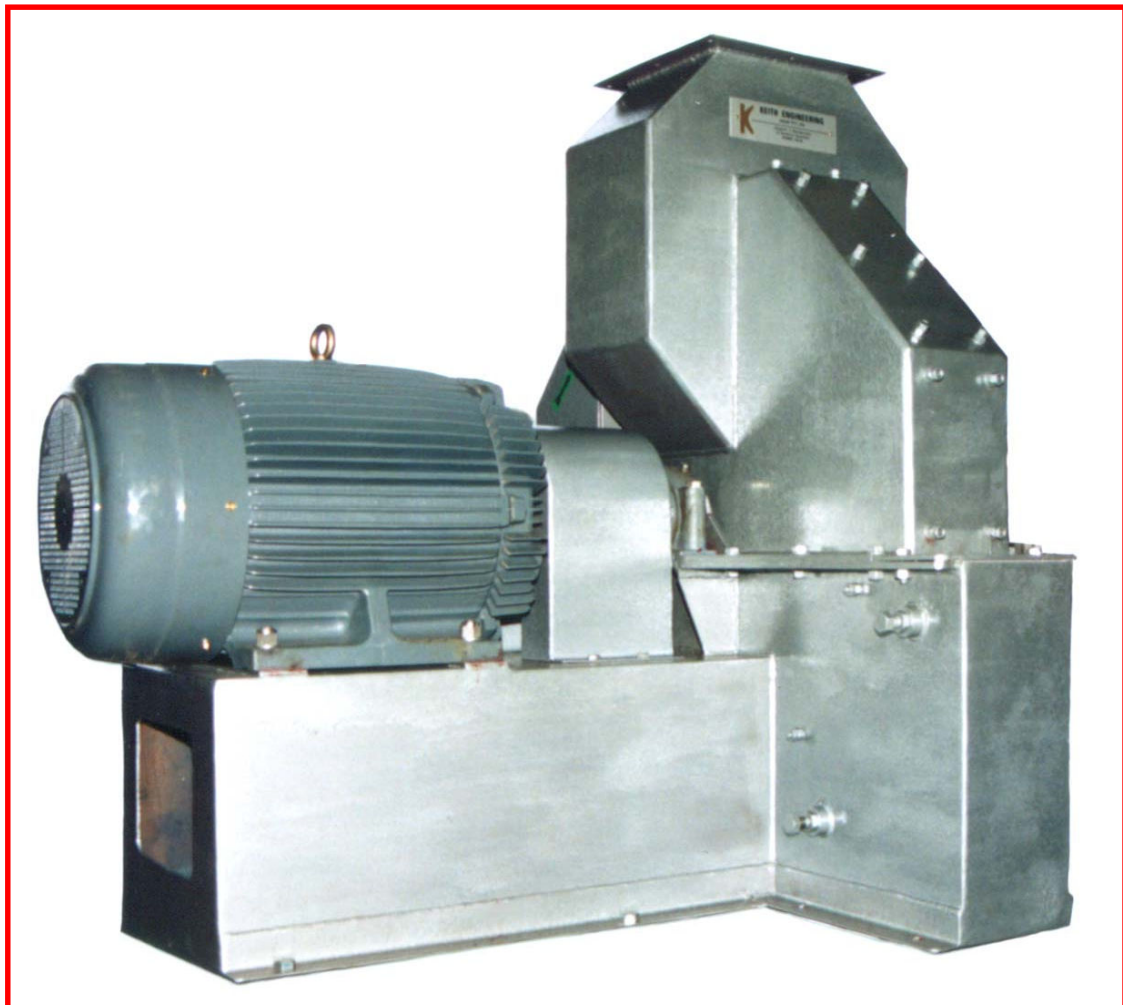

**FOR PROCESSING MATERIAL WHERE
SATISFACTORY BREAKUP BEFORE FINAL
SCREENING IS REQUIRED**

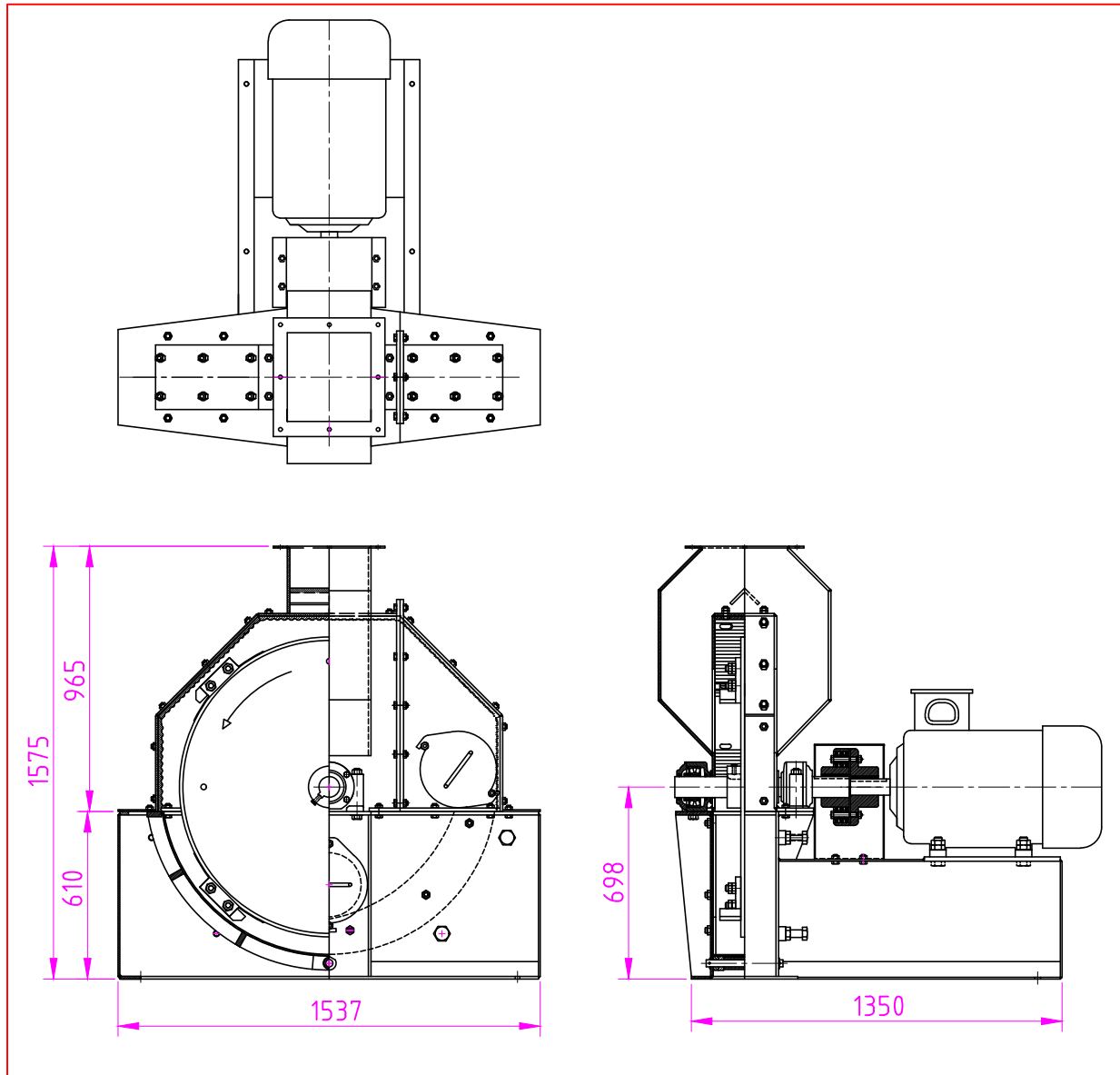

- . Solid Rotor plate
- . 4 Fixed easy to change non-swinging hammers
- . Access door simplifies hammer changing
- . Robust construction
- . Easy screen replacement
- . Operates at standard 1440 rpm
- . Removable hard faced or cast hammers
- . Base accommodates motor up to 90 kW
- . Base made to fit over any size screw conveyor
- . Lined with easily replaceable wear plates