

Design. Manufacture. Install.
Specialising in Rendering & Process Equipment

PERC PAN

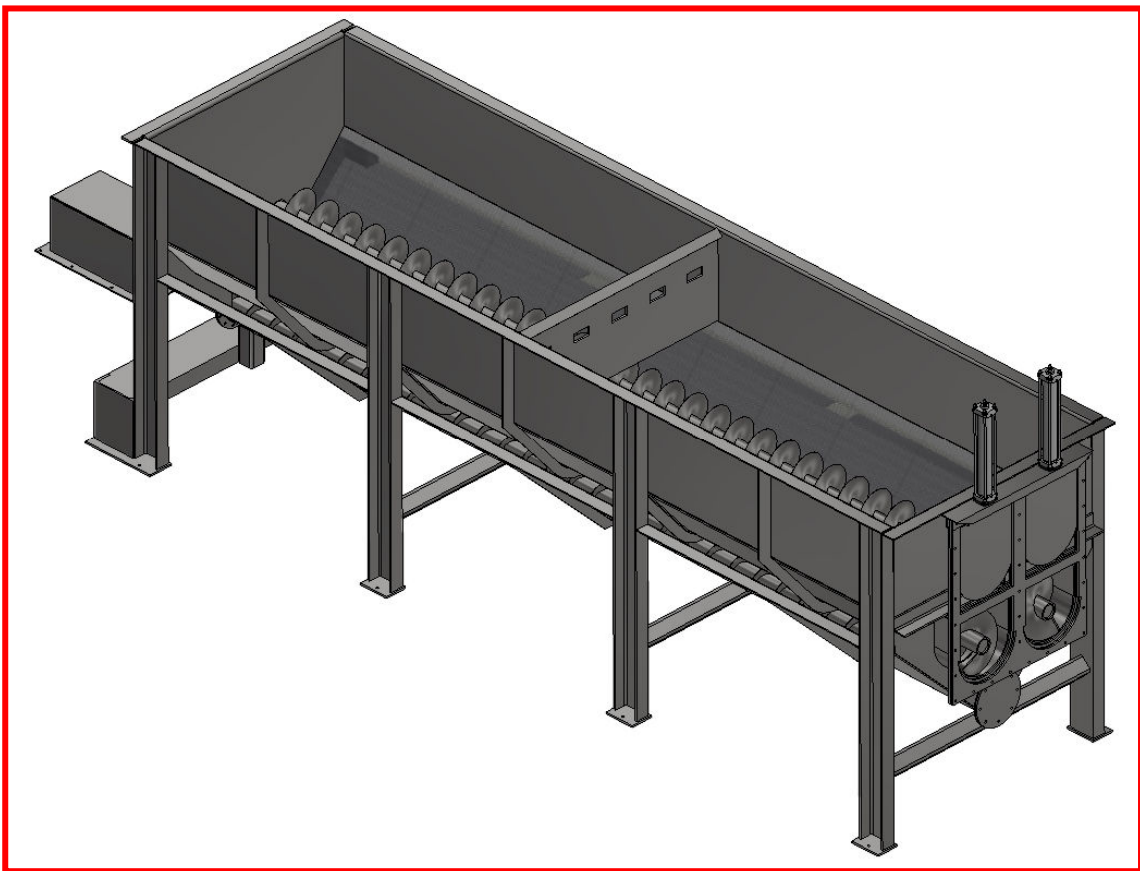

**FOR RECEIVING COOKED CRACKLINGS
AND TALLOW FROM DRY RENDERING
BATCH COOKER**

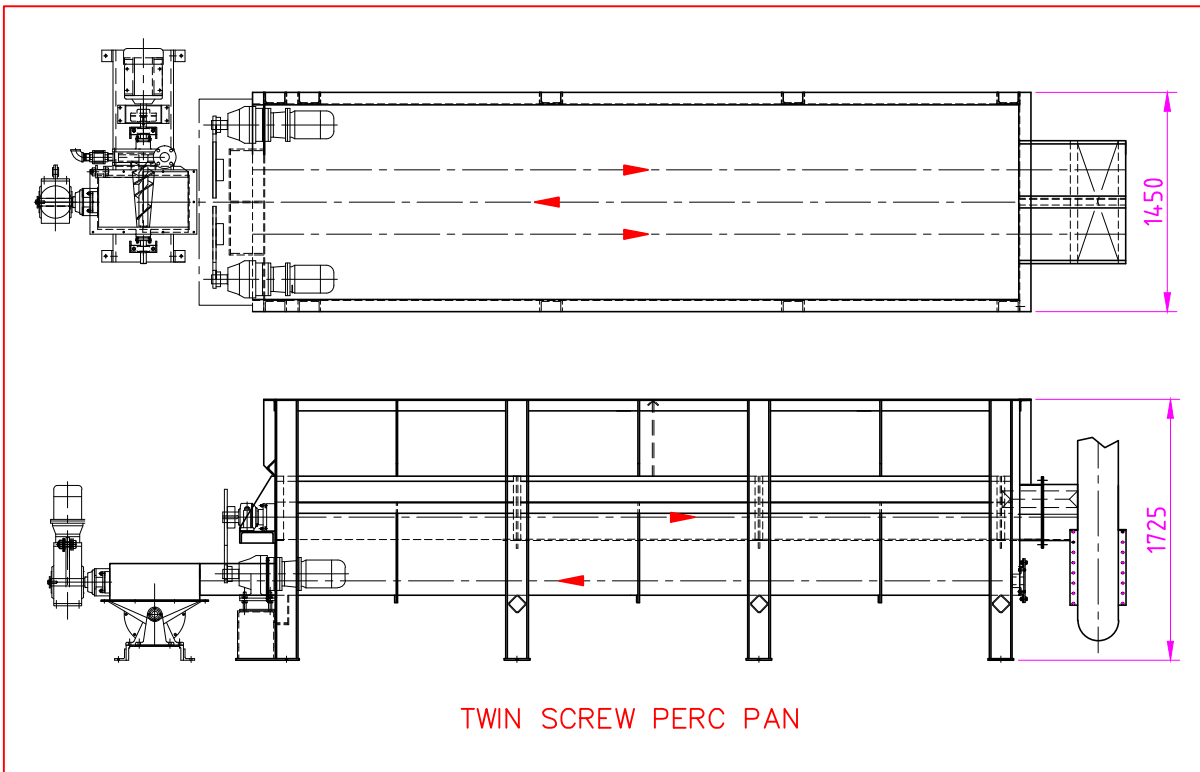

The Perc Pan is designed to receive cooked cracklings and tallow from dry rendering Batch Cookers. Tallow drains through a perforated bottom into a collection pan and cracklings are discharged by a twin screw conveyor. The perc pan can accommodate full load of cooked product from single or multiple batch cooker operations.

Fabricated in 6mm thick mild steel plate.

Two screw conveyors are fitted in the vee bottom receiving troughs to convey crax across the perforated casings to solids discharge. Drained tallow gravitates to a single screw positioned under the twin solids screw which conveys crude tallow to the liquid discharge.