

BELL 407GX*i*

SPECIFICATIONS





Publisher's Notice

The information herein is general in nature and may vary with conditions. Individuals using this information must exercise their independent judgment in evaluating product selection and determining product appropriateness for their particular purpose and requirements. For performance data and operating limitations for any specific mission, reference must be made to the approved flight manual. Bell Textron Inc. makes no representations or warranties, either expressed or implied, including without limitation any warranties of merchantability or fitness for a particular purpose with respect to the information set forth herein or the product(s) and service(s) to which the information refers. Accordingly, Bell Textron Inc. will not be responsible for damages (of any kind or nature, including incidental, direct, indirect, or consequential damages) resulting from the use of or reliance on this information. Bell Textron Inc. reserves the right to change product designs and specifications without notice.

© 2026 Bell Textron Inc.

All registered trademarks are the property of their respective owners.



Table of Contents

Bell's Modern Long Light Single..... 1

Specification Summary (U.S. Units)..... 2

Specification Summary (Metric Units)..... 3

Helicopter Dimensions 4

Garmin G1000H® NX*i*..... 8

Enhancements included in standard Bell 407GX*i*..... 17

Additional Enhancement Options..... 18

Seating and Interiors 19

Mission Profiles..... 20

External Paint Schemes..... 22

Basic Bell 407GX*i* Configuration 23

Standard Configuration 24

Bell 407GX*i* Optional Accessories..... 25

Helicopter Performance Charts 28

Fuel Flow vs. Airspeed Charts 33

Cost of Operations 46

Component Overhaul..... 50

Global Customer Solutions 51

Industry Leading 24/7/365 Support..... 51

MyBell..... 51

CAP..... 52

Service Centers..... 54

Customer Service Facilities 55

Training..... 56

Aeronautical Accessories..... 61

Bell's Modern Long Light Single

BUILT FOR YOUR LIGHT HELICOPTER MISSION

A big part of completing any mission starts with putting together the right team. At Bell, our goal is to produce aircraft that are dependable, flexible, and can fit almost any need, which is why so many operators choose Bell 407GX_i helicopters to be part of their teams.

The reliability, speed, performance, and maneuverability of the Bell 407GX_i helicopter is integrated with a cabin configurable for a wide variety of missions and payloads. It features a spacious interior with room for up to five passengers to enjoy wide-open, club seating. Passenger comfort is enhanced with a quiet and smooth ride in virtually all weather conditions.

The Rolls Royce 250-C47E/4 turbine FADEC engine delivers exceptional hot and high performance along with a cruise speed of 133 kts (246 kph). Bell's products are backed by our renowned in-service support. The Bell 407GX_i proves you don't have to sacrifice comfort for performance.

The superior performance of the Bell 407GX_i Garmin G1000H NX_i suite provides critical flight information for crews at a glance, allowing for greater situational awareness and safety.



TAKING THE BELL 407 PRODUCT LINE EVEN FURTHER

No matter what today's mission might be, the Bell 407GX_i provides the performance, reliability and capability you need to safely accomplish it.

Federal Aviation Administration (FAA) NextGen Capability Now: The Bell 407GX_i exceeds the requirements of the FAA's NextGen air traffic management system, that all aircraft in controlled airspace must be equipped with ADS-B "Out" technology". The Bell 407GX_i is certified for ADS-B "Out" and ADS-B "In". The GTX 335R ES transponder provides the ADS-B "Out" capability required by NextGen. For more complete situational awareness that exceeds the FAA's NextGen requirements, an optional Garmin GTX 345R ES transponder is available for the Bell 407GX_i. The GTX 345R transponder gathers information about the Bell 407GX_i position, track and speed from the G1000H[®] NX_i WAAS GPS and combines it with the ADS-B "In" data for a more precise picture of what's happening in the sky. This allows for better pilot situational awareness and leads to safer air traffic separation capabilities. The GTX 345R also receives subscription-free Flight Information Service-Broadcast (FIS-B) weather broadcasts from ADS-B ground stations.

Specification Summary (U.S. Units)

WEIGHTS (LB)

Empty Weight (Base Aircraft) ^[1]	2700	Max Gross Weight with External Load	6,000
Max Internal Gross Weight (Normal / Optional ^[2])	5,000 / 5,250	Maximum External Load (Cargo Hook Limit)	3,100
Useful Load (Base Aircraft, Normal / Optional ^[2])	2,300 / 2,550		

PERFORMANCE SUMMARY ^[3] (International Standard Day except as noted)

			Takeoff Gross Weight (lb)			
			4,000	4,500	5,000	5,250 ^[2]
IGE Hovering Ceiling	ISA	ft	19,900	16,790	13,550	5,420
	ISA + 20 °C	ft	17,160	13,410	9,960	3,140
	ISA + 30 °C	ft	15,380	11,580	7,880	2,070
OGE Hovering Ceiling	ISA	ft	18,720	15,260	11,940	5,420
	ISA + 20 °C	ft	15,540	11,730	8,270	3,140
	ISA + 30 °C	ft	13,720	9,760	5,850	2,070
Service Ceiling (MCP)	ISA	ft	20,000+	20,000+	18,940	17,490
	ISA + 20 °C	ft	20,000+	19,230	16,050	14,510
	ISA + 30 °C	ft	20,000+	17,720	14,320	12,650
Maximum Cruise Speed (True Airspeed)	SL, ISA	ktas	136	135	133	132
	SL, ISA + 20 °C	ktas	138	136	134	133
	4,000 ft, ISA	ktas	141	140	136	134
	4,000 ft, ISA + 20 °C	ktas	141	138	134	131
Cruise at Long Range Cruise Speed (LRC)						
Range (Standard Fuel, No Reserve)	SL, ISA	nmi	350	344	337	332
LRC Speed (Average True Airspeed)		ktas	118	118	120	120
Range (Standard Fuel, No Reserve)	4000 ft, ISA	nmi	393	383	373	365
LRC Speed (Average True Airspeed)		ktas	118	119	120	120
Endurance at Loiter (60 kias) (Standard Fuel, No Reserve)	SL, ISA	hr	4.2	4.1	4.0	3.9
	4,000 ft, ISA	hr	4.7	4.5	4.3	4.2

ENGINE RATING

Rolls-Royce 250-C47E/4 with Full Authority Digital Electronic Control		
Takeoff Power	Uninstalled Thermodynamic Capability	862 SHP
	Mechanical Limit	674 SHP
Maximum Continuous	Uninstalled Thermodynamic Capability	761 SHP
	Mechanical Limit	630 SHP

TRANSMISSION RATING (Engine Output)

Takeoff Power (5 minutes)	674 SHP
Maximum Continuous	630 SHP

FUEL CAPACITY (Usable)

Standard	127.8 US Gallons
Auxiliary (Optional)	19.0 US Gallons

- Notes: [1] The Empty Weight (base aircraft) includes 7-place upholstered interior with individual seat belts, carpeting, and soundproofing material. Ballast is not included since it is a function of installed optional equipment. 13 pounds of oil is included.
 [2] Operation at Internal Gross Weight above 5,000 pounds requires the Optional Increased Internal Gross Weight Kit.
 [3] Refer to demonstrated takeoff and landing and maximum operating altitude notes on the performance charts.

Specification Summary (Metric Units)

WEIGHTS (KG)

Empty Weight (Base Aircraft) ^[1]	1,224	Max Gross Weight with External Load	2,722
Max Internal Gross Weight (Normal / Optional) ^[2]	2,268 / 2,381	Maximum External Load (Cargo Hook Limit)	1,406
Useful Load (Base Aircraft, Normal / Optional) ^[2]	1,043 / 1,156		

PERFORMANCE SUMMARY ^[3] (International Standard Day except as noted)

			Takeoff Gross Weight (kg)			
			1,814	2,041	2,268	2,381 ^[2]
IGE Hovering Ceiling	ISA	m	6,066	5,118	4,130	1,652
	ISA + 20 °C	m	5,230	4,087	3,036	957
	ISA + 30 °C	m	4,688	3,530	2,402	631
OGE Hovering Ceiling	ISA	m	5,706	4,651	3,639	1,652
	ISA + 20 °C	m	4,737	3,575	2,521	957
	ISA + 30 °C	m	4,182	2,975	1,783	631
Service Ceiling (MCP)	ISA	m	6,096+	6,096+	5,773	5,331
	ISA + 20 °C	m	6,096+	5,861	4,892	4,423
	ISA + 30 °C	m	6,096+	5,401	4,365	3,856
Maximum Cruise Speed (True Airspeed)	SL, ISA	km/h	252	249	246	244
	SL, ISA + 20 °C	km/h	255	253	248	246
	1,200 m, ISA	km/h	262	259	252	248
	1,200 m, ISA + 20 °C	km/h	261	256	248	243
Cruise at Long Range Cruise Speed (LRC)						
Range (Standard Fuel, No Reserve)	SL, ISA	km	649	637	624	616
LRC Speed (Average True Airspeed)		km/h	218	219	222	222
Range (Standard Fuel, No Reserve)	1,200 m, ISA	km	728	710	690	676
LRC Speed (Average True Airspeed)		km/h	218	221	222	222
Endurance at Loiter (111 km/h) (Standard Fuel, No Reserve)	SL, ISA	hr	4.2	4.1	4.0	3.9
	1,200 m, ISA	hr	4.7	4.5	4.3	4.2

ENGINE RATING

Rolls-Royce 250-C47E/4 with Full Authority Digital Electronic Control		
Takeoff Power	Uninstalled Thermodynamic Capability	643 kW
	Mechanical Limit	503 kW
Maximum Continuous	Uninstalled Thermodynamic Capability	567 kW
	Mechanical Limit	470 kW

TRANSMISSION RATING (Engine Output)

Takeoff Power (5 minutes)	503 kW
Maximum Continuous	470 kW

FUEL CAPACITY (Usable)

Standard	484 Liters
Auxiliary (Optional)	72 Liters

- Notes: [1] The Empty Weight (base aircraft) includes 7-place upholstered interior with individual seat belts, carpeting, and soundproofing material. Ballast is not included since it is a function of installed optional equipment. 5.9 kilograms of oil is included.
 [2] Operation at Internal Gross Weight above 2,268 kilograms requires the Optional Increased Internal Gross Weight Kit.
 [3] Refer to demonstrated takeoff and landing and maximum operating altitude notes on the performance charts.

Helicopter Dimensions

LOW SKID GEAR

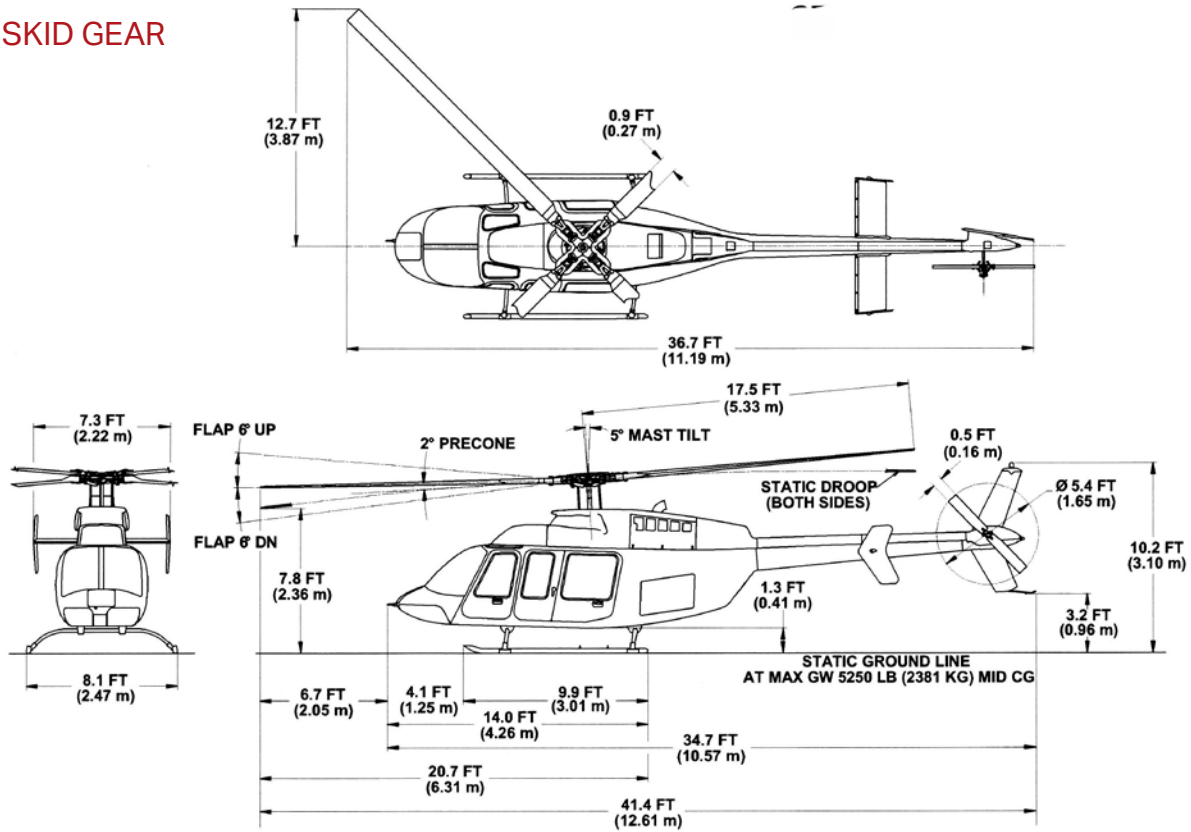

HIGH SKID GEAR WITH AA FLITESTEP®

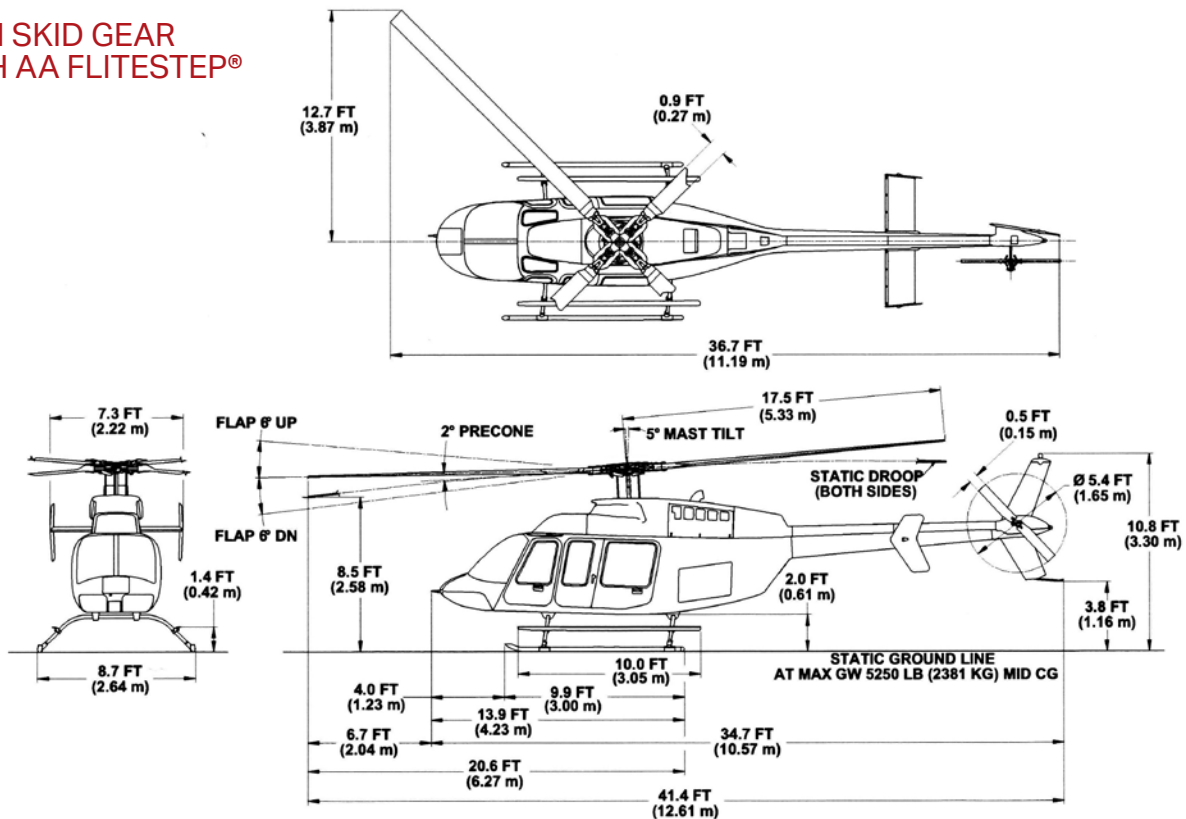

Helicopter Dimensions

OPTIONAL EMERGENCY FLOAT GEAR WITH AA FLOATSTEP™

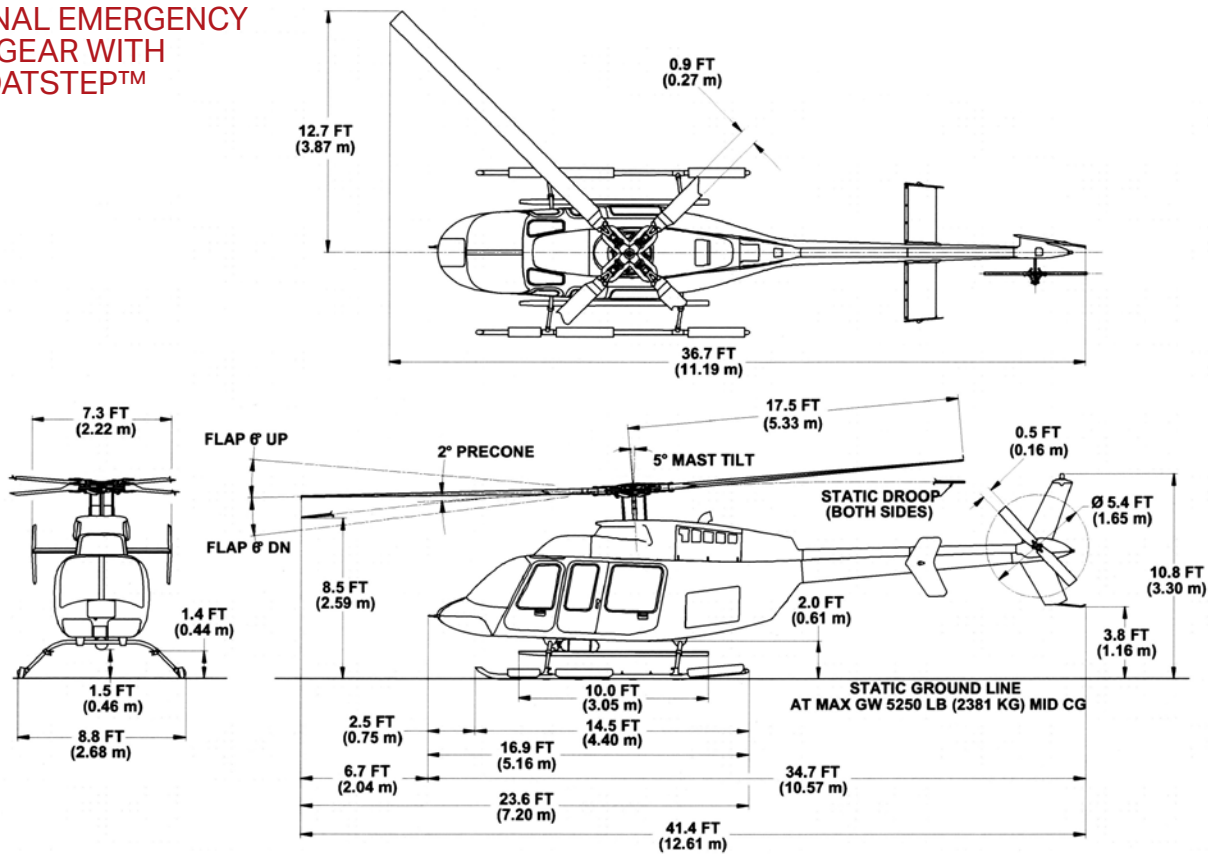

OPTIONAL BLADE FOLDING KIT DIMENSIONS

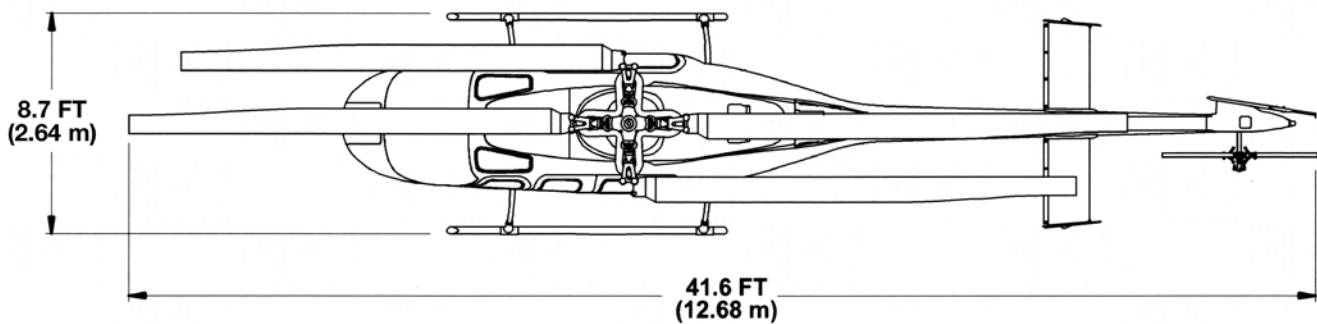

MINIMUM HANGAR SIZE

	US Units	Metric Units
Rotor not Folded	25.1 ft x 36.7 ft	7.7 m x 11.2 m
Rotor Folded (High Skid Gear)	8.7 ft x 41.6 ft	2.6 m x 12.7 m

Note: Allowance should be made for skid gear, ground wheels, empty fuel condition and door lip when considering hangar door width and height

LANDING GEAR LOADING AT MAXIMUM GROSS WEIGHT (5,000 LB/2,268 KG) - based on one "G" static conditions at most structural cg limit

HELIPAD LOADING (5,000 lb) - US UNITS

GEAR TYPE	LOADING POUNDS		CONTACT AREA SQ.IN.		CONTACT PRESSURE PSI	
	FORWARD	AFT	FORWARD	AFT	FORWARD	AFT
Standard Skid	1338	3662	16.5 x 2	16.5 x 2	41	111
High Skid	1307	3693	16.5 x 2	16.5 x 2	40	112
Emer Float Skid	1307	3693	16.5 x 2	16.5 x 2	40	112

HELIPAD LOADING (2,268 KG) - METRIC UNITS

GEAR TYPE	LOADING (KG)		CONTACT AREA (CM ²)		CONTACT PRESSURE KG/CM ²	
	FORWARD	AFT	FORWARD	AFT	FORWARD	AFT
Standard Skid	606.9	1661.1	106.5 x 2	106.5 x 2	2.9	7.8
High Skid	592.9	1675.1	106.5 x 2	106.5 x 2	2.8	7.9
Emer Float Skid	592.9	1675.1	106.5 x 2	106.5 x 2	2.8	7.9

LANDING GEAR LOADING AT MAXIMUM GROSS WEIGHT (5,250/2,381 KG) - based on one "G" static conditions at most structural cg limit

HELIPAD LOADING (5,250 LB) - US UNITS

GEAR TYPE	LOADING POUNDS		CONTACT AREA SQ.IN.		CONTACT PRESSURE PSI	
	FORWARD	AFT	FORWARD	AFT	FORWARD	AFT
Standard Skid	1405	3845	16.5 x 2	16.5 x 2	43	117
High Skid	1372	3878	16.5 x 2	16.5 x 2	42	118
Emer Float Skid	1372	3878	16.5 x 2	16.5 x 2	42	118

HELIPAD LOADING (2,381 KG) - METRIC UNITS

GEAR TYPE	LOADING (KG)		CONTACT AREA (CM ²)		CONTACT PRESSURE KG/CM ²	
	FORWARD	AFT	FORWARD	AFT	FORWARD	AFT
Standard Skid	637.3	1744.1	106.5 x 2	106.5 x 2	3.0	8.2
High Skid	622.3	1759.0	106.5 x 2	106.5 x 2	2.9	8.3
Emer Float Skid	622.3	1759.0	106.5 x 2	106.5 x 2	2.9	8.3

CABIN DIMENSIONS

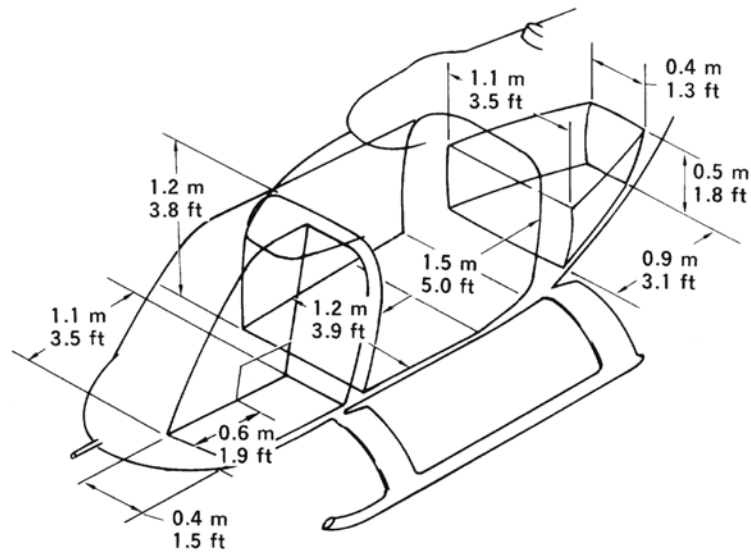

Approximate Cargo Space		
Aft cabin	85 ft ³	2.4 m ³
Left front	20 ft ³	0.6 m ³
Baggage compartment	16 ft ³	0.45 m ³
Floor Loading		
Cabin	75 lb/ft ²	366 kg/m ²
Baggage	86 lb/ft ²	420kg/m ²
Max baggage weight	250 lb	113 kg

Garmin G1000H[®] NXi

RAISING THE PROVEN PERFORMANCE AND RELIABILITY OF THE BELL 407 TO A HIGHER LEVEL

The Garmin G1000H[®] NXi Integrated Avionics System in the Bell 407GX*i* has been designed to improve situational awareness and reduce pilot workload through easy to read displays of critical flight information, tuning of communication and navigation frequencies, and simple flight planning management. The Bell 407GX*i*'s standard configuration G1000H[®] NXi includes the Synthetic Vision System (SVS) and initial installation of the HTAWS and Navigation database^[1]. The system has two SD card slots to facilitate data Input/Output tasks such as flight plan and database uploading or critical flight data downloads. The system takes advantage of the latest in display, computer processing, and digital data bus technology to provide a high degree of redundancy, reliability, and flexibility.



The Bell 407GX*i* Garmin G1000H NXi suite.

The main components of the Garmin G1000H[®] NXi Integrated Avionics system includes:

- Two 10.4" (26.4 cm) GDU 1050H high definition LCD displays (interchangeable PFD/MFD)
- Two GIA 64H Integrated Avionic Units, including:
 - GPS / WAAS Receiver
 - VHF COM Transceiver
 - VHF NAV and Glideslope Receivers
 - Aural Alert Generation
- GEA 71HB Engine and Airframe Unit (signal processing of engine parameters and major system sensors)
- GSU 75 Air Data and Attitude Heading Reference System and GMU 44 Magnetometer
- GMA 350Hc Audio System^[2]
- GTX 335R Extended Squitter (ES) Mode S Transponder

Notes: [1] Database subscription updates are the responsibility of the helicopter owner/operator.

[2] Integrated Marker Beacon Receiver capability is available with customizing of a Marker Beacon Antenna, and 3D Audio capability is available with customizing of stereo headsets.

Garmin G1000H[®] NXi



INTEGRATED GARMIN G1000H[®] NXi Suite

Feature	
Two-Display System	Twin 10.4" (26.4 cm) flat panel high definition LCDs, interchangeable for Primary Flight Display (PFD) or Multi Function display (MFD)
Flight Instruments	Integrated on PFD with stand-by airspeed, altimeter, compass
Engine Instruments	Integrated on PFD / MFD with Power Situation Indicator (PSI), Engine Indication System (EIS), fuel flow, automated power assurance check
EICAS & Audio Alerts	Engine Indicating and Crew Alerting System (EICAS) integrated on PFD / MFD. Audio alerts integrated into intercom system
COM/NAV	Dual COM / NAV / GPS, WAAS, Mode S Transponder with Extended Squitter (ES), ADS-B out, FMS, auto-tuning
Situational Awareness	Integrated on PFD / MFD, Traffic Information System (TIS), HTAWS, Synthetic Vision System, Moving Map, Fuel and NAV range, Tail Rotor Camera display on MFD, optional TAS, optional transponder with ADS-B "In" is available
Intercom	ICS with recorder / playback, cell phone and MP3 jack, Automatic Speech Recognition, Bluetooth capability

Garmin G1000H[®] NXi

DISPLAYS

The Garmin G1000H[®] NXi presents critical flight information to the pilot at a glance for greater situational awareness, simplicity and safety. The pilot can easily and quickly select the information formats to display on the interchangeable Primary Flight Display (PFD) and Multi Function Display (MFD). The Power Situation Indicator (PSI), located in the lower left-hand corner of the PFD provides a "one stop shop" for power indications and limits.

The displays accept both NTSC and PAL format composite video signals from external sources, including the Bell 407GX's standard configuration Tail Rotor Camera and optional imaging devices such as multi-sensor camera thermal imaging systems for operations.

Primary Flight Display (PFD) Typical User Selected Formats

The PFD displays all major flight parameters in an intuitive, easy to scan layout: Attitude, Airspeed, HSI, Altitude and VSI. Primary and inset screens can be user-selected to display a variety of additional functions, including "Pathways in the Sky", Flight Path Vector, Synthetic Vision, HTAWS, and Traffic Information System (TIS) ^[1].



PFD Main Screen Display



PFD Map Overlay in HSI



PFD Flight Planning Display



PFD 'Pathways in the Sky' Display

Notes: [1] The GTS 800 TAS (Traffic Advisory System) is available as an optional kit.

Garmin G1000H[®] NXi

Multi Function Display (MFD) Typical User Selected Formats

User-selectable MFD display options in the standard configuration G1000H[®] NXi Suite include System Status, checklists, flight planning, maintenance pages, engine pages, Power Assurance Screen, NAV map, Traffic Information System (TIS), engine and transmission information, fuel status, and calculated range.

Optional features include satellite weather through an XM satellite datalink^[1] (North America) or Iridium[®] [2] Voice/Data transceiver^[3] (worldwide), and the Garmin GTS 800 Traffic Advisory System.

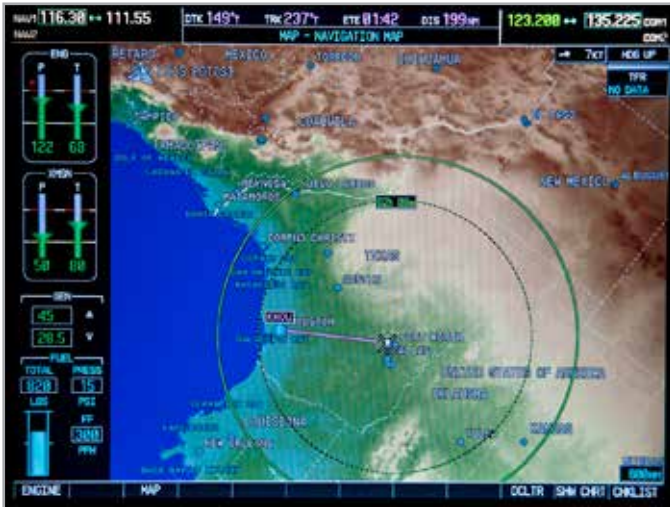

MFD Range Ring Display.



MFD Flight Planning Display.



MFD Tail Rotor Camera / Map Display.



MFD Power Assurance with HOGE performance in real time mode.

- Notes:
- [1] Subscription to XM Satellite Weather and/or Radio is the responsibility of the helicopter owner/operator.
 - [2] Iridium[®] is a registered trademark of Iridium Satellite LLC.
 - [3] Subscription to Iridium[®] Voice/Data service is the responsibility of the helicopter owner/operator.

Garmin G1000H[®] NX*i*

Power Situation Indicator (PSI)

The PSI is a single indicator section of the PFD that provides the pilot quick information about power settings. The color-coded parameter display automatically highlights normal performance (green), near limits (yellow) or exceedence (red).

COMMUNICATIONS AND NAVIGATION

Each of the standard configuration dual Garmin GIA 64H Integrated Avionics Units includes a GPS/WAAS receiver, VHF COM Transceiver and VHF NAV and Glideslope receivers. It also maintains a prioritized queue of aural alerts for Aural Alert Generation.

AUDIO SYSTEM^[1]

The GMA 350Hc Audio Control Panel incorporate Bluetooth technology for wireless access to music, phone and more. This adds to an impressive list of features including industry-first Telligent Voice Command technology, 3D audio processing and enhanced auto squelch capability and more. These features decrease heads-down time and increase overall situational awareness in the cockpit. The GMA 350Hc provides cockpit ICS, pilot and copilot volume control and dual stereo entertainment inputs. The COM interface supports up to three (3) transceivers and the NAV interface supports up to five (5) radios. The system can accommodate up to seven (7) mono/stereo headsets (two (2) for pilot/copilot and five (5) for passengers), and provides ICS audio isolation modes for the pilot, copilot and passenger headset positions.

The GMA 350Hc features two (2) entertainment inputs (MUSIC 1 and MUSIC 2), with identical streaming content from the optional GDL 69H XM Radio Datalink^[2]. A 3.5 mm front panel mini-jack on the GMA 350Hc can be used as an entertainment input or as a telephone input when the optional GSR 56H Iridium[®] Voice/Data Transceiver^[3] is installed.

EXTENDED SQUITTER (ES) MODE S TRANSPONDER

The GTX 335R Extended Squitter (ES) Mode S Transponder functions are controlled by the PFD display, and support European Mode S mandates for Extended Squitter, Elementary Surveillance and Enhanced Surveillance. In addition, the GTX 335R ES provides Automatic Dependent Surveillance-Broadcast (ADS-B) "Out" capability. With ADS-B "Out" capability, position velocity and heading information are automatically transmitted to other aircraft and ground stations to improve situational awareness and flight safety.



Power Situation Indicator.

- Notes:
- [1] Integrated Marker Beacon Receiver capability is available for the GMA 350H by installing a marker beacon antenna.
 - [2] Subscription to XM Satellite Weather and/or Radio is the responsibility of the helicopter owner/operator.
 - [3] Subscription to Iridium[®] Voice/Data service is the responsibility of the helicopter owner/operator.

Garmin G1000H[®] NX_i

GARMIN SOFTWARE FEATURES

The Weight and Balance Multi-Function Display (MFD) page provides information about the helicopter weight and center of gravity. It uses pilot data entry for the crew, passengers, baggage loads, helicopter empty weight and the fuel load. It can synchronize with fuel quantity indication instead of relying on manual entry. Longitudinal and lateral aircraft CG are automatically calculated and displayed graphically with a digital readout. The Longitudinal CG slider indicator includes a cyan bar to show CG migration due to fuel burn.

The Hover Performance page presents the pilot with real-time or pre-flight planning power required to perform OGE or IGE hover operations when OAT and altitude are in the certified envelope. The page consists of a Hover Power Indicator (HPI) and the Hover Performance Display section.

The HPI indicator displays power required to hover OGE or IGE at the current aircraft weight, OAT, pressure altitude, and wind condition. The PSI displays predicted power required to hover OGE or IGE at the pilot's entered destination aircraft weight, OAT, pressure altitude, and wind condition. This improves hot/high operations by letting pilots know ahead of time if they can take-off at a hot/high landing site.

In real time operation, the avionics system function displays the HPI indicator based on the largest hover power margin condition between the installed engine hover performances, all these being in terms of Q-HOV, MGT-HOV or NG-HOV. This indication aids pilots with respect to the appropriate engine setting. The automated tool, represented by the power performance check, helps further reduce pilot workload.

In hover predictive mode, the parameters in the Hover Performance Display section can be manually adjusted and are displayed in cyan. The HPI is also displayed in cyan. The avionics system displays the MAX INTERNAL HOV WT and MAX EXTERNAL HOV WT, information which is suppressed in real time. This hover performance prediction function allows the internal/external hover weight predictions based on the Pilot adjustable parameters or additional inputs; e.g. anti-ice aircraft kits configuration, pressure altitude, OAT, wind speed, engine margin (i.e. this is a pilot input, which represents the average of the last ten power assurances checks), generator load, and hook weight.



Weight and Balance CG Display Page.



Weight and Balance Data Entry Page.



Pre-flight planning hover performance check (HOV-Predictive Mode).

Garmin G1000H[®] NX_i

The impending exceedance alert tone provides an aural alert to the pilot before encountering an engine exceedance. The aural alert tone is generated when any of the engine parameters are operating in a time-limited range. This capability especially benefits Bell 407GX_i missions where it is common practice for the pilot to operate the aircraft at high power settings while also looking outside the aircraft. Profile and Path views are selectable and displayed on the Navigation Map MFD page. When the Profile View is enabled, it is displayed in a window below the Navigation Map. Altitude is shown along a vertical scale, with an aircraft icon positioned at the current altitude. Distance is represented horizontally along the bottom of the Profile View, and increases from left (present position) to right.

The Profile View is based on the current aircraft track (or heading if track is unavailable) and shows the highest known terrain or obstacles within a predetermined width from the present aircraft position to the end of the profile range.

The Profile Path displays the horizontal and lateral boundaries of the Profile View. The path is shown as a white rectangle on the Navigation Map Page and is only available when Profile View is enabled. White range markers both edges of the Profile Path rectangle match the range markers along the distance scale inside the Profile View display whenever the profile range is at least 4 nm.

for Bell 407 aircraft. It features greater capabilities at a lower cost and is the only kit that is fully-integrated with the Garmin G1000H[®] NX_i avionics suite to display autopilot modes, hold references, audio alerts and CAS messages. These kits provide enhanced lateral, longitudinal, and yaw stability in low- speed flight and a cyclic force trim release switch, a beep reference switch, pitch/roll hands-on stability augmentation, and pilot-initiated automatic recovery.



Real-time hover performance check.

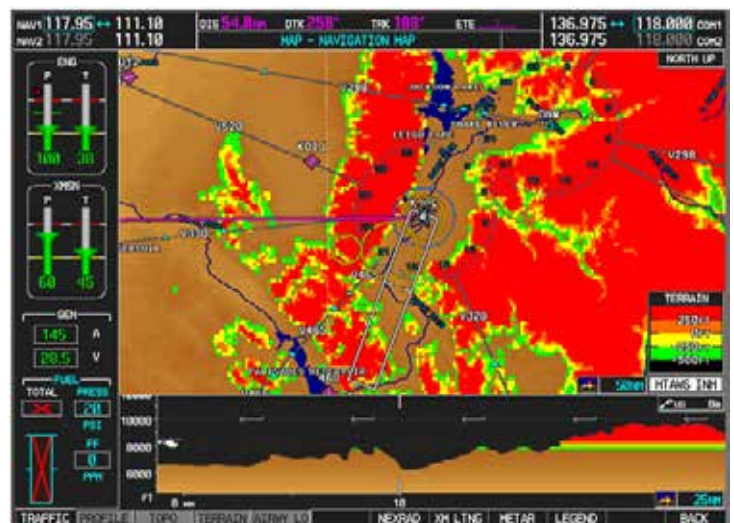

Profile Path.

OPTIONAL EQUIPMENT ENHANCEMENTS

The following optional kits are available to further enhance the capabilities of the Bell 407GX_i helicopter's Integrated Avionics System.

GDL 69AH XM Weather Radio Datalink

A remote-mounted XM satellite radio receiver capable of receiving digital datalink weather and digital audio entertainment from an XM satellite. XM Weather and Radio operate in the S-band frequency range to provide continuous uplink capabilities at any altitude throughout North America. An individual 3rd party XM / WX subscription is required to receive XM / WX data signals. Subscriptions are available for either weather or digital audio entertainment services separately or for both services.

Garmin G1000H[®] NX_i

GDL 59H Datalink Management Unit

Provides a flight parameter recorder function and a high speed data link between the aircraft systems and ground computers using 802.11 g ("Wi-Fi") while the aircraft is on the ground, and a required interface to the optional GSR 56H Iridium[®] Voice/Data Transceiver.

GSR 56H IRIDIUM[®] Voice/Data Transceiver

Provides low speed data transmission via the Iridium[®] satellite network supporting both Iridium[®] RUDICS (Internet) or Iridium[®] Short Burst data formats, fully integrated satellite phone functionality which can be dialed through the MFD, SMS Text Messaging, and Worldwide Weather capability. Subscription to Iridium[®] Voice / Data service is the responsibility of the helicopter owner / operator.

GTS 800 TAS (Traffic Advisory System)

Provides expanded traffic alerts through both active and passive surveillance capabilities, and the ability to process 1090 MHz ADS-B extended squitter from other aircraft. When installed, the optional GTS 800 TAS System replaces the standard configuration TIS (Traffic Information System), using active interrogation of Mode S and Mode C transponders to provide Traffic Advisories to the pilot independent of the air traffic control system.

GRA 55 Radar Altimeter (Including 5G Filter)

Provides a smooth and consistent readout of your altitude Above Ground Level (AGL) utilizing the same technology as the GRA 5500. The GRA 55 is designed to work in a multitude of environments, allowing you to go from rough terrain to tree canopies, to sand, to choppy water and know exactly how much altitude you have to maneuver. Includes a remote external filter to meet FAA/TCCA airworthiness directives, ensuring safety and compliance by mitigating 5G interference.

GTX 345R Transponder

The Garmin GTX 345R Transponder (ADS-B In & Out) Capability replaces the basic ship GTX 335R.

BELL 407GX_i Autopilot Kit

The Bell 407GX_i autopilot Stability and Control Augmentation System (SCAS) significantly reduces pilot workload by providing precise control during all modes of flight, regardless of wind conditions or the aircraft's center of gravity. It also features a recovery mode which allows the aircraft to safely exit inadvertent IMC or unusual attitudes if a pilot loses visual reference due to limited visibility conditions. Upon initiating the autopilot "Go Around" mode using the collective or mode panel switch, the Bell 407GX_i autopilot system will level the pitch and roll attitude of the aircraft. The pilot can then apply power using the collective for a wings-level climb at best climb rate airspeed (70 KIAS) to safely navigate through the appropriate emergency or initiate a go-around procedure.



The Bell 407GX_i Garmin G1000H NX_i suite.

Garmin G1000H[®] NX_i

The 2-axis and 3-axis autopilot kits are a Bell 407GX_i alternative to other third-party autopilots currently on the market.

The modes and annunciations of the Bell 407GX_i autopilot include:

- Autopilot (AP) Modes
 - Attitude hold
 - Heading hold
- Coupled AP Pitch Axis Modes
 - Altitude hold
 - Altitude preselect
 - Airspeed hold
 - Glideslope capture and track (with Radar Altimeter installed)
- Coupled AP Roll Axis Modes
 - Heading select
 - FMS flight plan following
 - VOR capture and track (with Radar Altimeter installed)
 - Localizer capture and track
- PFD Annunciations
 - Pitch/Roll mode indications
 - Beep/Hold references
 - Out-of-Detent indications
 - AFCS-related CAS messages

Flight Stream 510

Wireless cockpit connectivity unlocks more capabilities from within the G1000 NX_i suite. Available as an option, Flight Stream 510 enables Database Concierge, the wireless transfer of aviation databases from the Garmin Pilot™ app on a mobile device to the G1000 NX_i system. Flight Stream 510 also supports two-way flight plan transfer, the sharing of traffic, weather, GPS information, back-up attitude information and more, between the G1000 NX_i suite and compatible mobile devices running Garmin Pilot or ForeFlight mobile.

- 1090 MHz ADS-B “Out” enables aircraft to operate at any altitude, in airspace around the globe
- Combines Mode S Extended Squitter (ES) transponder and optional WAAS/GPS position source in a single unit
- Provides access to dual-link ADS-B “In” traffic and subscription-free weather on compatible displays
- Wirelessly stream weather, traffic, GPS position and backup attitude via Connex link to Garmin Pilot and ForeFlight Mobile apps as well as the aera 795/796 Garmin portables
- Compatible with a variety of Garmin cockpit displays including G1000 and GTM 750/650 series which offer transponder code entry and control



Wireless Cockpit Connectivity
with Flight Stream 510

Search and Rescue (SAR) charts

The Garmin G1000H[®] NX_i software includes Search and Rescue (SAR) charts. The Search and Rescue feature has four basic search patterns (Parallel Track, Sector, Expanding Square and Circular) to provide air crews with step by step tracking procedures for search and rescue missions.

Normal SAR patterns are accessible via one unlock card. Enhanced SAR charts, featuring circular SAR patterns, are accessible via a second unlock card. All patterns have adjustable parameters. The most effective pattern may be chosen based on available information about the search object, the weather and the terrain. Typical flight planning parameters, such as time, speed, distance and fuel remaining, are given throughout the search mission on the flight plan pages.

Enhancements included in standard Bell 407GX_i

PRECISE FLIGHT PULSELIGHT®

The Precise Flight Pulselite® system is included as standard equipment on all new Bell 407GX_i. When enabled, the Pulselite® system alternately pulses the landing and taxi lights to enhance the visibility of the aircraft to traffic and birds. It can also be linked to automatically respond to a Traffic Collision Avoidance System (TCAS) input. According to the manufacturer, the Pulselite® system has a direct impact on reducing the number of bird strikes. The system is also available as an aftermarket installation.

HOT AND HIGH OPERATIONS

Bell customers require more from their aircraft and the Bell 407GX_i delivers. The upgraded Rolls-Royce M250-C47E/4 engine in the Bell 407GX_i provides more power at hot & high conditions. This provides for significantly more external payload at altitude or a higher hover ceiling for the same gross weight. For example, at 6,000 ft, ISA +20°C the Bell 407GX_i provides 325 lb more payload for external load operations.

With the approval of BTI-407-FMS-12, Hot and High Operations, fleeted Bell 407s equipped with R250 engines with sufficient power margins, may also take advantage of the performance increase. No additional equipment is required for installation.

As shown in the charts below, the capability gained with the Hot and High performance allows for significantly more payload at altitude. Additionally, operators flying at a given gross weight can now hover higher than before.

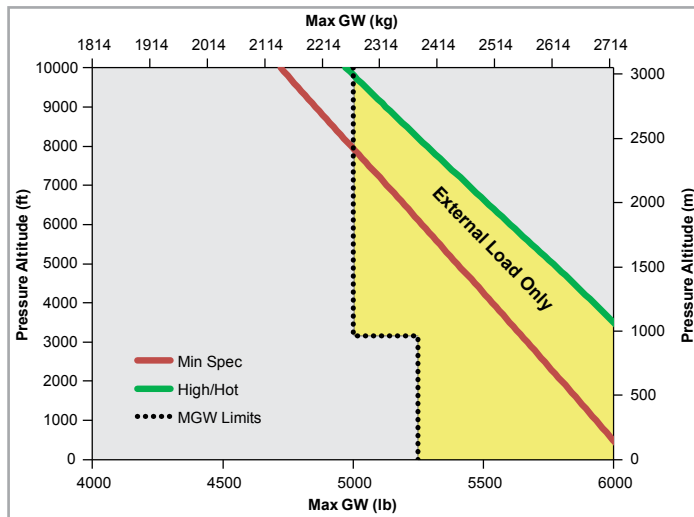

Hover In Ground Effect (HIGE)

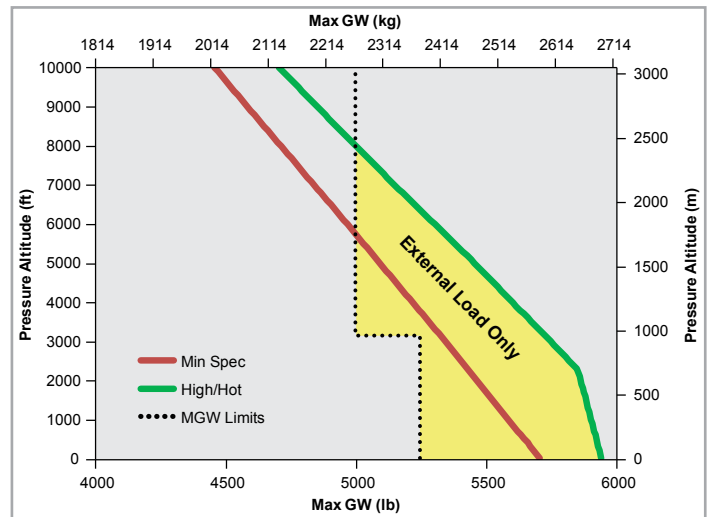

Hover Out of Ground Effect (HOGE)

Additional Enhancement Options

SINGLE PILOT INSTRUMENT FLIGHT RULES (IFR) STC KIT

An excellent solution to navigate the skies and safely complete critical missions despite low cloud ceilings. With this single-engine IFR certified aircraft, owners/operators can now maximize their uptime and accept more flights knowing that they will be completed safely. For pilots on search and rescue or medical first responder teams, don't let low visibility keep you from answering your calls. The Bell 407GX_i Single Pilot IFR Kit received its STC certification from the FAA in August, 2019 and is applicable to all FAA registered 407GX_i's. When any pilot flies under IFR, he is required to be under the direction of ATC (Air Traffic Control). They direct you regarding the aircraft direction course, speed, altitude, etc. IFR is imperative in weather with visibility lesser than 2 miles. The Bell 407GX_i is the most cost efficient IFR Platform in the market.



FORESIGHT MX HEALTH AND USAGE MONITORING SYSTEM (HUMS) (AERONAUTICAL ACCESSORIES)

The Foresight MX 407 Health and Usage Monitoring System (HUMS) utilizes next generation technology to provide enhanced visibility into your Bell 407GX_i helicopter. This saves time, cost and offers improved safety and reliability at a low cost and is lightweight at only 8.8 lbs. The system provides flight data, mechanical diagnostics, monitors exceedances and offers maintenance predictability by monitoring engine performance and vibration of critical components so you get early warning of potential maintenance problems. In addition, the system also streamlines the Rotor Track and Balance (RTB) maintenance process. Through a required subscription, operators receive text message and email notifications regarding the status of their 407, and a single model or entire fleet can be monitored in one clean dashboard that is simple to use and provides a color-coded diagnosis of the 407's condition.

POLYCARBONATE WINDSHIELD

A polycarbonate windshield offers enhanced bird strike resistance compared to the standard acrylic windshield and is available as a customizing option on all new Bell 407GX_i aircraft as well as a replacement for fielded aircraft.

AIRFRAME FUEL FILTER

A fuel filter option is now available for the 407GX_i 250-C47E/4 engine that removes the need for anti-icing fuel additives when conducting cold weather operations.

Seating and Interiors

CREW SEATING

Two individual, ergonomically designed seats, with adjustable lumbar support, each equipped with seat belt, double strap shoulder harness and inertia reel, are located in the cockpit. The color and upholstery material for the seats and interior trim of the cockpit match that which is selected for the cabin.

STANDARD SEATING AND INTERIOR TRIM

The standard cabin seating consists of five, ergonomically designed seats with individual seat belts and single strap shoulder harness, arranged with three equal width, forward facing seats across the rear of the cabin and two individual, rearward facing seats aft of the cockpit. Seats are available in fabric or vinyl with black, gray, tan or blue color options and are paired with black seat belts. The standard interior trim consists of full plastic closeouts on all airframe areas, leather covered arm rests, and molded plastic outboard headliners. The floor is covered in color coordinated low loop blend carpet or optional Aermat vinyl. The standard seating and interior trim are included in the basic aircraft weight.

CORPORATE SEATING AND INTERIOR TRIM

The corporate cabin seating consists of five 'overstuffed style' seats with individual seat belts and single strap shoulder harnesses, arranged with two extra wide forward facing outboard seats and a middle seat for occasional use across the rear of the cabin (with a fold down arm rest between the outboard seats) and two individual rearward facing seats aft of the cockpit. The corporate seats are available in a variety of Volo leather color options with color coordinated seat belts. The corporate interior trim consists of full plastic closeouts on all airframe areas, along with color coordinated Volo leather headliner inserts and armrests. The flooring is 100% wool cut pile carpet. Selection of the corporate interior trim also specifies installation of soundproofing, which provides a reduced interior noise level. The corporate seating and interior trim (and corporate soundproofing) increase the basic aircraft empty weight 21 lb (9 kg).

DESIGNER SERIES SEATING AND INTERIOR TRIM

The Designer Series interior is Bell's bespoke VIP offering, featuring black trim throughout the aircraft, complemented by black Kydex panels, including the headliner. Interior door jambs and seams are painted in matching black for a seamless, coordinated finish. This premium interior is available in five bespoke color schemes: Arctic Grey/Charcoal, Charcoal/Jet Black, Crimson/Jet Black, Sand/Jet Black, and Snow/Jet Black.

The seats are upholstered in upgraded Forte leather with custom stitching, a Bell logo, and color coordinated restraints. The Designer Series package includes enhanced cockpit storage, leather wrapped center map storage, automatic door openers for crew, cabin, and baggage compartments, color coordinated crew assist handles, USB A/C connections, ICS jacks, and a corporate soundproofing kit. Optional chrome plated vents and cup holders round out this VIP interior.



Standard Seating and Interior Trim.

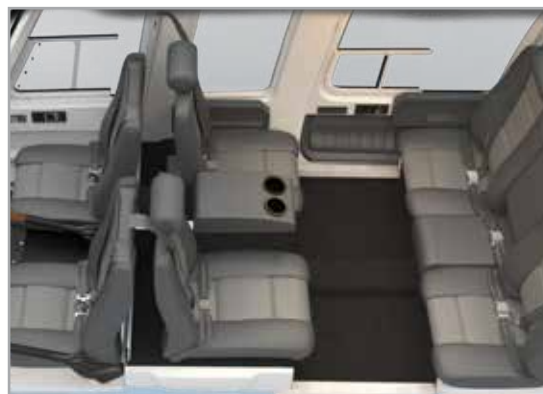

Corporate Seating and Interior Trim.



Designer Series Seating and Interior Trim

Mission Profiles

CORPORATE

This high performance single-engine helicopter provides comfortable seating for seven occupants with an available Quiet Cruise™ kit for decreased cabin noise. The Bell 407GX_i's spacious 85 ft³ (2.4 m³) cabin accommodates five passengers. It's all composite, four-blade rotor provides superior hover performance, speed and a smooth quiet ride. The dual digital FADEC (Full Authority Digital Engine Control) fuel management system of the Rolls-Royce 250-C47E/4 turbine engine enhances safety and reduced operating costs. The Bell 407GX_i is supported by Bell's globally acclaimed Customer Support and Services.



MEDICAL

Helicopter emergency medical services is demanding. The Bell 407GX_i is the ideal helicopter for HEMS operations. It strikes the perfect balance between performance, reliability and mission flexibility. A smooth ride is essential to the mission and the Bell 407GX_i delivers due to the all-composite, four-bladed rotor system that also provides excellent hover performance and speed. The Bell 407GX_i is ideal for extreme environments: high altitudes, arctic conditions or even the hottest locals. Quick and easy patient loading and unloading is provided by a standard bi-fold door with a 61-inch (155 cm) opening. Safety features include a rupture resistant fuel system, engine exceedence monitoring and a collective-mounted throttle that keeps power at the pilot's fingertips.



Mission Profiles

GENERAL/UTILITY

A high performance helicopter known for its reliability, the Bell 407GX_i offers single-engine operators proven technology combined with Bell's globally acclaimed customer support. The helicopter's spacious 85 ft³ (2.4 m³) cabin accommodating five passengers in club seating and high useful load makes the Bell 407GX_i a workhorse for utility operators. Superb overall performance is delivered by an 862 SHP FADEC-controlled Rolls-Royce 250-C47E/4 turbine engine. The all composite, four-blade rotor provides superior hover performance, speed and a smooth, quiet ride. Safety features include a rupture resistant fuel system, engine exceedence monitoring and a collective-mounted throttle that keeps power at the pilot's fingertips. The Bell 407GX_i delivers value to utility operators every day.



PUBLIC SAFETY

You protect, we serve. The Bell 407GX_i is a high-tech, single-engine helicopter with an airframe that has a track record of performance and reliability, not to mention tangible cost benefits for your organization. Its all-composite, four-blade rotor provides superior hover performance, speed and a smooth quiet ride. Safety features include a rupture resistant fuel system, engine exceedence monitoring and a collective-mounted throttle that keeps power at the pilot's fingertips. The Bell 407GX_i's spacious 85 ft³ (2.4 m³) cabin is configurable for many different missions and has an abundant capacity for law enforcement equipment (multi-sensor camera, searchlight, etc) with nearly 4-hours of loitering capabilities for surveillance missions.



External Paint Schemes



For more color options, please visit BellFlight.com or speak with a Sales Representative.

- Notes:
1. Color renderings (original) must be provided for any deviation to the standard schemes (all models).
 2. Custom paint schemes to customer specification are available, and a price quote will be provided on request. Please provide as much detail as possible when describing special instructions and custom paint schemes.
 3. The danger arrow is always applied on the tail boom between the horizontal stabilizer and the tail rotor, notwithstanding any other illustrations.
 4. Unless clearly specified (location, dimension, color), registration markings will be applied per FAA regulations (all models).
 6. Placement of Bell model logos is effected by individual paint schemes, and will be applied at the discretion of Bell unless otherwise specified by the customer.

Basic Bell 407GX_i Configuration

AIRFRAME

Cabin; bonded aluminum honeycomb, and semimonocoque structure with composite side panels and aft fuselage skins

Doors (five), one hinged double door and copilot door on left side, pilot and passengers on right side, all doors are composite material

Landing gear, tubular skid type with replaceable skid shoes

Locks for cabin doors and luggage compartment

Luggage compartment with composite door

Provisions for mooring, jacking and single point lifting

Tail boom, monocoque structure with vertical fin and fixed stabilizer

Tail skid (tail rotor guard)

Windows (except windshield), gray tinted plexiglass

Three color exterior paint schemes

INTEGRATED AVIONICS SYSTEM with GARMIN G1000H[®] NX_i SUITE

Two 10.4" high definition display units, providing Primary Flight Display (PFD) and Multi-Function Display (MFD) functionalities

Two Integrated Avionics Units, each consisting of a 16-watt VHF communication transceiver with 8.33 kHz spacing, VHF navigation, WAAS GPS navigation, and glideslope receiver

One audio control panel with clearance recording and Automatic Speech Recognition (ASR) capability

One digital Air Data Computer (ADC) with Outside Air Temperature (OAT) probe

One Air Data and Attitude Heading Reference System (ADAHRS) and magnetometer

One mode S transponder with extended squitter, including Traffic Information Service (TIS), with ADS-B "Out" capability

One engine and airframe interface unit

One engine signal conditioner

Tail rotor video camera system with capability to view approximately 25 feet in complete darkness

Synthetic Vision System (SVS), and Helicopter Terrain Awareness and Warning System (HTAWS) features

INTEGRATED AVIONICS SYSTEM with GARMIN G1000H[®] NX_i SUITE (continued)

Integrated Engine Indication and Crew Alerting System (EICAS), including Power Situation Indicator (PSI) that provides an integrated display presentation of all critical engine parameters into a single indicator to present the power "margin" remaining

Fuel flow indication with range ring display capability

Flight Data Recording of 60 standard aircraft and engine parameters and 40 customer selectable parameters

ELECTRICAL

28 volt DC system

Battery, 17 amp-hour nickel cadmium

External power and grounding receptacle

Starter-generator (180 ampere)

Solid state voltage regulator

28 volt outlet in cockpit

Heated pitot tube and Static ports

LED lighting:

Anticollision strobe

Cockpit / map

Instrument

Landing

Position

INTERIOR

7-place interior with soundproofing, carpeting, and data case. Color options available for upholstery and carpet

7-place shoulder harnesses, dual straps in cockpit, single strap in cabin

Fire extinguisher, cabin

First aid kit

Parcel shelf (behind aft seat)

Ram air ventilation system

Storage area behind pilot and copilot seats

Two David Clark headsets

Basic Bell 407GX_i Configuration

LOOSE EQUIPMENT (not included in empty weight)

Covers, engine inlet and exhaust stack
Cover pitot tube
Flight bag
Ground handling wheels with lift tube
Operating manuals: Rotorcraft flight manual Aircraft log book Engine log book
Aircraft maintenance manuals are available on ePubs located here: mybell.com
Tie-down assemblies, main rotor and tail rotor

POWERPLANT

Rolls-Royce Model 250-C47E/4 turboshaft engine with dual digital FADEC.
Fuel pump, engine driven
Fuel pumps (4 canister type) with 2 boost pumps submerged in main tank, and 2 transfer pumps in the forward fuel tanks
Crashworthy Fuel System
Oil system with sight glass
Compressor wash provisions
Engine mounted 3-micron oil filter

ROTORS AND CONTROLS

Main rotor, soft in plane flex beam hub with four fiberglass blades
Tail rotor; two fiberglass blades, semirigid
Hydraulic boost system for Main and Tail Rotor (separate pump and reservoir)
Mechanical flight control linkages throughout
Airspeed Activated Pedal Stop (AAPS) with built in test function, electrical override release switch, and manual override release

TRANSMISSION DRIVE SYSTEM

Soft mounted pylon isolation system
Freewheeling unit (between engine and main transmission)
Kaflex input drive shaft
Gearbox, tail rotor, 90° reduction
Main transmission
Oil cooler
Oil filter with replaceable type cartridge
Oil pump, constant pressure

BASIC BELL 407GX_i CONFIGURATION EMPTY WEIGHT

	lb	kg
Additional kits for basic configuration	2,700	1,225

Standard Configuration

ADDITIONAL KITS

Jettisonable doors (crew only)	Auxiliary fuel tank provisions	Dual controls
Wire Strike Protection System	High skid gear (including AA Flitestep®)	Rotor brake
28 Amp-hour Sealed Lead Acid (SLA) battery (replaces 17 amp battery)	High visibility main rotor blades	Sliding windows
Rubber Mounted Chin Bubbles	Pulse Light	

STANDARD CONFIGURATION EMPTY WEIGHT

	lb	kg
Additional kits for standard configuration	2,802	1,271

Bell 407GX_i Optional Accessories

Refer to notes for kit compatibility. Additional kits and STC items may be available for factory installation. Please consult sales or contract personnel regarding special needs prior to selection of final configuration.

OPTIONAL ACCESSORIES

Kit Description	Weight		Notes
	lb	kg	
AIRFRAME			
5,250 lb Max. Gross Weight	0	0	
Aerodynamic Hub Cover and Mounts (without Hub Frahm)	7.5	3.4	
Air Conditioner with Dual Forward Evaporators (Air Comm)	105.6	47.9	1, STC
Auxiliary Fuel Tank Equipment (19 USG / 72 L)	30.4	13.8	
Baggage Floor Protector (AA)	4.5	2	STC
Bleed Air Heater with Windshield and Chin Bubble Defrost (Air Comm)	26.0	11.8	2, STC
Cargo Mirror Kit (AA)	2.0	0.9	STC
Cockpit/Cabin Floor Protector Kit (AA)	8.5	3.9	STC
Door Openers - Automatic - Baggage Door (AA)	0.9	0.4	STC
Door Openers - Automatic - Cabin Doors (AA)	1.2	0.5	STC
Door Openers - Automatic - Crew Doors (AA)	2.8	1.3	STC
Sliding Passenger Door Kit - LH (AA)	10.5	4.8	3, STC
Sliding Passenger Door Kit - RH (AA)	10.5	4.8	3, STC
Emergency Floats Landing Gear Only (including Floatstep™)	84.5	38.3	4, 5, 6
Emergency Floats Reservoir	68.7	31.2	7
Flotation Equipment with Landing Gear (including Floatstep™)	173.2	78.6	4, 5, 6, 7
Foreign Certification - Russia (C.I.S) or China or Japan or Arabic or Mexico or Brazil or Argentina	0.1	0	
Hub Frahm (includes Hub Cover)	52.2	23.7	
Locking Fuel Cap (AA)	0.1	0	STC
Low Skid Gear	-32.1	-14.5	
Rappelling Fixture Kit LH & RH (AA)	7.0	3.2	STC
Rescue Hoist - 300 lb Capacity (Breeze Eastern/AA)	58.4	26.5	8, STC
Skid Gear Fairings - Low Skid Only	11.7	5.3	
WINDOWS			
Polycarbonate Windshields (AA)	20.4	9.3	STC
AVIONICS			
Aft Cabin ICS - 5 Place (includes David Clark Headsets)	8.4	3.8	
Cargo Hook release on Co-pilot AFCS Controls	0	0	15
Co-pilot AFCS Controls - 2 Axis	0.7	0.3	16
Co-pilot AFCS Controls - 3 Axis	0.7	0.3	16
ICS – 7 Place - Bose LEMO jacks (No Headsets included)	3.0	1.4	
ICS – Cabin Call -w- LED Light	0.2	0.1	
Artex C406-NHM ELT with PGM Adaptor	6.2	2.8	
Autopilot - 2-Axis AFCS	27.6	12.5	

Bell 407GX_i Optional Accessories

OPTIONAL ACCESSORIES

Kit Description	Weight		Notes
	lb	kg	
AVIONICS (CONTINUED)			
Autopilot - Addition of 3rd Axis	9.0	4.1	14
Garmin GDL 69AH XM Weather with Audio	4.4	2	
Garmin GTS 800 TAS	20.7	9.4	9
Garmin Flight Stream 510	0	0	
Garmin Transponder GTX 345R	0	0	
Marker Beacon (Garmin GMA 350H Audio Panel)	0.6	0.3	13
Mid-Continent Standby Attitude Module (SAM) (AA)	1.8	0.8	STC
Search Patterns (displayed on G1000H NXI)	0	0	
Radar Altimeter - GRA 55 with 5G Filter	9.9	4.5	9
EQUIPMENT			
Cargo Hook Equipment	8.9	4	17
Cargo Hook Provisions	5.3	2.4	
Cargo Restraint Internal Provisions	1.9	0.9	
Cockpit Storage Kit	1.4	0.6	
Litter Equipment (One)	-13.3	-6.0	10
Litter Provisions	5.7	2.6	
Litter Ski Provisions	1.5	0.7	10
Main Rotor Blade Expandable Bolts (2)	1.5	0.7	4
Main Rotor Blade Folding Kit with 2 Expandable Bolts (Paravion)	0.5	0.2	11, STC
Non-Halon Cockpit Fire Extinguisher	3.5	1.6	
Snow Baffles	5.2	2.4	
INTERIOR			
Armrests - Corporate	0.3	0.1	4, 12
Headliner - Standard with AC Ducting	4.7	2.1	4
Interior Trim - Corporate	7.3	3.3	4, 12
Designer Series Interior Trim (Black): Interior Black Panels (including Headliner), Paint Exposed Interior Airframe 37038 Camo Black & Black Instrument Panel	7.3	3.3	12
Passenger and Crew Seats - Corporate	0.9	0.4	4
Soundproofing - Corporate	8.2	3.7	4, 12
Spacemaker and Cover (AA)	6	2.7	STC
4-point Restraint system (Crew & Passengers)	8.7	3.9	
POWERPLANT			
Airframe Fuel Filter	6.2	2.8	
Engine Fire Detector	2.0	0.9	
Increased Starter Generator	1.0	0.5	
Inducer Vent Filter (AA)	2.8	1.3	STC
Inlet Barrier Filter with Access Door (AA)	12.2	5.5	STC
Particle Separator with Engine Bleed Air Network	16.9	7.7	2, 4
Quiet Cruise	0.2	0.1	

Bell 407GX_i Optional Accessories

OPTIONAL ACCESSORIES

Kit Description	Weight		Notes
	lb	kg	
OTHER			
No Ground Handling Wheels	0	0	4
Paint - No Exterior Paint	-16.7	-7.6	
Paint - White Paint Only	0	0	
GPMS Foresight MX HUMS	8.8	4	STC
Single Pilot IFR (FAA STC – Other counties validation pending)	56.3	25.5	13, STC
Lightweight FDR Hensoldt LCR-100 (Bell Prague)	TBD	TBD	STC

EXPLANATORY NOTES

All equipment kits require Provision Kits prior to installation.

Notes: For commonality, notes shown below are identical in Product Specification and Price List.

- Requires Headliner - Standard with AC Ducting.
- Particle separator and Bleed Air Heaters both include Bleed Air Network. If both kits are installed subtract 3.8 lb (1.7 kg).
- Sliding Passenger door(s) require sliding door armrest(s) which subtracts 1.9 lb (0.9 kg) per door.
- Price and/or Weight includes credit for basic ship hardware removed.
- Kit includes Floatstep™ (STC # 407-303-003) (29 lb [13 kg]).
- The High Skid Gear (including AA Flitestep®) included in the Standard Configuration Empty Weight, is not required when a Float Landing Gear is installed, therefore remove 32.1 lb (14.6 kg) from Standard Configuration Empty Weight.
- A Complete Emergency Flotation System requires Flotation Equipment with Landing Gear (including Floatstep™) and Emergency Float Reservoir.
- Weight assumes the L/H Flitestep® is removed (14.5 lb [6.6 kg])
- Avionic Shelf Kit must be installed prior to or concurrently with the installation of this kit.
- Requires installation of Litter provisions. Delta weight of this Litter Equipment shown includes removing the Copilot's Seat, L/H Aft-facing, L/H Forward-facing, and Center Forward-facing Passenger Seats.
- Weight is for provisions only.
- Corporate or Designer Series interiors require corporate soundproofing and corporate armrests.
- Single Pilot IFR Kit (STC) requires the Autopilot - 3-Axis AFCS kit and 28 Amp-hour Sealed Lead Acid (SLA) Battery installed. If operating under PART 135 requires a Marker Beacon installed.
- Autopilot - 3-Axis AFCS requires the Mid-Continent MD-302 Standby Attitude Module (AA), Radar Altimeter - GRA 55, Autopilot - 2-Axis AFCS.
- Either Co-pilot AFCS Controls kit (2 or 3 axis) and the Cargo Hook provisions must be installed prior to or concurrently with Cargo Hook release on Co-pilot AFCS Controls kit.
- 2 or 3 Axis Autopilot must be installed prior to or concurrently with either Co-pilot AFCS Controls kits (2 or 3 axis).
- Requires provision kit installed prior to or concurrently with equipment.

STC KITS

Select Supplemental Type Certificated Optional Equipment Kits are available for installation at the Bell Textron Inc. factory. Please contact your Bell sales representative for availability and pricing information.

Helicopter Performance Charts

IGE and OGE hover, and service ceiling performance chart data based on the following:

- Rolls-Royce 250-C47E/4 engine
- Basic inlet installed
- FMS-12 engine data



Helicopter Performance Charts

IGE HOVER CEILING

Conditions:

- Rolls-Royce 250-C47E/4 engine at takeoff power
- Basic inlet installed

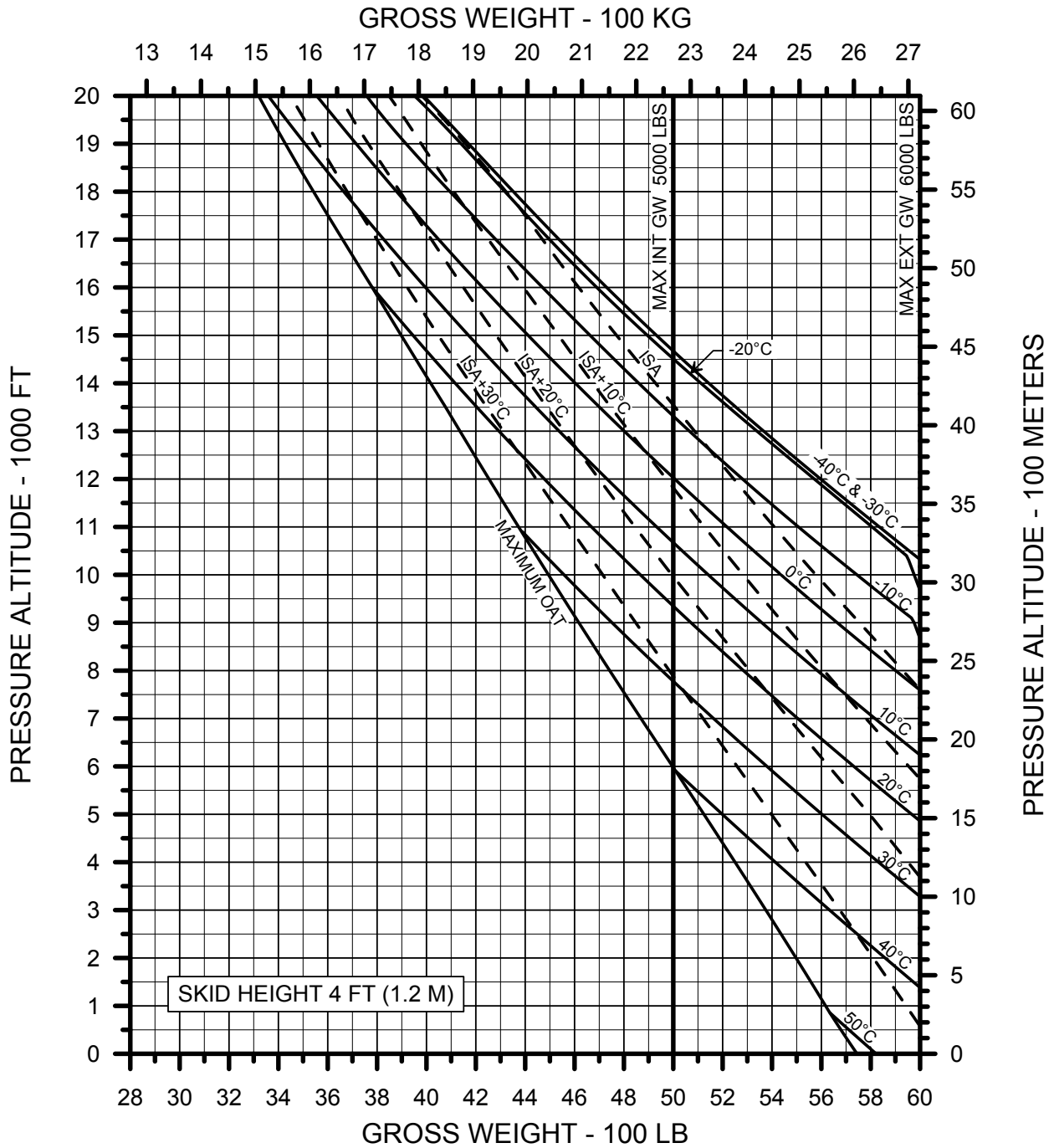

Note: Takeoff and Landing is approved up to 20,000 feet (6,096 meters) density altitude. Demonstrations were made up to 25,000 feet (7620 meters) density altitude.

Helicopter Performance Charts

OGE HOVER CEILING

Conditions:

- Rolls-Royce 250-C47E/4 engine at takeoff power
- Basic inlet installed

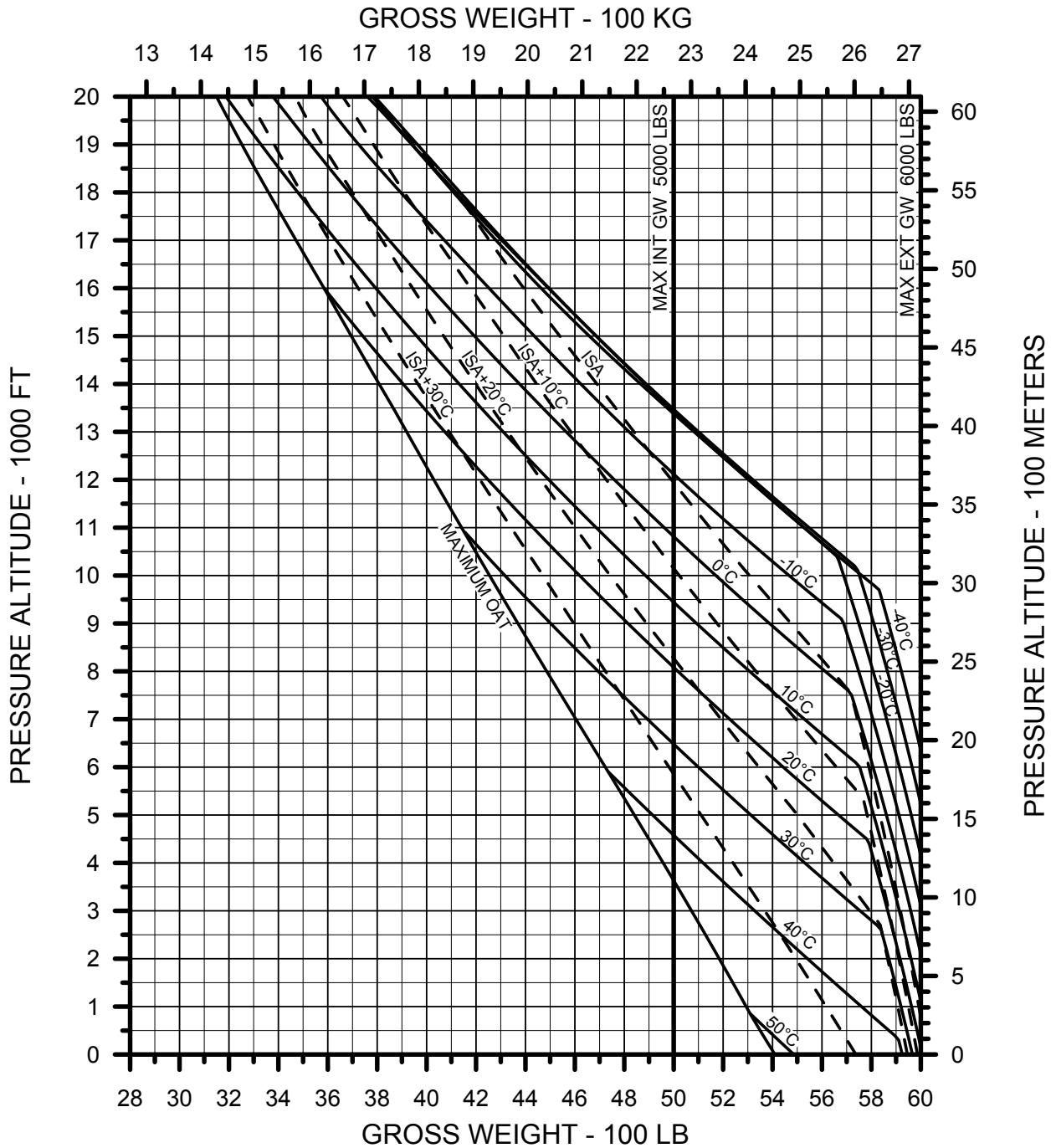

Note: Takeoff and Landing is approved up to 20,000 feet (6,096 meters) density altitude. Demonstrations were made up to 25,000 feet (7620 meters) density altitude.

Helicopter Performance Charts

SERVICE CEILING

Conditions:

- Rolls-Royce 250-C47E/4 engine at maximum continuous power
- Basic inlet installed

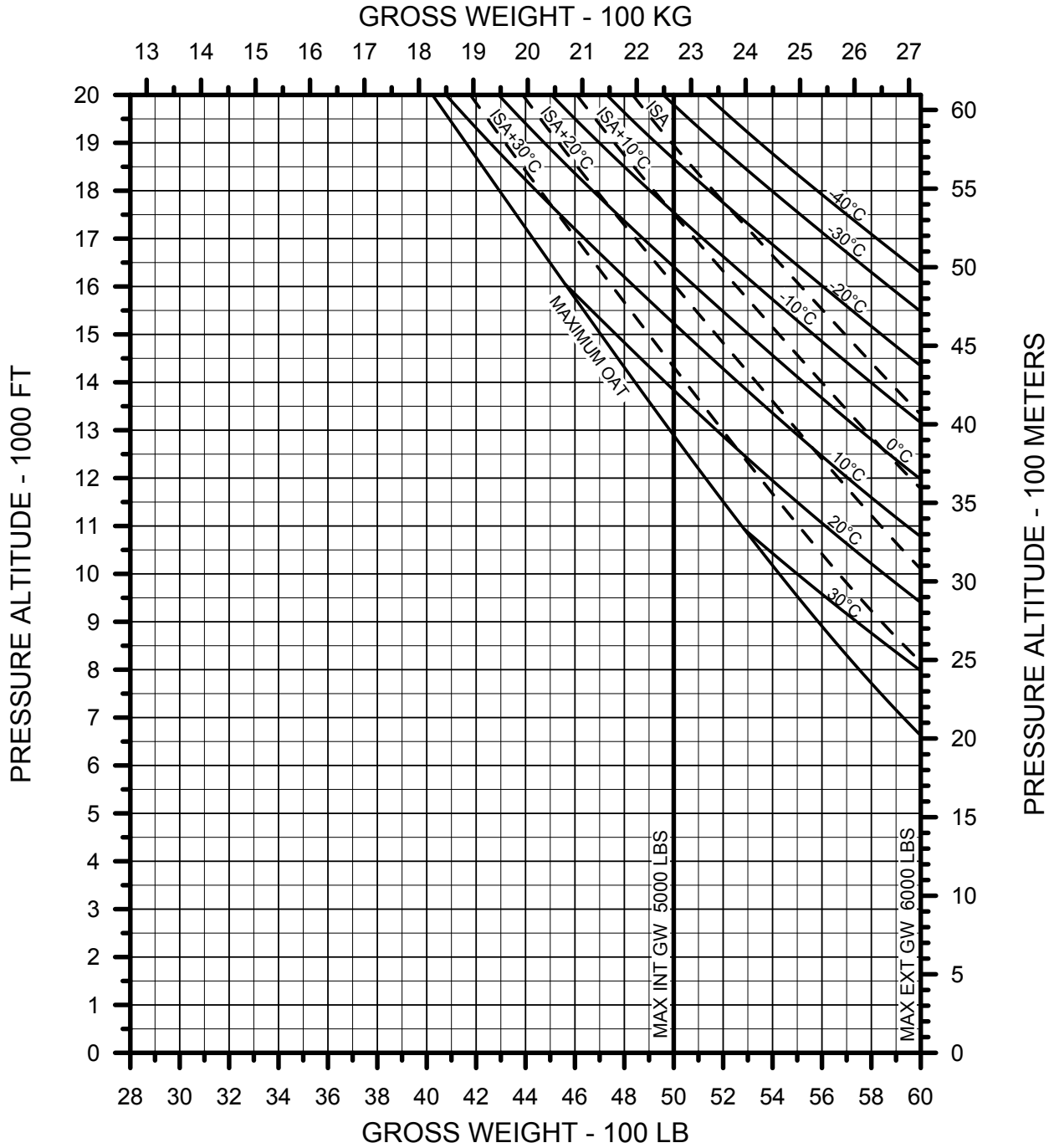

Note: Takeoff and Landing is approved up to 20,000 feet (6,096 meters) density altitude. Demonstrations were made up to 25,000 feet (7620 meters) density altitude.

Helicopter Performance Charts

TAKE-OFF AND LANDING LIMITATION

Conditions:

- Optional 5,250 lb / 2,381 kg Internal Gross Weight Kit
- Rolls-Royce 250-C47E/4 engine at Maximum Continuous Power
- Basic inlet installed

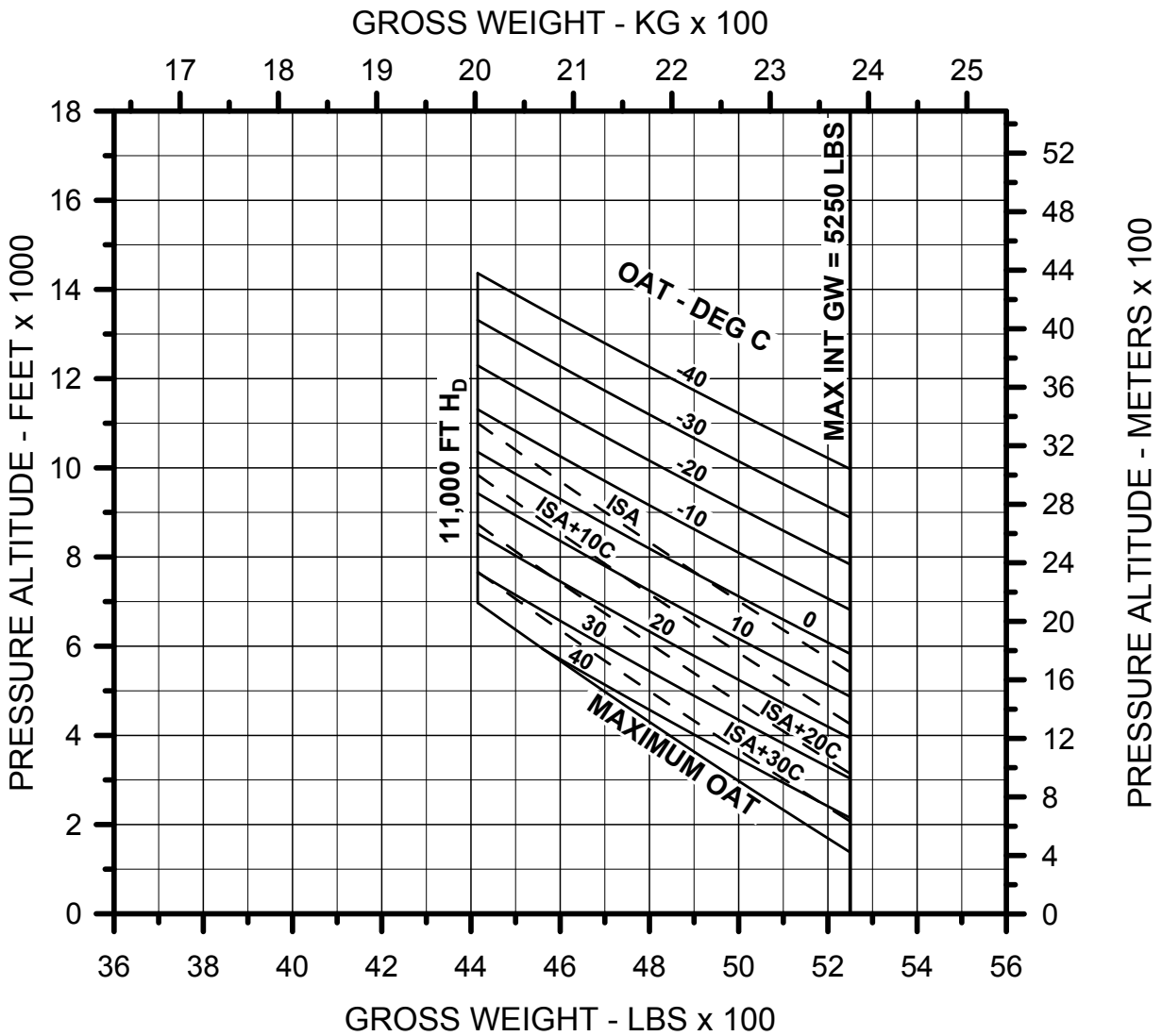

Fuel Flow vs. Airspeed Charts

Fuel Flow vs. Airspeed chart data based on the following conditions:

- ISA & ISA+20°C
- Rolls-Royce 250-C47E/4 engine
- Basic inlet installed
- Low skid gear without fairings with FMS-12 engine data

Notes: For particle separator installed: Increase fuel flow 2 lb/hr (1 kg/hr)
For cross tube fairings: Increase airspeed 3 knots (5 km/hr)
Recommended cruise speed is the Long Range Cruise (LRC) Speed.



Fuel Flow vs. Airspeed

PRESSURE ALTITUDE = SEA LEVEL, OAT = 15°C (ISA)

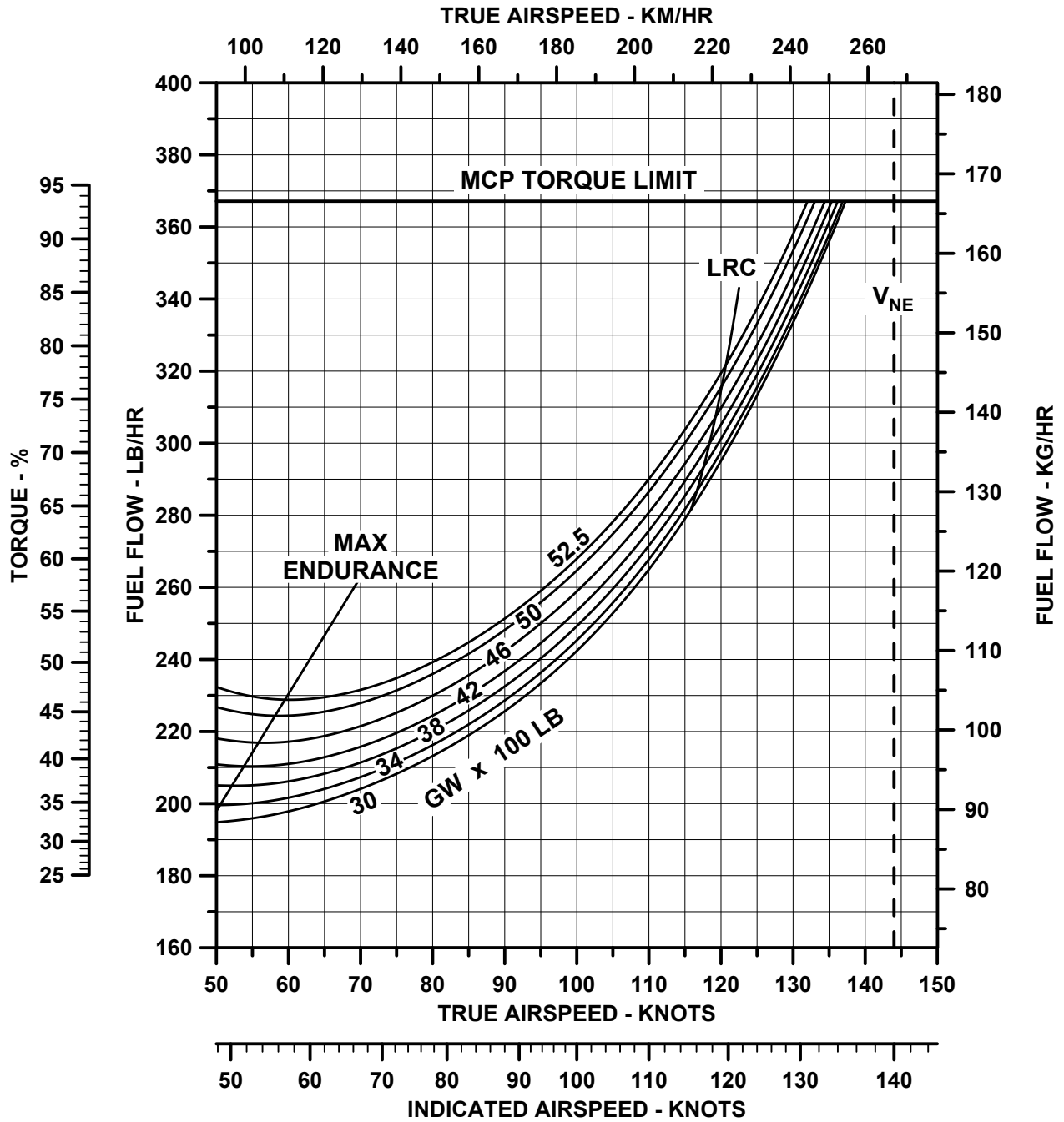

Fuel Flow vs. Airspeed

PRESSURE ALTITUDE = 2,000 FT, OAT = 11°C (ISA)

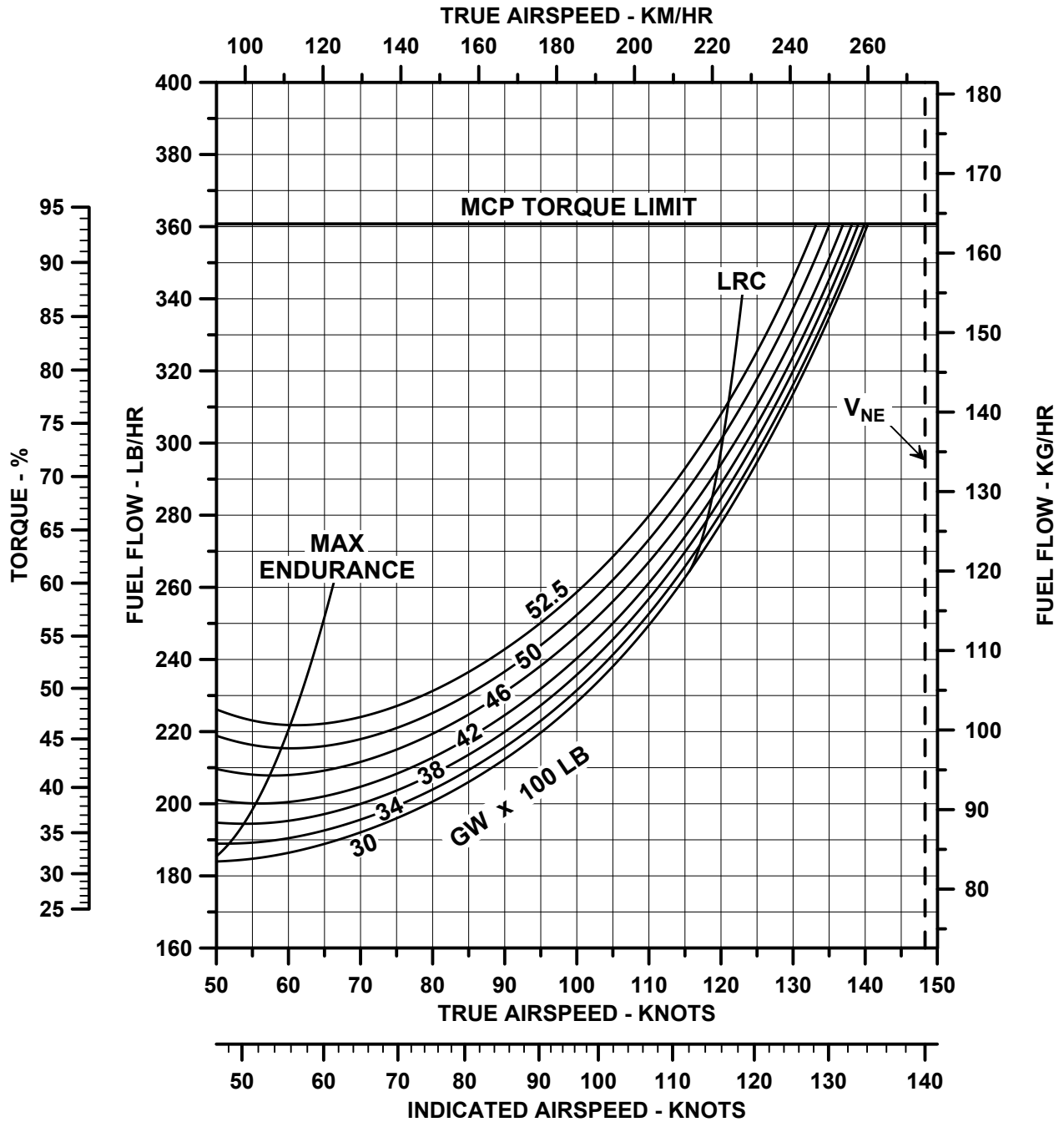

Fuel Flow vs. Airspeed

PRESSURE ALTITUDE = 4,000 FT, OAT = 7°C (ISA)

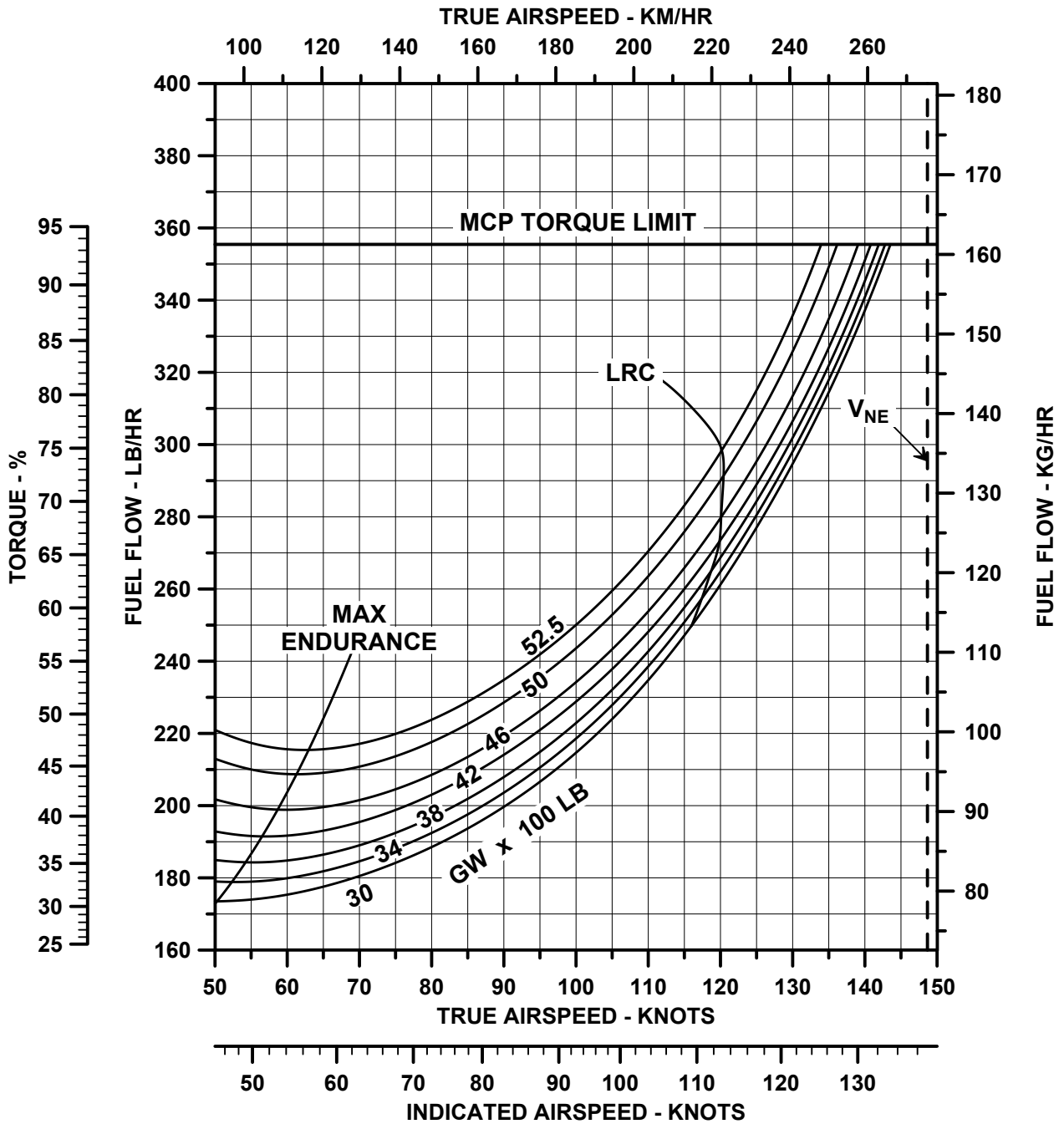

Fuel Flow vs. Airspeed

PRESSURE ALTITUDE = 6,000 FT, OAT = 3°C (ISA)

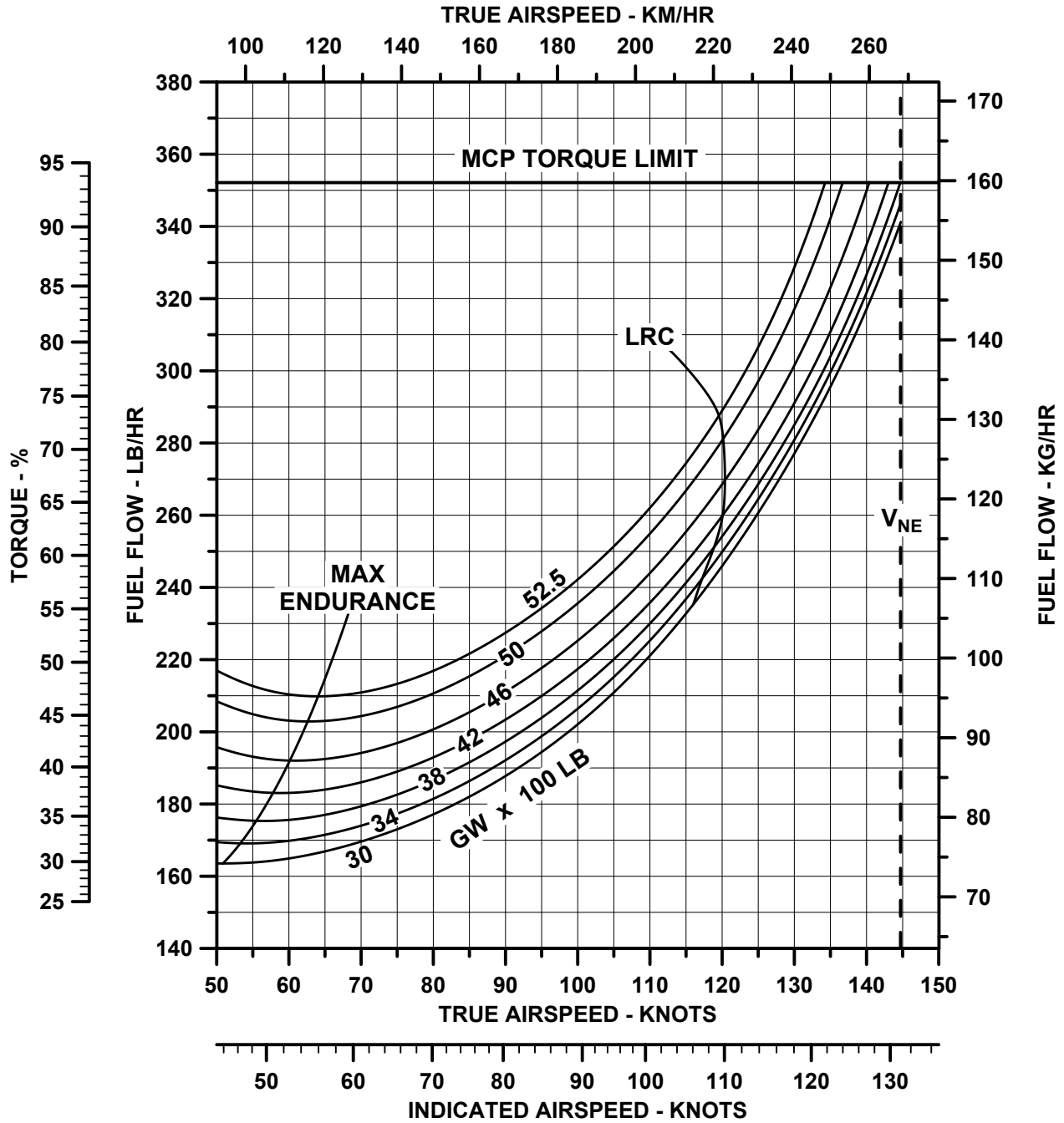

Fuel Flow vs. Airspeed

PRESSURE ALTITUDE = 8,000 FT, OAT = -1°C (ISA)

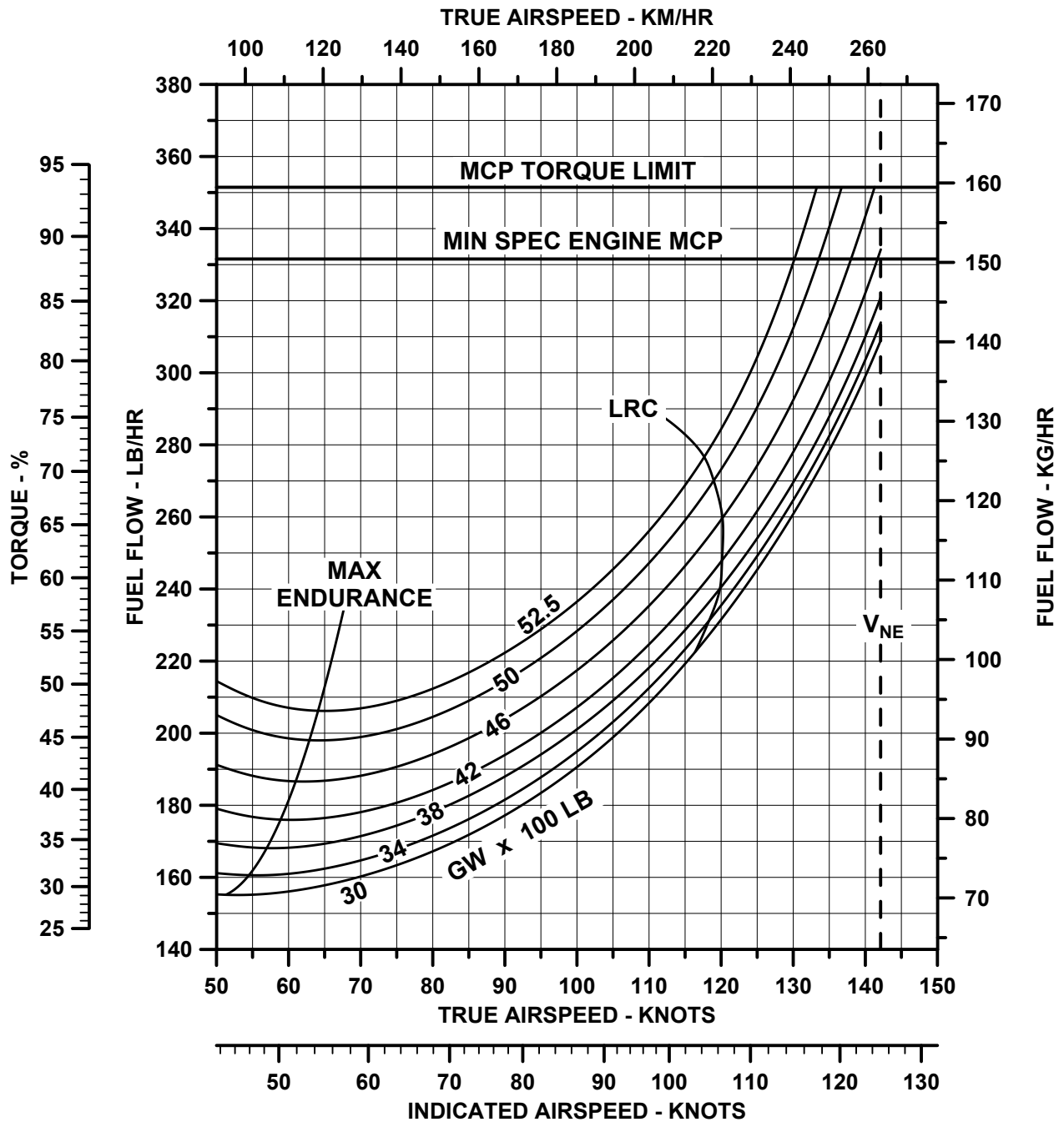

Fuel Flow vs. Airspeed

PRESSURE ALTITUDE = 10,000 FT, OAT = -5°C (ISA)

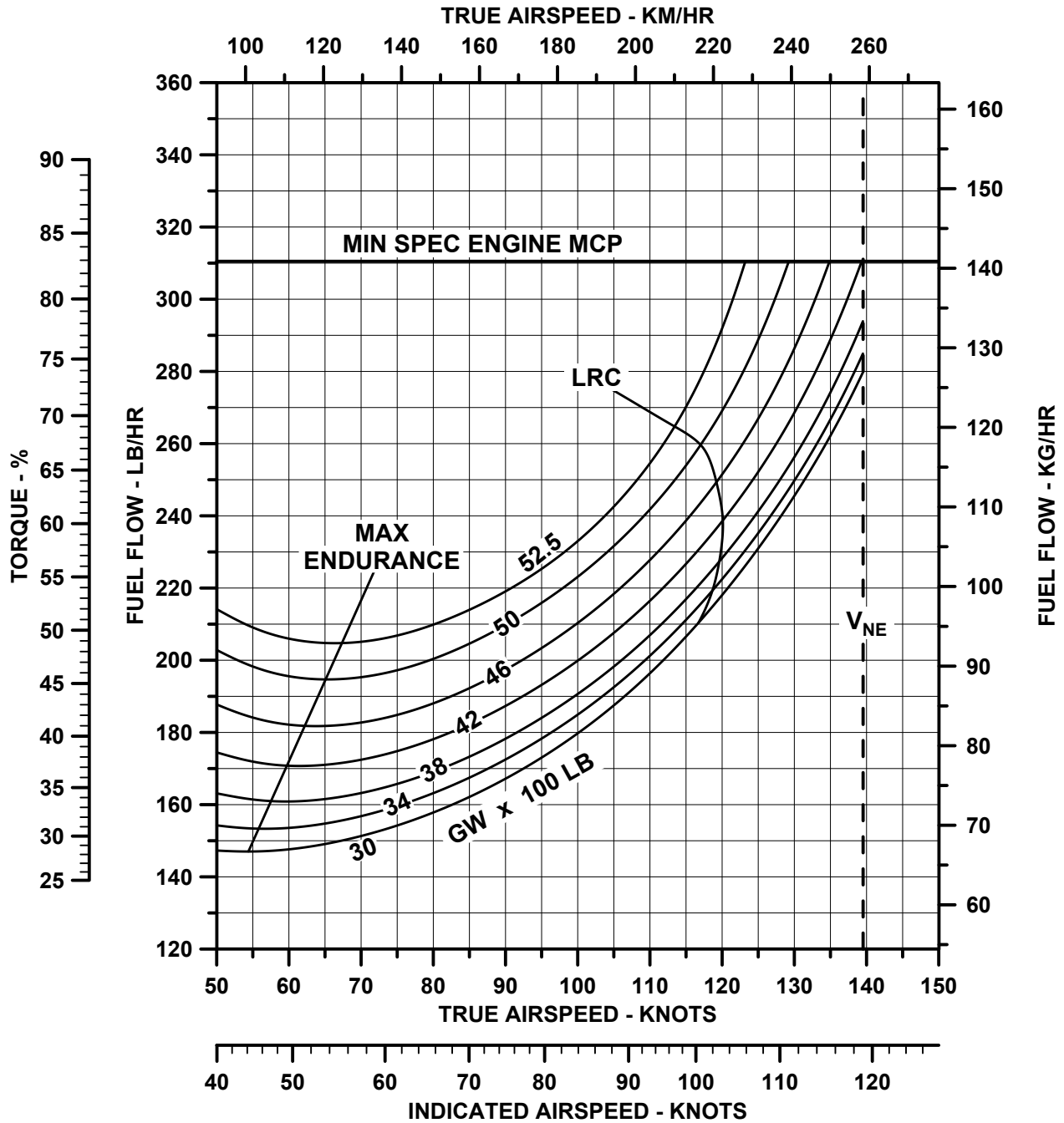

Fuel Flow vs. Airspeed

PRESSURE ALTITUDE = SEA LEVEL, OAT = 35°C (ISA + 20)

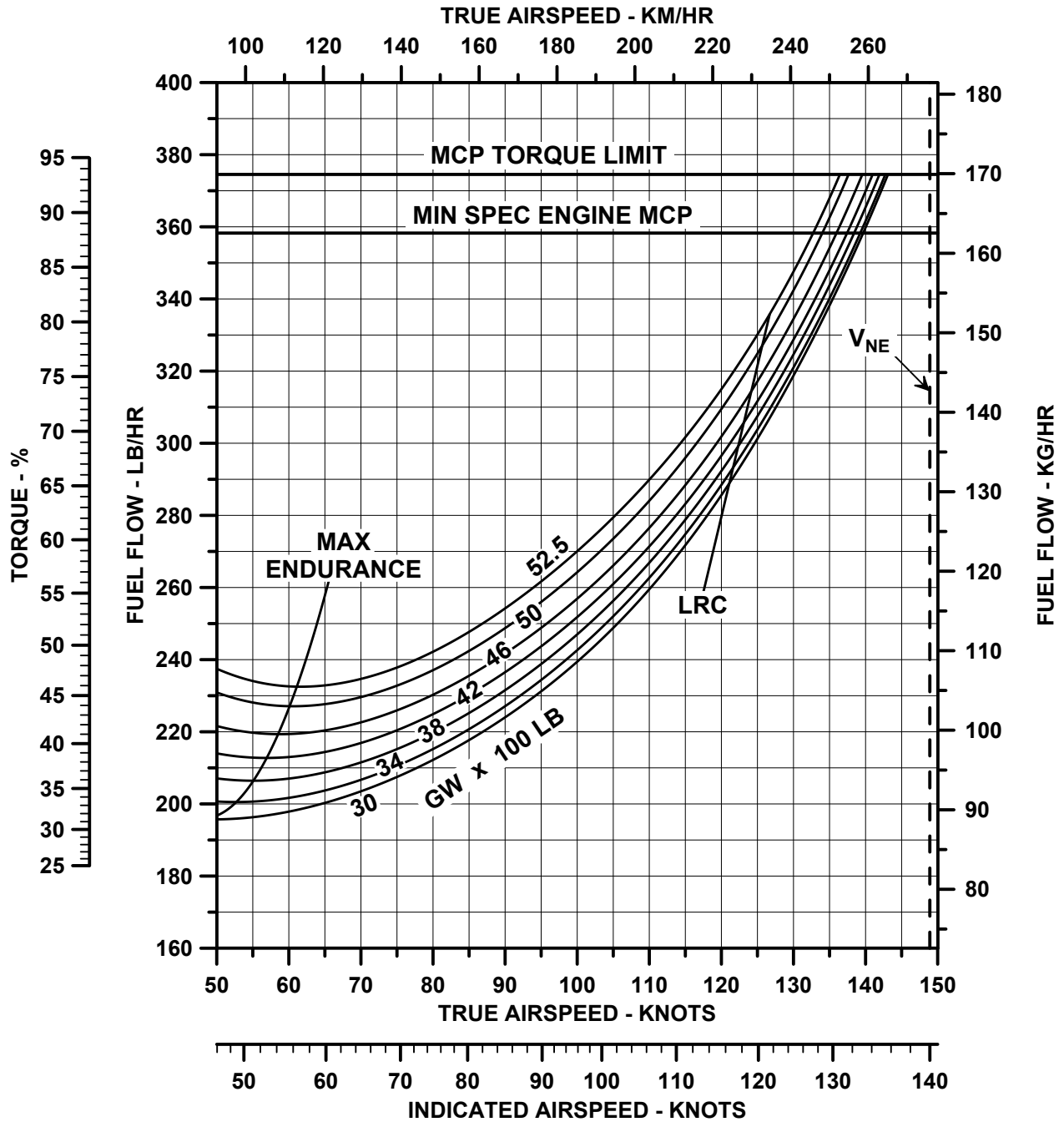

Fuel Flow vs. Airspeed

PRESSURE ALTITUDE = 2,000 FT, OAT = 31°C (ISA + 20)

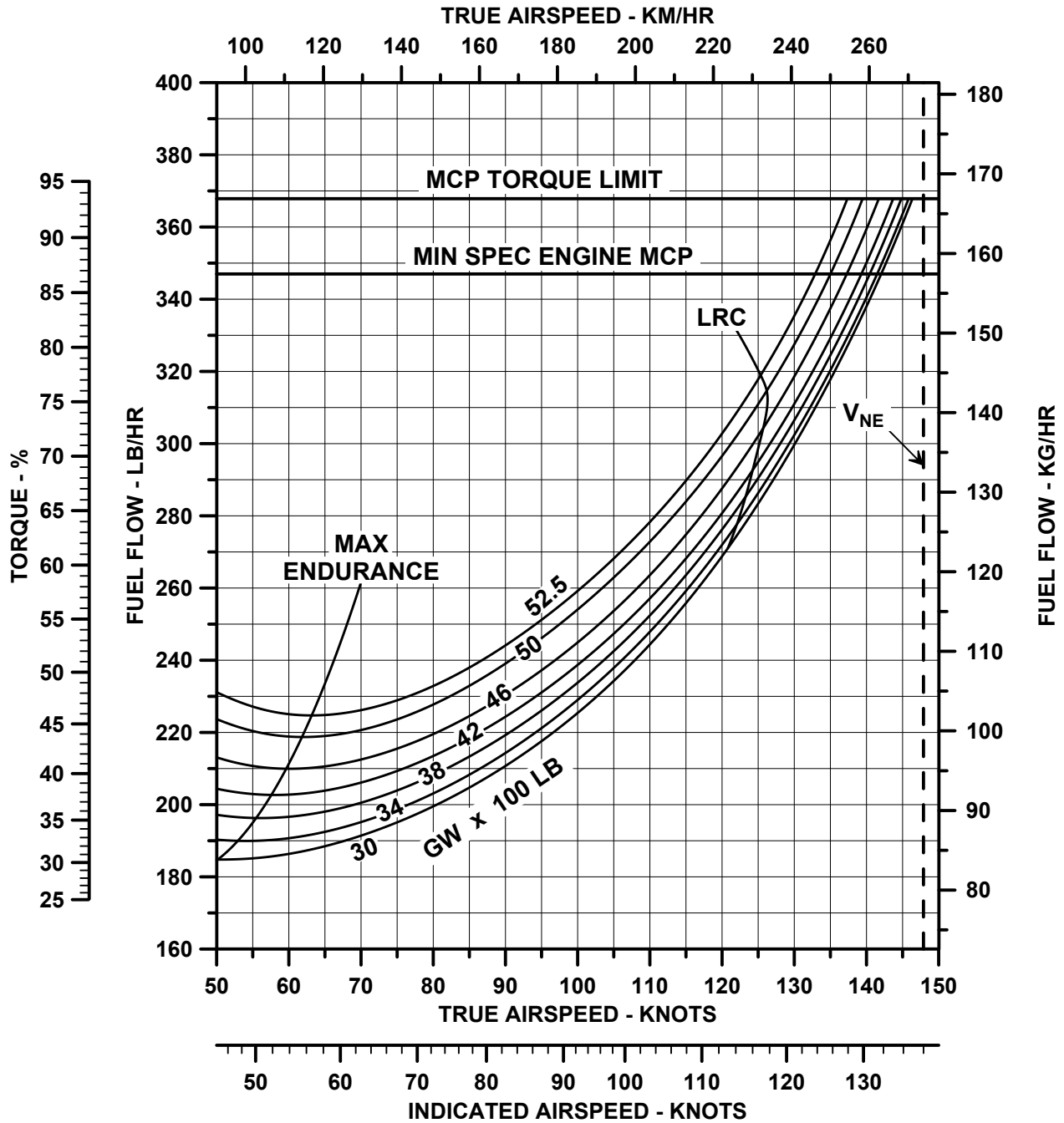

Fuel Flow vs. Airspeed

PRESSURE ALTITUDE = 4,000 FT, OAT = 27°C (ISA + 20)

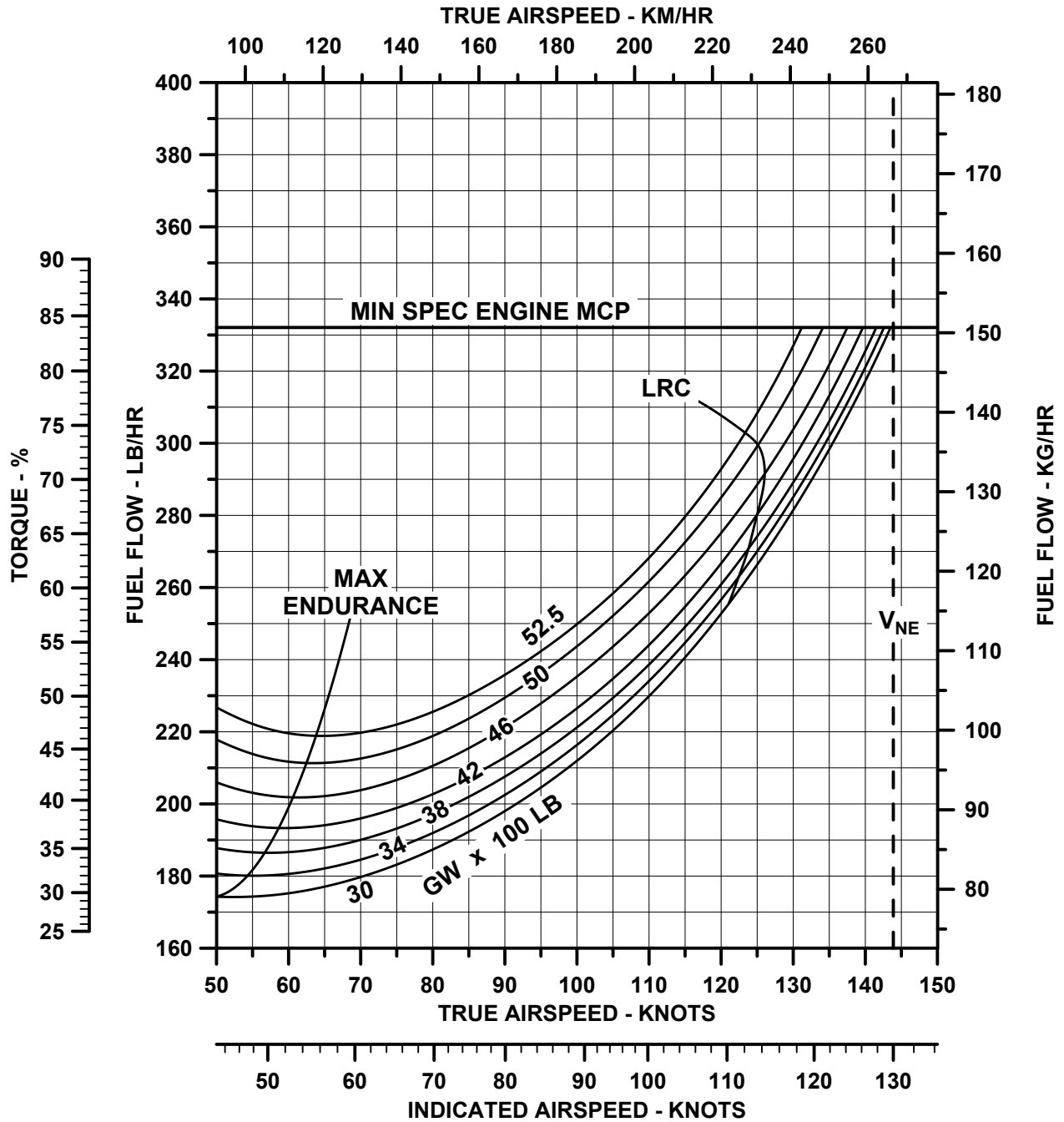

Fuel Flow vs. Airspeed

PRESSURE ALTITUDE = 6,000 FT, OAT = 23°C (ISA + 20)

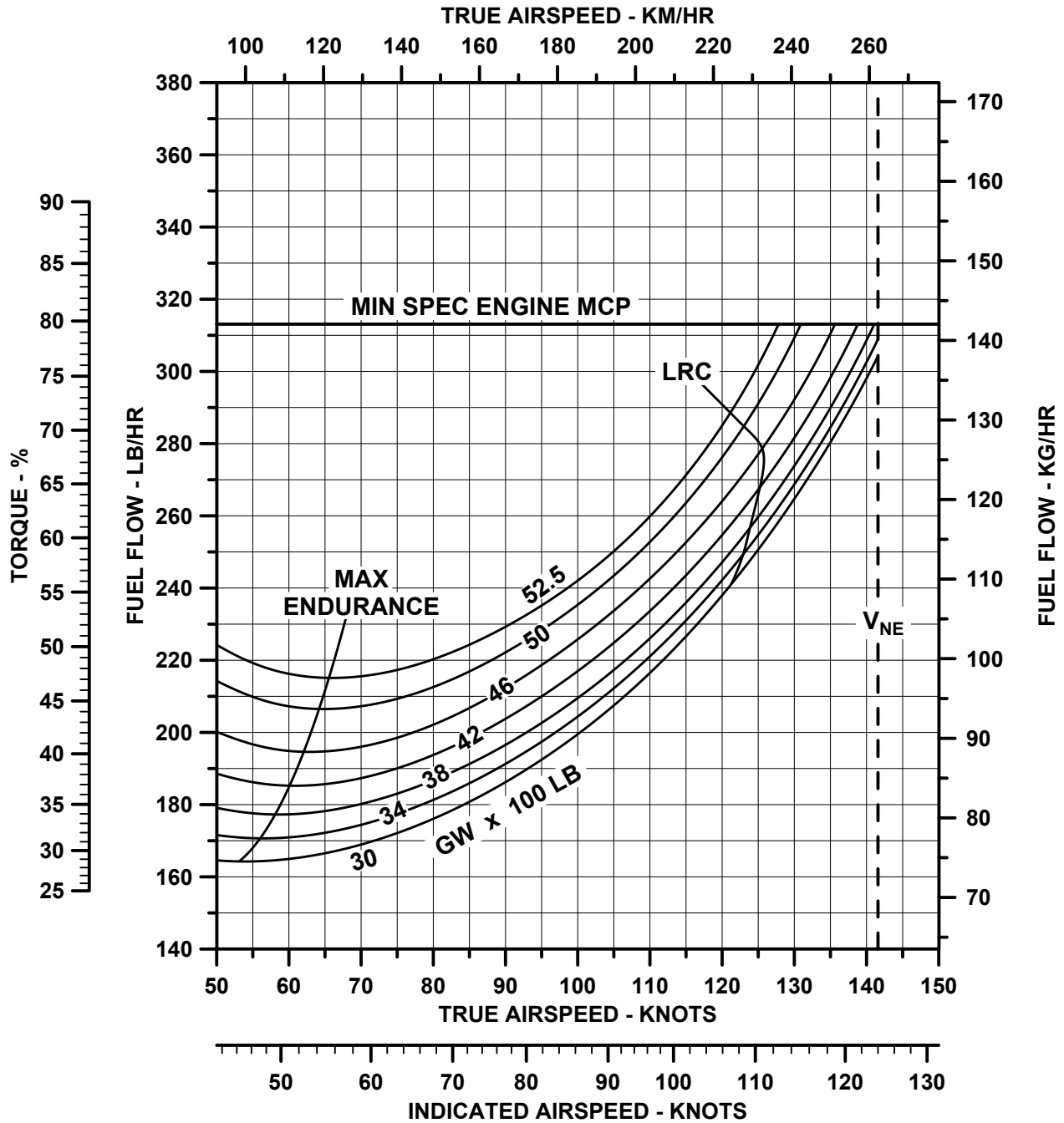

Fuel Flow vs. Airspeed

PRESSURE ALTITUDE = 8,000 FT, OAT = 19°C (ISA + 20)

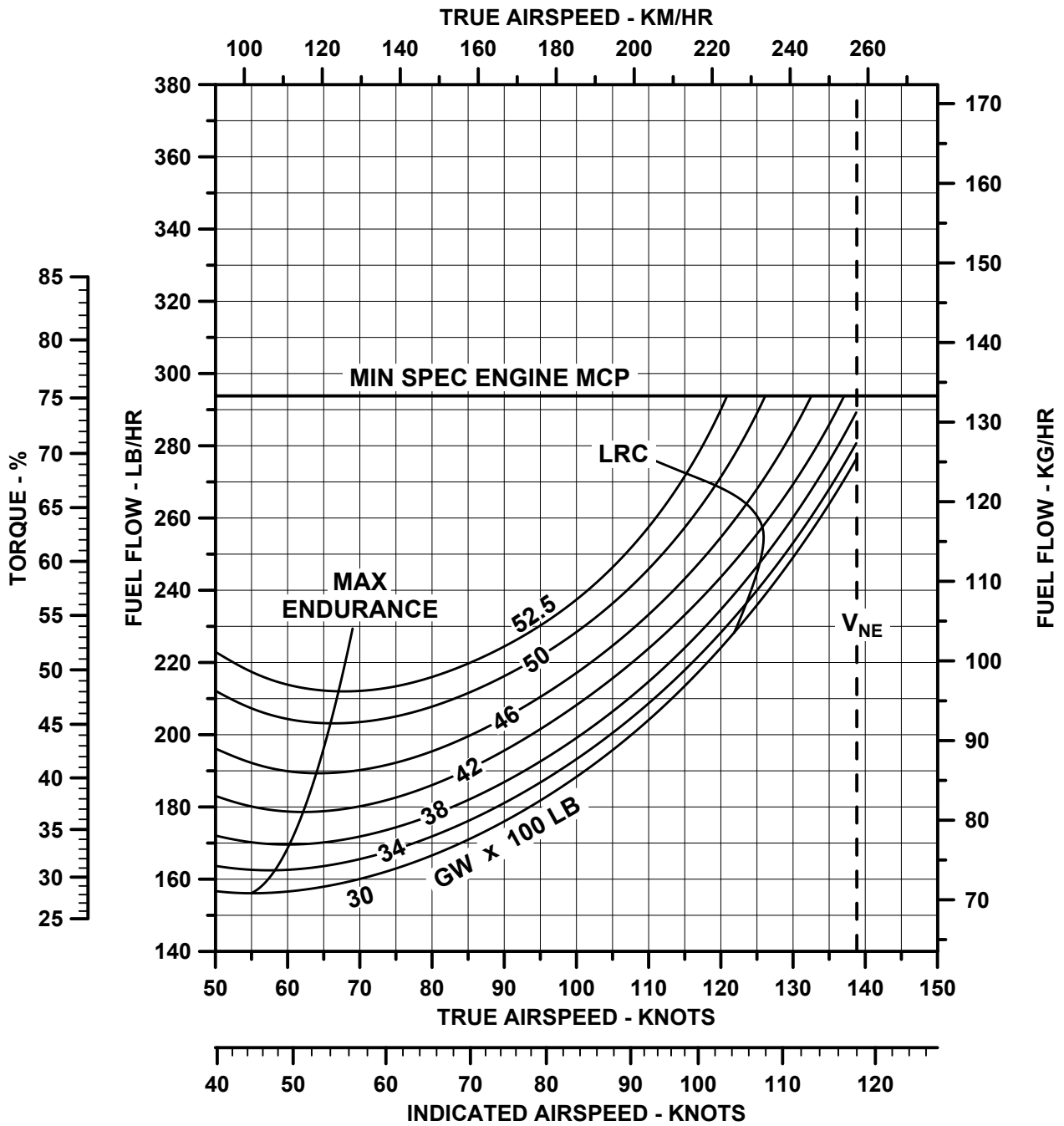

Fuel Flow vs. Airspeed

PRESSURE ALTITUDE = 10,000 FT, OAT = 15°C (ISA + 20)

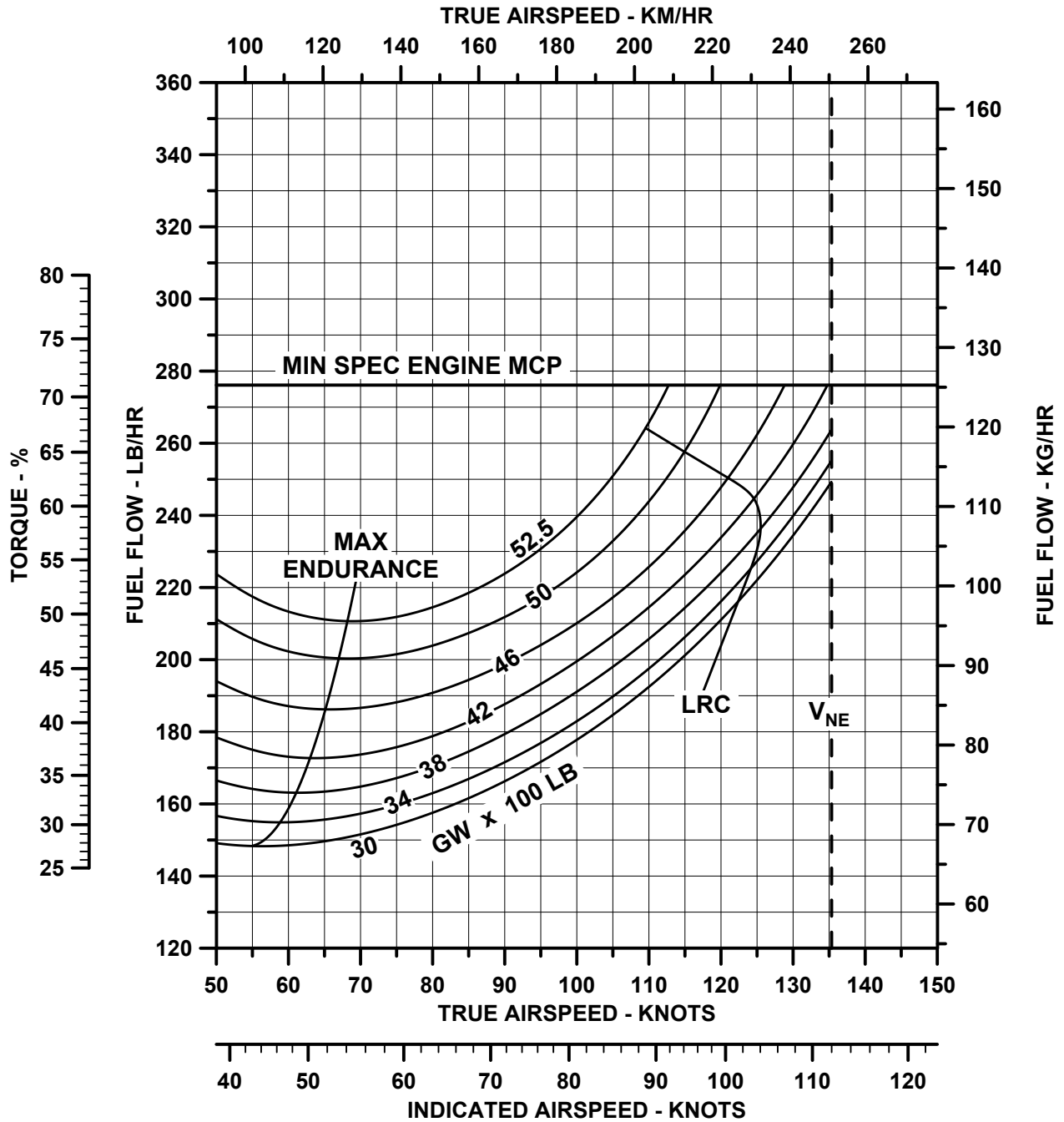

Cost of Operations

INTRODUCTION

Bell Textron Inc. cost of operations data for current production helicopters is based on information from Bell operators and service facilities. BTI's Product Support organization accumulates cost data from a diverse group of operators - large, small; sub-polar, subtropical; inland, coastal; corporate, charter. This information is analyzed to generate sample data for each production model which are averages of the field experience. BTI intends to continue monitoring actual costs and product improvements to enable annual updates of the data to maintain its currency. The following discussion is provided to review the variables involved in the helicopter's direct and indirect cost of operations as well as its cost of ownership.

The total cost of helicopter ownership and operation involves both direct and indirect costs. The direct costs are those which are incurred essentially by the flight hour and include:

- Fuel, Lubricants
- Basic Airframe Maintenance
- Powerplant Maintenance

The indirect costs are not directly dependent upon the number of hours flown and include:

- Insurance
- Facilities (hangar, workshop, etc.)
- Crew Compensation
- Financial Factors (depreciation, investment tax credit, financing costs, etc.)

DIRECT COSTS

Fuel, Lubricants	A typical average value of fuel and lubricant costs is included in the sample data provided for each model. Fuel consumption depends upon speed, temperature, externally-mounted accessories, sling loads, etc. A band of approximately 10% more or less than sample value will cover these factors for normal operations. Fuel pricing varies considerably based on where the fuel is purchased geographically and whether it is purchased retail or in bulk. The sample cases use average retail purchase price prevalent at the time of the sample data are prepared.
Basic Airframe Maintenance	<p>Airframe maintenance is divided into four categories:</p> <ul style="list-style-type: none"> • Periodic Inspections • Overhauls • Replacement of Retirement Parts • Unscheduled <p><u>Periodic inspections</u> include those inspection tasks, with their part requirements, listed in the Maintenance Manual for each model. Man hours for periodic inspections can vary from the sample value provided because of differences in personal experience, tool and parts availability, facilities, environmental effects such as extremes in working temperatures. Man hour costs/hour are also variable among the Authorized Service Centers as a result of differences in local costs, overhead expenses and volume of work. The sample value is an average of costs per hour at Authorized Service Centers at the time of publication.</p>

Cost of Operations

DIRECT COSTS

<p>Basic Airframe Maintenance (continued)</p>	<p><u>Overhauls</u> include removal, disassembly, inspection, parts replacement, reassembly and reinstallation of certain components/assemblies at the periods stated in the BTI Maintenance Manual. Overhaul man hour and parts requirements are subject to considerable variation depending upon the helicopter’s operations and environments. The sample data reflect average values.</p> <p><u>Retirement parts</u> are those which are subject to disposal after an operating time stated in the Maintenance Manual. These are normally components of the rotors/control systems which are subject to oscillatory loads and are designed and tested for use over a finite number of flight hours rather than on their condition. The replacement at the required intervals requires some labor which is included in the man hour data in the sample.</p> <p><u>On-condition/Unscheduled maintenance</u> encompasses labor and parts replacement for major maintenance not covered under the formal Maintenance Manual requirements for scheduled part retirements, periodic inspections and overhauls. It also includes those additional maintenance requirements imposed by the manufacturer through issue of Service Bulletins.</p> <p>The sample data for periodic inspections provide for some minor unscheduled maintenance tasks resulting from the inspection.</p>
<p>Powerplant Maintenance</p>	<p>The powerplant (engine) requires periodic inspection and overhauls. The overhaul periods are based on the number of operating hours or on the number of cycles, whichever is the first limit to be attained. Start cycles are a factor because thermal cycles are important in the design of the turbine engine’s rotating components. Overhauls are performed by the engine manufacturer and/or at authorized facilities. Powerplant overhaul can be performed for the engine as a unit, or in some cases for individual modules. (Modules can be gearbox, compressor, turbine, for example.) Each module can have its own overhaul period. Modular overhaul can be cost-effective for some operations and its use should be evaluated. Engine or module exchanges can be made in lieu of overhaul. For details, contact the engine manufacturer or his authorized distributors/service centers. The sample costs are based on an average exchange. The powerplant may also require unscheduled maintenance (unscheduled removals for repair, parts replacement).</p>

Cost of Operations

The following table is a sample of the Bell 407GX_i direct cost of operations, in U.S. dollars per flight hour. This sample is developed by Bell using the Guide for the Presentation of Helicopter Operating Cost Estimates published in 2010 by Helicopter Association International.

SAMPLE BELL 407GX_i DMC (PLUS FUEL ESTIMATE) SUMMARY SCHEDULE

	Parts	Labor ^[1]	Total
BASIC AIRFRAME MAINTENANCE			
Scheduled Inspections ^[2]	\$6.63	\$16.49	\$23.12
Scheduled Retirements ^[3]	\$46.04	\$0.57	\$46.61
Scheduled Overhauls ^[4]	\$64.28	\$8.43	\$72.71
Provision for Unscheduled Maintenance and Service Bulletins on above Components	\$13.76	\$1.29	\$15.05
On-condition Maintenance of Other Airframe Components	\$83.33	\$58.43	\$141.76
Subtotal	\$214.04	\$85.22	\$299.25
0.90 Mx Man-Hour / Flt. Hr			
POWERPLANT			
ROLLS-ROYCE ALLISON MODEL 250-C47E/4 (QUANTITY 1)			
Mfr. Estimate of Engine Cost per hour (Includes overhaul, accessory repairs, impeller and overhauls)			\$255.43
		Subtotal	\$255.43
		Total DMC	\$554.69
FUEL AND LUBRICANTS			
Fuel ^[5]			\$220.00
Lubricants			\$2.20
		Subtotal	\$222.20
		Grand Total with Fuel	\$776.89

- Notes:
- [1] Labor rate figured at \$95.00 per hour.
 - [2] Based on 600 flight hours / year, 1.5 RIN/flight hour.
 - [3] Based on 100% Life.
 - [4] Based on 100% TBO.
 - [5] Calculated at 44 GPH at \$5.00 per gallon.

Other assumptions: Basic VFR helicopter with no optional equipment installed;
Mature helicopter (no warranty considerations);
Bell list price for spare parts.

Cost of Operations

INDIRECT COSTS

Insurance	Insurance rates are based on a number of factors including claim experience, type of operations, and crew qualifications. Rates can be obtained from insurance agent/broker.
Facilities	Facilities can include hangar, workshop, parts storage area, tools, ground support equipment and administrative area as appropriate to the specific operation.
Crew Compensation	The number of aircrew personnel depends on the individual operation; i.e., whether the normal crew consists of one or two pilots, hours per day flown, backup requirements for illness, vacation, etc. Bell regional marketing managers can advise typical local costs for estimation purposes.
Financial Factors	Funding a helicopter purchase can be accomplished in a variety of ways, including cash, short term note, long term note, partnership, etc. For investment accounting, several depreciation methods also exist; straight line, double declining, sum of the years digits, etc. Value of resale is a significant factor.
Miscellaneous Factors	Staff expenses (other than aircrew and direct maintenance personnel), utilities, office expenses, etc.

OWNERSHIP ANALYSIS PROGRAM

Bell uses the most recently published edition of the Life Cycle Cost computer program provided by Conklin & de Decker Associates, Inc. to determine total ownership costs for an operators planned period of utilization for the aircraft.

Bell's regional marketing managers or corporate office personnel will be able to assist in preparing an ownership analysis which is customized for our customers specific individual conditions and needs. To request a Life Cycle Cost Analysis, contact your sales representative or call 1-800-FLY-BELL.

Component Overhaul

COMPONENT OVERHAUL INTERVALS

Component	Hours	Component	Hours	Component	Hours
M/R Hub	2,500	Swashplate	2,500	Rotor Brake Caliper Assy	3,600
Mast Assy	2,500	Tail Rotor Gearbox	5,000	Rotor Brake Disk	12,000
Transmission	6,000	Tail Rotor Hub	2,500	Starter Generator	1,200
Freewheeling Assy	3,000	K-Flex Drive Shaft	2,500		

Note: Analysis of Lead-the-Fleet performance data continues to permit extension of TBOs beyond 2,500 hours for drive train components.

LIMITED LIFE COMPONENTS

Part Number	Component	Life Limit (hours)	Qty Per Aircraft
MAIN ROTOR HUB AND BLADES			
406-010-108-131	Main Rotor Grip	5,000	4
406-010-115-127	Main Rotor Upper Plate	2,500	1
406-010-117-125	Main Rotor Lower Plate	2,500	1
406-010-126-113	Drive Ring Set	100,000 RIN	1
MAIN ROTOR CONTROLS / SWASHPLATE ANTI-DRIVE			
406-010-432-101	Anti-Drive Link	5,000	1
406-010-431-109	Anti-Drive Lever	5,000	1
407-001-524-109	Collective Transmission Bellcrank	5,000	1
407-001-526-109	Cyclic Longitudinal Bellcrank	5,000	1
407-001-528-105	Cyclic Lateral Transmission Bellcrank	5,000	1
407-001-511-101	Bell Crank Support	5,000	1
TAIL ROTOR			
406-012-102-109	Tail Rotor Yoke	5,000	1
DRIVE SYSTEM			
407-040-038-123	Main Rotor Mast	6,300	1
PYLON SUPPORT			
407-010-201-105	Left Hand Pylon Side Beam	5,000	1
407-010-203-105	Right Hand Pylon Side Beam	5,000	1
407-010-206-103	Pylon Restraint Spring	5,000	2
LANDING GEAR			
407-722-101 or 407-724-101	Forward Crosstube (Low or High Gear)	5,000 RIN	1
407-723-104 or 407-725-104	Aft Crosstube (Low or High Gear)	5,000 RIN	1

Notes: Prices and hours are subject to change without notice. These data are provided for illustration purposes. Consult maintenance documents and BTI spare parts pricing for current, official information.

Global Customer Solutions

As the industry leader in customer support, we at Bell pride ourselves on supporting our customers around the world at every step of your aircraft's life cycle. We are committed to providing customers with an extensive range of support and service capabilities as well as replacement parts and accessories to ensure safe and reliable operation of our products, enhance mission execution, and keep you flying through Bell's Global Customer Solutions.



MYBELL

MyBell is a user-friendly customer portal to view technical publications, order parts, file warranty claims, submit requests for customer support, and much more.

Who's Using MyBell?

- 14,000+ users worldwide
- Bell owners, operators, and maintainers
- Customer service facilities
- Part 145 maintenance centers
- Government agencies (Technical Publications)

What Can I Do In MyBell?

- Access your technical publications
- Buy spare parts
- File a claim or start a part return
- Training registration
- Contact Bell for support
- Access the SABA training system
- Find external resources
- Submit cases to product support

INDUSTRY LEADING 24/7/365 SUPPORT

Bell is dedicated to supporting our customers wherever and whenever you need it. We have experienced and knowledgeable Customer Service Engineers (CSE) to provide local technical support and Product Support Engineering (PSE) to provide advanced, in-depth technical assistance from the Bell office. The Bell technical support team provides global Bell aircraft owners and operators with trusted and timely technical service that promotes safe aircraft maintenance and operation.

Customer Service Engineers

Your regional technical support and liaison to other Bell departments for in-production and legacy aircraft

Product Support Engineers

Around-the-clock OEM support with extensive product knowledge for in-production and legacy aircraft.

45+

CSE's regionally located throughout the world

30+

PSE's located throughout our three global offices (U.S.A., Canada and Singapore)

Global Customer Solutions

CUSTOMER ADVANTAGE PLANS (CAP)

Bell's Customer Advantage Plan (CAP) is an aircraft component solution designed to simplify operations, control costs, and maximize aircraft readiness. CAP enables customers to benefit from a contracted hourly rate, around-the-clock support, & component exchanges from a dedicated inventory.

General Features & Benefits

- Simplified Budgeting – CAP's contracted hourly rate aligns costs with flight hours.
- Avoid Surprises – All CAP plans provide coverage for unscheduled maintenance events. When something breaks, simply file a claim.
- Faster Return-to-Service – CAP provides component exchanges from a dedicated inventory, strategically positioned across the world, eliminating delays associated with repair or overhaul activities.
- Freight – CAP covers shipping costs for parts sent to customers under the plan. In Aircraft on Ground (AOG) situations, CAP provides expedited shipping at no additional cost, enabling a swift resolution to return the aircraft to service.
- 24/7/365 Global Support – The CAP team is strategically positioned across the globe, ensuring customers receive seamless, round-the-clock support.
- Optional Kit Coverage – Coverage determined on a case-by-case basis.

Available Plans

CAP Premier Plan

CAP Premier is the most comprehensive offering under CAP, providing coverage for unscheduled maintenance events, as well as for scheduled retirements & overhauls. CAP Premier helps amortize the cost of these major scheduled maintenance events, reducing cost spikes and simplifying budgeting. CAP Premier features a 5-year term, monthly flight hour reporting & billing, and has a 200 hour/year flight hour minimum. CAP Premier is available for new and fielded aircraft.

CAP Standard Plan

CAP Standard provides coverage for unscheduled maintenance events and is only available to new aircraft. CAP Standard features a 5-year term with monthly flight hour reporting & billing.

CAP Executive (505, 407, & 429 only)

CAP Executive provides coverage for unscheduled maintenance events and is only available to fielded aircraft outside of warranty coverage. The CAP Executive plan features a single, up-front payment, no flight hour reporting, and is available in 2 term options:

- 1 year / 100 flight hours
- 1 year / 200 flight hours

Global Customer Solutions

	Premier	Standard	Executive
Unscheduled Coverage	<input checked="" type="checkbox"/>	<input checked="" type="checkbox"/>	<input checked="" type="checkbox"/>
Scheduled Coverage	Retirements & Overhauls	<input type="checkbox"/>	<input type="checkbox"/>
Component Exchange	<input checked="" type="checkbox"/>	<input checked="" type="checkbox"/>	<input checked="" type="checkbox"/>
Term Length (Years)	5	5	1
Term Length (Flight Hours)	Unlimited	Unlimited	100 or 200
Flight Hour Reporting	Monthly	Monthly	None
Billing / Payment	Monthly (Negotiable)	Monthly	Single, Up-Front
Minimum Annual Hours	200	None	None
Aircraft Age	Any	New	Post-Warranty
Renewable	<input checked="" type="checkbox"/>	<input type="checkbox"/>	<input checked="" type="checkbox"/>
Transferable*	<input checked="" type="checkbox"/>	<input type="checkbox"/>	<input type="checkbox"/>

*Contract terms and conditions apply

Global Customer Solutions

SERVICE CENTERS

Bell's Global Customer Solutions provides customers with a complete and seamless support system offering a full service experience anywhere in the world.

With a suite of available services including aircraft customizing, maintenance repair and overhaul, and Bell warranty work, our service centers offer direct OEM support in every corner of the world.

CAPABILITY AND LOCATIONS

● In-house capabilities ▲ Outside services

	Piney Flats, TN	Miami, FL	Singapore	Prague	China	Mirabel, Canada	Broussard, LA	RBI Hawker (UAE)	RBI Hawker (Australia)	RBL (United Kingdom)	Australia
COMPONENT REPAIR AND OVERHAUL CAPABILITIES											
Expanded repair	●	●	▲	●	▲	▲					▲
Transmission	●	●	●	●	▲	▲					●
Hubs	●	●	●	●	▲	▲					●
Avionics	●	▲	▲	▲	●	▲					▲
Rotor blades	▲	▲	▲	▲	▲	▲	●	●	●	●	▲
Composite panels	▲	▲	▲	▲	▲	●	●				▲
ADDITIONAL CAPABILITIES											
Aircraft customizing	●	▲	●	●	●	●					●
Retrofits, modifications and upgrades	●	●	●	●	●	●					●
Approved installer of Aeronautical Accessories parts and accessories	●	●	●	●	●	●					●
Aircraft paint services	●	▲	●	●		●					●
Field maintenance and repair (remote)	●	●	●	●	●	●	●	●		●	●
Bell warranty work	●	●	●	●	●	●	●	●	●	●	●
Engine support and rental program	▲	▲	▲		▲						▲

For more information on each facility visit: bell.co/MRO

Global Customer Solutions

CUSTOMER SERVICE FACILITIES (CSF)

In addition to our 11 service centers, Bell has a strong network of more than 80 Authorized Customer Service Facilities (CSFs). These award-winning facilities enhance the accessibility of in-region global support and ensure that your aircraft is ready whenever and wherever you need it.

View digital map here: bellflight.com/support/commercial/contact-support



QUALITY ASSURED AND OEM APPROVED

Customers who choose an authorized CSF for maintenance, repair and overhaul work can be assured that both the staff members and the facility itself meet Bell's stringent internal standards for quality and safety. Authorized CSFs have factory-trained maintenance technicians and are equipped with the skills and expertise required to process Bell warranty claims. In addition, these facilities maintain guaranteed parts inventories to service aircraft and possess the most up-to-date technical and safety information available. All of this combines to provide in-region support you can trust.

Training

BELL TRAINING ACADEMY (BTA)

BellFlight.com/Training

Bell's global training solutions are designed to equip customers with the knowledge and skills necessary to perform their missions safely and efficiently. Since 1946, the BTA has been committed to providing industry leading training programs that create better, safer flight operations. The BTA staff of highly skilled professional pilot and technical instructors leverages OEM data and expertise to deliver the finest helicopter training in the world. We continue to develop innovative programs that will take our customers' pilot and technical skills to a whole new level.



The BTA at Bell's headquarters in Fort Worth, Texas.

Each purchase of a new aircraft comes with model specific complimentary training solutions. Supplemental training courses are available at an additional cost.

GENERAL INFORMATION

The operator and maintenance training provided by BTA establishes a foundation that supports mission tasks with aircraft pilot qualification.

The BTA's 100+ staff members welcome students from all over the world, and are eager to share the knowledge gained from decades of hands-on experience within the military and across other professions. Instruction can be provided in English or Spanish. Students are responsible for translation services if needed.

Pilot Operator Training: Our comprehensive pilot training program delivers platform-specific academics and flight training designed to transition qualified pilots seamlessly into Bell aircraft operations. All training is conducted by certified Bell instructor pilots.

Training Aircraft: The BTA conducts flight training in Bell OEM-owned or newly delivered customer aircraft.

Maintenance Technician Training: Experience is important, however, instruction received in the classroom and training lab provides an undeniable enhancement. Facilitating more efficient maintenance manpower and improving logistics supportability ensures that the customer's Bell is operational and maintainable in all types of climate and terrain.

Academic training includes both state-of-the-art instructor-led digital presentations and hands-on maintenance training. Mechanical, electrical, and avionics training takes place in a temperature-controlled shop and will include use of composite maintenance



trainers and avionics bench trainers. The BTA also has a composite repair room, and an electrical/avionics lab. Over half of the maintenance training is hands-on, skill enhancing, and performance focused instruction. Training is determined complete, as defined by Bell, after each student demonstrates an ability to perform to the course standards for actual maintenance and operation of the equipment referencing technical manuals.

GENERAL INFORMATION

Training Materials and Language: Bell provides each maintenance and pilot training candidate a hard-copy course notebook in the English language for each course conducted by BTA instructor personnel. The training materials will be sufficient to train maintenance technicians and pilots who meet the course prerequisites in the maintenance and operation of the applicable model helicopters. Course instructional electronic media, syllabi, course outlines, and company intellectual property will be considered non-deliverables.

STATE-OF-THE-ART TRAINING RESOURCES

Based at the Bell headquarters in Fort Worth, Texas, the BTA combines a longstanding commitment to excellence and a robust portfolio of industry-leading amenities designed to support professional aviation training.

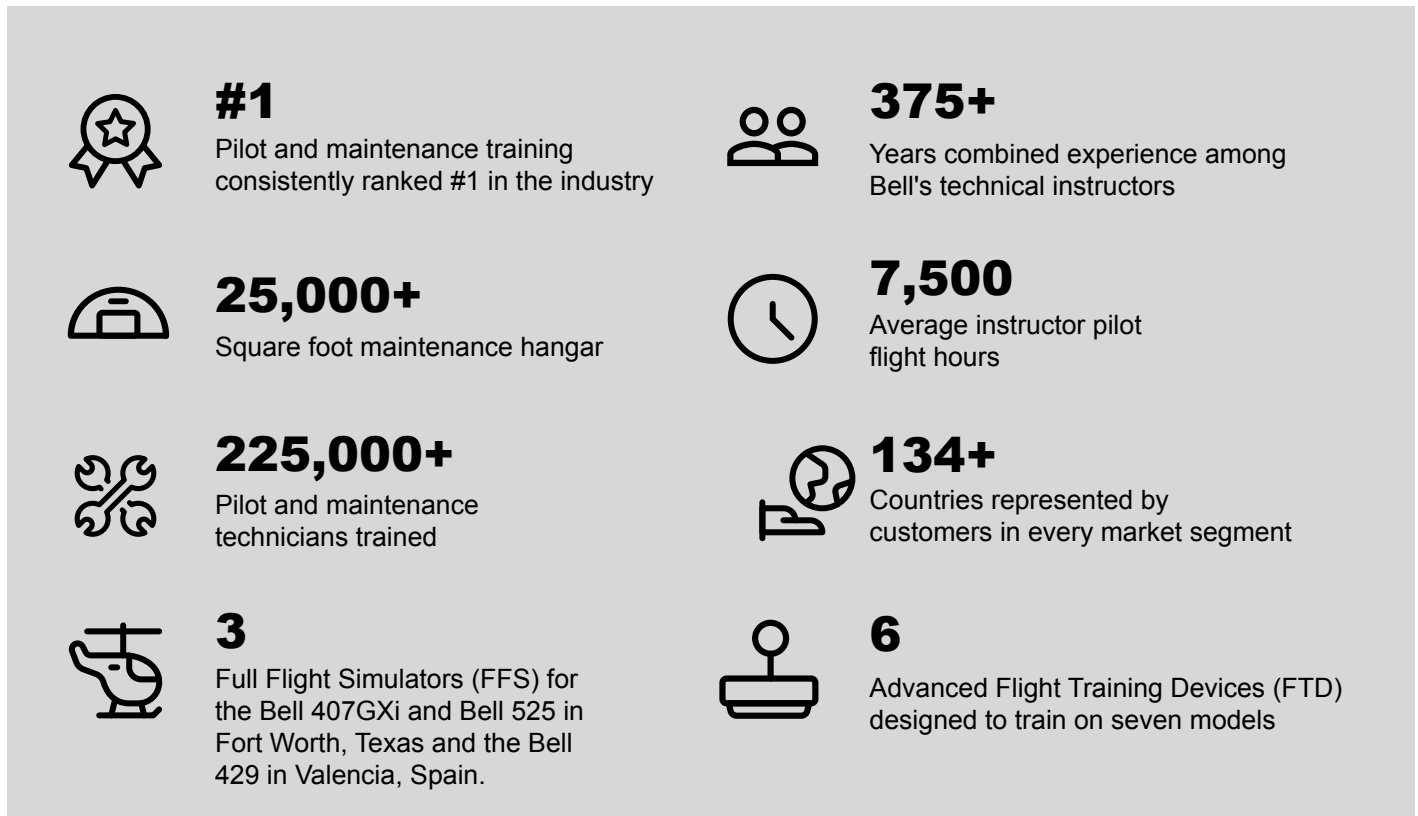

Training Technology: Bell is leading the industry in its use of engineering technology to more effectively teach pilots and maintainers around the world. The use of 3-D, high-fidelity, interactive graphics provide students an authentic representation of each component. Unity courseware allows instructors to manipulate the models to see individual parts and systems in detail without leaving the classroom. This type of training engages students and improves retention.

GLOBAL TRAINING NETWORK

With nearly 70 percent of our commercial aircraft delivered internationally, Bell understands the need for training to be readily available where our customers perform their missions. Our training centers are equipped and certified to meet the needs of our customers around the globe. We are committed to having resources where our customers operate and are investing to provide world-class, global training solutions to meet a growing customer demand.

Recognized by the European Aviation Safety Agency (EASA) as an Approved Training Organization (ATO), the BTA has the authorization to provide Part-FCL type specific flight training courses to EASA regulated customers for the 407, 412, 429, and 505 models, including the use of Flight Training Devices (FTD) for the Bell 407, Bell 429 and 505 models. A Performance Based Navigation (PBN) Generic Non-Type or 412/429 Type Rating Specific courses are also approved.

The BTA is also authorized by various international regulatory agencies for type-specific technical training of engineers / mechanics. These agencies include the Civil Aviation Authority of Singapore (CAAS), Transport Canada (TC), European Aviation Safety Agency (EASA), Australian Civil Aviation Safety Authority (CASA), Civil Aviation Administration of China (CAAC), Director General Civil Aviation of India (DGCA), and the UAE General Civil Aviation Authority (GCAA).

Singapore: BTA Singapore is approved by the Civil Aviation Authority of Singapore (CAAS), European Aviation Safety Agency (EASA), Australian Civil Aviation Safety Authority (CASA), and Director General Civil Aviation of India (DGCA), and the UAE General Civil Aviation Authority (GCAA). BTA Singapore offers regulatory classes for maintenance theory and practical training on all current Bell models and select legacy aircraft. Available courses include avionics maintenance, field maintenance and refresher courses, cable and connector training, and vibration monitoring system training.



Maintenance training at BTA Singapore

Europe: All pilot training classes at BTA – Valencia, are instructed upon the Bell 429 - certified Level D Full Flight Simulator (FFS). The Bell 429 FFS offers the largest standard visual field of view and the largest standard dome radius of any simulator on the market today. Additionally, the FFS offers industry-leading motion performance with high-fidelity superior accelerations, smoothness, and responsiveness powered by REALFEEL® Control Loading System and REALVibe™ Secondary Cueing System.

Training

Student Registration: The customer is responsible for submitting an enrollment request for each training candidate via Bell's on-line registration process at www.bellflight.com/training. It is encouraged that all training be scheduled at contract award to ensure space and instructor availability.

Cancellation Policy: The customer agrees to comply with the BTA cancellation policy as set forth at www.bellflight.com/training.

Trainee Visas: Applying for and receiving a visa for students in a timely manner is the responsibility of the customer. To ensure timely approvals, students must register early.

Trainee Expenses: Arrangements and expenses associated with training, including but not limited to, air travel, ground transportation (car rental/taxi), meals, and lodging for each designated trainee will be the responsibility of the customer.

TRAINING COURSES

The following table summarizes both the pilot and maintenance training course offerings for the Bell 407GX_i, Bell 407GX, and Bell 407. Additional training options are available at bellflight.com/training.

BELL 407GX_i TRAINING COURSE SUMMARY

Course	Duration
Pilot Training	
Bell 407GX _i Ground and Flight Initial	1 week
Bell 407GX _i Ground and Flight Refresher	2 days
Bell 407GX _i Left Seat Orientation for IP	2 days
Bell 407 GX _i NVG Ground and Flight Initial	4 days
Bell 407GX _i NVG Instructor Pilot	3 days
Bell 407GX _i Non-NVG Night Flight	1 flight
407GX/GX _i ATP (FAA Part 142)	3 days
Inadvertant IMC (IIMC) Upset Recovery Course (407GX/GX _i)	1 day
407GX _i Law Enforcement Refresher	2 days
Bell 407GX _i FTD Wet Lease	Per hour
Bell 407GX _i FTD Dry Lease	Per hour
Maintenance Training	
Bell 407GX _i Integrated Avionics System Maintenance	2 weeks
Bell 407GX Training Course Summary	
Bell 407GX Ground and Flight Initial	1 week
Bell 407GX Ground and Flight Refresher	2 days
Bell 407 GX Left Seat Orientation for the IP	2 days
Bell 407GX NVG Ground and Flight Initial	4 days
Bell 407GX NVG Instructor Pilot	3 days
Bell 407GX Non-NVG Night Flight	1 flight
Bell 407GX/GX _i ATP (FAA Part 142)	3 days
Inadvertant IMC (IIMC) Upset Recovery Course (407GX/GX _i)	1 day
Bell 407GX Law Enforcement Refresher	2 days
Bell 407GX FFS Wet Lease	Per hour
Bell 407GX FFS Dry Lease	Per hour

Training

BELL 407GX TRAINING COURSE SUMMARY

Course	Duration
Maintenance Training (407GX)	
407GX Avionics	1 week
Pilot Training (407)	
Bell 407 Ground and Flight Initial	1 week
Bell 407 Ground and Flight Refresher	2 days
Bell 407 Left Seat Orientation for IP	2 days
Bell 407 NVG Ground and Flight Initial	4 days
Bell 407 NVG Instructor Pilot	3 days
Bell 407 Non-NVG Night Flight	1 flight
Inadvertant IMC (IIMC) Upset Recovery Course	1 day
Bell 407 Law Enforcement Refresher	2 days
Bell 407 FTD	2 hours
Maintenance Training (407)	
Bell 407 Component Overhaul	1 week
Bell 407 Field Maintenance (Experienced)	2 weeks
Bell 407 Field Maintenance	3 weeks
Bell 407 B2 Integrated Avionics	3 Weeks
Bell 407 Electrical Maintenance	1 week
Bell 407 B1.3 Field Maintenance	4 weeks

COURSE DESCRIPTIONS

Please visit our website bellflight.com/training for complete course descriptions.





Aeronautical Accessories, a Bell brand, offers more than 4,000 parts and 1,200 unique supplemental type certificates (STCs), allowing you to upgrade your aircraft to meet the latest mission requirements.

With a broad selection of competitively priced, proven replacement parts and accessories, Aeronautical Accessories also features outstanding customer service that has been rated the best in the rotorcraft aftermarket.

INNOVATION, RELIABILITY & PERFORMANCE

Aeronautical Accessories is dedicated to listening to the voice of the customer in developing new products, focusing on the safety for your passengers and crew, and providing an uncompromising emphasis on quality. Our components meet FAA requirements as well as exacting internal standards and are backed by an exceptional warranty—a benefit of being part of Bell. Aeronautical Accessories is also registered under Bell as a certified ISO 9001 with AS9100 Revision D facility.

GLOBAL AVAILABILITY OF PRODUCTS

Through our global distribution and modern inventory management system, we minimize customer downtime for repairs, refurbishments and completions. Whether you are looking for new landing gear components, a specialty window or replacement interior plastic panels, Aeronautical Accessories has these in-demand items as part of our core product offering. We also can assist your needs with the latest developments in safety and mission equipment – featuring several new products that can take your aircraft to that next level. Our options such as enhanced doors and seating can make those long flights seem shorter, and the extensive choices for specialized lighting are sure to assist in all your flights that take place at night. Aeronautical Accessories' growing product line also features important items such as fuel filtration, floats for missions that occur over water, as well as the best solutions available in ground handling equipment.

WE ARE HERE TO HELP

Whether you are customizing your new aircraft, looking to improve your ship's capabilities, or repurposing your helicopter, Aeronautical Accessories is available to assist. Visit our website www.aa.co and learn about all the products we offer. You may also send an email to sales@aero-access.com to reach our Sales & Support team or give them a call at 800.251.7094.



