



# SD-12360

STEEL BATTERY UNIT  
CASE ONLY



## MAIN FEATURES

12 MONTHS WARRANTY

The SD-12360 has a capacity of up to 360W, for 30 minutes duration. This unit requires two top-mounted heads such as the SD-10195 (sold separately), however a wide range of other head types are compatible. It also requires an internal rechargeable battery (sold separately).

### BENEFITS

- 12V
- Suitable for Damp Locations
- ETL performance certified
- 360W Capacity
- 120/347VAC Input

### SPECIFICATIONS

- Housing: 18 Gauge steel housing
- Input Voltage: 120/347VAC 60Hz
- Input Rating: 72W, 600mA/200mA
- Rated Output: 12W
- Battery: Maintenance-free 12V Sealed Lead-acid battery
- Operating Temperature: -10°C to 55°C
- Charging time: 24 hours
- Discharge time: More than 24 hours
- Certifications: ETL performance certified
- Dimension: 334 x 258 x 218 mm (13.15 x 10.16 x 8.6 in)
- Certifications:
  - » ETL performance certified

### MOUNTING

- Top head mounting is standard, side mount is optional

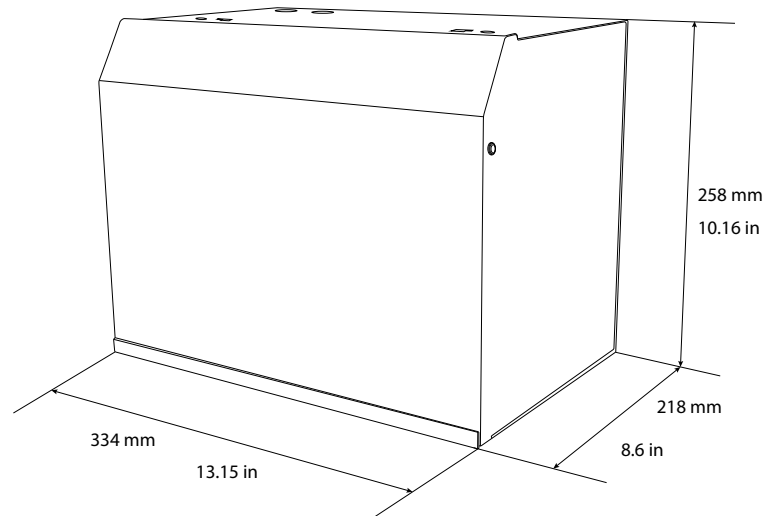

### MECHANICAL

- 120VAC line cord supplied standard
- Universal spider knockout pattern and keyhole mounting slots stamped into back of cabinet
- Multiple conduit entry knockouts

### CIRCUITRY

- Momentary push button test switch
- Diagnostic/pilot LEDs for AC ON and CHARGE
- Fully automatic, current limited charger
- Line latched, low voltage protection
- Solid state design and construction
- Complete battery recharge in 24 hours
- Maintenance free, sealed lead acid battery