

Twistudio

Graphic & Digital Design

PHONE:
+33(0)6.35.25.97.99

WEBSITE:
WWW.TWISTUDIO.FR

INSTAGRAM:
@TWISTUDIO

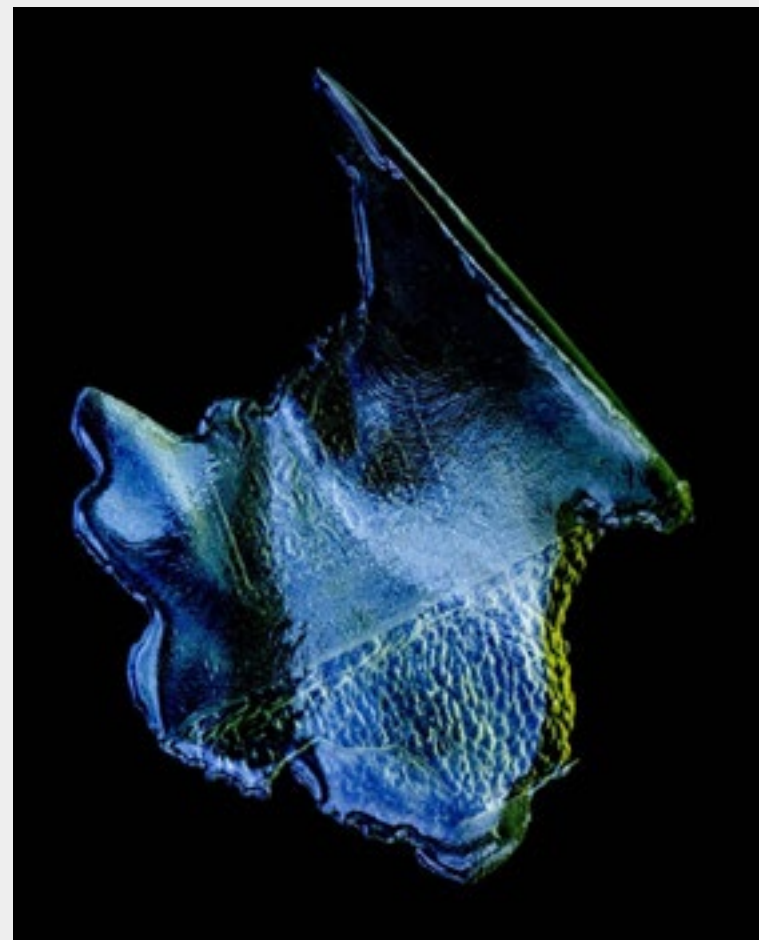

TWISTUDIO

PORTFOLIO

2024

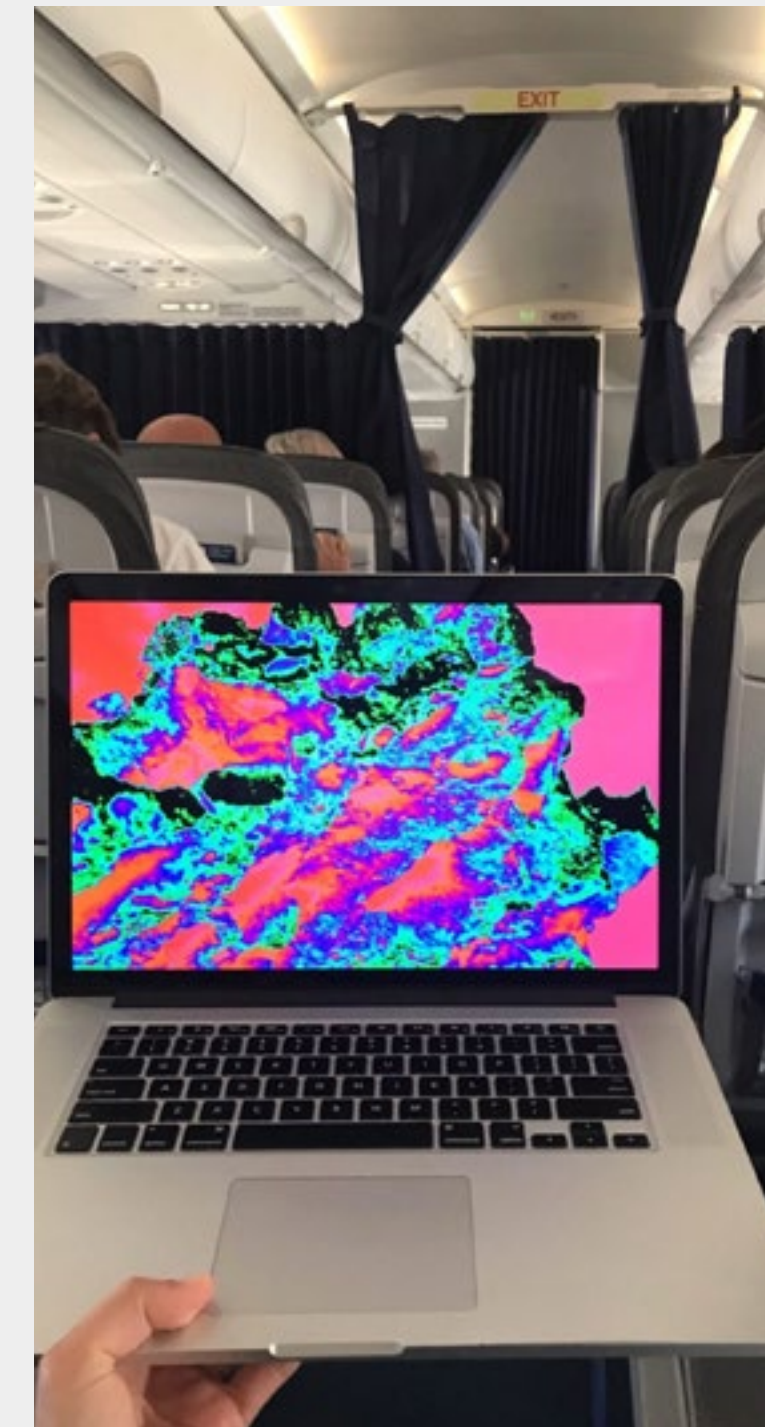
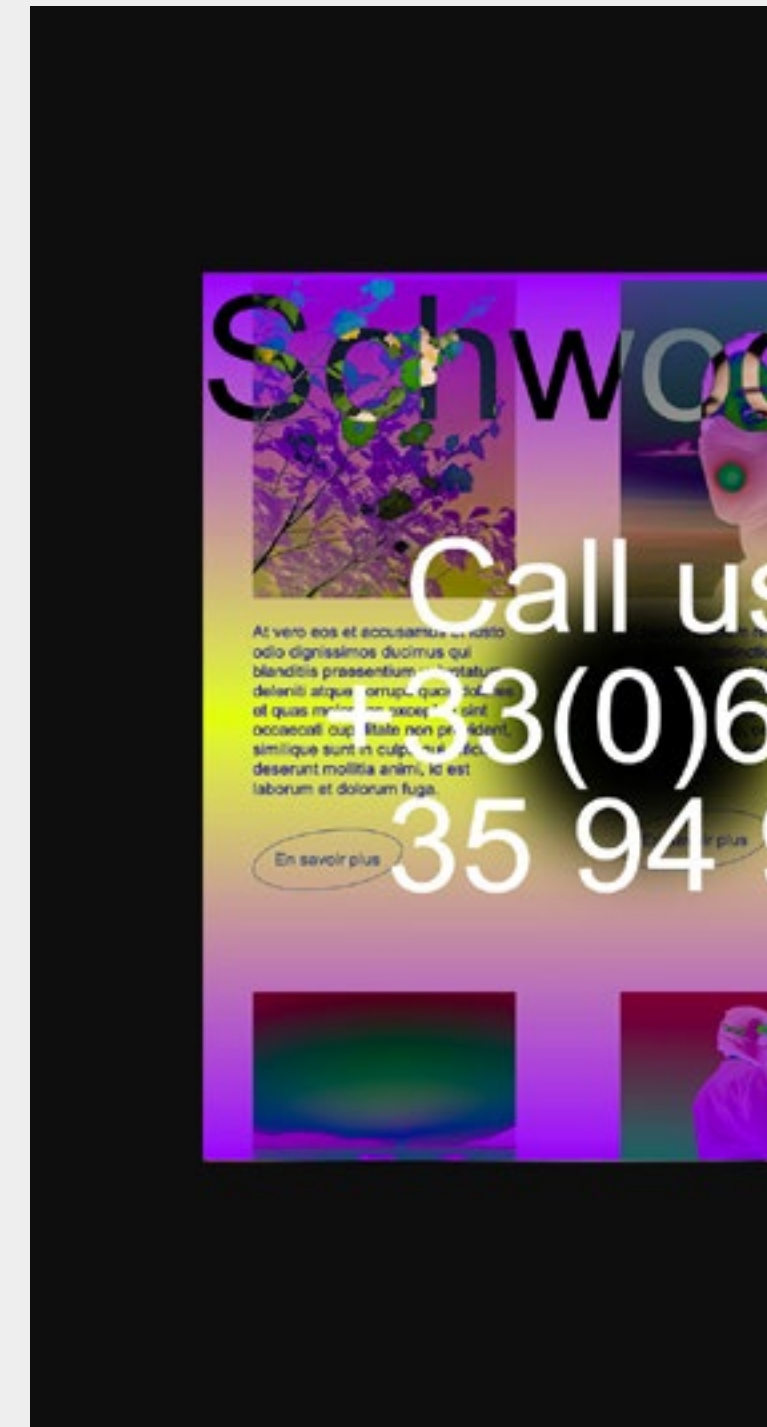

```
-->
/>
(dans l'onglet) -->

= taille du site (aide au responsive) -
content="width=device-width, initial-sca

page (dans google) -->
n" content="Ceci est une description" />

ente dans l'onglet (attention : 32x32 ma
"image/png" href="favicon.png">

lorsque partagée sur les réseaux -->
le" content="Base" />

lorsque partagée sur les réseaux -->
ge" content="http://" />

iption de la page quand reblogguée sur t
rd" content="summary" />
tle" content="Base" />
age" content="http://" />
scription" content="" />

ss (pour remettre à zéro l'apparence de
type="text/css" href="css/reset.css" />

s (mon CSS) -->
type="text/css" href="css/main.css" />
-->
```

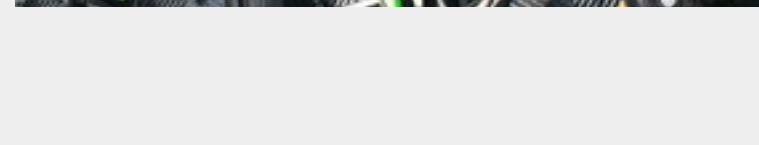
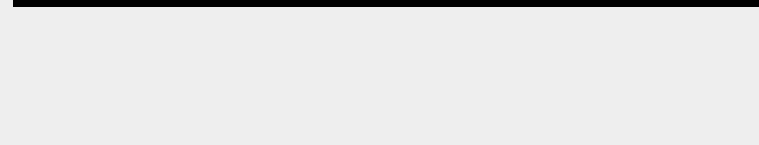
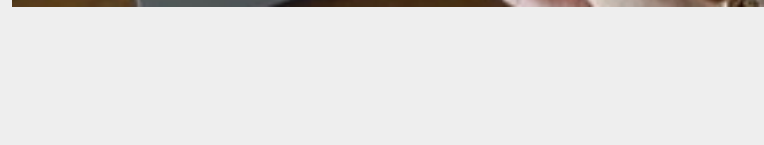

at-paris

GO TO WEBSITE

AGENCY PORTFOLIO

WEBDESIGN + CODING (WEBFLOW) +
MAINTENANCE 2023 - 2024



Works

About

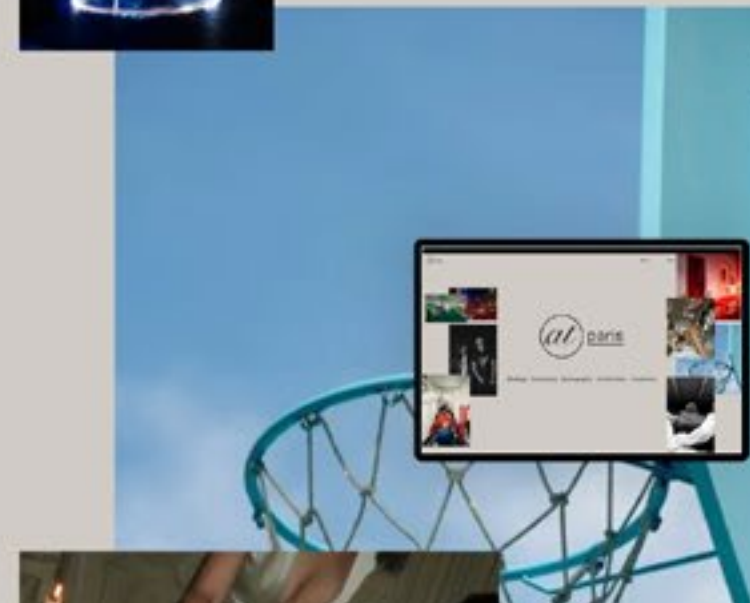
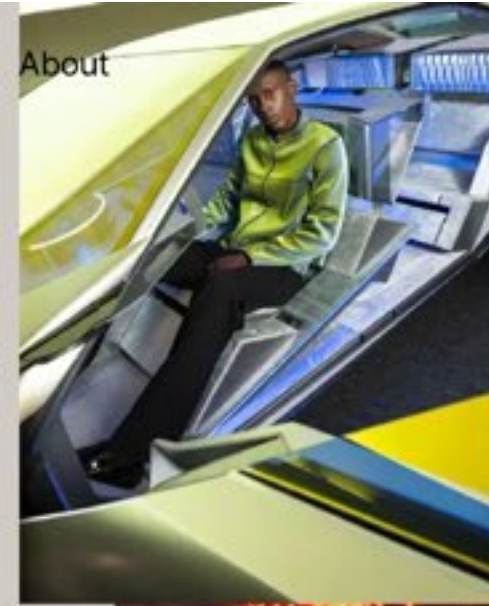

Strategy - Consulting - Scenography - Art Direction - Production



NEW

Havana Club 2023

NEW

Cédric Grolet x Arsham

NEW

Anna RVR 

NEW

21Savage

Usher - My Way Club

3.Paradis - SS24

Peugeot

Lacoste

3 Paradis - SS23 Women

at-paris

GO TO WEBSITE

AGENCY PORTFOLIO

WEBDESIGN + CODING (WEBFLOW) + 2023 - 2024
MAINTENANCE

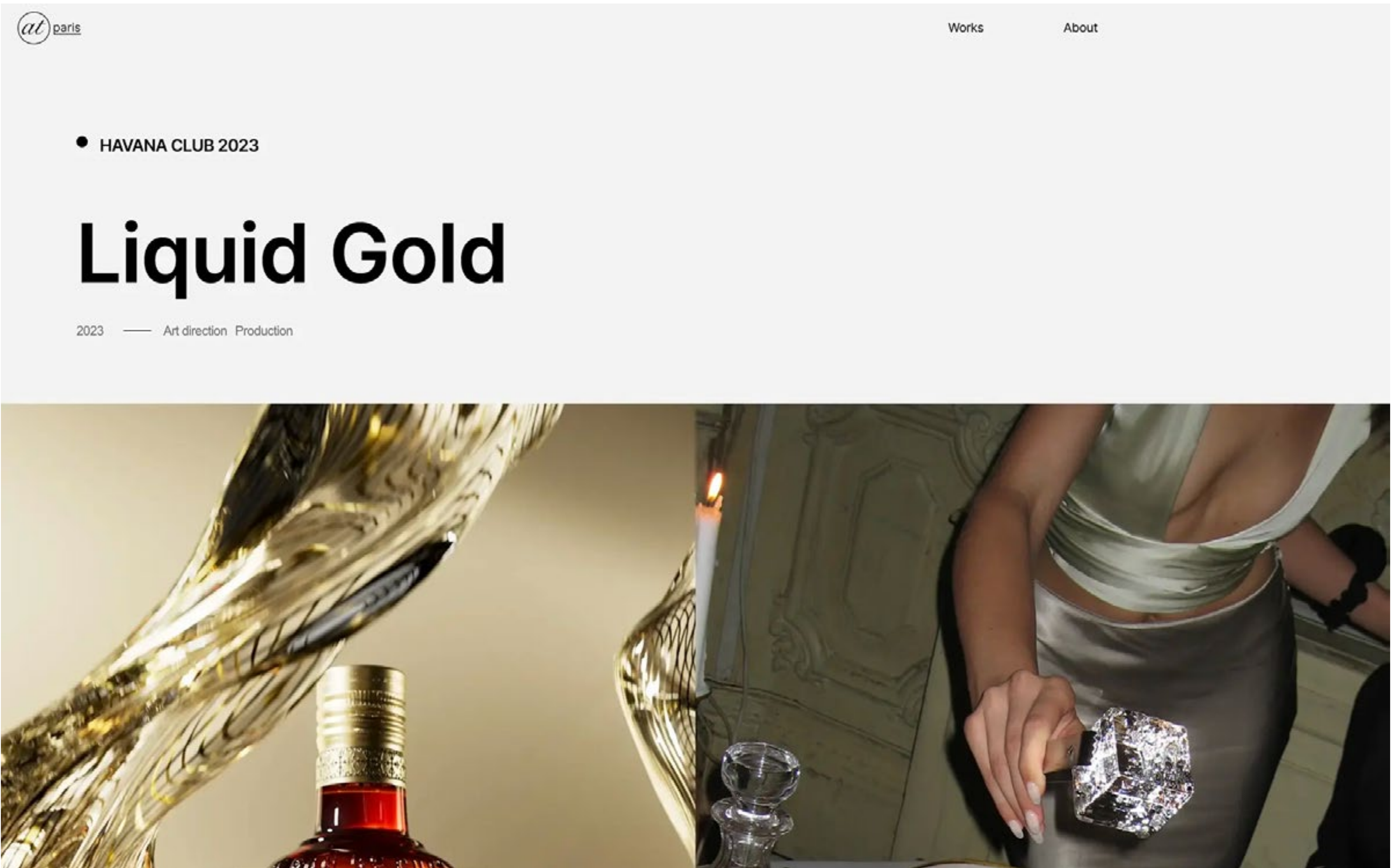

CLIENT
Anna RVR

OUR ROLE(S)
Set design
Scenography



NEXT

21Savage ↗

Sabrina Lucas

ART GALLERY

LOGO + ART DIRECTION

2022



Sabrina Lucas

ART GALLERY

LOGO + ART DIRECTION

2022



Que La Famille - PNL

STREETWEAR E-SHOP

WEBDESIGN + CODING (SHOPIFY)

2020

0 QUE LA FAMILLE Catalogue Look Book Mon compte



Doudoune Puffy grise avec écriture Que La Famille sérigraphiée sur le devant. Détail coeur sérigraphié dans le col. Modèle différent de l'exemplaire posté sur les réseaux.

Composition
100% Polyester

Taille
Le mannequin mesure 1m84 et porte du M.

Livraisons et remboursements
Nous livrons partout dans le monde. Si votre commande ne vous convient pas, voir les conditions.

Doudoune puffy CL Grise
150,00 €

[Guide des tailles](#)

XS - 1 +

Ajouter au panier



Que La Famille - PNL

STREETWEAR E-SHOP

WEBDESIGN + CODING (SHOPIFY)

2020

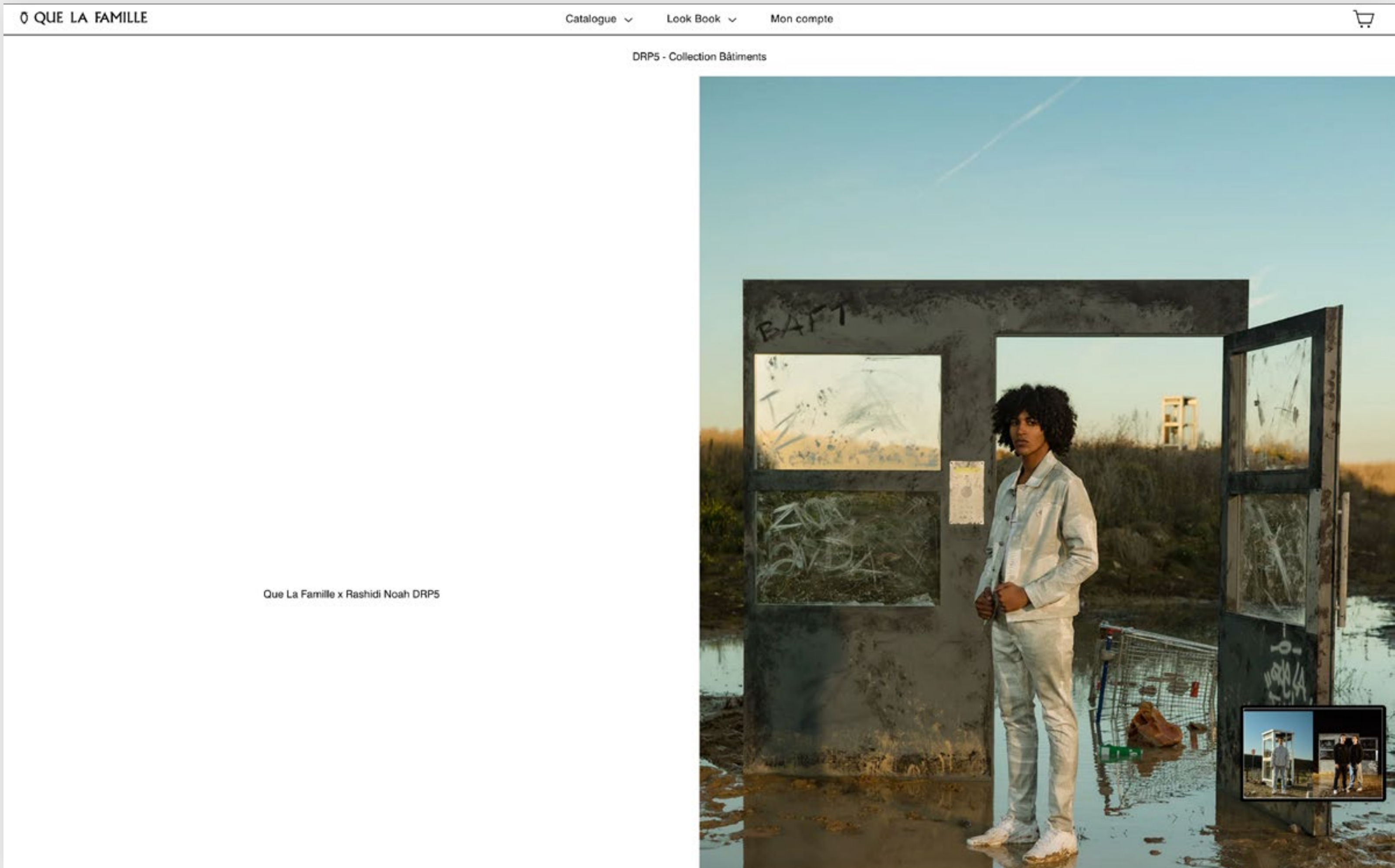

Witched

GO TO WEBSITE

ONLINE PERSONAL GALLERY

WEBDESIGN + CODING (WEBFLOW) + 2024
CONTENT CREATION (AI ASSISTED)

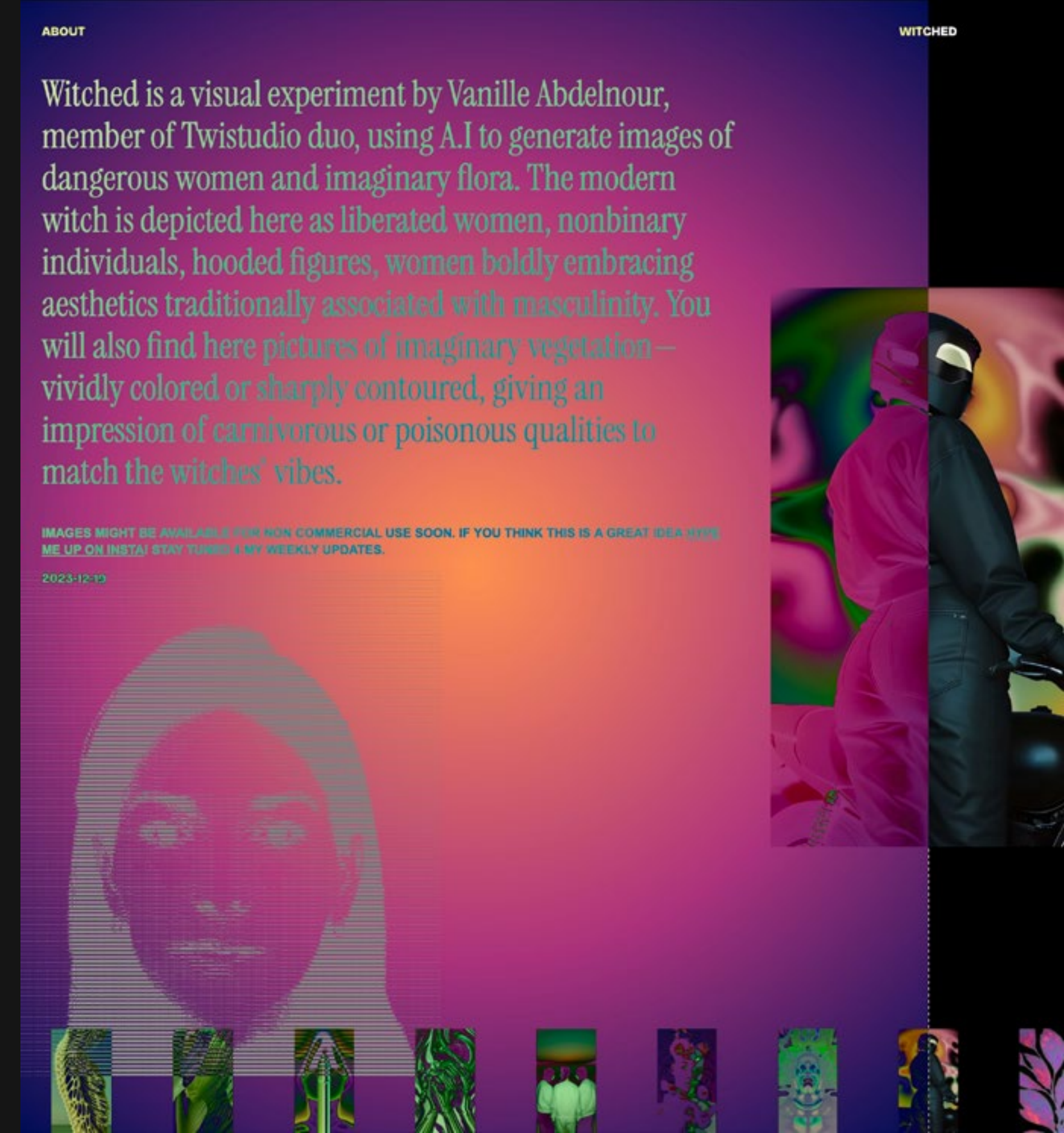

Witched

[GO TO WEBSITE](#)

ONLINE PERSONAL GALLERY

CONTENTCREATION-AIXHUMANCOL-
LABORATION 2024

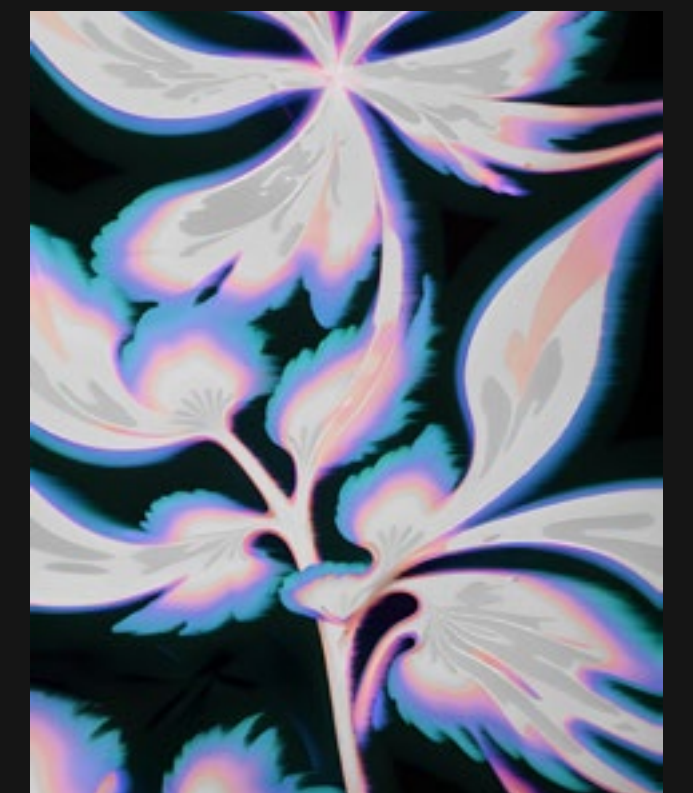
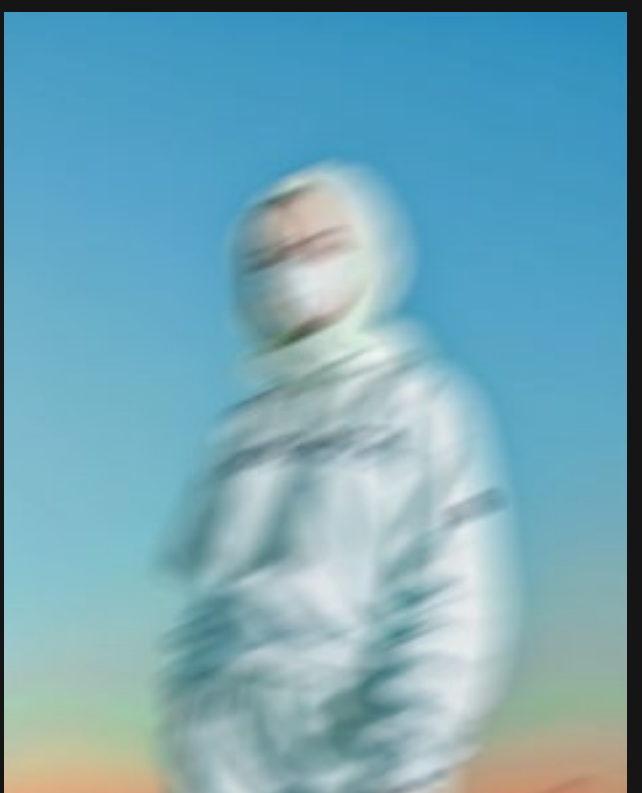
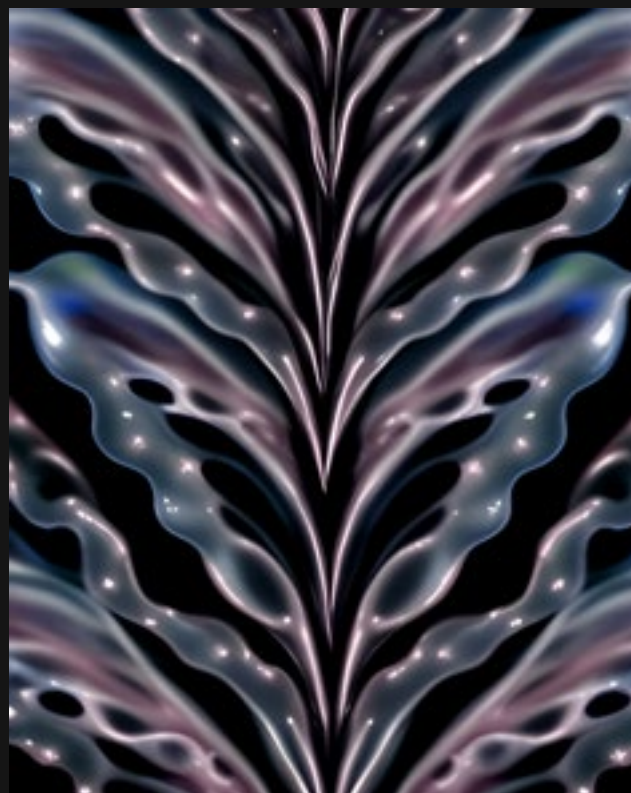
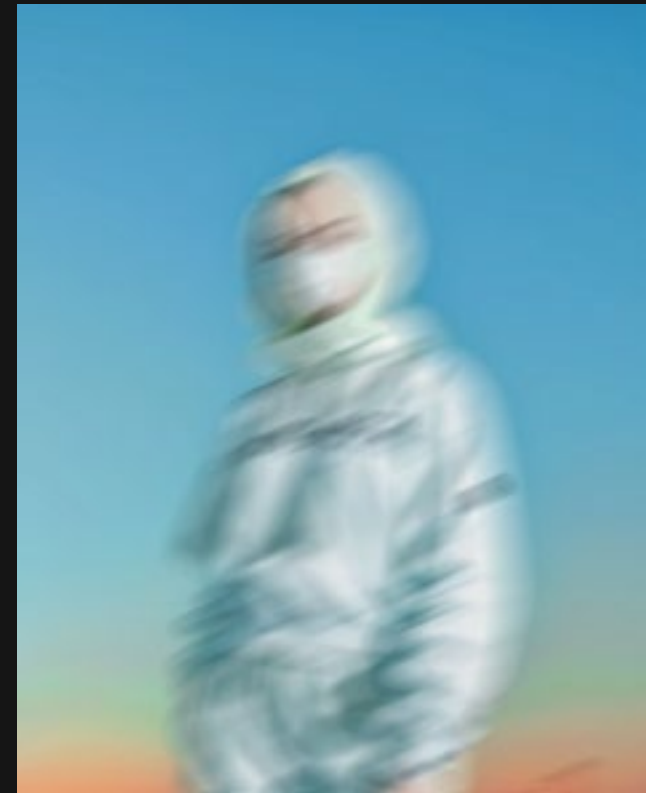
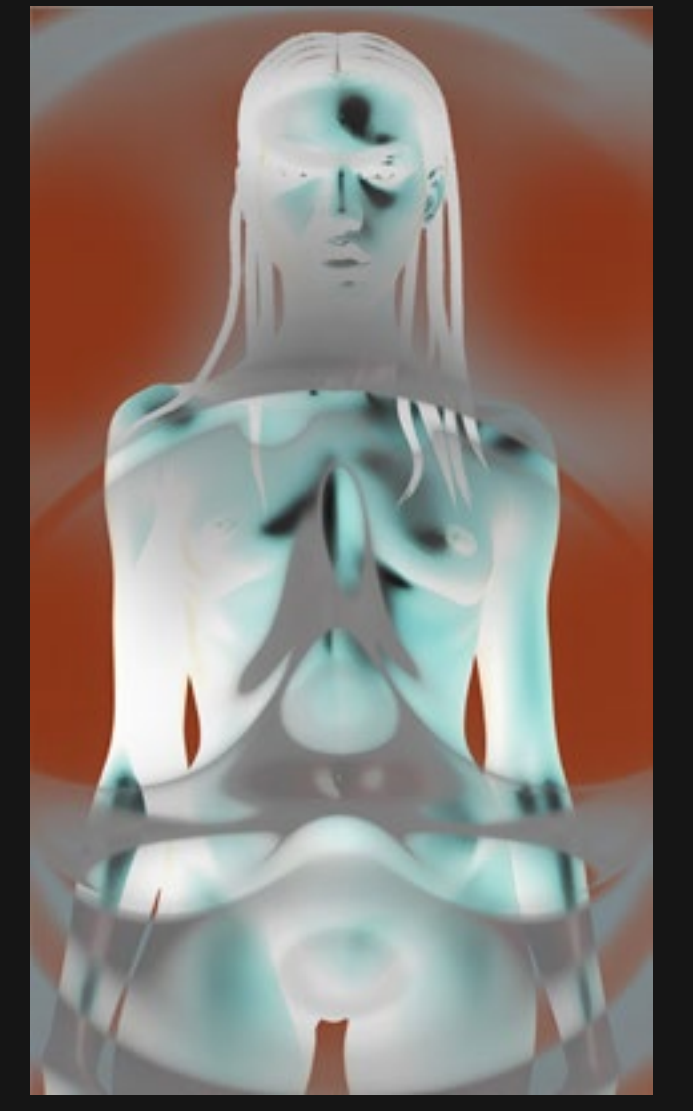
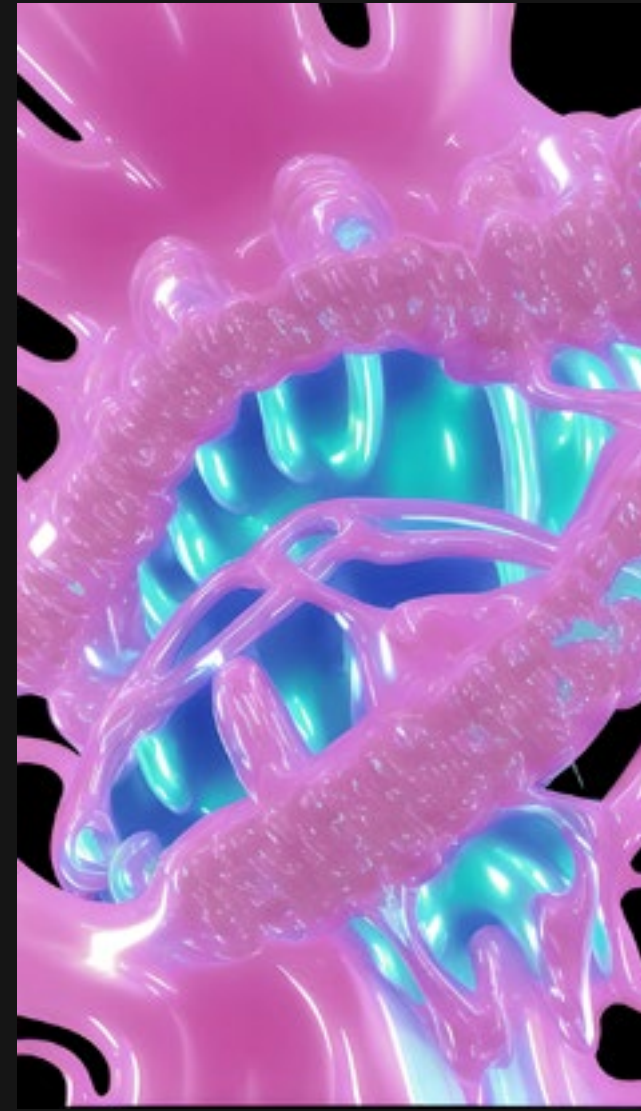
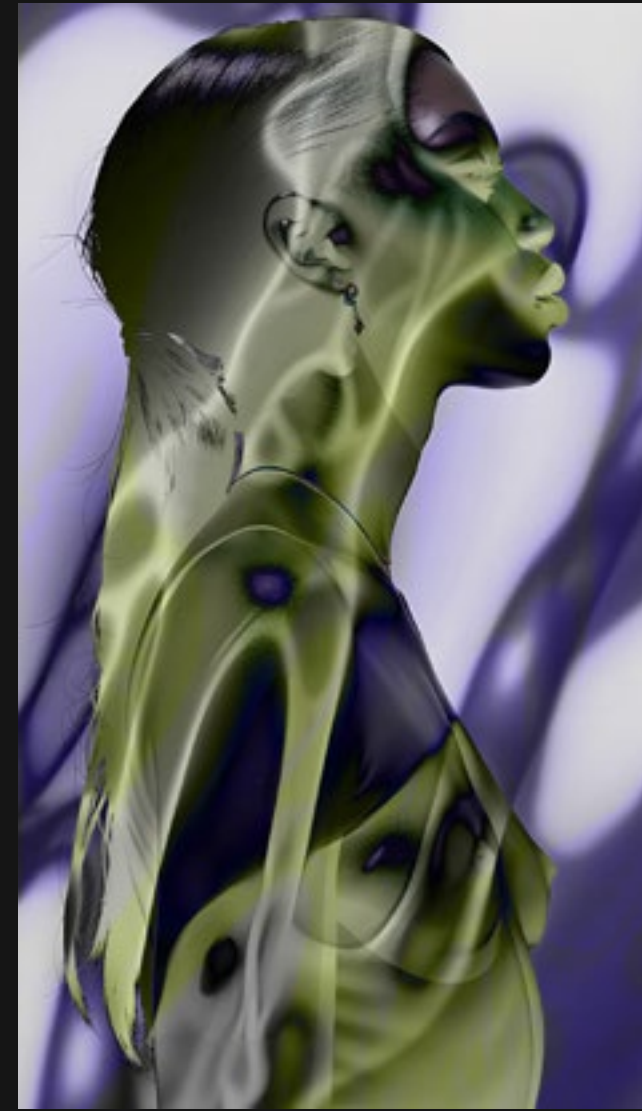
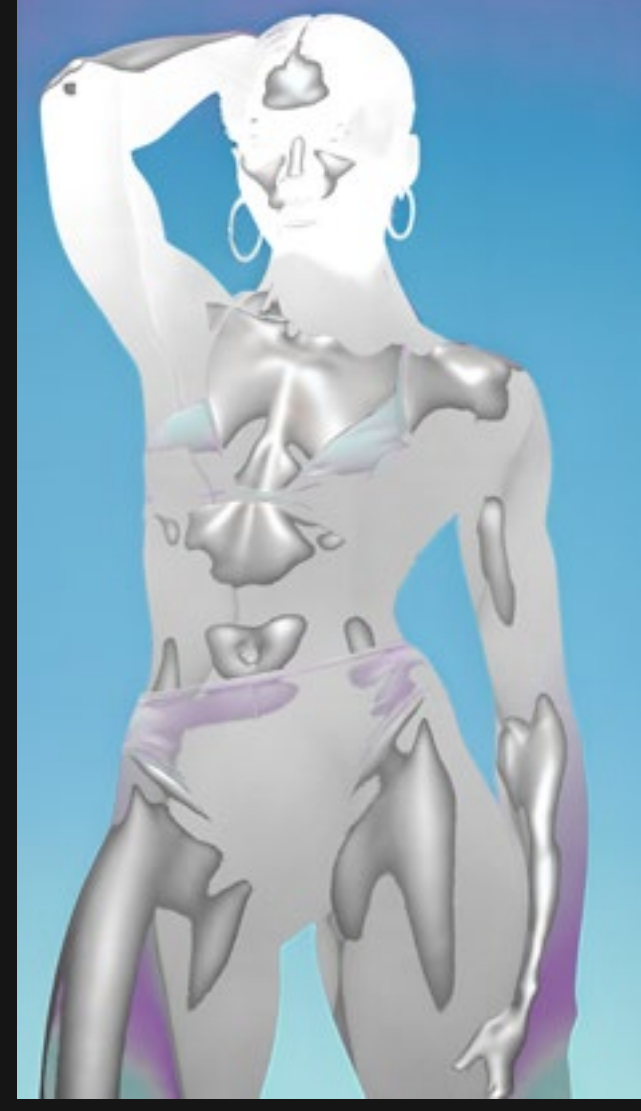

Ekonoo

DIGITAL SAVING MANAGEMENT

BRANDING + CUSTOM TYPE

2021

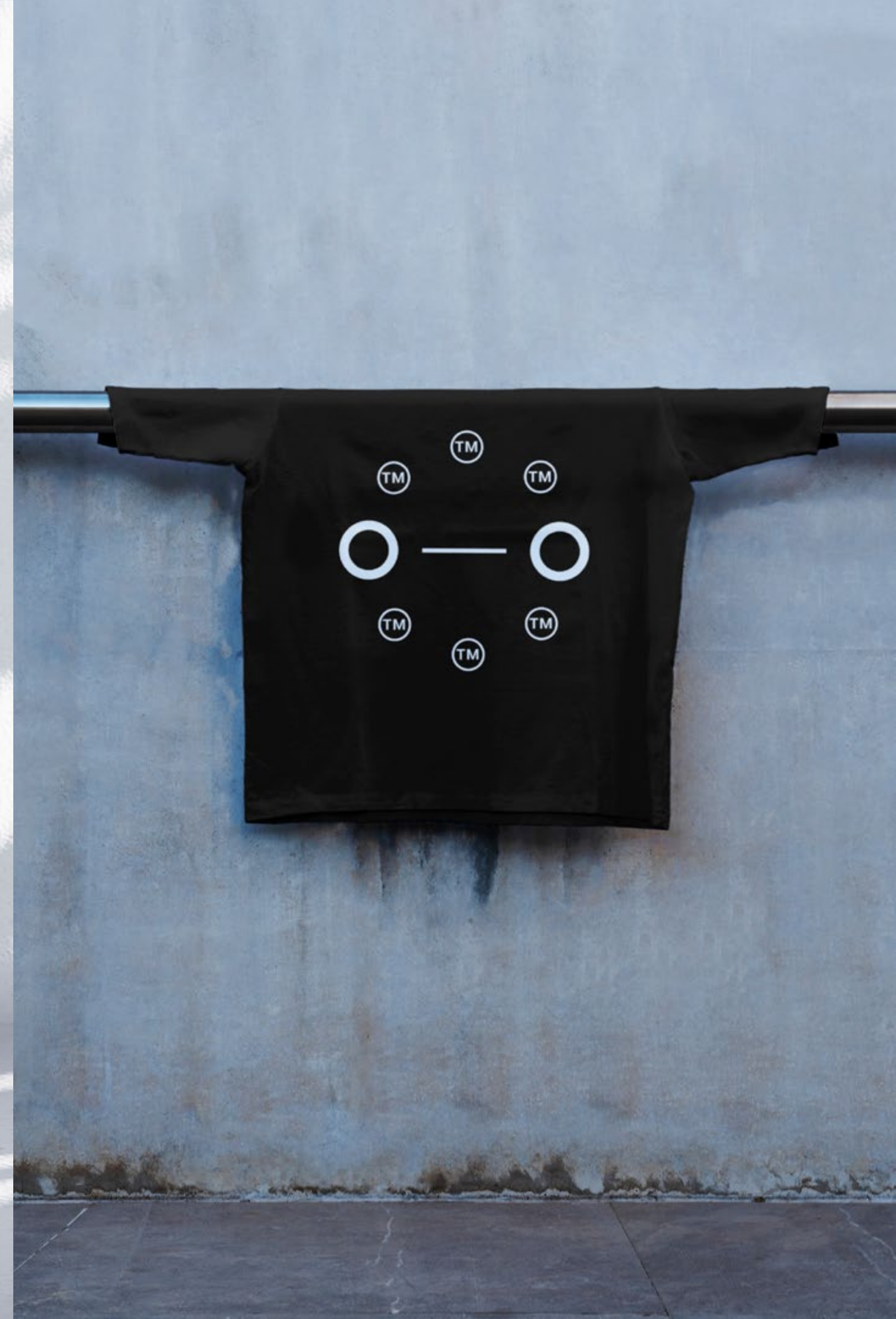

Ekonoo

DIGITAL SAVING MANAGEMENT

BRANDING + CUSTOM TYPE

2021

ekonoo

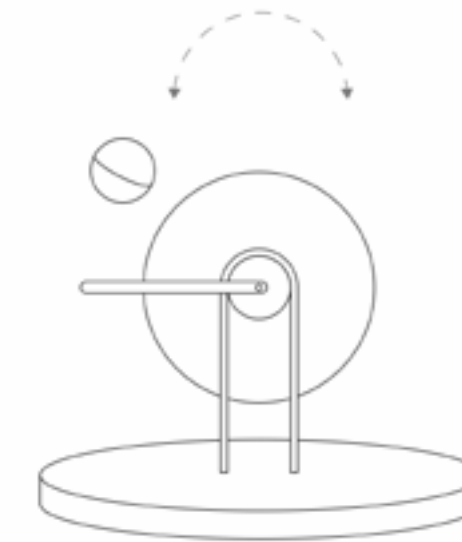
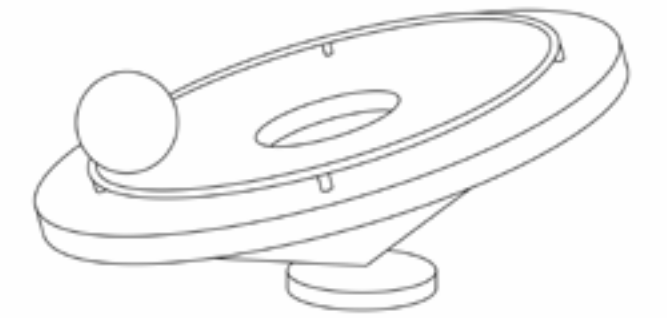
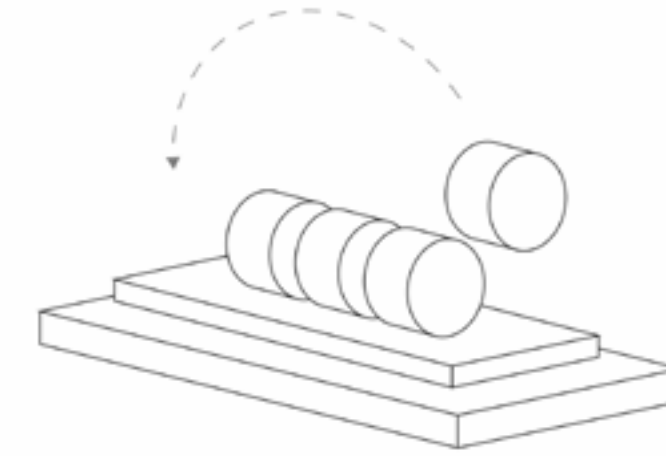
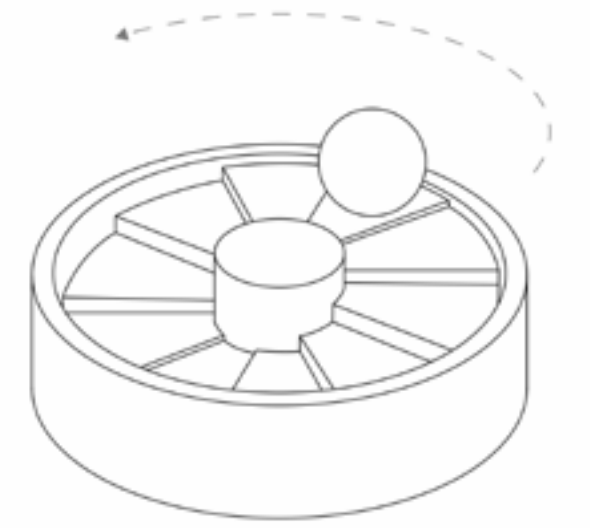
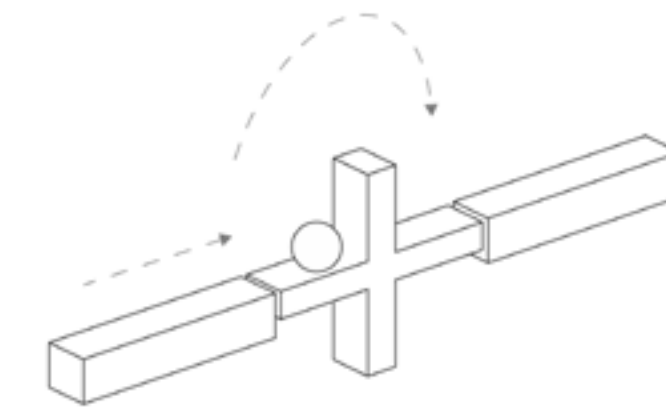

ANIMATIONS CIRCULAIRES PLANCHIE 1

ekonooTM

Typelab

FOUNDRY E-SHOP

WEBDESIGN + CODING (SHOPIFY)

2018-2021

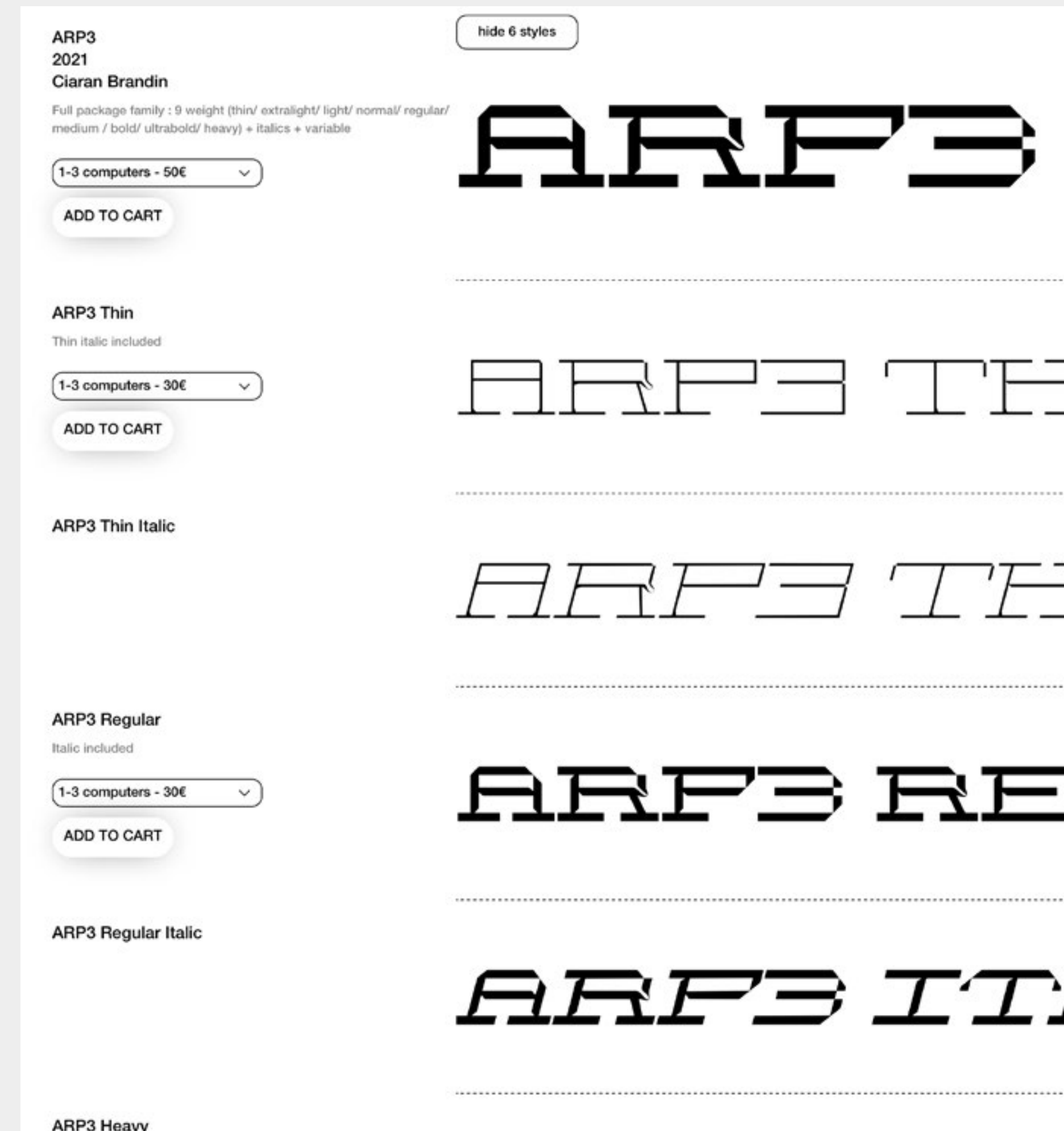
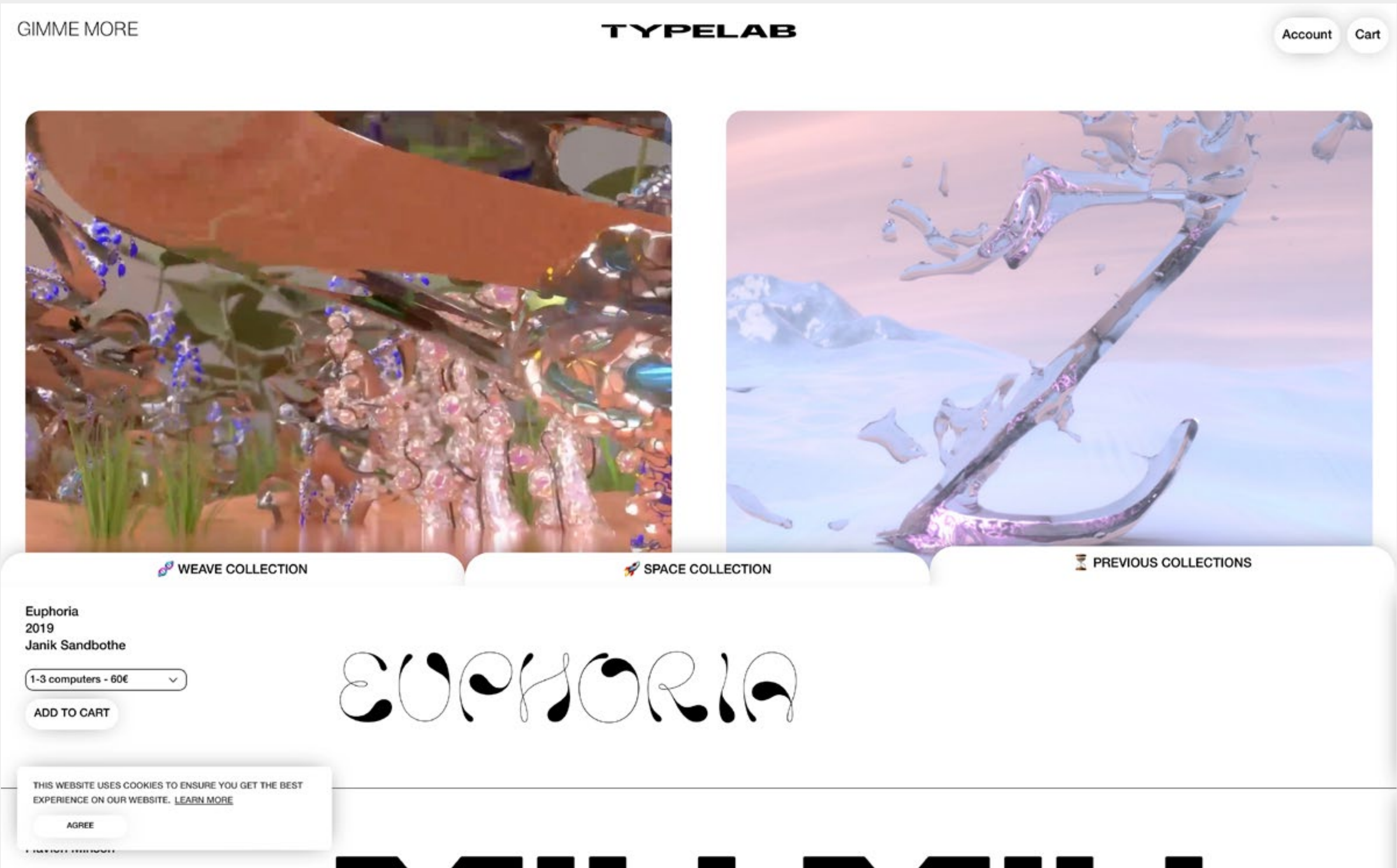

Charlie Spencer

ARTIST - SCULPTOR

PHOTOGRAPHY + EDITING

2023

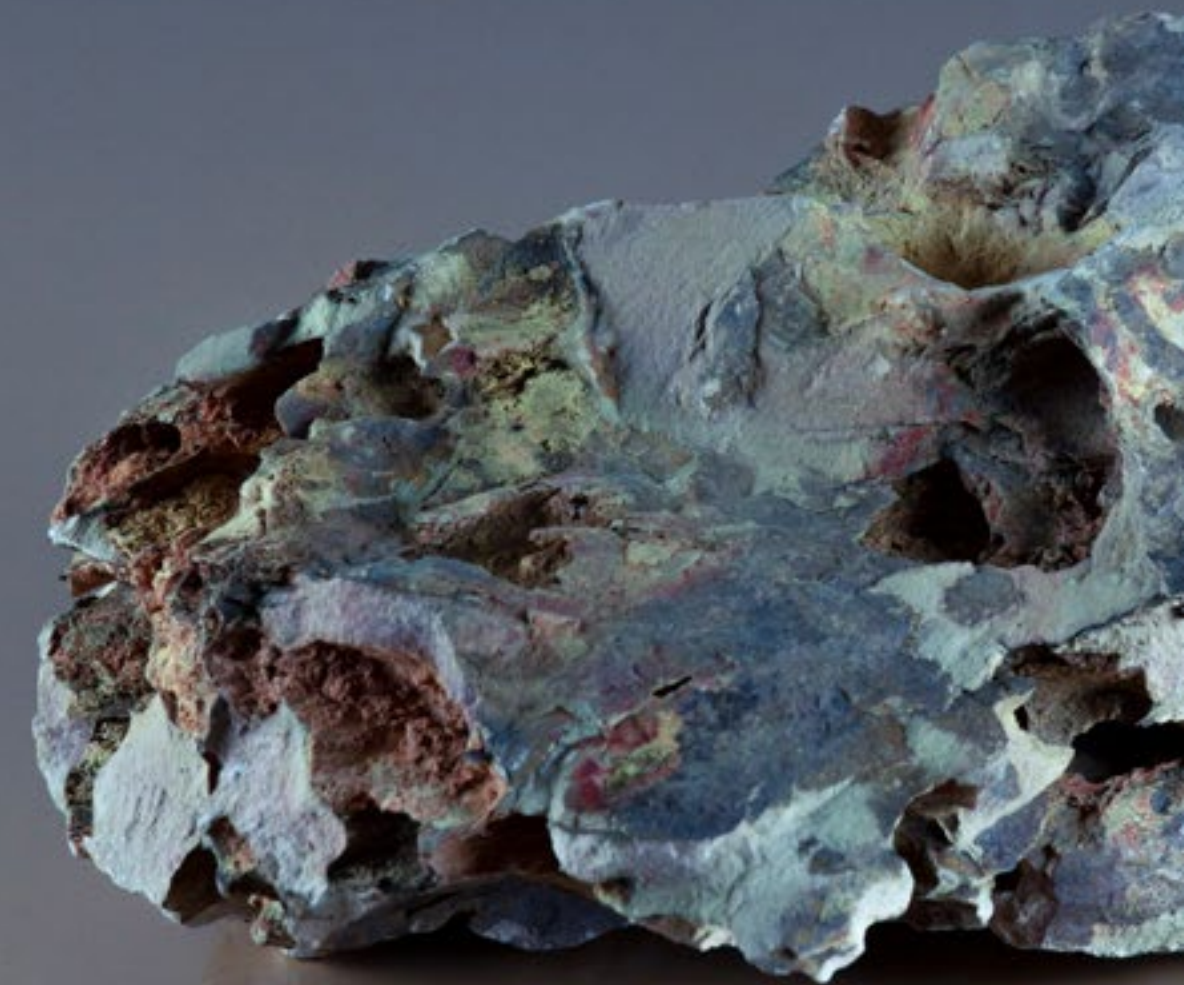

Charlie Spencer

ARTIST - SCULPTOR

PHOTOGRAPHY + EDITING

2023

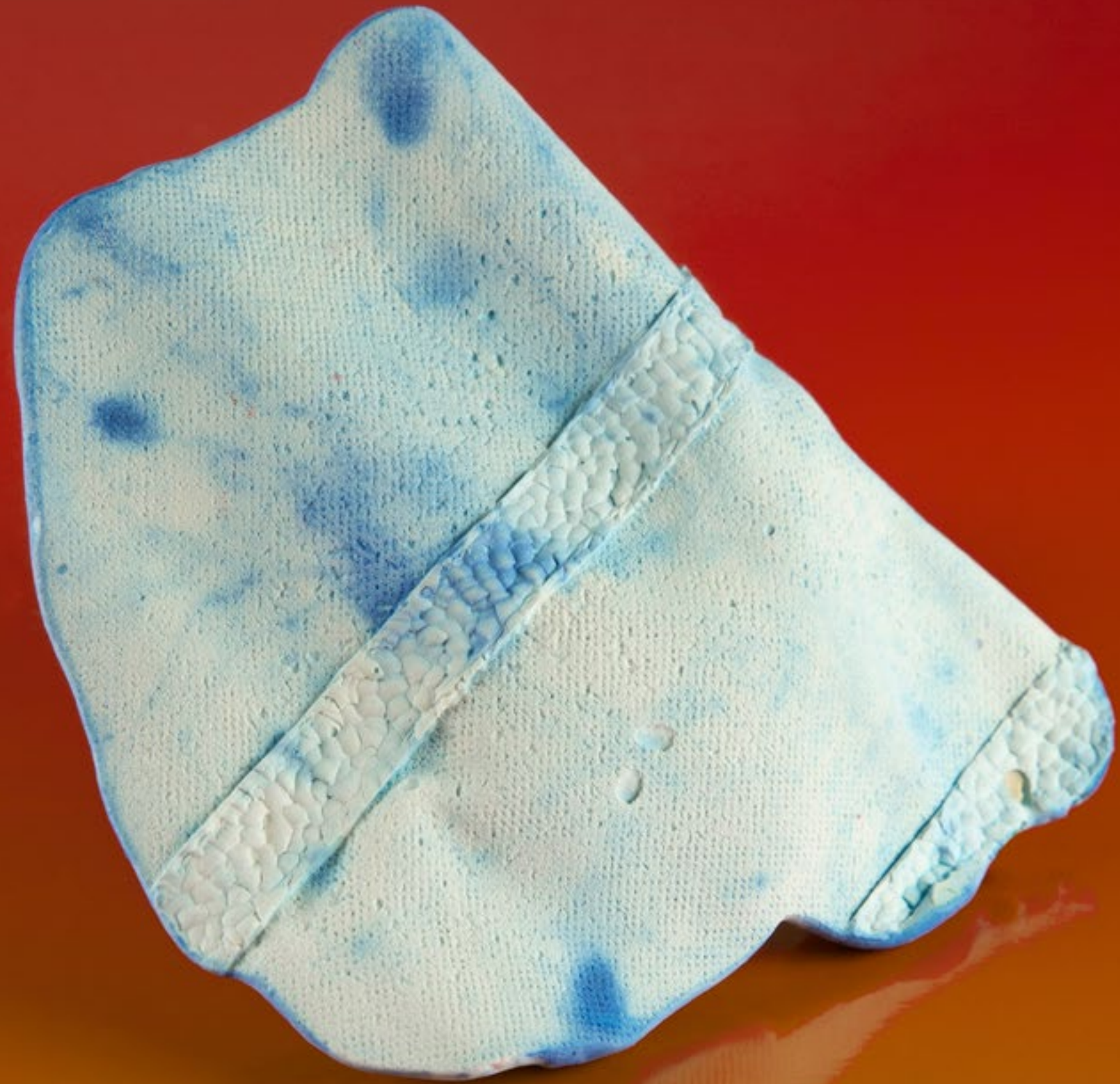

3.Paradis

GO TO WEBSITE

LUXURY E-SHOP

WEBDESIGN + CODING (SHOPIFY) + 2024
MAINTENANCE

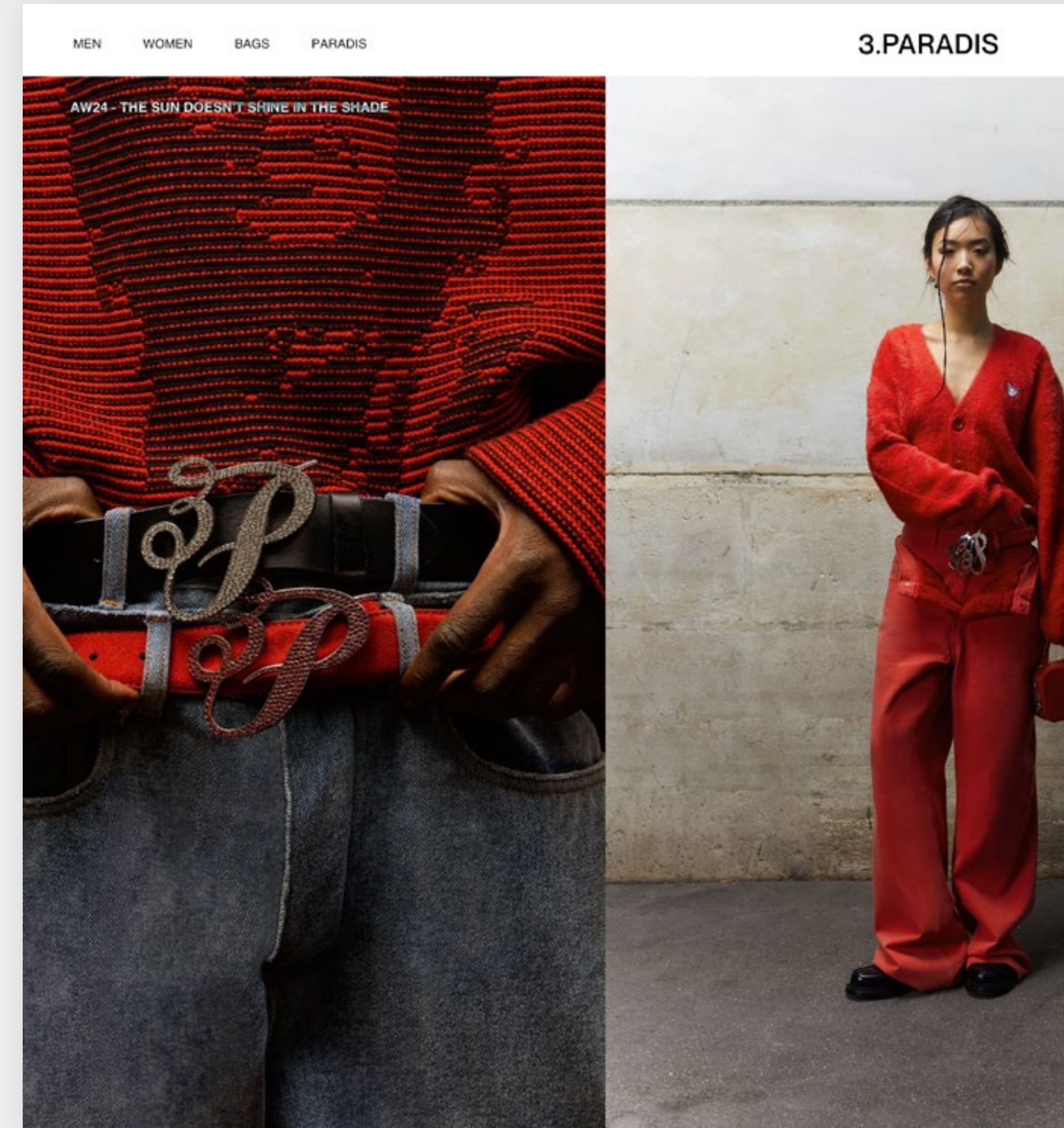

3.Paradis

GO TO WEBSITE

LUXURY E-SHOP

WEBDESIGN + CODING (SHOPIFY) +
MAINTENANCE 2024

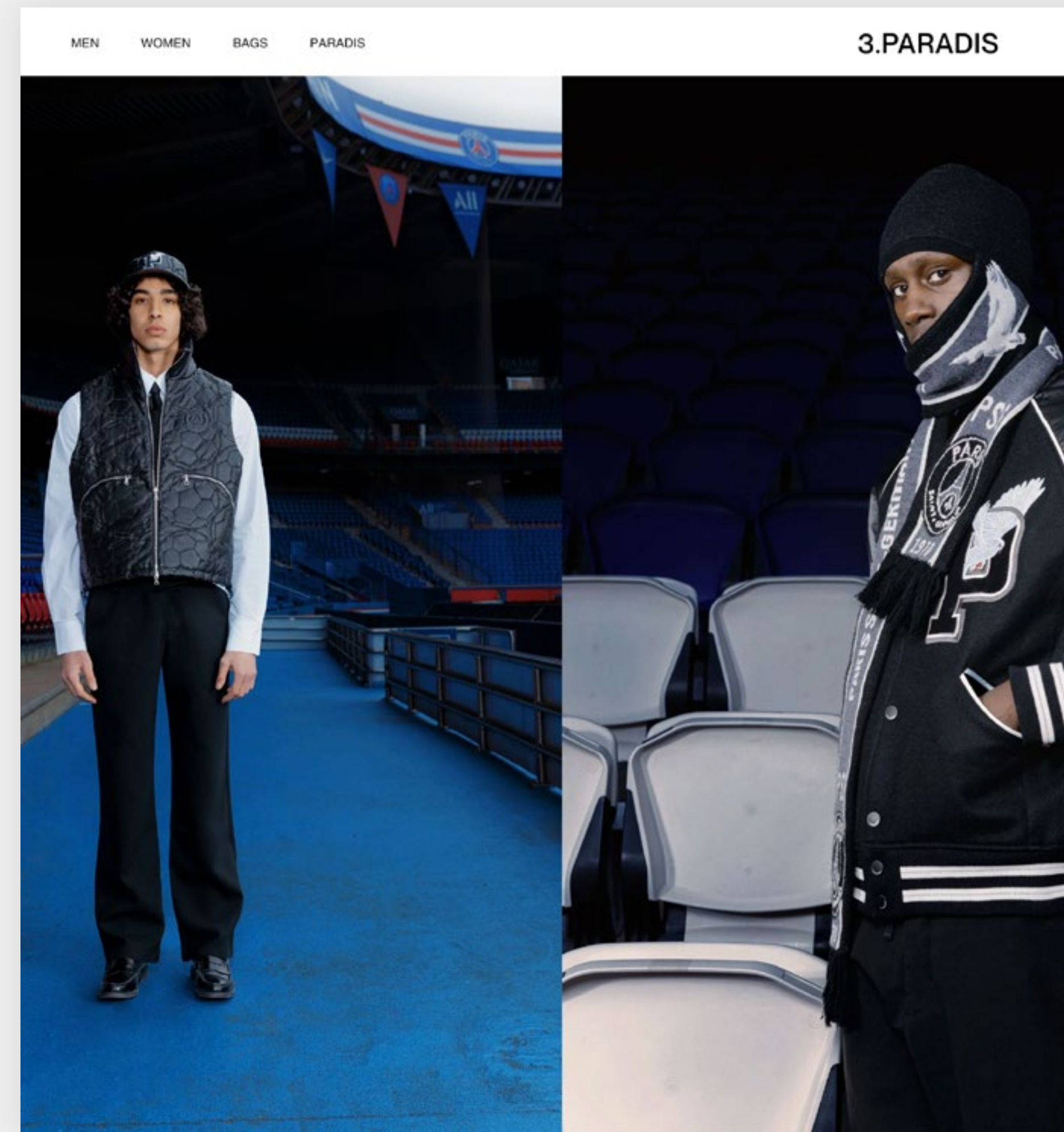
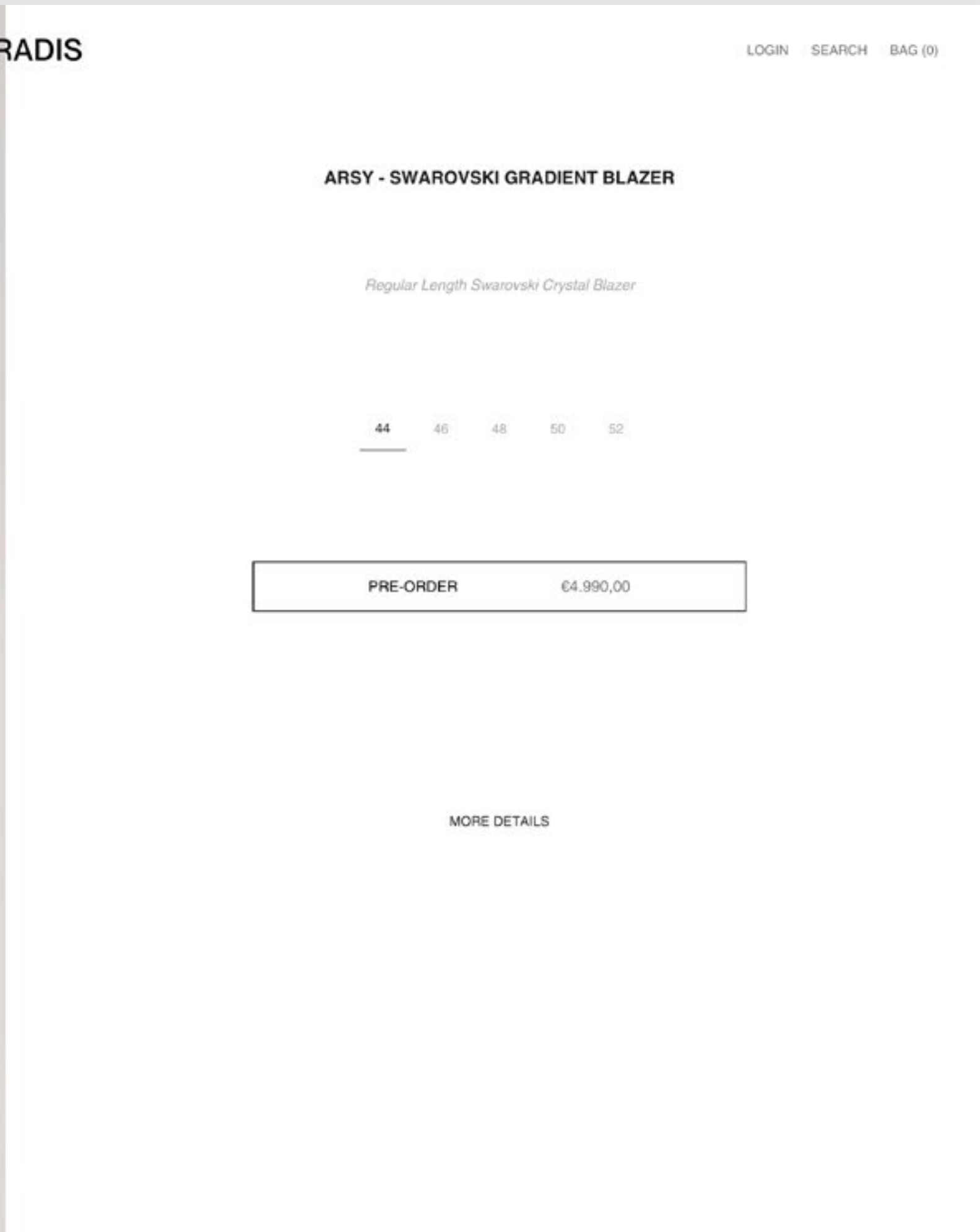

Noise

MENTAL HEALTH MAGAZINE

WEBDESIGN W/ FLORIANE
ROUSSELOT + CODING (SHOPIFY)

2022

GIMME MORE [ALL](#) [CONFIDENCE](#) [CREATIVITY](#) [FREELANCING](#) [IMPOSTER SYNDROME](#) [MENTAL HEALTH](#) [MONEY ISSUES](#) [Ressources](#)

NOISE

A MENTAL-HEALTH-FIRST APPROACH TO CREATIVE ADVICE AND DISCUSSION

[Interview](#) [MENTAL HEALTH](#)



WITH ERIC HU

MENTAL HEALTH, SELF-CARE & MAINTAINING A HEALTHY PRACTICE WITH ERIC HU

[Interview](#) [CREATIVITY](#)



CREATIVE WITH ANALEOVY INSPIRATION

ANALEOVY : A CONVERSATION ON CREATIVE INSPIRATION

[Interview](#) [MONEY ISSUES](#)



MONEY WITH PORTO ROCHA MONEY

PORTO ROCHA: TRANSITION FROM FREELANCING TO FOUNDING, PRICING PROJECTS & FINANCIAL ANXIETY

[Article](#) [FREELANCING](#)



HOW DO WE DEAL WITH OUR INNER NOISE AS CREATIVE S...

[BACK](#) 

14/01/2022 [FREELANCING](#) [@ANALEOVY](#) INTERVIEW BY HARRY BENNETT

“I TRY NOT TO THINK TOO MUCH AND JUST FOLLOW MY GUT”: ANALEO PERNAFARRATE ON CREATIVE INSPIRATION, THE BEAUTY OF THE MUNDANE AND SOCIAL-MEDIA-DISPOSABILITY

Whether it's a smiley face in the left-over crusts of half-eaten toast, an obscure animal spilling at the pages with pencil lead, Mexico-City-based painter Analoevy Pereznafarrate producing a prolific body of work, with each piece – big or small – as captiv

Fundamentally studying the sociability, presence, physical form and – crucially – the be place, there is a poetry, sensitivity and serenity to Analoevy's work. A reflective eclectic made all the more powerful through the thematically contrasting audacity of its mark-mak of their subjects, the materials it utilises, and the very st

SPEAKING TO US AT NOISE, ANALEOVY TALKS ABOUT FINDING INSPIRATION IN BOTH THE WORLD YOU AS WELL AS WITHIN YOURSELF, THE FRUSTRATION OF APPEALING TO A WIDE COMMERCIAL AUDIENCE, AND HER DISLIKE OF THE TERM 'ARTIST'.

Noise

MENTAL HEALTH MAGAZINE

WEBDESIGN W/ FLORIANE
ROUSSELOT + CODING (SHOPIFY)

2022

BACK

● DIVERSITY & INCLUSIVITY

Black Beyond
BLM SHOP

Black Blossoms
BLM EDUCATION

Black Creativity Matters
can push for real change
BLM DIVERSITY

Black London Creatives
BLM DIVERSITY

Black Mental Health Matters
BLM MENTAL HEALTH

Commercial Break

● INNER NOISE

Dare to be open, dare to be sensitive: how to shape the conversation around creative mental health
MENTAL HEALTH

Failure Does Not Define You
CONFIDENCE

Graphic Support Group Podcast
MENTAL HEALTH PODCAST

Hey Cool Job
CONFIDENCE PODCAST CREATIVITY

Mind UK
MENTAL HEALTH GET HELP

● BUSINESS & MONEY

Design Interns Club
MONEY INTERNSHIPS

Experienced freelancer for anyone going it alone
FREELANCING TIPS

How to reset your client relationships
MENTAL HEALTH FREELANCING TIPS

On Design Podcast
MENTAL HEALTH SOCIAL NETWORKS TIPS

The Experience Vortex
MONEY INTERNSHIPS

The MITM podcast

Mental Health Confidence Money Freelancing Diversity Feminism

BACK

● BUSINESS & MONEY

Design Interns Club
MONEY INTERNSHIPS

Experienced freelancer for anyone going it alone
FREELANCING TIPS

How to reset your client relationships
MENTAL HEALTH FREELANCING TIPS

On Design Podcast
MENTAL HEALTH SOCIAL NETWORKS TIPS

The Experience Vortex
MONEY INTERNSHIPS

The MITM podcast

14/01/2022 FREELANCING @ANALEOVY INTERVIEW BY HARRY BENNETT

“I TRY NOT TO THINK TOO MUCH AND JUST FOLLOW MY GUT”: ANALEOVY

Noyce Club

CREATIVES CLUB PROJECT - 1 PAGE WEBDESIGN + CODING (WEBFLOW) 2023

NOYCE

THE CONCEPT

PRICING

EARLY ACCESS

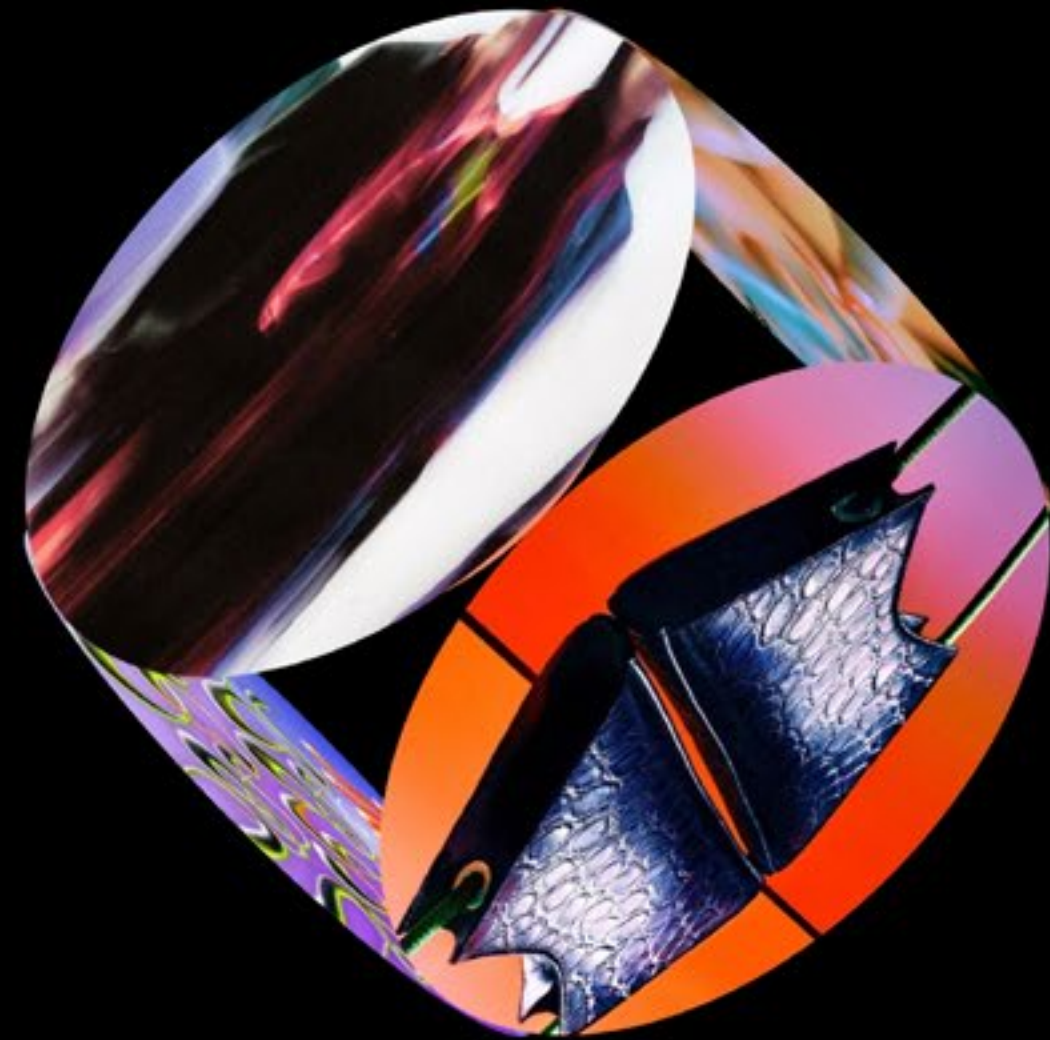

HOUSE OF CREATIVES CURATED BY FLORIANE ROUSSELOT

EARLY ACCESS

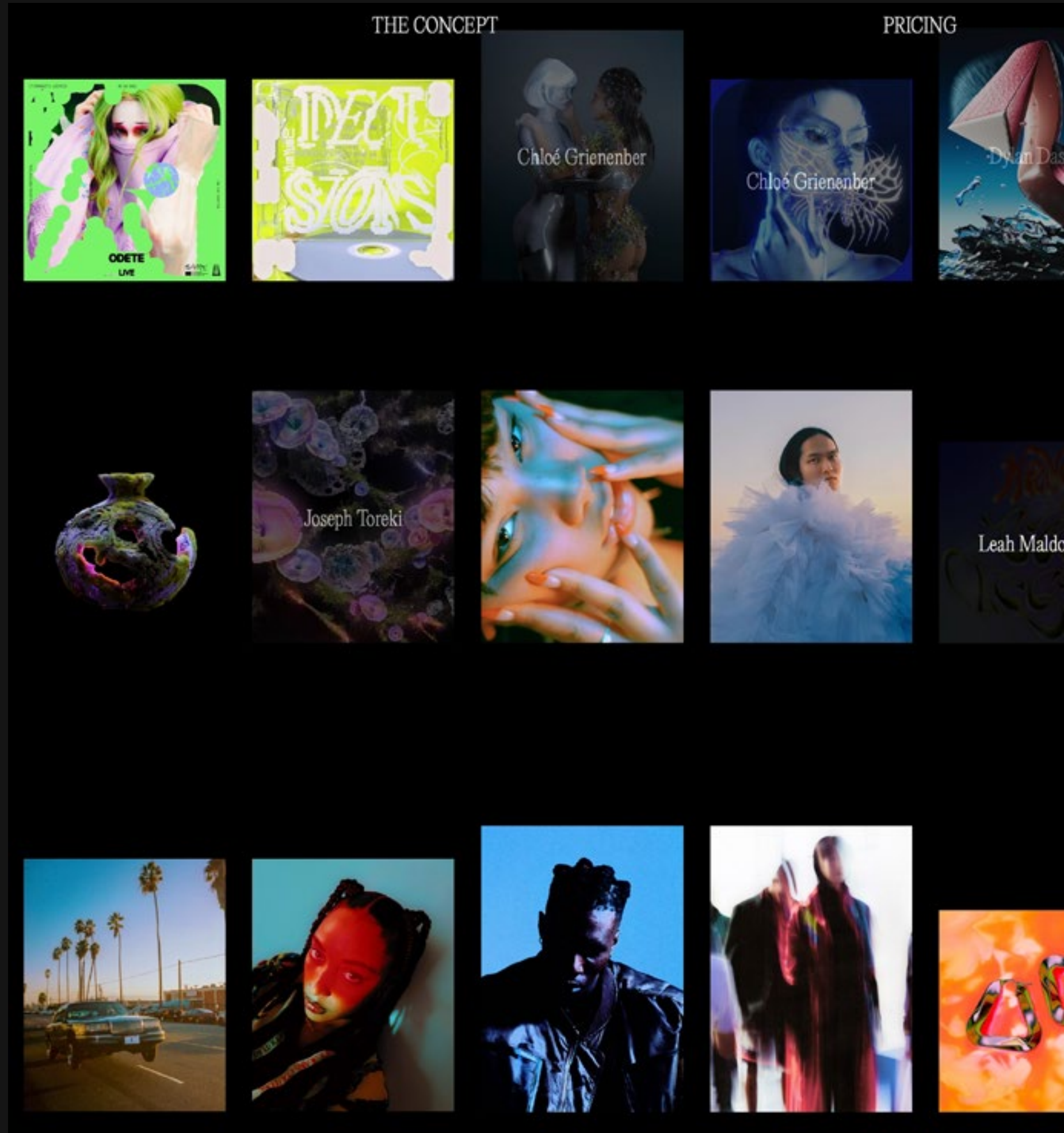

Noyce Club

CREATIVES CLUB PROJECT - 1 PAGE WEBDESIGN + CODING (WEBFLOW) 2023

THE CONCEPT

PRICING

EARLY ACCESS



OF CREATIVES

E

NOYCE is a Curation Platform highlighting a monthly selection of emerging creative talents. We are driven by innovation, daring inspiration and a desire to bring new artists into the established creative world. Our curation aims to encourage collaboration between new creatives and people like you, seeking to commission

THE CONCEPT

PRICING



YOUR EMAIL HERE

We'll keep you updated with the evolution. We do not spam. We will share any of your information

The Egg

GAMING - BETA TESTING

BRANDING

2019

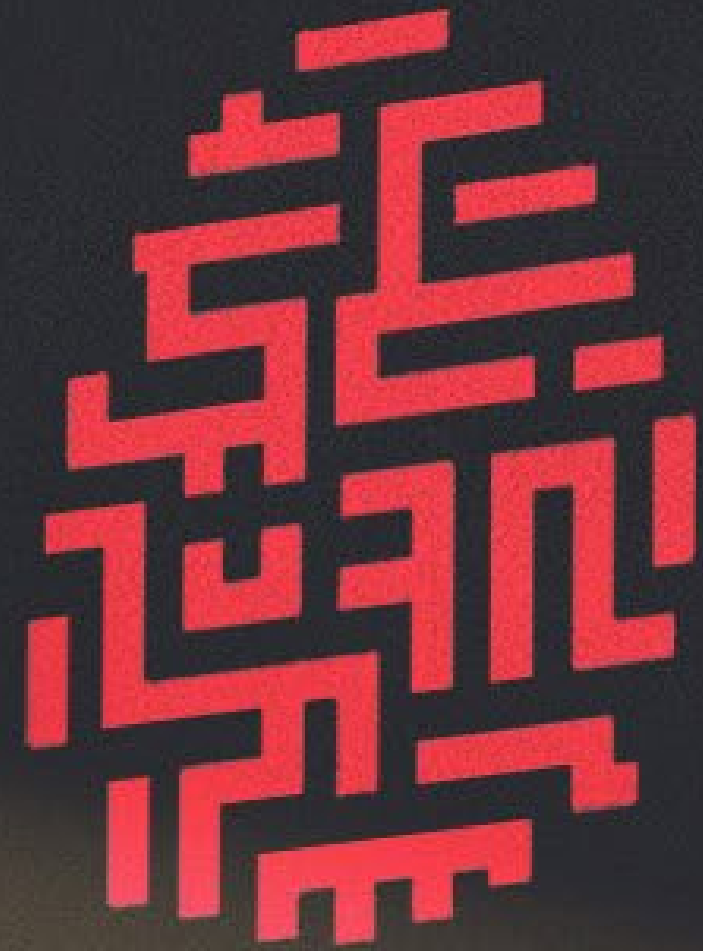

40-

ye!

ars

The Egg

GAMING - BETA TESTING

SCREEN DESIGN

2024

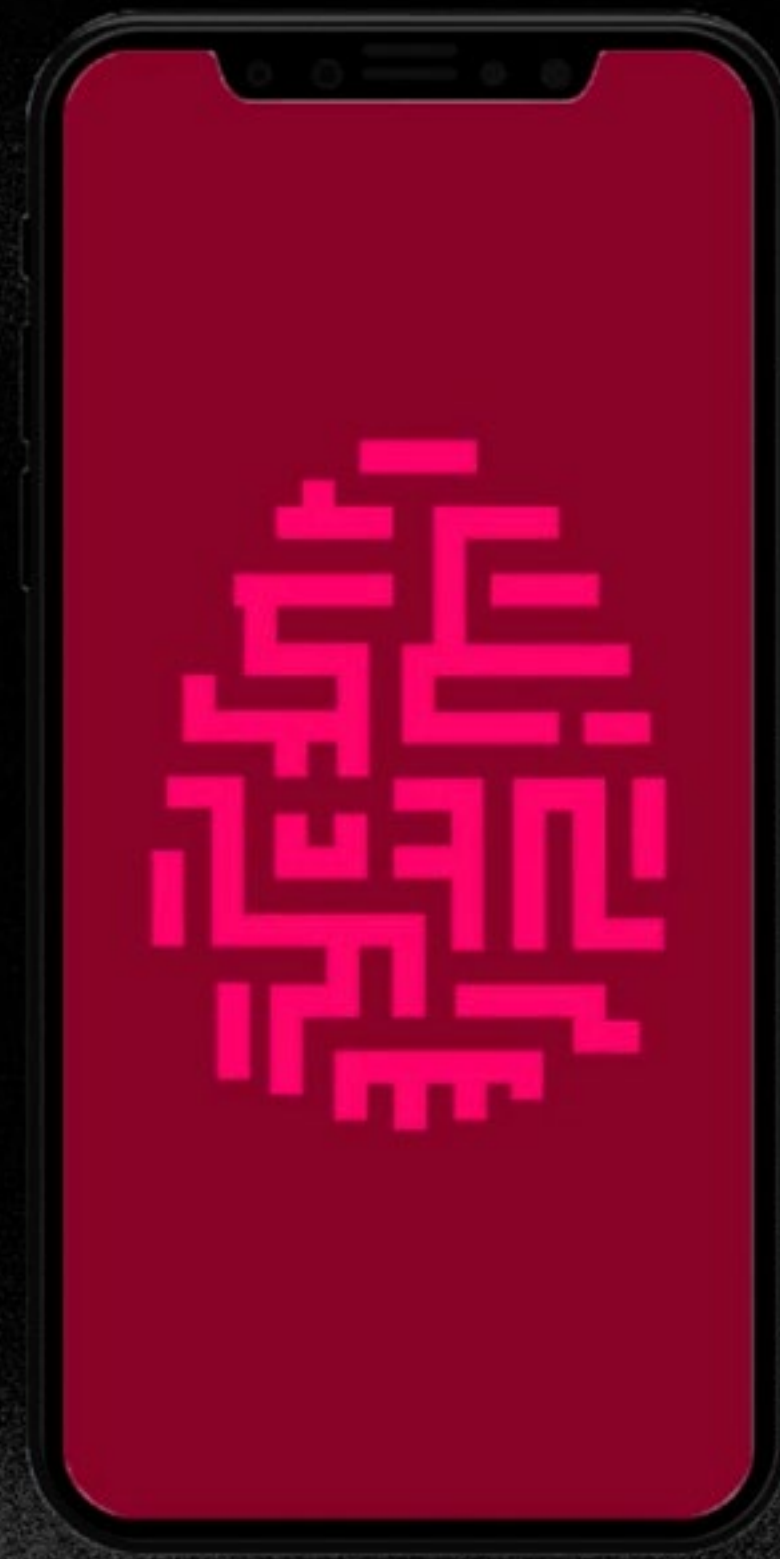

Diane Von Furstenberg

LOOKBOOK

WEBDESIGN

2024

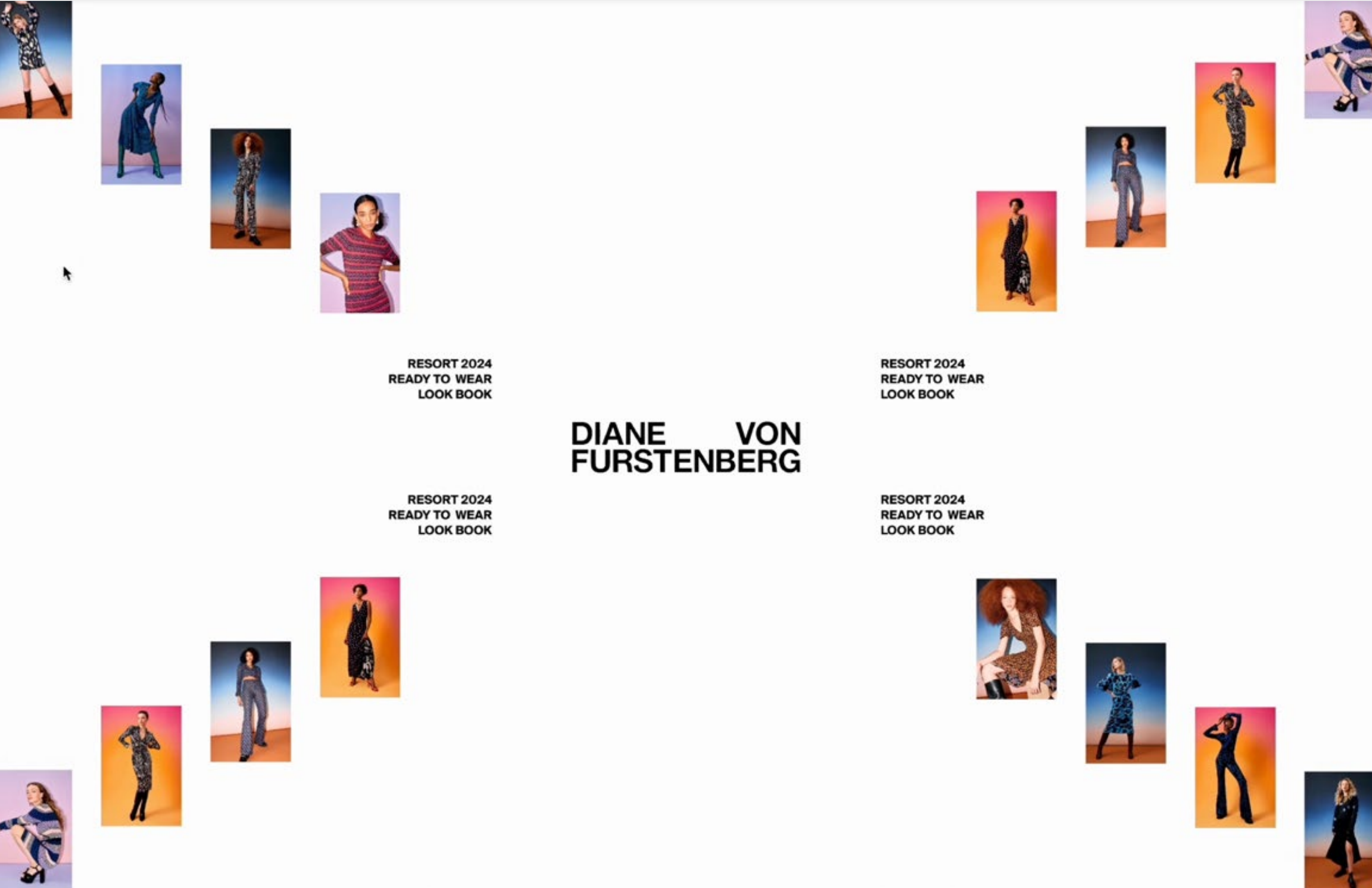

DIANE VON FURSTENBERG

RESORT 2024
READY TO WEAR
LOOK BOOK

RESORT 2024
READY TO WEAR
LOOK BOOK

RESORT 2024
READY TO WEAR
LOOK BOOK

RESORT 2024
READY TO WEAR
LOOK BOOK

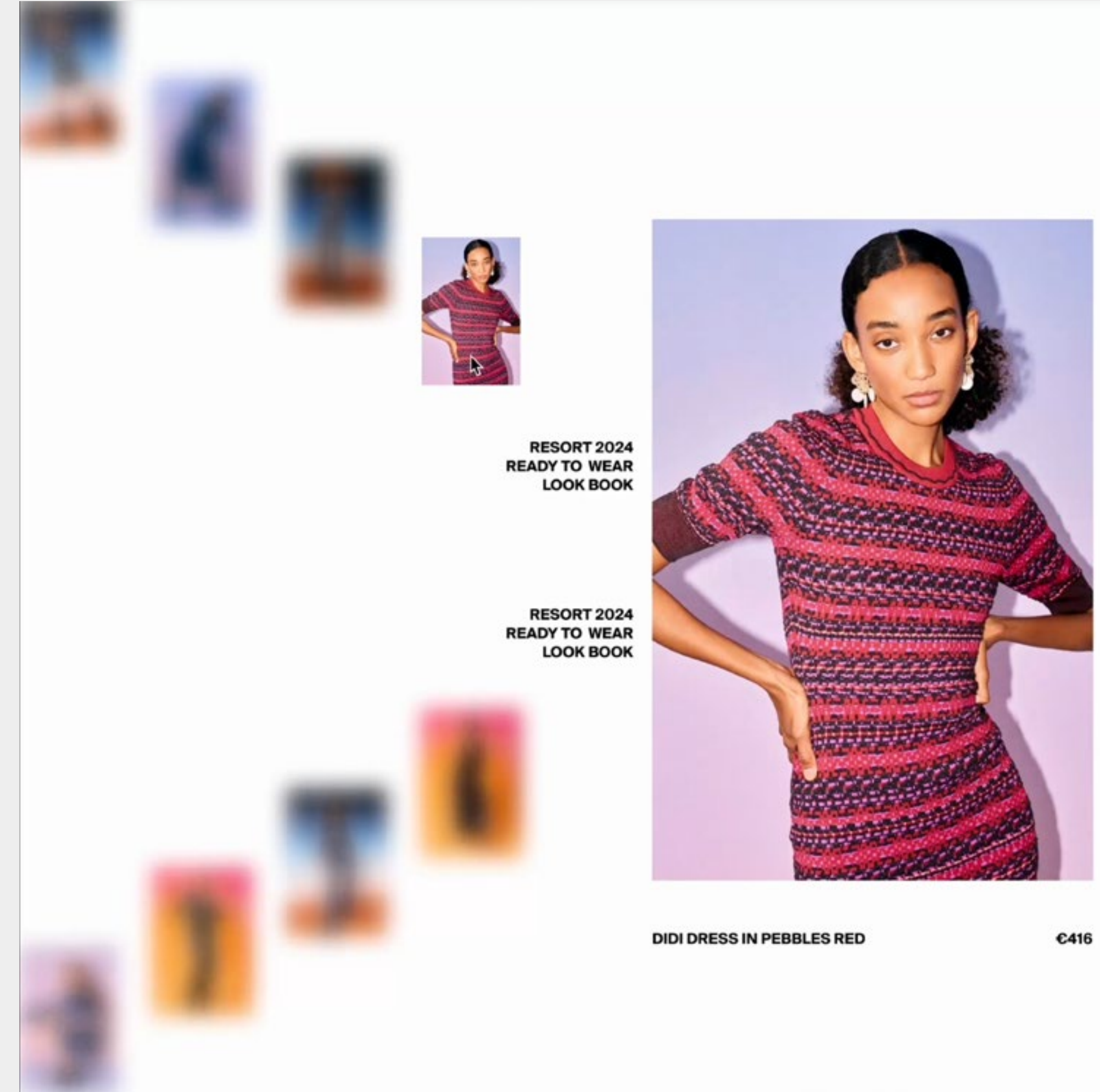

RESORT 2024
READY TO WEAR
LOOK BOOK

RESORT 2024
READY TO WEAR
LOOK BOOK

DIDI DRESS IN PEBBLES RED

€416

Diane Von Furstenberg

LOOKBOOK

CONCEPT WEBDESIGN

2024



[CLOSE](#)

DIANE VON FURSTENBERG

SOPHIE DRESS IN TINY CLOUD PATCH RED €396

SOFT AND LIGHT, THE SOPHIE DRESS IS CUT FROM A SUSTAINABLY-SOURCED CREPE. THIS PIECE MERGES THE TAILORING OF A SHIRT DRESS WITH THE EFFORTLESSNESS OF A WRAP. IT FEATURES A CLASSIC COLLAR, LONG CUFFED SLEEVES, BUTTONS UP THE FRONT, AND A MATCHING, WAIST-CINCHING TIE. LENZING™ ECOVERO™ VISCOSE FIBERS ARE CREATED FROM RENEWABLE WOOD SOURCES AND MANUFACTURED USING LESS WATER AND EMITTING LESS CO2. BETTER FOR THE ENVIRONMENT, BETTER FOR YOUR STYLE.

LRENA IS 178 CM AND WEARING A SIZE XS.

FABRIC CONTENT	60%ECOVERO™, 40%VISCOSE
WAIST	57CM TO 61CM
HIP	200CM
BUST	86CM
SLEEVE LENGTH	77CM

[SHOP ON DVF'S WEBSITE](#)



RESORT 2024
READY TO WEAR
LOOK BOOK

RESORT 2024
READY TO WEAR
LOOK BOOK

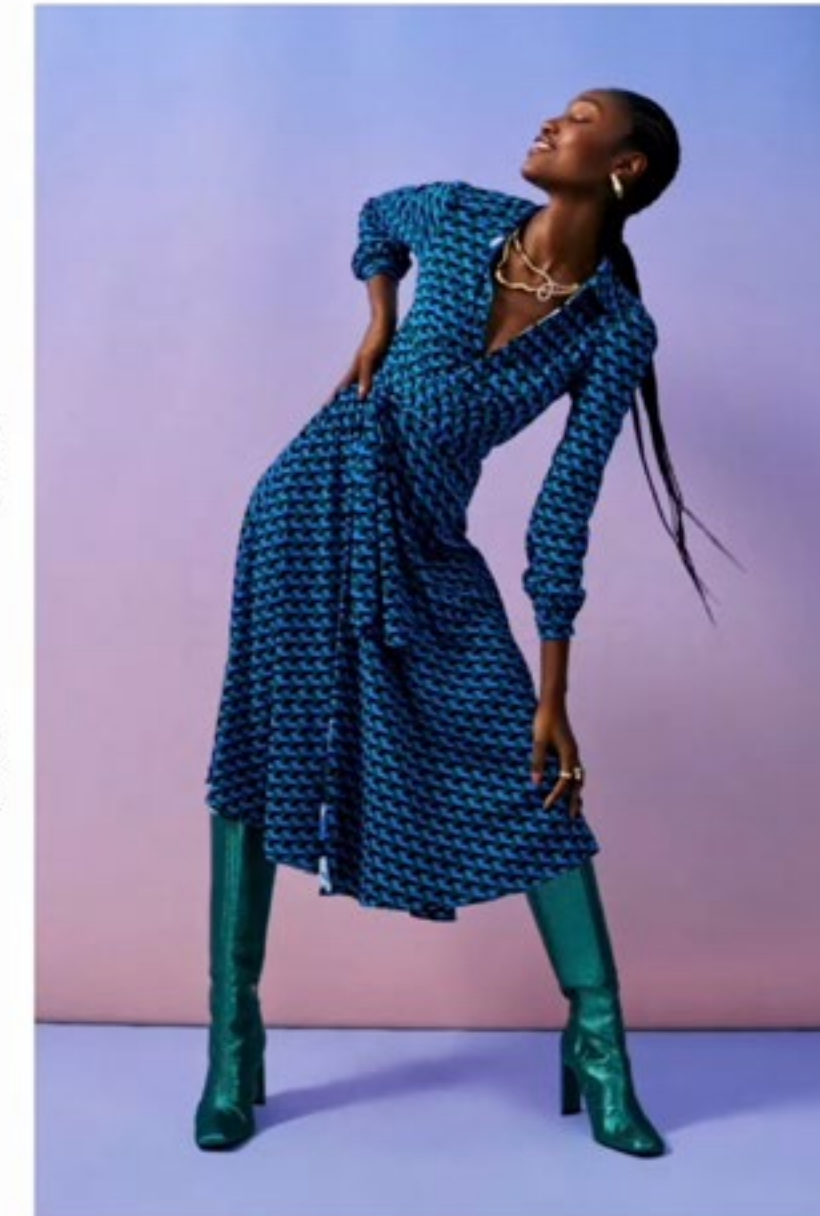

SHAWN DRESS IN SOLSTICE FLAGS BLUE

€635

The Bloom

FLOWERS & DESIGN

CONCEPT WEBDESIGN

2024

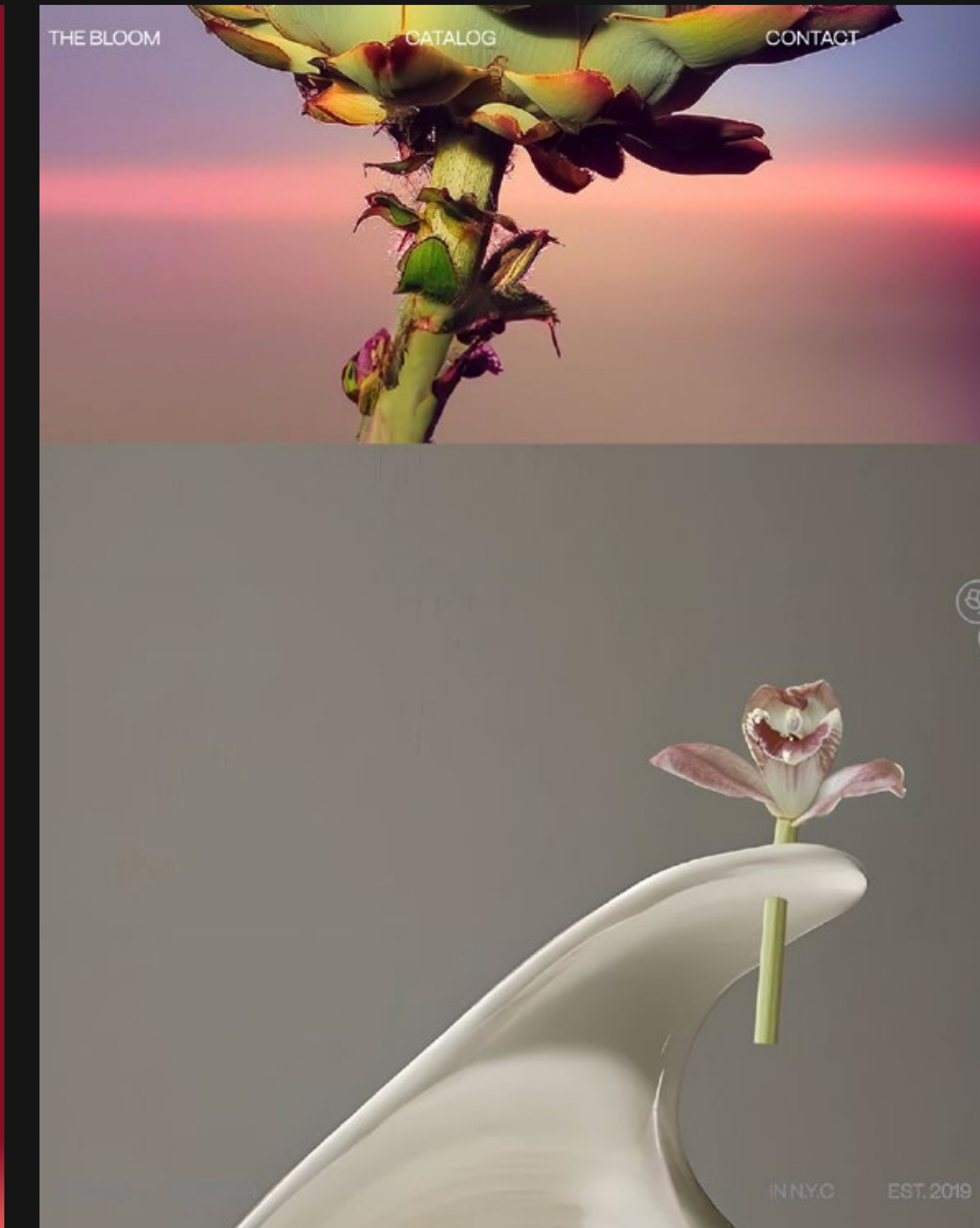

The Bloom

FLOWERS & DESIGN

CONCEPT WEBDESIGN

2024

Nestled in the heart of New York City, The Bloom: Concept House is not just a flower shop—it's a living canvas where nature meets avant-garde design. Founded in 2019 by a visionary French floral artist, The Bloom: Concept House has quickly become a beacon of creativity and innovation in the bustling metropolis. Our founder, with her unique blend of Parisian elegance and New York's dynamic energy, has transformed the art of floristry into an experiential journey. Each arrangement at The Bloom: Concept House is a meticulously crafted piece of art, designed to evoke emotion and inspire wonder.

Custom Bouquets

Personalized floral arrangements

Workshops

Creative floral design classes

Event Styling

Unique floral themes for any occasion

Art Installations

Large-scale, conceptual floral displays

Collaborations

Partner with artists & designers



THE
BLOOM
Current
Open

Monday - Friday

9AM - 8PM

Saturday

9AM - 6PM

Sunday

10AM - 3PM

Christmas

Custom orders only

& more...

EXPERIMENTS

WEBDESIGNS W/ FIGMA

2024

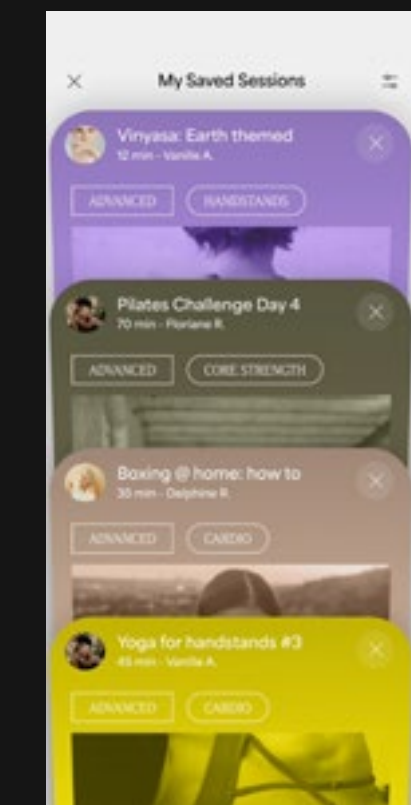
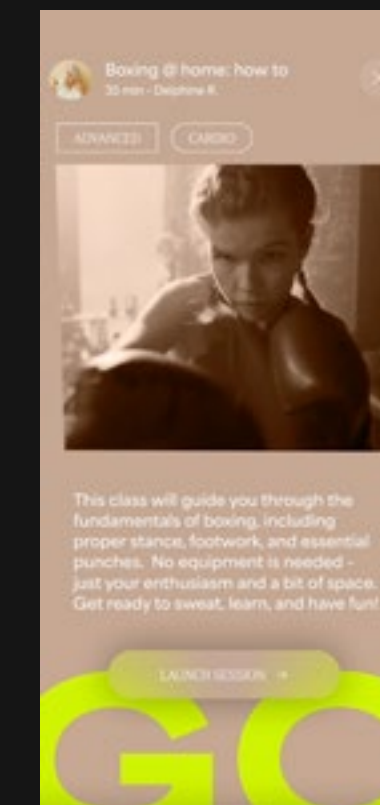
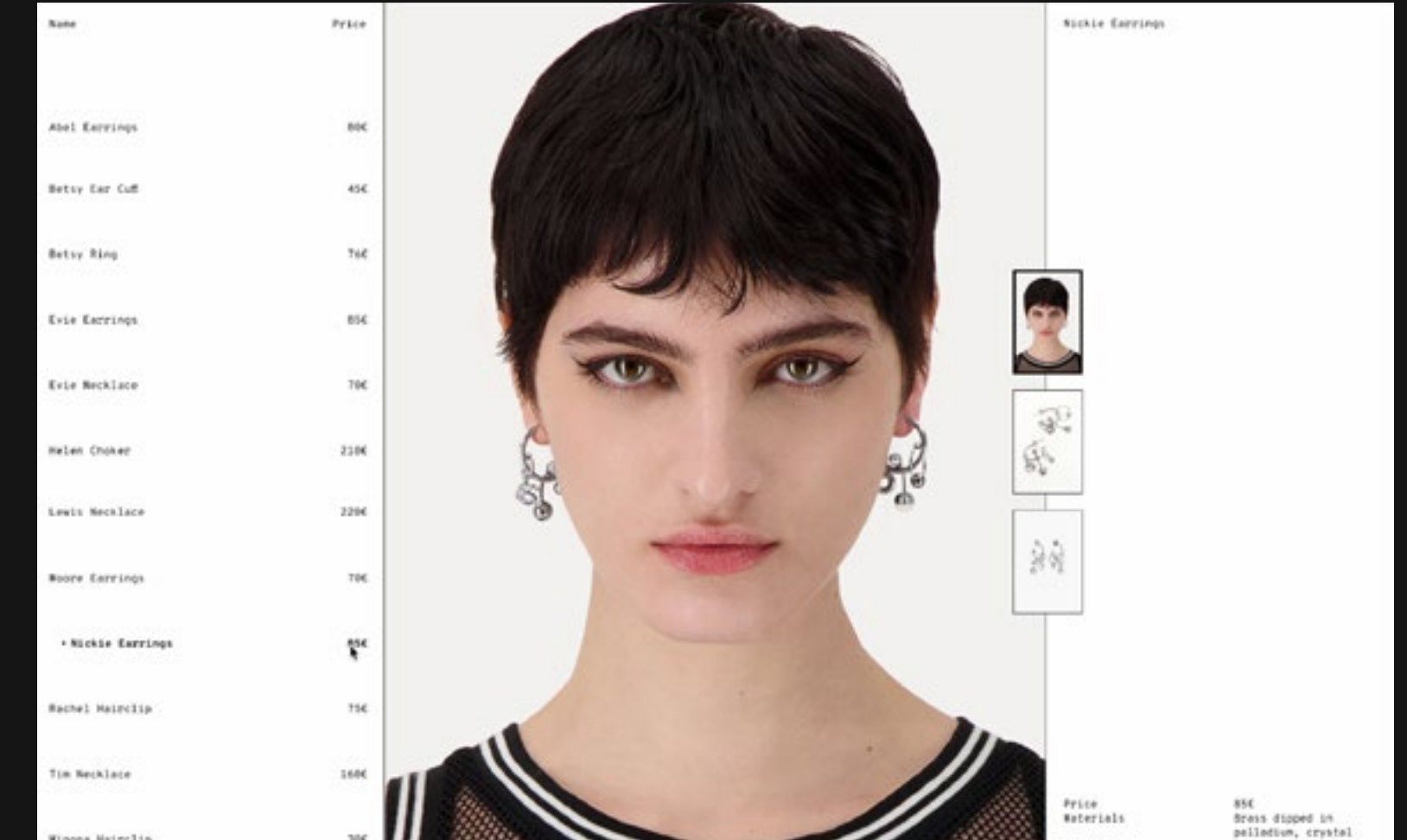

Teaching

SINCE 2017

WORKSHOPS

"UX/UI COMPETITION: NEW ONBOARDING FOR CROSSCALL" | ECV DIGITAL MASTERS, 2024

"CREATING A DIGITAL EXPERIENCE" | ECV DESIGN 3RD YEARS, 2024

"CREATING A VISUAL IDENTITY" | ECV DIGITAL MASTERS, 2024

"CREATING A PORTFOLIO ON WEBFLOW" | ECV DESIGN MASTERS, 2024

"WEBDESIGN & BRANDING" | INTUIT LAB MASTERS, 2023

"CREATING A VISUAL IDENTITY" | ECV DIGITAL MASTERS, 2023

"GABIE APP, STRATEGY & BRANDING" | ECV DIGITAL MASTERS, 2023

"EXPERIMENTAL APP DESIGN" | ECV DESIGN MASTERS, 2022

"L'ARCHE VERTE, BRANDING & STRATEGY" | ECV DIGITAL MASTERS, 2022

"WEBDESIGN & FIGMA FOR PROFESSIONALS" | INTUIT LAB PRO, 2021

JURIES

FIRST-YEAR PROGRESS COMMITTEE | ECV DESIGN, 2024

TYPE & EDITION - SPECIMEN BACHELOR'S COMMITTEE | ECV DESIGN, 2023

THESIS COMMITTEE MEMBER FOR MASTER'S DEGREE | INTUIT LAB, 2023

MASTER'S MID-YEAR REVIEW COMMITTEE | INTUIT LAB, 2023

MASTER'S ENTRY COMMITTEE (INTERNSHIP EVALUATION) | ECV DESIGN, 2023

MASTER'S ENTRY COMMITTEE (INTERNSHIP EVALUATION) | ECV DESIGN, 2022

FIRST-YEAR PROGRESS COMMITTEE | ECV DESIGN, 2022

MASTER'S ENTRY COMMITTEE (INTERNSHIP EVALUATION) | ECV DESIGN, 2021

COURSES

CURRENTLY TEACHING WEBDESIGN & FRONT-END CODING TO THIRD AND SECOND YEARS @ ECV PROVENCE

Featured

SINCE 2016

PRINTED FEATURES

DIGITAL UNDERGROUND VOL.1, TAVANO VINCENT, 2020

PLI REVUE: ARCHITECTURE & DESIGN, CONFLIT EDITION, 2017

ONLINE FEATURES

AIGA EYE ON DESIGN

ÉTAPES

THE DESIGN BLACK LIST

AWARDS

CSS AWARDS (1 AWARD)

FRENCH DESIGN INDEX (2 AWARDS)

FRENCHY AWARDS (1 AWARD)

MINDSPARKLE MAG (4 X VOTED SOTD)

AWARDS

CSS AWARDS (1 AWARD)

FRENCH DESIGN INDEX (2 AWARDS)

FRENCHY AWARDS (1 AWARD)

MINDSPARKLE MAG (4 X VOTED SOTD)

Thank you.

PHONE:
[+33\(0\)6.35.25.97.99](tel:+33(0)6.35.25.97.99)

WEBSITE:
WWW.TWISTUDIO.FR

INSTAGRAM:
[@TWISTUDIO](https://www.instagram.com/twistudio)

