

High-tech Automatic Straightening Machine

SL smart
Series 300



Link to Product Website



Link to Product Video



for Knits and Wovens

Straightening

Exhaust humidity

Fabric temperature

Pick/course density

Residual moisture

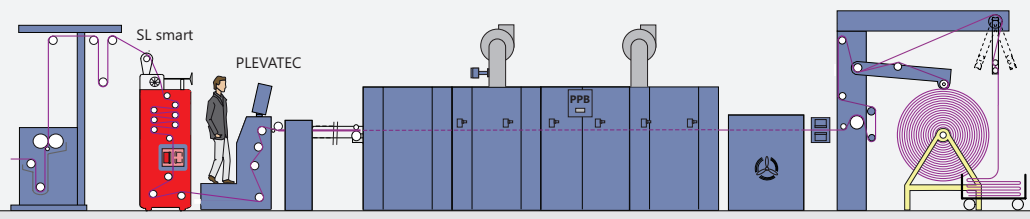

StraightLiner SL smart for universal application

Heroes for your process.

A high quality fabric is an essential requirement for any finisher who intends to ensure a consistency in quality and resource-efficiency. A particularly important quality criterion in this respect is fabric with straight weft and course. In order to achieve this in an optimum manner, the automatic straightening machine StraightLiner SL smart offers an extremely high level of efficiency which makes it possible to correct distortions over the shortest length of fabric.

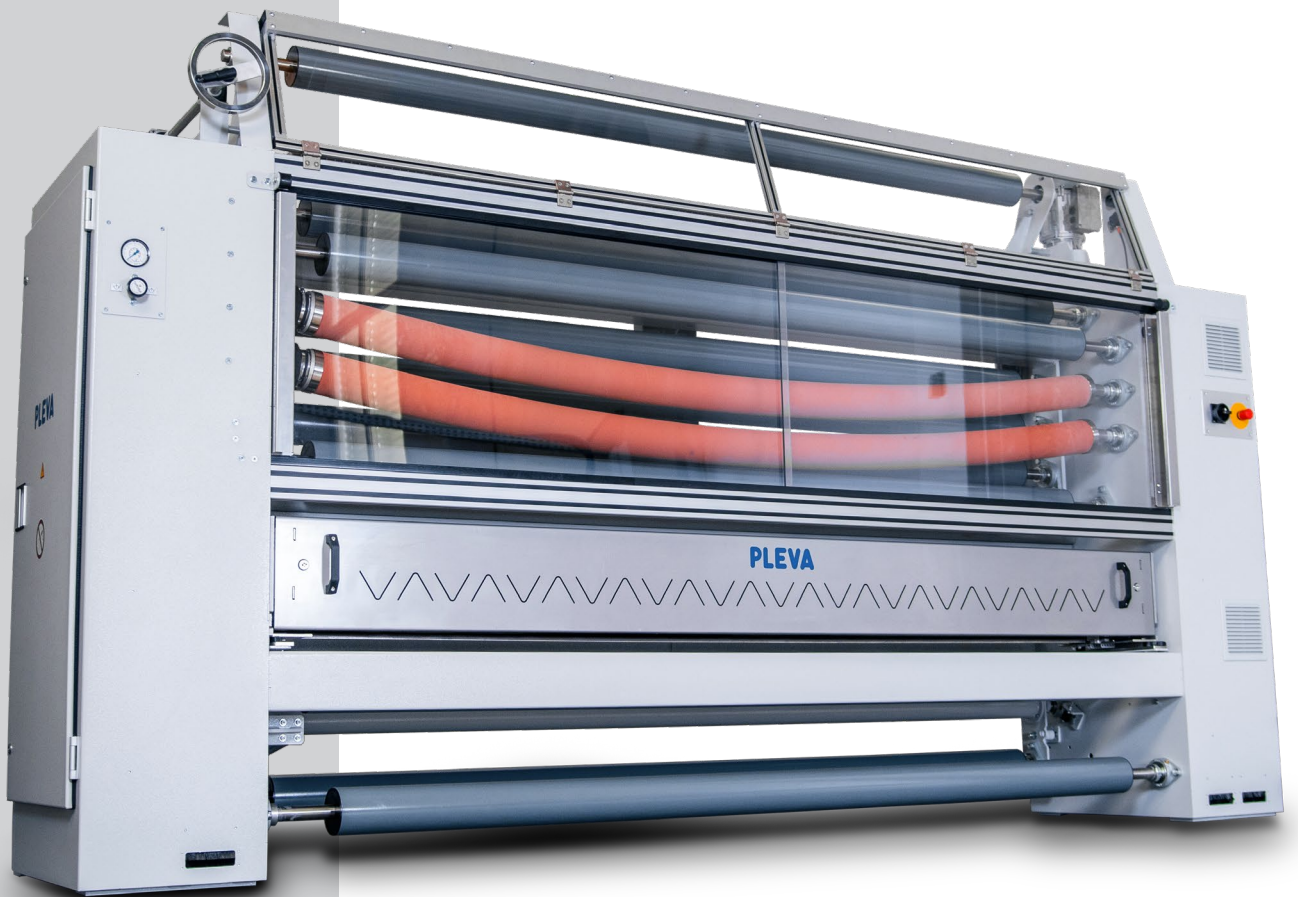

AREAS OF APPLICATION

- Stenter frame
- Shrinking machine (sanforizer, compactor)
- In washing-lines before dryer
- etc.

HIGHLIGHTS

- More than 50 years experience in textile industry
- Unique high-end distortion measuring system
- Engineered and built in Germany

Overview of key features

The straightening machine SL smart is designed particularly for knitted and light woven fabrics with a plurality of new design solutions.

Thanks to our many years of expertise in the textile industry, we know that individual processes and fabrics have specific needs. To optimally address the need of your application, we offer several options for customization like fully-integrated accessories for tension-sensitive fabrics, Industry 4.0 applications and more.

The heart of the SL smart system is the well-established advanced traversing camera technology which is unique in weft-straightening. The universal high-resolution camera captures up to 20 measuring points per meter of fabric width. Advanced evaluation algorithms enable an ultra-precise distortion analysis which enables perfect straightening results in a blink of time.

Get new insights and improve your production



With all PLEVA products, we aim to give you the best possible solution, fitted to your individual needs. Therefore, a new customizable user-interface was designed. It displays all important informations at one glance, so you can work with maximum efficiency.

HMI with individualizable overview-page (SL smart with options for process control)



Meet the highest standards in sustainability and efficiency of your production

Nowadays, products have to meet not only economical but also ecological standards. Our weft-straightener SL smart not only helps you to get the best quality out of your goods, but also helps to improve the sustainability of your production. Due to our "first-time-right-principle", you only have to go one round through the production line with your fabric and produce directly the desired quality. This saves energy and valuable resources. In addition, due to the higher quality of the goods, there are no more costly readjustments or wasted fabrics and customer complaints can be reduced drastically. This is not only good for you and your customers, but also for the environment.

To further enhance the efficiency of your processes, a modular control system (PLEVATEC smart) can be directly integrated into the machine. This allows to measure, control, visualize, and protocol the critical parameters of your specific process, for instance:

- Exhaust humidity (FSX)
- Fabric temperature (TDS)
- Pick/course density (CAM)
- Residual moisture (RR/RF 120)

BENEFIT FOR CUSTOMER

- Customizable machine
- Intuitive user-interface
- Full integration of process control
- Modular process control options
- Efficiency through „first-time-right-principle“
- Improvement of product and process quality
- Short payback period
- Future-proof for updates and upgrades

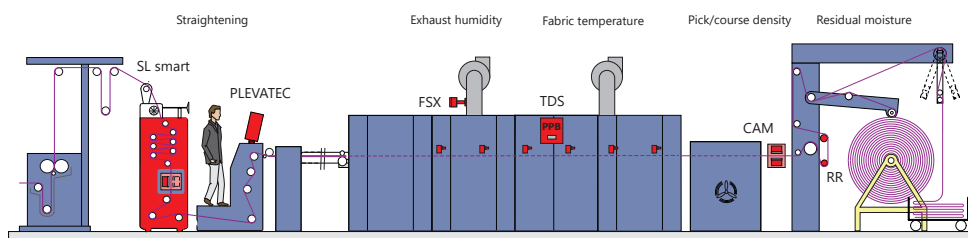

SL smart and PLEVATEC smart on stenter

The smart way of weft-straightening.

CAM for distortion analysis and pick/course density

Type CAM series 300

FEATURES OF PRODUCT

- High-intensity colour neutral infrared flash
- Automatic brightness control
- Calibration free
- Advanced distortion evaluation
- Robust, compact system
- Plug & Play connectors

Technical features

Universal high-resolution camera for easy detection of a huge variety of fabrics

- Image capturing in 0.00001 seconds
- Picture size standard: 40 x 30 mm
- Reflecting lighting
- High-speed analysis >10 times per second
- Picture analysis independent of fabric speed. From stand still up to fabric speeds of 600 m/min.

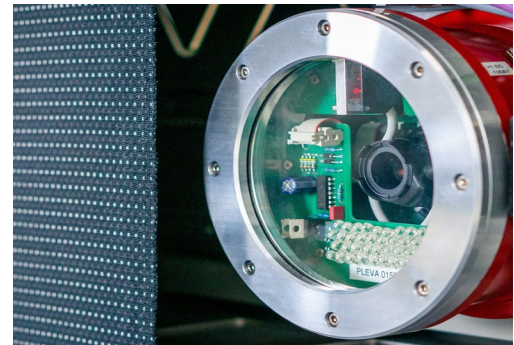

CAM series 300 fabric sensor, lens and LED reflecting lighting

CAM systems for different applications

With more than 20 years of experience in the field of high-tech camera image processing for textile goods, many solutions for difficult applications have already been developed.

- **CAM Standard**, universal applicable from 2 to 75 picks/cm
- Other CAM systems for special applications on request

Lighting option

• **High-intensity infrared transmitted lighting**

for even greater range of detection capability and pick/course density measurement (option)

Unrivalled structure analysis with self-tuning detection

Self-tuning detection camera

BENEFIT FOR CUSTOMER

- Maximum detection capability
- Smart image processing CAM
- High-precision distortion analysis
- Density measurement (option)

Smart image processing

- Universal, self-optimizing detection
- Horizontal distortion
- Brightness control
- Advanced, self-made digital signal processing
- Horizontal density (picks/courses) (option)
- Vertical density (warp/wales) (option)

Any structured textiles

- Warp-knitted fabrics
- Weft-knitted fabrics
- Africa damask
- Automotive seat fabrics (woven and warp knitted)
- Camouflage fabrics
- Complex „Jacquard“ fabric
- Corduroy
- Curtain
- Fantasy design
- High-quality fabrics for automotive industry
- Light and tension sensitive inlet fabrics (woven and raschel lace < 20 gsm)
- Jacquard
- Stripe satin
- Technical filter material

CAM pictures with smart distortion angle and density analysis

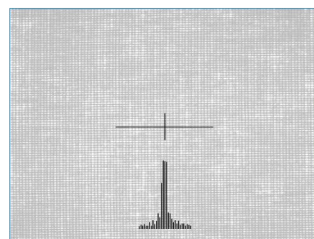

Jacquard woven fabric

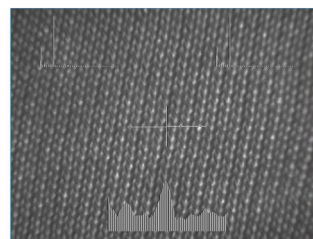

Knitted fabric

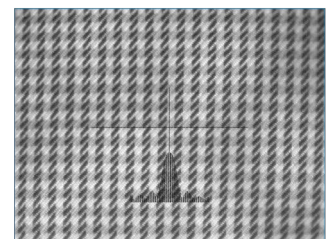

Technical textiles

Unique traversing camera concept

Outstanding capabilities of SD

The StructureDetector SD series 300 with its camera traverses continuously back and forth across the complete fabric width. The camera takes high-resolution pictures at numerous points and analyzes these individual pictures in fractions of a second. After each evaluation, the total distortion of weft threads or knitted courses is calculated and split up into its skew- and bow-components.

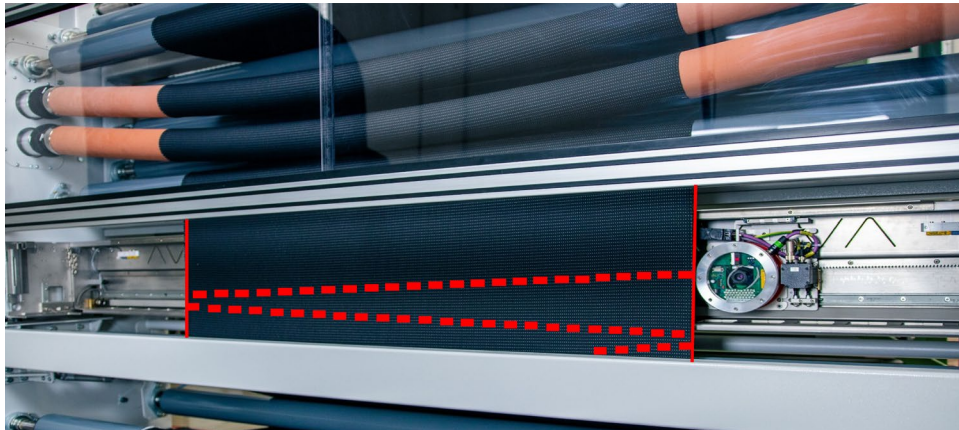

StructureDetector SD series 300 with large area structure scan

- Precise distortion measurement due to many measured values over fabric width (e.g. up to 40 measured values for 2000 mm fabric width) independent of fabric speed (even at stand still)
- Selvege to selvege coverage over the complete fabric width
- Automatic width adjustment of the traversing range of the camera after fabric change
- Traversing speed can be adjusted to fabric width and fabric speed

Type SD series 300

BENEFIT FOR CUSTOMER

- Precise distortion analysis from selvege to selvege
- Indication of fabric position relatively to center
- Integrated fabric width measurement

Ingenious traversing system

The extensively tested traversing mechanism is the strong foundation of SD series 300. It is fitted to even the harshest working conditions and optimized for easy maintenance. The key-features of the specially designed traversing system are:

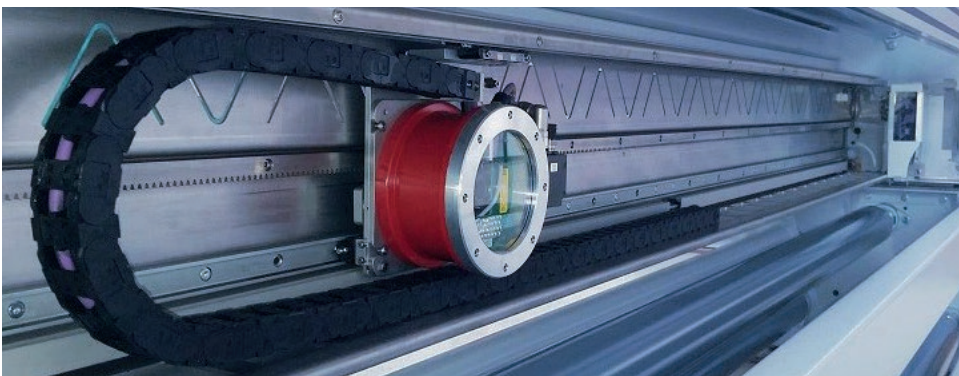

StructureDetector SD in stainless steel construction

- High-speed traversing adjustable up to 150 cm/sec
- Made of stainless steel for the toughest environments
- Intelligent motor management
- Double rail and double slider system

BENEFIT FOR CUSTOMER

- Automatic traversing adjustment, no manual settings required
- Plug & Play connectors
- Easy access for cleaning and maintenance

High performance, intuitive user interface

- ① Modular overview of controls
- ② Status information bar
- ③ Current values with tolerance indication
- ④ Trend and visual representation
- ⑤ Controls with status

BENEFIT FOR CUSTOMER

- Easy to use, intuitive user interface for operator
- Extremely robust 12" HMI touch panel
- Modular concept for upgrades

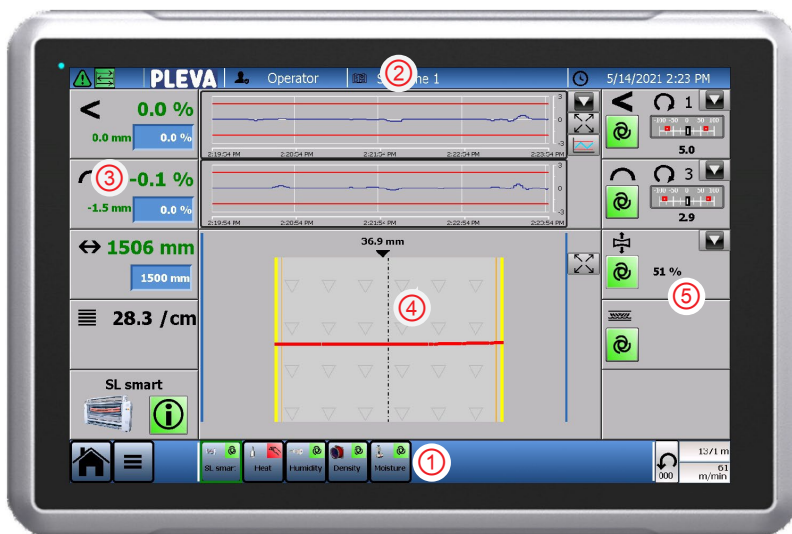

HMI touch panel

The newly designed user interface provides an overview of the most important information such as all relevant measuring values, tolerances and status information.

The high-performance 12" HMI touch panel can withstand surrounding temperatures of up to 60°C without cooling and is suited for the roughest working environments.

Realistic representation of the running fabric

- ① Fabric distortion from selvage to selvage
- ② Integrated measurement of fabric width
- ③ Indication of fabric position relatively to center
- ④ Max. possible fabric width in machine

FEATURES OF PRODUCT

- Direct readout of skew and bow in % and mm/inch
- Integrated width display in mm/inch
- Indication of fabric position in mm/inch
- Visual representation of the actual running fabric

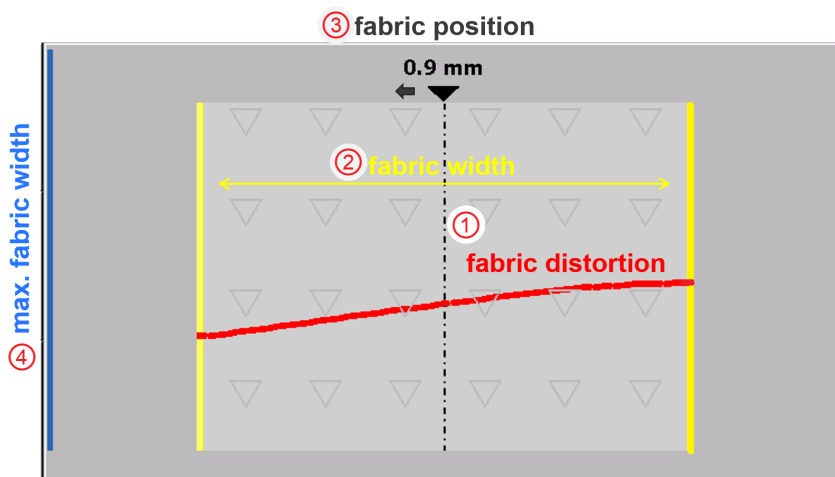

Realistic representation of fabric distortion

Through the unique capabilities of the traversing camera system SD series 300, further quality-critical fabric information like the actual fabric width, an indication of the fabric position, and even a sectional evaluation of the local distortion in skew and bow can be provided. This enables a completely unique overview of the actual running fabric. The actual values for skew and bow are shown in % and mm/inch.

Built-in trends and recipe management

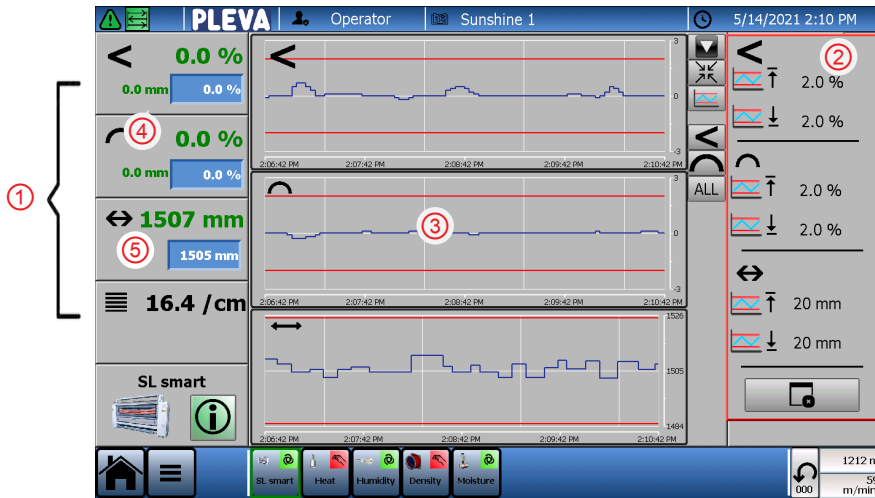

Screen shows history and tolerances

HISTORY AND TOLERANCES

- ① Actual, set values, width and density (option)
- ② Tolerance monitoring
- ③ Standard trends and actual width
- ④ Display of distortion in % and mm/inch
- ⑤ Width in mm or inch

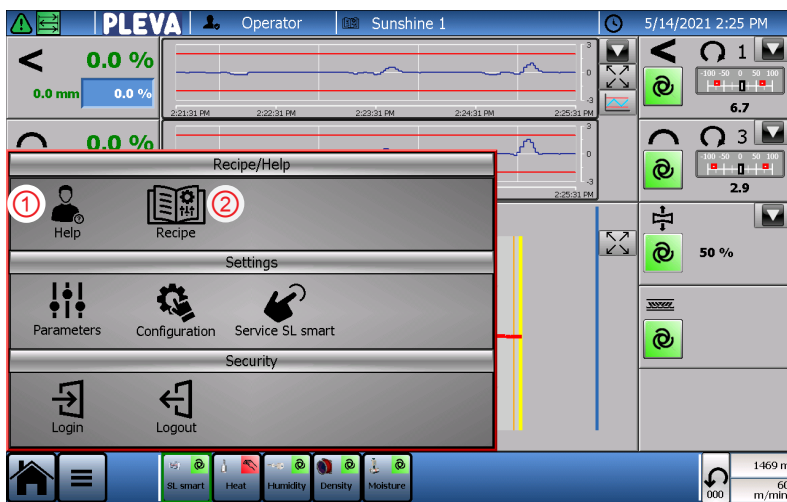

Screen shows additional features

ADDITIONAL FEATURES

- ① Manuals as PDF directly available in HMI
- ② Integrated recipe management

BENEFIT FOR CUSTOMER

- Monitoring of consistent high quality with trends and tolerances
- More efficiency due to recipes

To ensure that the process is running smoothly and every running meter of fabric is produced in the desired quality, different trends are provided. Additional trends for comparing skew/bow and the position of the skew-/bow-rollers are also directly available. Furthermore, the integrated recipe management provides a database for all critical set-values, tolerances, controller pre-sets, detection parameters, etc.. This allows the highest level of reproducibility for different products and enables easy operation.

Interface options

To maximize the capabilities of the SL smart, several current connection standards are supported and connection to several Industry 4.0 applications can be realized. Connections to production lines, MES- and ERP-systems can be realized through:

- ProfiNet or ProfiBus (option)
- OPC UA (option)
- CSV files (option)

PRS (PLEVA Remote Service) (option)

For a state of the art instant service of the straightening machine, an industrial router can be provided for remote access and service. This can help to further maximize the availability and performance of the SL smart.



Skew- and bow-roller adjustment

BENEFIT FOR CUSTOMER

- Maintenance-free skew- and bow-roller adjustment-drives with integrated position feedback
- Precise and fast positioning for smooth motion control
- Directly controlled from PLC
- Plug & Play connectors

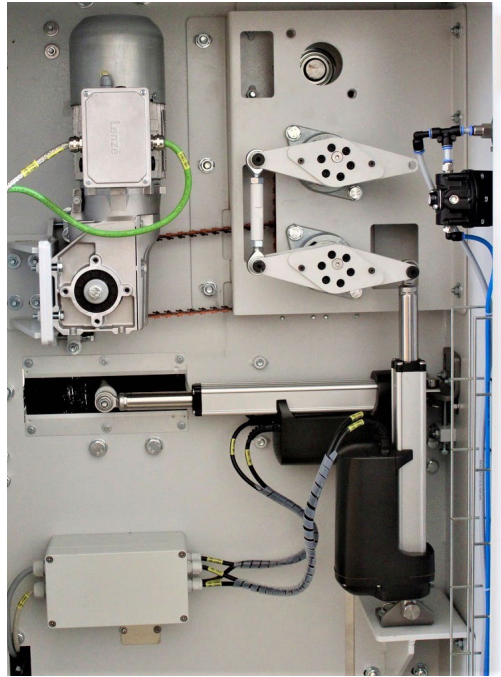

Drive side

For optimal durability and cost-efficient running the positioning of the skew- and bow-rollers has been designed from the ground up. The actuators for the positioning of the skew- and bow-rollers are completely encapsulated and completely maintenance-free.

The integrated position feedback and the high-performance spindle drive system provide extremely fast and precise positioning of the straightening rollers. The maximum theoretical straightening effect for skew is $\pm 980\text{mm}$ and $\pm 600\text{mm}$ for bow distortions. With the fast adjustment for skew and bow and speeds up to 220mm/s for skew and 135mm/s for bow, perfect straightening results are easily achievable.

Machine configurations

BENEFIT FOR CUSTOMER

- Bypass of straightening rollers
- Optimized and short fabric paths
- Easy accessibility

Examples for knitted and woven fabrics

The straightening machine SL smart is designed to perfectly meet the specific needs for knitted and lighter woven fabrics. All aspects of the machine are optimized for low and easy maintenance.

For fabrics that should not be corrected by the straightening machine, but quality should be logged by the SD series 300, a bypass through the machine without touching is available.

- ① Decurling unit (option)
- ② Additional inlet-roller (option)
- ③ 3rd bow-roller (option)
- ④ Pneumatic swing or LoadCell for fabric tension-control (option)
- Fabric path with straightening function
- Fabric path with bypass of the straightening rollers

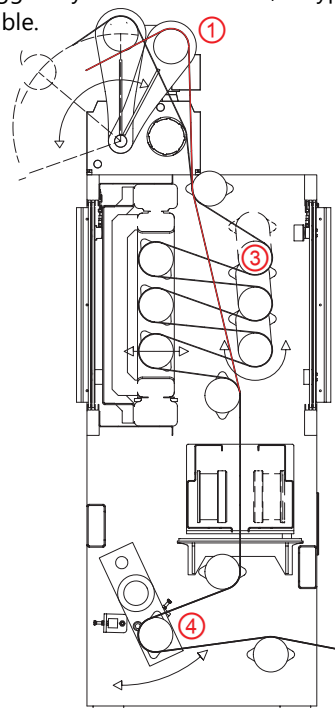

Fabric paths for machine with decurling unit, 3rd bow-roller and tension control with pneumatic swing.

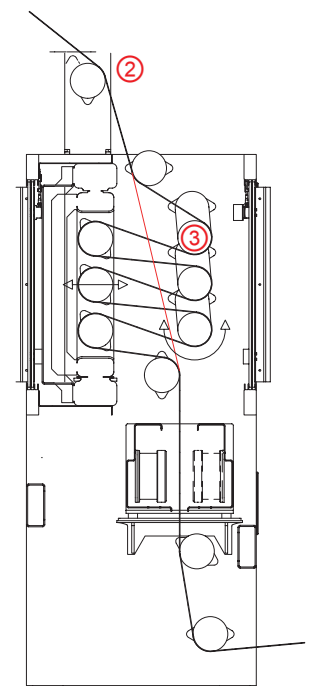

Fabric paths for machine with additional inlet-roller and 3rd bow-roller.

Additional options

The standard ceramic coated aluminium rollers of the SL smart are optimized for knitted goods, which usually need to be transported through the process with rather low fabric tensions. With the very low friction bearings and the low inertia of the lightweight rollers, the knitted fabrics are optimally guided. For applications with higher fabric-tension, stainless steel rollers are available as well.



Decurling unit



Rollers straightening unit

To perfectly straighten your fabrics, the individual properties of fabric must be taken into account. In the case of dimension-instable goods, such as knitted fabrics, a decurling unit is necessary to prevent the fabric edges from curling.

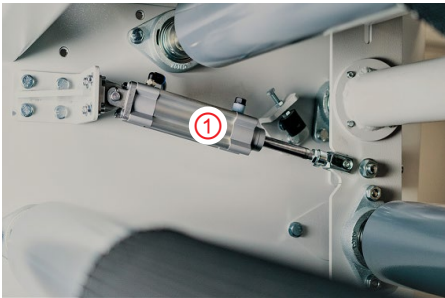

Pneumatic swing-mechanism

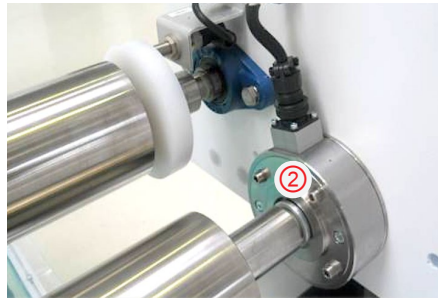

LoadCell

For tension sensitive fabrics, e.g. knitted fabrics or light woven fabrics, controlled tension throughout the complete production process is necessary. To perfectly suit individual applications and preferences, two different options to control the fabric tension inside the straightening machine via the driven bow-rollers are available:

- Pneumatic swing with the capability to compensate varying tensions/lengths
- Exact tension measurement and control with LoadCell, which can be managed in the recipe management.

- ① Fully integrated spreading / decurling unit (option)
- ② Belt-driven bow-rollers to support tension sensitive fabrics (option)
- ③ Ceramic coated aluminium, alternatively stainless steel

- ① Pneumatic swing mechanism for stepless fabric tension adjustment (option)
- ② Tension-measurement with LoadCell for precise tension control (option)

Options overview

Fabric width

_____ mm

Max. fabric width 1800, 2000,--, 2800mm
(Coated AL-roller, max. tension 500N)

or

Max. fabric width 1800, 2000,--, 3000mm
(Stainless steel-roller, max. tension 1000N)

CAM / SD

Standard 2-75 courses/cm

or

Other cameras on request

High-intensity additional trans.-light

Roller-type

Coated AL-roller^{max. 500 N}

or

Stainless Steel-roller^{max. 1000 N}

Bow-roller quantity

2x bow-roller

or

3x bow-roller

Tension control bow-drive

Pneumatic compensator

or

LoadCell

Decurling-device

Integrated

HMI

Integrated in machine-door

or

Separately

Protective cabinet

Rotating base for protective cabinet

Connection cable kit HMI

Interface options:

Profibus

or

Profinet

OPC UA

CSV

PRS (Remote Service)

Configurable options



Fully integrated process control for textile finishing processes in SL smart

BENEFIT FOR CUSTOMER

- Stable and controlled processes
- Higher quality of final product
- Energy efficiency
- Increased productivity
- History of processes
- Short payback time
- Integrated recipe management
- Easy to use

To get the most out of the weft-straightener SL smart a modular and completely integrated process control system is available. Most textile finishing processes consume a lot of energy and a high level of quality for the finished goods is obligatory. The final quality of the finished goods are mainly determined and influenced by the finishing department. Therefore, optimal processes and tight tolerances have to be met.

With the modular process control system PLEVATEC smart, all critical data can be collected and optimal controls can be realized. All set-values, tolerances and parameters can be saved and loaded within the integrated recipe management system.

The scalable packages provide solutions to a range of different finishing and drying processes e.g. on a stenter frame.

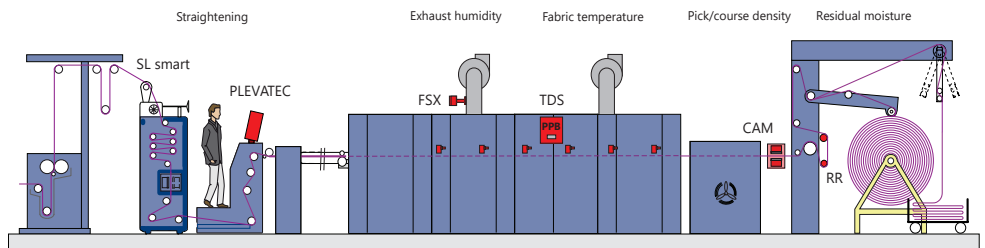

PLEVATEC smart and PLEVA sensors on a stenter frame

Devices	Measured value	Control value	Control name
TDS	Fabric and air temperature	Machine speed	HeatControl smart
FS	Air humidity	Exhaust fan speed	HumidityControl smart
RR	Residual moisture	Machine speed	MoistureControl smart
CAM Outlet	Picks and course density Outlet	Overfeed roller feed-back	DensityMonitoring smart / DensityControl smart
CAM Inlet	Picks and course density Inlet	Overfeed roller feed-forward	DensityMonitoring smart / DensityControl smart
RF 120	Residual moisture	Machine speed	MoistureControl smart

HeatControl smart | Dwell-time and exit temperature measurement and control

FEATURES OF PRODUCT

Dwell-time control

- Stable and controlled timing
- Approximately 25% productivity increase (speed)

Exit temperature control

- Approximately 30% productivity increase (speed)

For all fabric temperature-critical processes, the proven and unmatched TDS sensor can provide the actual fabric temperature and even the actual air temperature next to the fabric. The fabric temperature provides valuable insights about the heat treatment or drying process inside the stenter-frame.

The software-module HeatControl smart can evaluate the current dwell-time or the exit temperature of the fabric. By setting and controlling either of those critical target values, the production efficiency can be improved significantly.

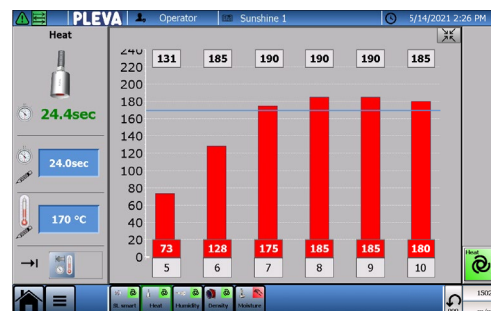

Screen shows HeatControl smart



TDS sensor

HumidityControl smart | Exhaust humidity measurement and control

By their nature, most drying processes are very energy-intensive and can be a major cost driver. On a stenter frame, a large part of the energy is used to heat the air, which is supposed to evaporate the water from the fabric and carry it away. In order to have to heat as little air as possible and save energy, the process exhaust air must be loaded with water as much as possible. With our globally proven air humidity sensor FSX, the continuous measurement of exhaust air humidity in connection with the control of exhaust air fans enables significant energy and CO₂ savings.

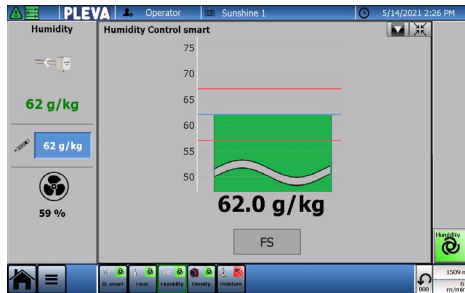

Screen shows air HumidityControl smart



FSX sensor

FEATURES OF PRODUCT

- Exhaust humidity control for up to 3 exhaust fans (0-10V)
- Controlled and stable drying climate
- Approximately 20% energy saving
- Up to 200 t CO₂ reduction per year

MoistureControl smart | Residual moisture measurement and control

With our range of residual moisture measurement sensors (RR or RF120) the residual moisture of fabrics after drying processes can be precisely measured for a large amount of fiber compositions.

After drying processes the fabric usually takes on the ambient moisture, resulting in a defined equilibrium material moisture content. Therefore, the moisture at the end of the drying process must be precisely controlled to avoid over- or under-drying the fabric, if possible. Overdrying represents a waste of production capacity and energy.

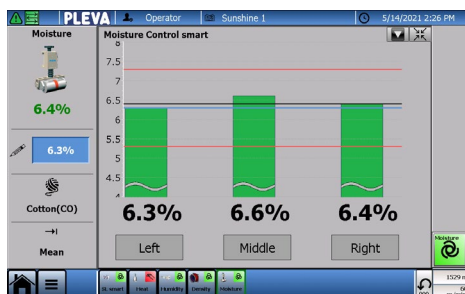

Screen shows fabric MoistureControl smart



RR Wide

FEATURES OF PRODUCT

- Prevention of overdrying resulting in a better surface quality
- Approximately 30% productivity increase (speed)

DensityMonitoring smart | DensityControl smart | Pick-/Course measurement and control

For a lot of textile processes the pick/ course density measurement is a critical quality-parameter. With our CAM systems and the advanced evaluation algorithms a reproducible measurement of a large variety of fabrics is possible. For different applications we offer a monitoring and, as an upgradeable option, a control system.

- DensityMonitoring smart for measurement and recording the pick/ course density at the outlet and/or inlet at the process line.
- DensityControl smart for measurement, recording and controlling the pick/ course density to control the exit density and evaluating the shrinkage.

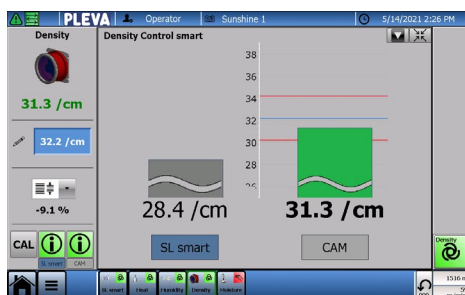

Screen shows DensityControl smart



CAM outlet

FEATURES OF PRODUCT

- Monitoring of final density of pick/ course density
- Control of overfeed (stenter frame) or belt pressure (shrinkage unit)
- Indication of fabric weight (g/sm)
- Evaluation of shrinkage (In/Out system necessary)
- Optimized and reproducible fabric density

Technical drawings

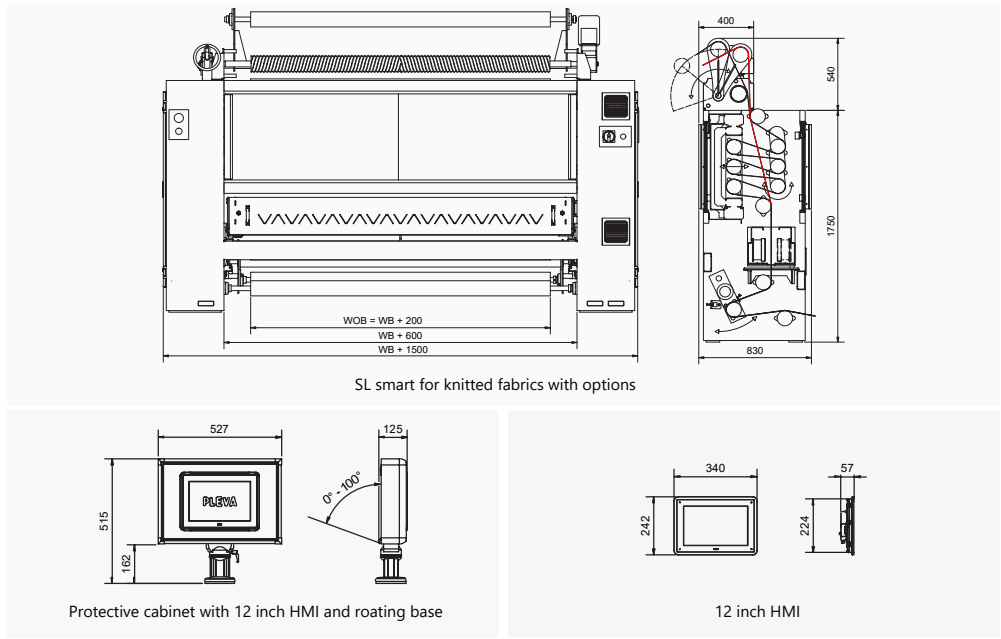

Technical data

Ambient temperature:	max. 55 °C
Power supply:	3x 400V AC
Frequency:	50/60 Hz
Power consumption:	from 2,2 to 3,8 kW
Current:	from 4 to 7.2 A
Coated AL-roller:	max. tension: 500N, Ø115mm Fabric width: 1800, 2000,...,2800mm
Stainless steel roller:	max. tension: 1000N, Ø115mm * Fabric width: 1800, 2000,...,3000mm
Bow roller:	Ø110mm, Deflection: 88-112mm depending max. fabric width
Straightening roller skew and bow adjustment:	Maintenance-free spindle drive adjustment with integrated position-feedback; accuracy 0,5mm
Range of adjustability skew (WB 2400mm):	skew: max. ± 980mm
Range of adjustability bow (WB 2400mm):	bow: max. ± 420mm (2 bow-rollers) max. ± 600mm (3 bow-rollers) *
Adjustment-speed skew:	max. 220mm/s
Adjustment-speed bow:	max. 95mm/s (2 bow rollers) max. 135mm/s (3 bow rollers) *
Machine speed:	max. 180m/min (max. 150m/min with fabric tension control)

HMI

Panel Type:	12" touch screen coloured
Ambient temperature:	-10°C to +60°C
IP classification:	IP 65 (front); IP 20 (back)
Power supply:	24V DC
Display:	1280x800 pixel

Fabric tension control

Pneumatic swing mechanism:	0-6 bar *
LoadCell:	0-750N *

SD Series 300 with CAM

Measuring range:	2....75 picks/cm (CAM Standard)
Ambient temperature:	max. 55°C
IP classification:	IP 64
Measuring accuracy pick/course density:	better than ± 1% from the measured value but not better than ± 0,1 Fd/cm.
Measuring accuracy skew / bow:	better than ± 0,1% from the measured value

Options:*



PLEVA GmbH
Rudolf-Diesel-Str. 2
D-72186 Empfingen-Germany
Tel: +49 (0) 7485 1004
Fax: +49 (0) 7485 1009
info@pleva.org www.pleva.org

