

PRE-CONSTRUCTION MEETING MANUAL

SPEC-BRIK®
Korfil® Hi-R and Hi-R H
and other Architectural
Concrete Masonry Projects

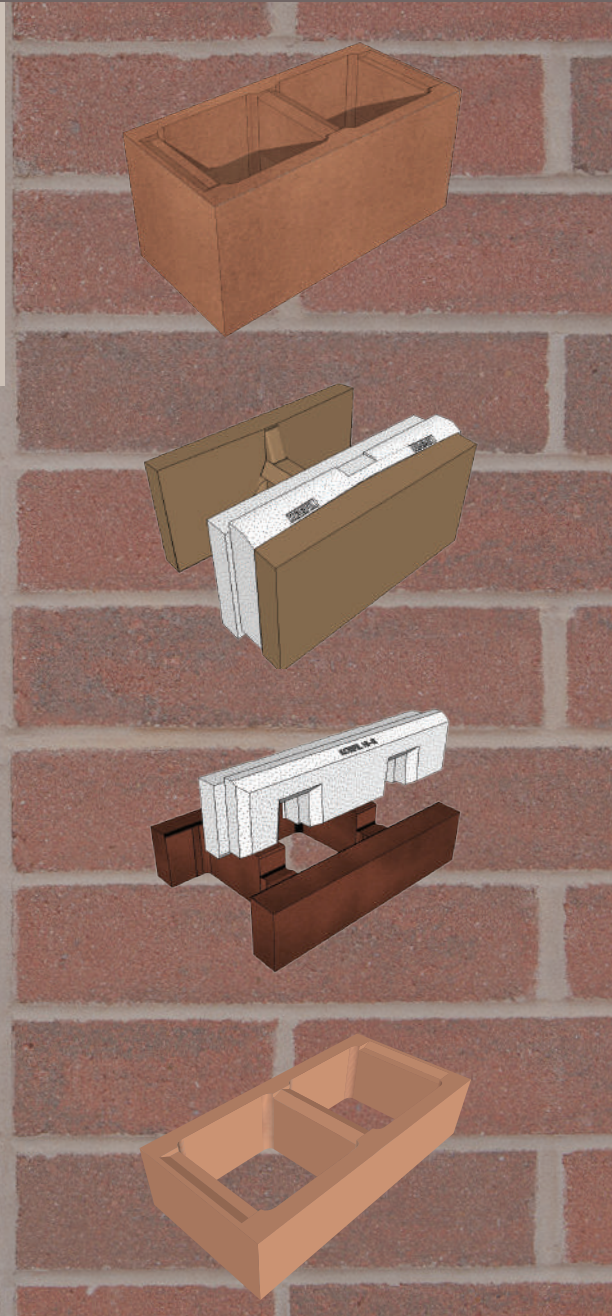

CONCRETE PRODUCTS GROUP

INNOVATIVE CONCRETE MASONRY SYSTEMS



Masonry Pre-Construction Meeting Guidelines

The Concrete Products Group provides videos that demonstrate each of the following suggested topics:



Sample Panel

The Sample Panel provides the basis for acceptance of the finished wall and should demonstrate all masonry materials and features, the mortar color(s) flashing and weep installation, as well as the cleaning method and sealing treatment. During the pre-construction meeting, the parties should go over how the sample panel will be constructed and the approval process for both the panel and the finished walls.

Installation of Flashing and Weeps

The installation methods for the specified flashing and weep system should be discussed as part of the pre-construction meeting, including discussing the features unique to proprietary systems such as Block-Flash. A video is available to demonstrate the proper installation techniques for this system.



Water Control Technology (WCT)

If WCT units are specified on the project, the manufacturer's representative should demonstrate the correct method of installation of the WCT units, including demonstrating how the units should be placed so that the WCT drainage features are on top so that they can assist in allowing drainage water to fall through the unit cores to the flashing and weep system where it can exit the wall.



Protecting Masonry Materials and the Wall Under Construction

Materials should be stored on pallets and protected from staining while on the site prior to installation. The walls under construction should also be protected from mud spattering and should be fully covered (tarping the top of the wall) during breaks in construction until they are permanently capped and flashed. Leaving the wall tops uncovered during construction allows rain to enter the cores in the masonry which can result in increased staining and efflorescence formation.

Proper Cleaning of Architectural Concrete Masonry Units

The meeting should discuss both the correct method of cleaning architectural concrete masonry and the timing of when cleaning should occur.

Here is a quick list of points to cover:

- Clean off mortar and grout stains as the wall is built to keep post construction cleaning to a minimum.
- Protect the masonry materials and unfinished walls from mud splatters and water intrusion during construction. Water left in cores of partially constructed masonry walls can lead to efflorescence, especially if the wall lacks a flashing and weep system. Cover the wall when work is interrupted until the wall is capped to prevent this.
- Clean architectural masonry walls before mortar and grout stains have had a chance to harden. Typically best results will be obtained by cleaning the walls after the mortar has had a chance to set up within 4 to 7 days of laying the masonry units.
- Use the gentlest cleaning method available, including using just plain water and a nonmetallic brush. If chemicals are used, use a masonry cleaner that has been proven successful with architectural concrete masonry. Follow the manufacturer's recommendations, but in general, the process should include pre-soaking the wall with water thoroughly prior to application, and thoroughly removing the cleaning agent by rinsing the wall completely and promptly after application.
- Always demonstrate the Cleaning means and methods on the sample panel first and obtain acceptance of those methods before applying them to the building.



Application of Post-Applied Sealers

- Application of the sealant should be demonstrated and accepted on the sample panel prior to application on the main walls.
- It is important not to apply a sealer until the walls have been cleaned, allowed to dry, and the cleaning results have been approved. If water repellents are applied onto walls with significant stains, the stains will still be visible after the coating has been applied.
- It is difficult to go back and re-clean sealed masonry as the sealer must be stripped off the wall first, a difficult task to accomplish without damaging the masonry.



Color Blends

The parties should also address how units with blended colors should be placed to assure the right mix of color blends in each section of the finished wall.

This should be demonstrated in the sample panel, which will serve as the basis for acceptance of the finished wall.



Questions?

For more information, visit
concreteproductsgroup.com
 or email your questions to
info@concreteproductsgroup.com

Construction Best Practices Check List for Spec-Brik® Projects

Storage and Handling of Masonry Materials

- **Minimize on-site storage time.**
Concrete Masonry Units should be laid in the wall as soon as possible after delivery. Staging deliveries so that masonry materials are not left unused on the job site for prolonged periods will help avoid discoloration and/or staining due to site conditions or prolonged weathering on the pallet.
- **Cover and Protect the Units Prior to Installation.**
Concrete Masonry Units should be stored on pallets and covered at all times prior to installation to prevent exposure to rain, snow or job site staining from mud or other materials. This will help prevent the formation of efflorescence. Once the units are removed from covered storage, they should not be exposed to water or soil.

Installation of Masonry Units

- **Job Site Sample Panel.**
Always Construct and Use a Job Site Sample Panel. The Sample Panel is required by the specification and Code, and provides the basis for acceptance of the finished wall. It should demonstrate all masonry materials and features to be used on the project, the mortar color(s), flashing and weep installation as well as the cleaning method and sealing treatment. During the pre-construction meeting, the parties should go over how the sample panel will be constructed and the approval process for both the panel and the finished walls. The use of a sample panel is a powerful tool to assure best results.
- **Protect the Walls from Rain During Construction.**
Cover all uncapped masonry walls or exposed masonry structures to protect them during breaks in construction and/or rainfall. The cause of efflorescence in masonry walls is exposure to water, which results in the water leaching salts from the masonry, forming a white stain on the walls. Leaving uncapped walls unprotected is one of the leading causes of efflorescence since the cavities in the wall collect rainwater. This can easily be avoided by tarping the walls so that they are protected from rain.
- **Use a Suitable Integral Water Repellent in the Mortar.**
SPEC-BRIK units contain integral water repellent admixture, and require the use of a chemically matched integral water repellent admixture in the mortar mix, which should be found in the job specification. The use of IWR in the mortar is critical for weather protection. If you need additional guidance on compatible mortar admixtures, consult your CPG manufacturer.
- **For Blended Colors, Lay the Units so that the Colors are Evenly Mixed and No Single Color Dominates Portions of the Wall.**
Important: distribute the range of color evenly throughout the wall. Pull and mix colors from different cubes and work from top to bottom of the cube as shown to the right.
- **Flashing and Weeps**
Be sure to follow the specification requirements for flashing and weep placement. For veneers, a suitable flashing and weep system should be placed at any interruptions in the drainage path in the wall's cavity. Proper flashing and weep design will allow water to drain out of the wall so that it will not be left in the wall to cause efflorescence stains.
- **Tooling Joints**
Tool joints when mortar reaches "thumb-print hardness" and be consistent about this. If a joint is tooled too soon, shrinkage cracks at the mortar/block interface are likely to occur and the final mortar color may be very light. If the joint is tooled too late the color becomes very dark and the mortar may not be plastic enough to seal properly against the masonry units. If wall sections are tooled when the mortar is at inconsistent degrees of hardness, the overall look of the wall will be significantly affected by the resulting differences in mortar color. Use a concave joint to avoid collection of moisture at the mortar joints.
- **Cutting Units**
Cutting Concrete Masonry Units will result in the formation of concrete dust on the units which can form stains that are very difficult to remove if left on the units after sawing is completed. Use a dry saw for masonry cuts and remove the residue prior to placing the units. A dustless saw will avoid dust formation

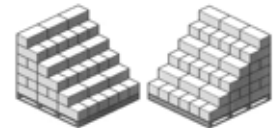

Cleaning Concrete Masonry

- **Remove Stains from the Wall.**

Concrete Masonry Units must be cleaned by removing mortar droppings, mortar splatters and efflorescence. **Demonstrate Cleaning Methods on the Sample Panel First to Avoid Risk of Damage to the Main Walls if the Method is wrong.** Then do a test section on an inconspicuous location on the walls before doing the entire wall. Cleaning results should be evaluated after the walls have dried. There are reputable cleaning products that are available to clean concrete masonry that will perform well if used properly. These include Light Duty Concrete Cleaner from Prosoco and NMD-80 from EaCo Chem. While they can be effective, they require careful use to avoid having the cleaning process itself cause damage to the wall's texture or colors.

- **Plan Ahead to Have Water Available When You Will Need it.**

Make sure at the Pre-Construction Meeting that there will be a source of water at the site available when cleaning needs to occur. All that is needed is a source of water that has typical water pressure for a garden hose - about 40-50 psi. Delaying cleaning due to a lack of water will make cleaning more difficult, as discussed below.

- **Follow Cleaning product Manufacturer's Recommendations and these guidelines.**

Follow the Manufacturer's application recommendations for concrete brick regarding recommended concentrations and application methods with these additional considerations:

- **Clean the Walls Promptly - For Best Results, Between 7 and 14 days after installation.**

This will make cleaning the units much easier, which will avoid the need for aggressive brushing or repeated applications of the cleaning agent to persistent stains, reducing the chance of damage to textures and colors. The longer mortar stains are left on the wall, the more bonded and difficult to remove they become.

- **Only Use Low Water Pressure for Applying the Cleaner and Rinsing it Off - 50 psi or Less.**

Use of pressure washers set at high pressure to clean walls is extremely risky due to multiple problems this practice will cause. These include: (1) the formation of post-cleaning efflorescence by driving water under high pressure into the concrete masonry, and (2) defacing the wall with wand marks and altering the texture and color of the wall. High pressure washing will actually scour the cement paste off of the surface of the wall, particularly when used to rinse off an acid based cleaner, and in extreme cases this can compromise the wall's ability to resist moisture penetration. **You should never use more water pressure than you could tolerate if the water stream were directed at your hand.**

- **As a Rule, Use the Gentlest method possible.**

Bear in mind that masonry walls, when soaked with acid-based cleaners, are vulnerable to damage. As a result, aggressive use of chemical cleaners and/or abrasives and/or high water pressure will leave stains and scars that will diminish the beauty of the wall after it has dried and should be avoided in all circumstances.

Post-Applied Sealants

- **Benefits of Post-Applied Clear Breathable Water Repellent Sealants.**

A suitable post-applied water repellent sealant will provide extra weather protection to the wall system and will assist with efflorescence control by protecting the wall from moisture penetration. Select a sealant that is clear and will not alter wall coloration. In addition, the sealant must be breathable. Finally, seek out sealants that offer protection against moisture penetration even in the event of cracks in the wall. Some sealants will offer protection even against cracks of up to 1/16" in size.

- **Make sure all stains have been removed from the walls before application.**

Application of the sealant to the wall will make removal of any remaining efflorescence or mortar stains very difficult to accomplish as the sealant will need to be removed. This is likely to result in damage to the walls aesthetics.

- **Be Careful Regarding Potential Color Alteration from Certain Post-Applied Coatings.**

Sacrificial Anti-Graffiti Coatings may significantly darken the wall surface and add a shiny texture to them, which likely will be undesirable from an aesthetic standpoint. In addition, silicone based sealants are likely to darken the walls. **Always test surface treatments on the sample panel prior to application to the main walls to avoid undesirable results.**

- **Avoid plugging the drainage weeps during application of post-applied coatings.**

This is a particular risk with paints - make sure the weep holes are unimpeded after application to assure that they will function properly.

I have reviewed the best practices checklist and will use them on this project:

Contractor: _____

By _____

Its authorized representative

Construction Best Practices Check List for Spec-Brik® Veneer Projects

Storage and Handling of Masonry Materials

- **Minimize on-site storage time.**
Concrete Masonry Units should be laid in the wall as soon as possible after delivery. Staging deliveries so that masonry materials are not left unused on the job site for prolonged periods will help avoid discoloration and/or staining due to site conditions or prolonged weathering on the pallet.
- **Cover and Protect the Units Prior to Installation.**
Concrete Masonry Units should be stored on pallets and covered at all times prior to installation to prevent exposure to rain, snow or job site staining from mud or other materials. This will help prevent the formation of efflorescence. Once the units are removed from covered storage, they should not be exposed to water or soil.

Installation of Masonry Units

- **Job Site Sample Panel.**
Always Construct and Use a Job Site Sample Panel. The Sample Panel is required by the specification and Code, and provides the basis for acceptance of the finished wall. It should demonstrate all masonry materials and features to be used on the project, the mortar color(s), flashing and weep installation as well as the cleaning method and sealing treatment. During the pre-construction meeting, the parties should go over how the sample panel will be constructed and the approval process for both the panel and the finished walls. The use of a sample panel is a powerful tool to assure best results.
- **Protect the Walls from Rain During Construction.**
Cover all uncapped masonry walls or exposed masonry structures to protect them during breaks in construction and/or rainfall. The cause of efflorescence in masonry walls is exposure to water, which results in the water leaching salts from the masonry, forming a white stain on the walls. Leaving uncapped walls unprotected is one of the leading causes of efflorescence since the cavities in the wall collect rainwater. This can easily be avoided by tarping the walls so that they are protected from rain.
- **Use a Suitable Integral Water Repellent in the Mortar.**
SPEC-BRIK units contain integral water repellent admixture, and require the use of a chemically matched integral water repellent admixture in the mortar mix, which should be found in the job specification. The use of IWR in the mortar is critical for weather protection. If you need additional guidance on compatible mortar admixtures, consult your CPG manufacturer.
- **For Blended Colors, Lay the Units so that the Colors are Evenly Mixed and No Single Color Dominates Portions of the Wall.**
Important: distribute the range of color evenly throughout the wall. Pull and mix colors from different cubes and work from top to bottom of the cube as shown to the right.
- **Flashing and Weeps**
Be sure to follow the specification requirements for flashing and weep placement. For veneers, a suitable flashing and weep system should be placed at any interruptions in the drainage path in the wall's cavity. Proper flashing and weep design will allow water to drain out of the wall so that it will not be left in the wall to cause efflorescence stains.
- **Tooling Joints**
Tool joints when mortar reaches "thumb-print hardness" and be consistent about this. If a joint is tooled too soon, shrinkage cracks at the mortar/block interface are likely to occur and the final mortar color may be very light. If the joint is tooled too late the color becomes very dark and the mortar may not be plastic enough to seal properly against the masonry units. If wall sections are tooled when the mortar is at inconsistent degrees of hardness, the overall look of the wall will be significantly affected by the resulting differences in mortar color. Use a concave joint to avoid collection of moisture at the mortar joints.
- **Cutting Units**
Cutting Concrete Masonry Units will result in the formation of concrete dust on the units which can form stains that are very difficult to remove if left on the units after sawing is completed. Use a dry saw for masonry cuts and remove the residue prior to placing the units. A dustless saw will avoid dust formation.
- **Horizontal Joint Reinforcement**
Follow industry recommendations for horizontal joint reinforcement in concrete masonry veneer. Typically this will mean spacing the joint reinforcement at 12" o.c. for 4" high veneers, and 16" o.c. for 8" high veneers.

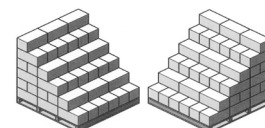

Cleaning Concrete Masonry

- **Remove Stains from the Wall.**

Concrete Masonry Units must be cleaned by removing mortar droppings, mortar splatters and efflorescence without damaging the masonry. **Demonstrate Cleaning Methods on the Sample Panel First to Avoid Risk of Damage to the Main Walls if the Method is wrong.** Then do a test section on an inconspicuous location on the walls before doing the entire wall. Cleaning results should be evaluated after the walls have dried. There are reputable cleaning products that are available to clean concrete masonry that will perform well if used properly. These include Light Duty Concrete Cleaner from ProsoCo and NMD-80 from EaCo Chem. While they can be effective, they require careful use to avoid having the cleaning process itself cause damage to the wall's texture or colors.

- **Plan Ahead to Have Water Available When You Will Need it.**

Make sure at the Pre-Construction Meeting that there will be a source of water at the site available when cleaning needs to occur. All that is needed is a source of water that has typical water pressure for a garden hose - about 40-50 psi. Delaying cleaning due to a lack of water will make cleaning more difficult, as discussed below.

- **Considerations in developing the cleaning method**

Use the Manufacturer's application recommendations for concrete brick regarding application methods with these additional considerations:

- **Clean the Walls Promptly - For Best Results, Between 7 and 14 days after installation.**

This will make cleaning the units much easier, which will avoid the need for aggressive brushing or repeated applications of the cleaning agent to persistent stains, reducing the chance of damage to textures and colors. The longer mortar stains are left on the wall, the more bonded and difficult to remove they become.

- **Only Use Low Water Pressure for Applying the Cleaner and Rinsing it Off.**

Use of pressure washers set at high pressure to clean walls is extremely risky due to multiple problems this practice will cause. These include: (1) the formation of post-cleaning efflorescence by driving water under high pressure into the concrete masonry, and (2) defacing the wall with wand marks and altering the texture and color of the wall. High pressure washing will actually scour the cement paste off of the surface of the wall, particularly when used to rinse off an acid based cleaner, and in extreme cases this can compromise the wall's ability to resist moisture penetration. **You should never use more water pressure than you could tolerate if the water stream were directed at your hand.**

- **Use the Gentlest method possible.**

Bear in mind that masonry walls, when soaked with acid-based cleaners, are vulnerable to damage. As a result, aggressive use of chemical cleaners and/or abrasives and/or high water pressure will leave stains and scars that will diminish the beauty of the wall after it has dried and should be avoided in all circumstances. **It may be wise to test reducing the concentration of the cleaner below manufacturer's recommendations (for example, using a 6 to 1 ratio rather than a 4 to 1 ratio) to get good results without risking damage to the wall.**

Post-Applied Sealants

- **Benefits of Post-Applied Clear Breathable Water Repellent Sealants.**

A suitable post-applied water repellent sealant will provide extra weather protection to the wall system and will assist with efflorescence control by protecting the wall from moisture penetration. Select a sealant that is clear and will not alter wall coloration. In addition, the sealant must be breathable. Finally, seek out sealants that offer protection against moisture penetration even in the event of cracks in the wall. Some sealants will offer protection even against cracks of up to 1/16" in size.

- **Make sure all stains have been removed from the walls before application.**

Application of the sealant to the wall will make removal of any remaining efflorescence or mortar stains very difficult to accomplish as the sealant will need to be removed. This is likely to result in damage to the walls aesthetics.

- **Be Careful Regarding Potential Color Alteration from Certain Post-Applied Coatings.**

Sacrificial Anti-Graffiti Coatings may significantly darken the wall surface and add a shiny texture to them, which likely will be undesirable from an aesthetic standpoint. In addition, silicone based sealants are likely to darken the walls. **Always test surface treatments on the sample panel prior to application to the main walls to avoid undesirable results.**

- **Avoid plugging the drainage weeps during application of post-applied coatings.**

This is a particular risk with paints - make sure the weep holes are unimpeded after application to assure that they will function properly.

I have reviewed the best practices checklist and will use them on this project:

Contractor: _____

By _____

Its authorized representative

HI-R and HI-R-H Construction Best Practices

The following tips should be used for best results when building walls using Hi-R and Hi-R H Wall Systems.

- 1. Unit and Mortar Dimensions.** The Hi-R and Hi-R H systems are designed to use a 3/8" mortar joint, head and bed. The units are 1/8" taller at the inside of the face shell (7-3/4") than at the face (7-5/8") so less mortar will be required for the bed joints than conventional CMU.
- 2. Install the Units "Right Side Up".** Korfil Hi-R/Hi-R-H Units are pre-insulated at the manufacturer and will arrive at the job site with the insulation in place. Unlike standard CMU, these units are not inverted for installation. When the units are correctly oriented, the insert will rest on top of the webs as shown below.

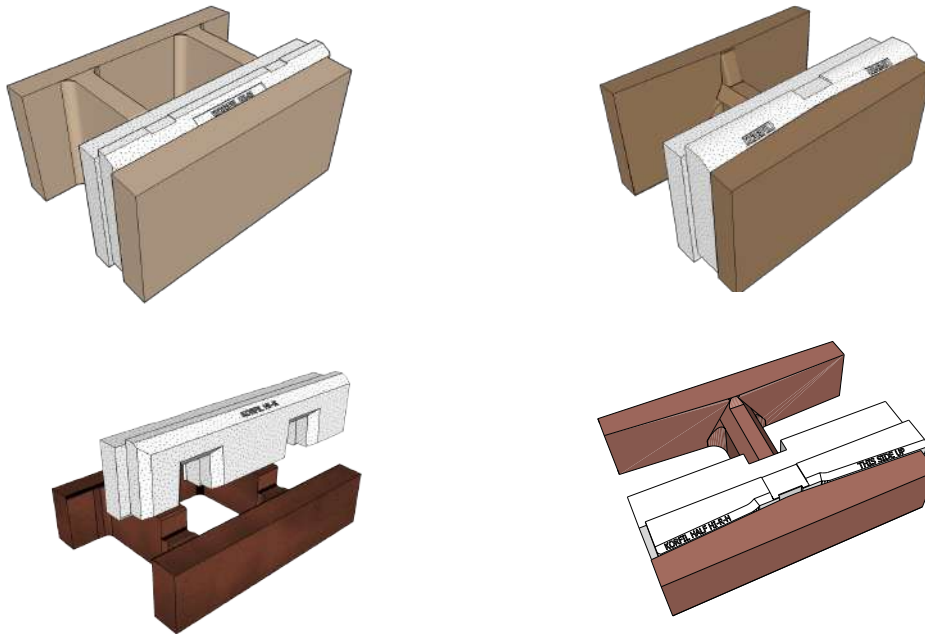

- 3. Locate Insulation Inserts toward the Exterior of the Wall.** Typically the blocks should be oriented so that the inserts are located toward the exterior of the wall, as shown below. If your plans indicate a different orientation, check with the designer to confirm that it was intentional.

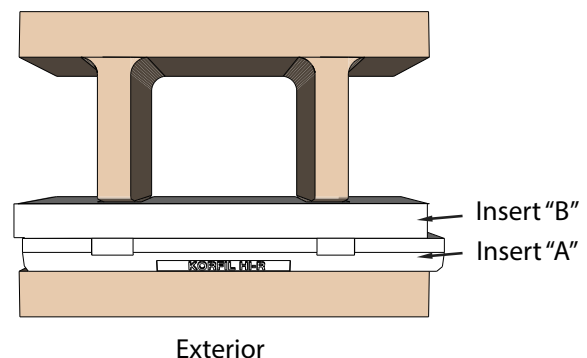

- 4. After Laying Block, Tap Insert Into Place.** You will notice that the inserts have two interlocking parts which are referred to as the "A" insert (located toward the exterior of the block) and the "B" Insert (located toward the interior of the block). The inserts are designed to form lapping joints when placed in the wall both with blocks located above and below and to both sides to provide superior insulation. As you build each course, be sure to tap or push the "B" Insert downwards to position it correctly to form a tight joint with the inserts below. At the end of each work day, make sure the "B" Inserts on the top course are tapped down into



place to avoid a height gain when work is recommenced due to excess mortar getting Handling Inserts on the Starter Course. Either carefully avoid leaving excess mortar under the "B" insert or remove the "B" insert on the starter course. This is done to make certain any mortar that may have fallen under the inner insert does not prevent inserts on the next course from being pushed downward.

5. Grouting and Reinforcing Hi-R and Hi-R H Walls. The Hi-R product is suitable for both full and partial grouting. The Hi-R H products is designed for only for fully grouted walls. The webs in Hi-R blocks will align when they are placed in either a running bond or stack bond pattern providing an unobstructed cavity for grouting and re-bar placement. The reduced height of the Hi-R H single web will allow grout to flow between units and is suitable for fully grouted walls in either running or stack bond patterns. When building partially grouted Hi-R Walls, request that the webs be full height. This will eliminate the need to mortar the reduced height webs. under the insert and hardening.

Grout Information

Unit	Grout volume per unit (cubic inches)	Grout ft ³ per ft ² of wall area (fully grouted)
Hi-R 8-8-16 Smooth	215.2 in ³	.140 ft ³
Hi-R 8-8-16 Split	215.2 in ³	.140 ft ³
Hi-R 10-8-16 Smooth/Split	398.8 in ³	.260 ft ³
Hi-R 12-8-16 smooth/split	582 in ³	.379 ft ³
Hi-R-12-4-16	291 in ³	.379 ft ³
Hi-R-H 12-8-16 Smooth	551 in ³	.358 ft ³
Hi-R-H 12-8-16 Split	551 in ³	.358 ft ³
Hi-R-H 10-8-16 smooth	325 in ³	.211 ft ³
Hi-R-H 10-8-16 split	325 in ³	.211 ft ³
Hi-R-H 12-4-16	241.5 in ³	.315 ft ³
Hi-R-H 12-4-16 Jamb unit	182.1 in ³	.237 ft ³

6. Building Bond Beams. For Korfil Hi-R units, check with your local manufacturer for available bond beam units. For Hi-R H units, the standard Hi-R H unit may be used as a bond beam unit without the need for any modifications.

7. Anticipate Vertical Rebar Placement. Provide the General Contractor information on the proper spacing and location for vertical rebar placement in grade beam to avoid having to bend rods or cut block.

8. Horizontal Joint Reinforcement Placement. The Hi-R and Hi-R H Systems work with 9-gauge Ladder Type Wall Reinforcing with butt welded center cross ties at 16 inch increments. The ties should be placed directly over webs of blocks to allow the innermost insert to be pushed down to lock with the insert below it.



9. **Corners.** These details can be constructed using specialty units (available regionally – check on availability) or standard masonry fittings and insulation.

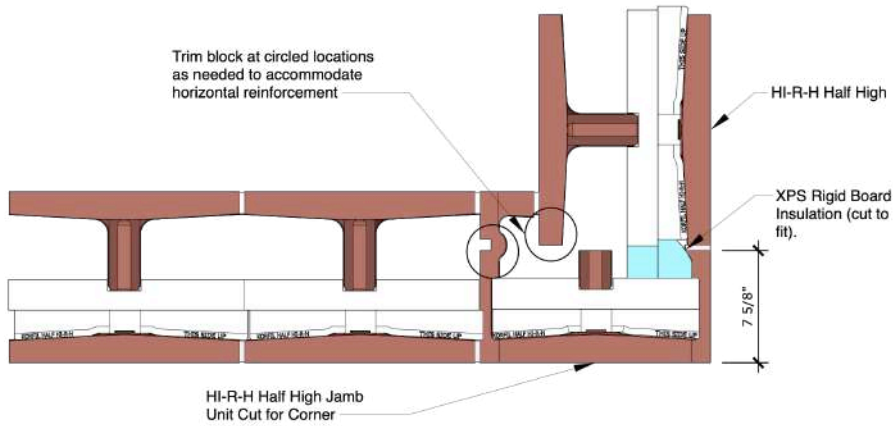

Corner Constructed Using Specialty HI-R-H Jamb and Corner Unit

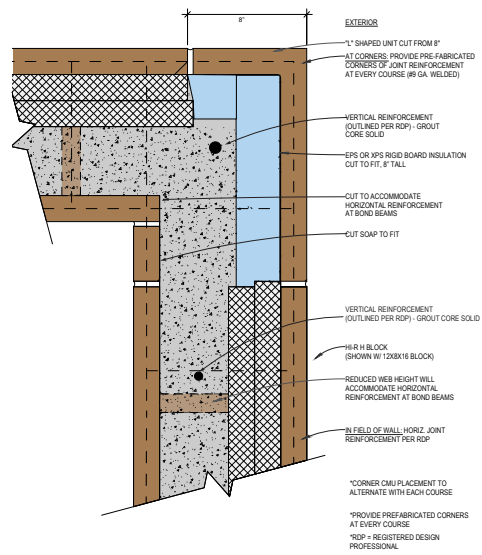

Corner Constructed Using Concrete Masonry Unit Fittings



10. Joints and Jamb. These details can be constructed using specialty units (available regionally or standard masonry fittings and rigid insulation). The HI-R-H Jamb and Corner Unit is only available in some regional markets – please check availability before specifying.

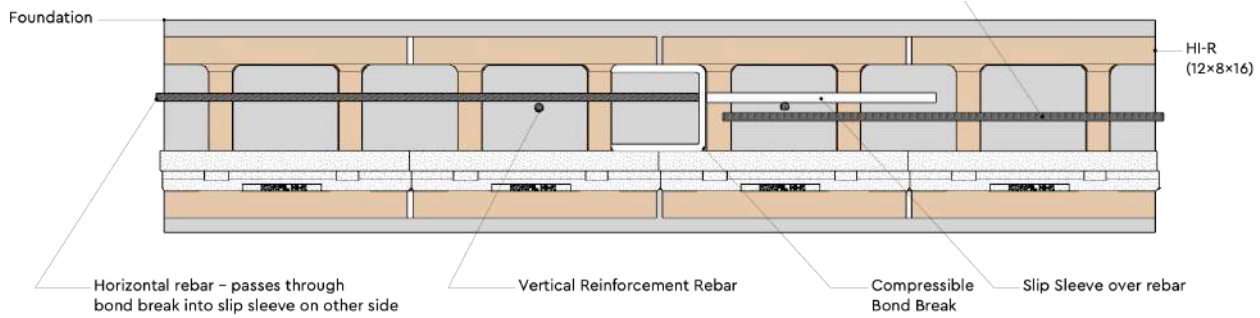
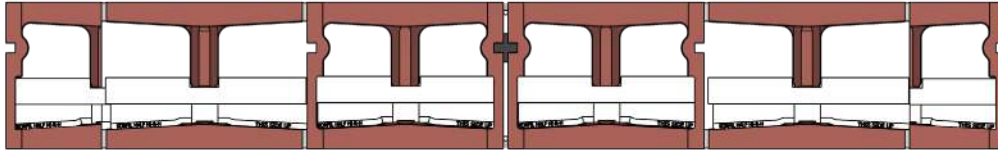

Michigan Style Soft Joint Constructed Using HI-R Units
(Not Feasible with HI-R-H style units)

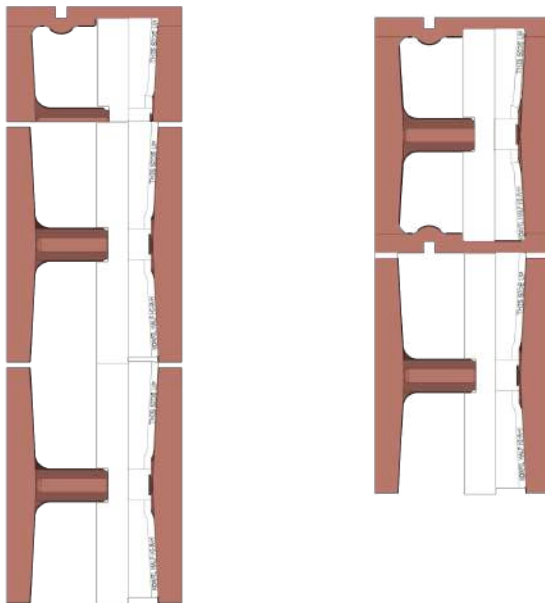

Jamb – Alternate Courses Constructed with HI-R-H/Hi-R-H Half High Jamb Unit



11. **Avoid Chippage.** Care should be taken in job site handling to avoid chippage and breakage. Your forklift operator should exercise caution on rough terrain.
12. **Loadbearing Points.** Delete inserts at load-bearing points directly under bar joist, pre-cast beams, etc. Consult your project architect and engineer for approval
13. **Store or Dispose of Loose Inserts.** Since the inserts are relatively light and can be moved by wind, collect and secure any loose inserts on the job site.
14. **Architectural Masonry Construction Best Practices.** For Architectural Masonry, please refer to "Spec-Brik® Construction Best Practices" available from Concrete Products Group LLC.

Questions?

*For more information, visit
concreteproductsgroup.com
or email your questions to
info@concreteproductsgroup.com*



Building and Using Sample Panels



The jobsite sample panel is a commitment by the construction team to the quality that must be delivered to the building owner. Masonry sample panels are required by Code and simply are the best way to set the standard for acceptance of the finished work. When a sample panel has been built and accepted, everyone is protected from misunderstandings that can be frustrating and disputes that can be expensive. Simply following industry standards on the use of a sample panel is a great way to assure that your project will be successful.

Sample Panel Defines Project Quality

The jobsite sample panel is the single most important tool to control the quality of the masonry walls. After it is approved, the sample panel is a point of reference of how the walls are expected to be built and look at the completion of the project.

Mortar tooling, cleaning, and coatings are all demonstrated on the sample panel. Masons can confirm their means and methods are acceptable before it is too late and the walls are built.

After the architect approves the jobsite sample panel, managers can use the sample panel as a daily reminder for their crew on the quality they committed to build. The general contractor and jobsite inspector have a visual reference of what the specifications require, what the mason agreed to provide and the architect approved as acceptable.

QUICK POINTS

- The Jobsite Sample Panel is the best tool to assure wall quality
- The accepted sample panel provides a visual reference for the ongoing work on the project
- The sample panel is not used for masonry color selection – that should be completed prior to construction of the panel.
- Every important aspect of the finished wall is demonstrated on the sample panel first.
- The sample panel is a great way to test cleaning methods and post-applied coatings without risk to the walls.

Specifying and Building the Sample Panel

In general, the designer should follow the requirements of the most current edition of the “Building Code Requirements and Specification for Masonry Structures”

The jobsite sample panel must be constructed and approved before the masonry work begins on the project. All samples and submittals except the mortar color must be approved before the jobsite sample panel is constructed.

Mortar joint color and tooling greatly influence the finished appearance of the wall and must be approved in the sample panel, and tooled by the mason contractor selected for the project.

Construct the sample panel on the jobsite at a highly visible location where it will not be disturbed before the completion of this project. Use only the materials that were approved in the submittal review and masonry units that were already manufactured for this project.

The contractor should place orders for jobsite sample panel materials with masonry producers so that they have advance notice to manufacture and collect the full range of color for the building for shipment on a separate pallet.

The minimum size of the sample panel dimensions must be at least 4 ft. by 4 ft. A larger panel may allow more options to test cleaning and sealing. One approach is to build a sample panel that is 4ft by 8ft in order to demonstrate how the wall looks both before and after cleaning and surface treatments.

The purpose of jobsite sample panel is to show the acceptable standard of work for the project and it must include:

1. The full range of masonry unit color and texture that will be visible in the finished walls.
2. Bond pattern and color pattern if masonry units of more than one color are being used.
3. Chippage dimensions and frequency including dimensional variation per project specifications.
4. Mortar joint size, tooling, alignment, texture and color range.
5. If colored mortar is used, the color must be judged after the sample panel has had sufficient time to dry.
6. Installation of flashing, weeps, drip edge and sealant joint.
7. Movement joint installation and sealant joint
8. Cleaning means and methods.
9. Surface treatments such as breathable sealants.



The sample panel will be used for final acceptance of the masonry work and must remain unharmed until the masonry is complete and accepted. The Masonry Code charging language states:

“The acceptable standard for the Work is established by the accepted panel.”

The sample panel will be viewed from a distance of 20 feet away under diffused lighting to evaluate the results.

Conclusion

Simply following industry standards on the use of a sample panel is a great way to assure that your project will be successful.



Questions?

For more information, visit concreteproductsgroup.com or email your questions to info@concreteproductsgroup.com

Protecting Masonry Materials and Walls During Construction



To assure best results when building with architectural masonry, taking a few simple steps at the jobsite to protect the masonry materials and walls during construction (and after completion of the masonry work) will help deliver great results at less expense.

Protect Masonry Materials Stored on Site

Units should be stored on pallets, and not directly on the ground. They should be adequately covered to prevent water absorption or staining from mud or other materials on the site.

Staging deliveries so that masonry materials are not left unused on the jobsite for prolonged periods can also be helpful in avoiding discoloration or staining due to site conditions or prolonged weathering on the pallet.

Once the units are removed from covered storage, they should be handled so that they are not exposed to water or soil. The wall under construction should be protected from mud splatters or other conditions that could result in staining.

QUICK POINTS

Taking steps to protect the masonry from staining will produce better results and less expense.

Keep stored materials covered and clean.

Cover uncapped walls or exposed details during construction to avoid water penetration and consequent efflorescence.

Protect the wall from water infiltration until permanent capping has been installed

Prevent Water Penetration into the Walls During Construction

At the end of the workday, and after completing each segment of the masonry wall, the top surface of the masonry must be protected to prevent water penetration. Use a plastic tarp to cover the unfinished masonry work to protect it from the weather. Cap the walls as soon as possible after building them. Uncovered masonry walls are vulnerable to large quantities of water entering the wall during rainstorms, which can lead to the formation of efflorescence – especially if the wall does not have a proper flashing and weep system installed. This advice also applies to uncapped columns or other details.



Protect the Wall After Masonry Construction is Complete Until a Permanent Coping is in Place

The time between when the mason finishes installing the wall and when the roofing contractor permanently caps the wall is a period when staining problems occur most often. While it is required by code that the top of walls be protected from moisture entering until the permanent coping is in place, failing to protect the top of wall at this time has resulted in the most severe moisture related staining of the masonry.

One effective and simple way to ensure that completed walls remain covered after the mason has left the project, is to install an inexpensive membrane at the top of the wall upon completion. Flexible flashing materials such as EPDM are inexpensive, can be glued to the top of the wall and left in place below the blocking when the permanent coping is installed. Bolts and embeds should be sealed to ensure moisture cannot enter the wall from the top. This simple step can prevent the majority of problems mason contractors typically encounter due to moisture related staining from uncovered walls.



Adhering a water resistive membrane to the top of the wall – this can be left in place when the roof is installed

Note on Fully Grouted Walls

While the collection area for water is not as obvious, fully grouted walls are equally vulnerable to efflorescence formation if left unprotected. A capped fully grouted wall will be an effective barrier wall if built with integral water repellent in the block and mortar, and preferably having a post-applied sealer applied to the exterior of the walls. Leaving the top of a fully grouted wall exposed to weather, however, is likely to produce bad results. If left exposed, the grouted cores will absorb rainwater. Unlike a partially grouted wall, where a flashing and weep system allows drainage, the fully grouted wall will store the water for a longer period of time and as the water migrates to the surface of the wall, this may result in efflorescence. As a result, we recommend that the same degree of care be exercised to protect the top of a fully grouted wall from rain using the methods described above.



*Top of wall protection partially removed by roof contractor prior to permanent coping installation
- note efflorescence formation*



Questions?

For more information, visit
concreteproductsgroup.com
or email your questions to
info@concreteproductsgroup.com

RainBloc®

Integral Water Repellent System for Concrete Masonry

Concrete masonry constructed with the ACM Chemistries® RainBloc® Integral Water Repellent System resists rainwater penetration because

- individual masonry units incorporate the RainBloc® water repellent additive during their manufacture
- concrete masonry units are tested and certified for water repellency performance compliance
- masonry mortar is produced with the RainBloc® for Mortar water repellent additive at the construction site

Concrete masonry produced with the RainBloc® Integral Water Repellent System resists wind-driven rain while still maintaining vapor transmission, reducing the chance of mold, mildew, and musty smells from developing inside a building.

Benefits of the RainBloc® System

Masonry constructed using the RainBloc® System

- resists rain water penetration
- fights against mold and mildew
- maintains masonry colors
- resists efflorescence

RainBloc® System Features

The RainBloc® system improves water penetration resistance because it's

- polymeric-based
- permanent
- durable for the life of the masonry structure
- a full-wall thickness water penetration protection system

RainBloc® "Anti-Wicking" Feature

Untreated concrete masonry units readily absorb water through a process called capillary suction or "wicking action".

The RainBloc® anti-wicking feature ensures that masonry units and mortar strongly resist water absorption. If rainwater seeps past the exterior face of the wall, the RainBloc® system's water repellent properties minimize the amount of water that can be absorbed into the concrete, causing any water inside the wall to flow to properly-installed wall flashing and weep holes.

RainBloc® Performance in ASTM Standards and Tests

RainBloc® test data earns excellent ratings. ACM Chemistries uses the most rigorous evaluation methods of the American Standards for Testing and Materials (ASTM). Masonry produced with the RainBloc® system performs exceedingly well in E 514-74, E 514-90, and ASTM E 96.

- ASTM E 514-74, "Standard Test Method for Water Permeance of Masonry." This aggressive standard exposes test walls to simulated, wind-driven rain for 72 hours, exposing them to the equivalent of 5½ inches of rain per hour pushed toward the wall with a pressure equivalent to a 62½ mile per hour wind, and then uses a grading system to rank wall performance, from "L" for "leakage" to "E" for "excellent".
- By comparison, the 1990 version of ASTM E-514 (E 514-90), "Standard Test Method for Water Penetration and Leakage through Masonry," requires walls to be tested only for 4 hours, since most walls indicate their performance level within that period of time.
- Good water vapor transmission prevents moisture from staying trapped within the wall system, which can cause mold and mildew problems over time. While providing excellent rainwater penetration resistance, ASTM E 96, "Standard Test Methods for Water Vapor Transmission of Materials" shows that the RainBloc® system also maintains good water vapor transmission properties for concrete.

RainBloc® Complements Good Design and Construction

A complete water repellent system emphasizes proper masonry design, details, and implementation. Although the RainBloc® Integral Water Repellent System provides excellent rainwater penetration resistance, it should not replace proper flashing, weep holes, and control joints in masonry construction.

The designer must provide the mason contractor with detailed illustrations of adequate flashing, weep holes, and control joints.

RainBloc®

for Concrete Masonry Units - CMUs

RainBloc® for CMUs is a liquid admixture used in the production of concrete block to ensure water repellency. An automated dispensing system injects the RainBloc® liquid admixture into each mixture of concrete during the masonry unit manufacturing process.

Water Repellency Certification Using the RainBloc® Spray Bar Test Method

The RainBloc® Spray Bar Test Method subjects individual concrete masonry units to continuous water pressure from a standardized spray bar at a rate of 120 gallons of water per hour.

After four hours of continuous exposure, each unit is evaluated using standardized pass/fail criteria. This test method correlates well with ASTM E 514.

A producer's concrete masonry units must pass this rigorous test to be a certified RainBloc® producer.

Testing Procedure

1. Masonry units are manufactured with RainBloc® admixture with assistance from an ACM Chemistries technical service representative.
2. Masonry units are shipped to ACM Chemistries for evaluation using the RainBloc® Spray Bar Test Method.
3. Units are tested for compliance with the ASTM Unit Specification designated for the type of unit manufactured (ASTM C 55, C 90, C 129, or C 744).

Performance Report

The CMU producer receives a RainBloc® Certification Report upon successful compliance with the water repellency performance criteria established by ACM Chemistries, Inc. This report provides evidence to specifiers about the performance and certification of compliance for the water repellent units made by the manufacturer.

Each certified RainBloc® producer receives a performance report that includes

- RainBloc® Spray Bar Test Method results
- masonry unit physical properties
- certificate of performance

Daily Quality Assurance Testing

A selection of the daily production of water repellent masonry units must be tested for water repellency within 48 hours of manufacture, before they are exposed to dust and dirt. Concrete masonry units stored outdoors may become coated by dust and dirt, which prevents water from beading on the surface.

Note: Even when coated with dust and dirt, the concrete masonry units still should resist water absorption although water may not bead on the surface. In other words, the units are still highly water repellent.

An ACM Chemistries technical service representative is always available for assistance with setting up the testing program.

Maintaining Certification

Upon certification, a masonry unit producer must continue to meet the following conditions:

- Masonry unit producer certification is valid for one year from the date of certification.
- Should be certified every twelve months for each concrete mix design (excluding a change of pigmentation) used with RainBloc® in manufacturing water-repellent, concrete masonry units.
- Must be certified again for changes to the concrete mixture proportions or raw materials to stay in compliance.
- Simple, quality control procedures recommended by ACM Chemistries, Inc., must also be used by the RainBloc® certified producers to ensure that water repellency parameters are being met on a consistent basis. The producer, purchaser, and specifier can be confident that the water repellent units will effectively resist water penetration.

RainBloc® for Mortar

RainBloc® for Mortar is a liquid admixture used at the masonry construction site to make mortar. RainBloc® for Mortar should be used with all concrete or clay masonry units in exterior masonry wall construction.

RainBloc® for Mortar Performance in ASTM Standards and Tests

RainBloc® for Mortar meets or exceeds the performance requirements for high quality masonry mortar water repellents when tested and evaluated according to ASTM C 1384, "Standard Specification for Admixtures for Masonry Mortars".

When measured by ASTM C 1072, "Standard Test Method for Measurement of Masonry Flexural Bond Strength", the RainBloc® Integral Water Repellent System does not adversely affect mortar bond.

Testing RainBloc® for Mortar Selections for Quality Assurance

RainBloc® for Mortar's pre-measured containers make addition by the masonry contractor easy.

Directions appear on the side of each container and include the required amounts for each batch of mortar.

To verify the proper dosage for water repellency, the amount of RainBloc® for Mortar used per day should correlate with the number of mortar batches produced per day. This can be accomplished by counting the number of RainBloc® for Mortar containers used as well as the number of mortar batches produced each day. Your ACM Chemistries technical service representative is always available for assistance.

Technical Service and Support

ACM Chemistries employs the most knowledgeable and competent technical sales and support staff in the industry today.

Our knowledge of machine-made concrete products, including the material science and technology used to manufacture those products, helps us optimize quality and performance, while reducing manufacturing costs for our customers.

We make sure that our staff retains expertise in concrete and masonry technology and best practices for providing technical services to our customers and the industry.

Full-time, trained ACM Chemistries technical sales representatives are located in several regions to serve you.

We share your challenges, and, together, we will meet them with the best solutions.

Technical Service in CMU Production

ACM Chemistries technical service representatives work with each potential RainBloc® certified producer to determine the dosage of RainBloc® required for the specific manufacturing facility according to the following process:

1. ACM Chemistries technical service representatives work with the manufacturer's quality control and manufacturing staff to inspect and analyze the raw materials used by the manufacturer, including
 - cementitious material(s)
 - aggregates
 - equipment
2. An ACM Chemistries technical service representative recommends any necessary changes in raw materials or processes, as well as a range of RainBloc® dosage levels to be tried at the facility for RainBloc® Certification Compliance.
3. An ACM Chemistries technical service representative oversees and manages the process of concrete masonry unit manufacturing with the recommended dosage levels of RainBloc®.

The RainBloc® technical service representative selects and marks CMU's for water repellency testing to certify performance and ASTM masonry unit specification compliance. (See Water Repellency Certification Using the RainBloc® Spray Bar Test Method.)



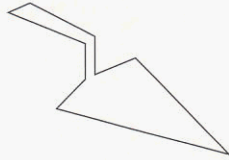

TROWEL TIPS

an aid to the masonry industry

Mortar Color

Introduction

Many factors are involved in the choice of masonry for use in a building. Certainly masonry offers advantages in durability, building safety, reliable structural performance, and low maintenance that appeal to the discriminating owner. However, a major consideration in selecting masonry is often an appreciation for its inherent beauty. That fact, coupled with the recent trend toward more dramatic architectural use of color and texture in building design, has resulted in greater emphasis on achieving the desired appearance in finished masonry mortar joints. This publication examines the factors that determine the color consistency of mortar joints and how certain construction practices and techniques relate to the final appearance of a mortar joint. The focus of this document is on steps that the mason can implement to assure that the appearance of mortar joints are acceptable to the owner.

Evaluating Appearance

While the statement "beauty is in the eye of the beholder" rightly points out that evaluation of appearance is subjective, there are certain general principles that are common to our perception of appearance. For example, texture and color are the primary criteria by which we categorize the appearance of mortar joints. These primary appearance criteria are further subdivided. Texture is evaluated subjectively on the basis smoothness or roughness, while colors are classified based on hue, intensity, and shade. Hue is that quality of color described in terms such as red and yellow. Intensity is the degree to which the hue dominates the color of an object, and shade refers to the relative lightness and darkness of an object. Our perception of the appearance of an object is also influenced by the light under which it is viewed and its immediate environment. Thus, two objects may appear to be identical in hue when viewed in direct sunlight, but exhibit perceptible differences when shaded or vice versa. An object viewed against an intensely colored background will be perceived as having a different color than the same object viewed against a neutral gray background. Perceived appearance is a complex interaction of all of these variables.

Acceptance of appearance is further complicated by the fact that individuals may subjectively place more emphasis on the selection and control of some of these variables than



(a) Different hues, same intensity and shade

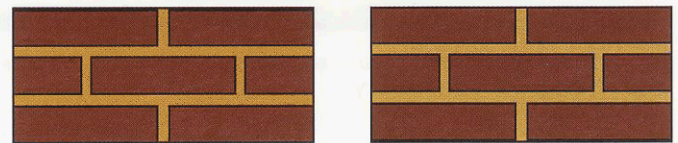

(b) Different intensities, same hue and shade



(c) Different shade, same hue and intensity

Fig. 1. Color can be classified on the basis of three variables: hue, intensity, and shade as illustrated by these examples in which two of the variables are held constant while two distinct levels were selected for the third variable.

others. For example, one individual may primarily be concerned that a certain hue is achieved while another may place approximately equivalent value on obtaining desired texture and hue. Therefore, achieving acceptable appearance of mortar joints on a project requires: 1) initial agreement between the owner or his representative and the contractor or mason on what constitutes desired appearance, 2) an understanding by both of the inherent limitations of the system, and 3) careful control of influencing variables by the contractor and mason.

Several systems have been developed to measure and categorize the appearance of different objects. These range from complex procedures utilizing instrumental measurement techniques to simple guidelines for the comparative viewing of objects. While the former may have merit when used in control of component mortar materials such as pigments or colored cements during manufacturing, evaluation of finished mortar color is best accomplished by observing certain general guidelines when viewing mock-ups, sample panels, or finished masonry construction.

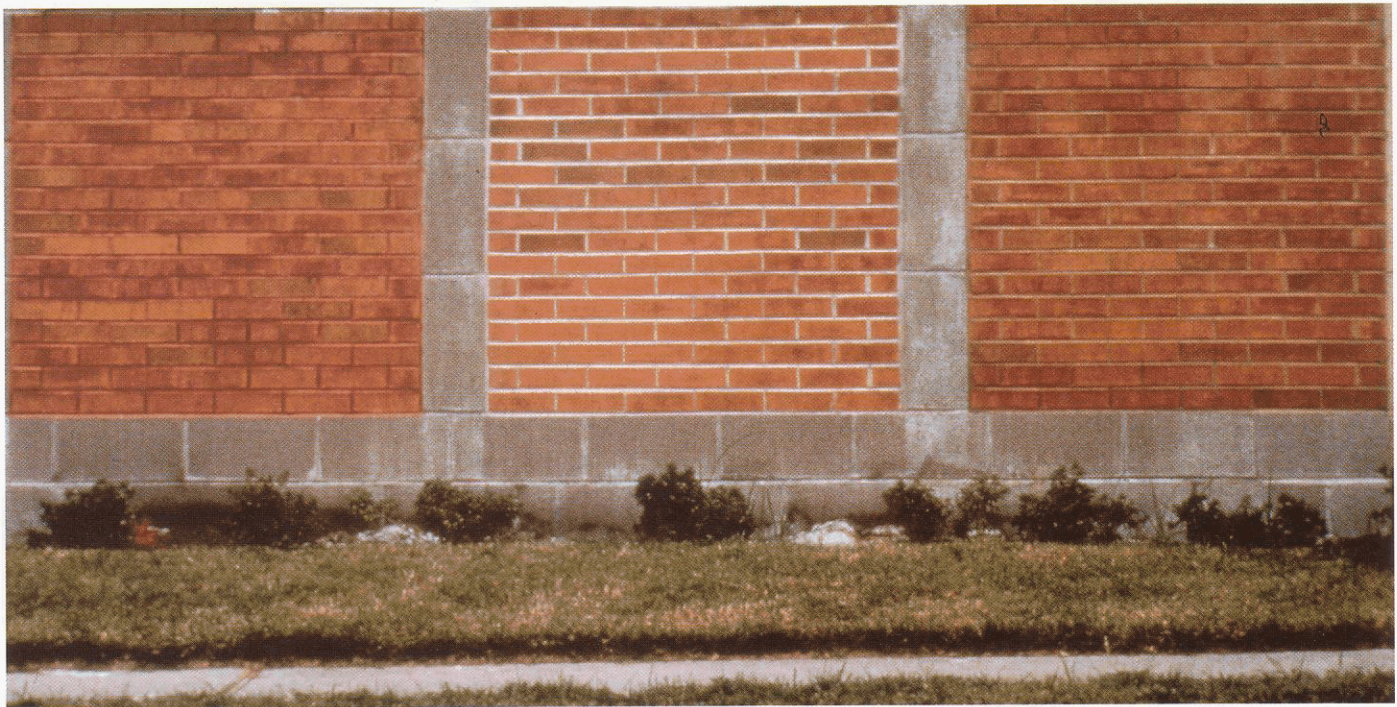

Fig. 2. These panels are constructed with the same brick and different colored mortars illustrating the effect mortar color can have on the overall appearance of masonry.

These guidelines are:

- Construct the panel in a safe area – retain for future reference if necessary.
- View the masonry together – this assures that purchaser (owner) and provider (mason) are examining the masonry under the same lighting and environment.
- Optimize viewing environment – view under strong but indirect sunlight if possible.
- Evaluate as a whole – consider the overall appearance of the masonry as basis for evaluation. Usually this entails observation from a distance of approximately 20-30 ft (6-9 m).
- Examine closely when questions arise – the cause for differences in appearance observed from a distance can often be determined by close inspection of the masonry.
- Discuss what you see – evaluation of appearance is subjective, but most people can agree on the general aspects of appearance.

Establishing Agreement

The masonry sample panel or mock-up is an important means of establishing agreement between purchaser and provider on what is expected and what is achievable. Depending on the complexity of the project, the role of a masonry sample panel or mock-up can go beyond providing a means for evaluating the appearance of masonry. However, establishing appearance criteria for the project is certainly one of the basic reasons for constructing, approving, and retaining sample panels or mock-ups.

In addition to following the general guidelines for evaluating the appearance of masonry previously mentioned, the mason contractor should be certain that the panel is indeed representative of what can be achieved on the project. The materials, batching and mixing procedures, level of workmanship, curing, and cleaning procedures used to construct the sample panel should be consistent with what will be provided in construction of the project. This requires planning on the part of both the owner and the mason contractor, to provide adequate time for the mortar to cure, for the panel to be cleaned, and for it to dry prior to evaluation of its appearance. Honest discussion between the owner or his representative and the mason contractor is required to assure that a clear understanding is reached on what appearance criteria are reasonable to expect in the completed masonry. For example, the mason may need to explain how the combination of the masonry unit's suction characteristics, sand quality, mortar type, and tooling requirements being used on a specific project affect consistency of texture and shade of mortar joints. The owner or the owner's representative may wish to emphasize concern that precautions such as covering units and walls are taken during construction to minimize variability in the appearance of mortar joints.

Understanding Mortar Color

The texture and color of a finished mortar joint are determined by properties of component mortar materials, preparation of the mortar, workmanship, curing conditions, cleaning procedures, and environmental factors. It is important that the mason understand these relationships in order to control the texture and color of mortar joints. It is important that the owner understand these relationships so the owner can better define expectations in achievable terms.

Materials. Conventional masonry mortar is made from sand, water, and masonry cement; sand, water, and mortar cement; or from sand, water, and a mixture of portland cement and hydrated lime. In order to achieve the desired mortar color, pigment may be added to the system, either as an ingredient of pre-pigmented cements or as an admixture. Each of the component materials influences the mortar appearance.

Sand primarily affects texture and shade of color. However, if a sand contains an appreciable percentage of clay or silt fines, it will also affect the hue and intensity of a mortar joint. The gradation of a sand will influence the water demand of the mortar and the texture of the mortar joint surface.

The color of the masonry cement, mortar cement, or the portland cement and lime used in a mortar mix influences the hue, shade, and intensity of a mortar joint. However, the dry powder appearance of these materials is not always indicative of their effect on mortar color. Cement and water (or cement, lime, and water) forms a paste that coats sand particles. The paste hardens as the cement reacts with the mixing water, and the hardened paste tends to dominate the color of the mortar. The color of the hardened paste is influenced by the inherent color of the cement (or combination of cement and lime) plus the ratio of water to cement in the paste. Mortars having higher water to cement ratios tend to be lighter in color than those having lower water contents.

Pigments are incorporated in a mortar to achieve a specific desired appearance. Having an extremely high fineness compared to other components of the mortar system, pigments become part of the cement paste and dominate the color of the paste and mortar. Since they have such a dramatic influence on mortar color, pigments are best incorporated into the mortar system as part of a pre-blended pigmented cement or in pre-weighed packages. Mineral oxide pigments (usually natural or synthetic iron oxides) are recommended for use in mortar, since they are compatible with cement and lime and provide color stability in the finished mortar joint. Carbon black pigments exhibit poor color stability in masonry mortar exposed to weather. Their use in exterior masonry should be avoided.

Proportioning and Mixing. Controlling mortar texture and color requires consistent materials and adequate procedures for assuring that these materials are properly proportioned and mixed. A change in the aggregate ratio of a mortar will result in a change in the amount of water required to achieve the desired workability, thus affecting both texture and color of the finished mortar joint. When cement and lime are used, changes in relative amounts of these components will also affect color and texture. As previously noted, mortar color is so sensitive to pigment content that proportioning is best accomplished by using pre-pigmented cements or pre-weighed pigment packages. Proper mixing is needed to assure uniformity within and between batches of mortar.

Unit Suction, Tooling, and Curing. When freshly mixed mortar is placed between absorptive masonry units, much of the water contained in the mortar is absorbed by the units. Thus the actual ratio of water to cement in a mortar joint when the mortar sets may be substantially lower than what the ratio was when the mortar was initially mixed. How



Fig. 3. In this example, a masonry prism was constructed using one batch of mortar. The top mortar joint was tooled immediately after placement of the unit. Remaining mortar joints were tooled at progressively greater time intervals and thus stiffer consistency. The relationship between mortar consistency when tooled and mortar color is quite apparent.

much lower will depend on the absorptive characteristics of the unit and the water retentive characteristics of the mortar.

The effect of tooling on the appearance of a mortar joint is dependent on the type of jointer used and the stiffness of the mortar at the time it is tooled. Tooling of mortar when it is highly plastic or flowable will tend to pull a high-water-content paste to the surface, resulting in a porous light-colored joint surface. If the mortar is allowed to become stiff before tooling, the joint surface will not readily yield to the pressure of the jointer, and friction developing between the metal jointer and the mortar joint will result in a dark streaked surface. When tooled at the proper consistency, the surface of the mortar joint is compacted, and a uniform appearance consistent with the body of the mortar is achieved. Since pigments, due to their high fineness, are easily concentrated on the surface of a mortar joint by tooling, the appearance of colored mortar joints is especially sensitive to the tooling technique used in finishing the mortar joint.

The cement paste hardens as it reacts with water. This process will continue over an extended time period, provided sufficient moisture is present and temperatures are well above freezing. Since the curing environment affects the micro-structure of the paste, slight permanent variations in shade may result from differences in curing conditions. However, when mortars are cured under different moisture conditions, the most dramatic differences in lightness and darkness are usually associated with variations in the free moisture content of the mortar. Mortars having high free moisture will appear darker than those having low moisture content. Such differences in appearance are temporary and will diminish as moisture levels reach an equilibrium.

Cleaning. Cleaning procedures often completely alter the appearance of a mortar joint, changing both texture and color. Most cleaning techniques are designed to remove mortar droppings or smears from the surface of newly constructed masonry. However, if these techniques dissolve the cement paste from the surface of a mortar joint, the appearance of that joint is no longer dominated by the color of the hardened cement paste, but reflects the appearance of sand particles that are exposed on the surface. The effect of improper cleaning is most dramatic on colored mortar joints, since the pigmented cement paste is relied upon in these systems to produce the desired color. In addition to altering the appearance of mortar joints, improper cleaning may damage masonry units and compromise the ability of the masonry to resist water penetration.

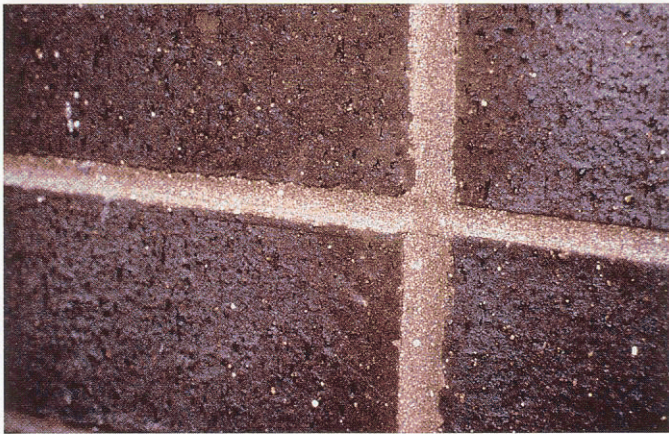

Fig. 4. The use of a strong acid cleaning solution has etched the surface of these mortar joints, exposed sand particles, and significantly changed the appearance of the mortar joint.

Controlling the Appearance of Mortar Joints

Understanding what factors affect the appearance of mortar joints provides a basis for establishing control of the texture and color of mortar joints. Masonry walls and mortar joints will not exhibit the uniformity of appearance characteristic of flat painted surfaces. Indeed, since part of the attractiveness of masonry is rooted in its earthy appearance and hand-assembled heritage, paint-like uniformity is not generally desirable. However, aside from minor fluctuations in shade and texture that tend to impart depth and

character to the masonry, the mason contractor and his crew can control the appearance of mortar joints by controlling key variables as follows:

Use the Same Mortar Materials. Changes in brands of masonry cement, mortar cement, portland cement, hydrated lime, or pigments during construction of a project should be avoided. All of the sand should be from the same source. When multiple sand shipments are required, the mason contractor should visually check the appearance of successive shipments to assure that sand color and gradation has not changed significantly. For jobs having particularly demanding requirements on mortar color, it may be advisable to keep a small quantity of sand from the first shipment in a sealed container for comparison with subsequent shipments.



Fig. 5. The difference in mortar color in this example was determined to be the result of a change in both sand and type of cement used in the mortar.

Control Proportioning and Mixing of Mortar. Masonry cement, mortar cement, portland cement, and hydrated lime are typically delivered in pre-weighed packages. Thus, consistent proportioning of these ingredients is assured by adding these ingredients to the mixer in bag increments or sometimes in increments of a simple fraction of a bag. For example, a Type S mortar can be made adding one bag of Type S masonry cement and 3 parts by volume of damp loose sand to the mortar mixer or by adding one bag of Type N masonry cement, half a bag of portland cement, and 4 1/2 parts by volume of damp loose sand to the mortar mixer.

Some positive control should be established to assure that the proper amount of sand is used. This can be accomplished by periodically checking the required shovel count with a cubic foot (0.28 m³) box, by using a cubic foot measuring box to add the sand to the mixer, or by using other containers of known volume to measure the sand. Since the bulk volume of sand is influenced by its moisture content, sand should be maintained in a damp loose condition to assure uniform proportioning (see *Trowel Tips: Mortar Sand*, IS242).

Adequate mixing is required to assure uniformity within and between batches of mortars. Mechanical mixing of

mortar is recommended. The mixer should be conveniently located next to the sand pile and water. Conventional mortar mixers are of rotating-spiral or paddle-blade design with tilting drum. *After all batched materials are together, they should be mixed for 3 to 5 minutes.* For pigmented mortars, mixing the full five minutes is advisable. Batching procedures will vary with individual preferences. Experience has shown that good results can be obtained when about three-fourths of the required water, one-half of the sand, and all the cementitious materials are briefly mixed together. The balance of the sand is then charged and the remaining water added to bring the mortar to optimum working consistency. The amount of water added should be the maximum that is consistent with satisfactory workability. Evaluation of optimum consistency by the mason requires an understanding of how absorption characteristics of the masonry units and ambient weather conditions affect masonry construction.

Schedule the mortar production to keep pace with the progress of construction. Mortar that has been mixed but not used immediately tends to dry out and stiffen. Loss of water by absorption and evaporation on a dry day can be reduced by wetting the mortar board and covering the mortar in the mortar box, wheelbarrow, or tub. Avoid producing mortar too far ahead of expected use to minimize retempering requirements. Retemper colored mortar cautiously to avoid color changes. Water content and stiffness of mortar during tooling affect color (see section on unit suction, tooling, and curing).

Control Unit Moisture Content. Variable IRA within a given brick blend can make tooling difficult and affect color. While the Initial Rate of Absorption (IRA) is an inherent property of the units and is probably beyond the control of the mason contractor, covering brick and block stored at the project site will eliminate variations in mortar appearance resulting from the use of wet and dry units. If it is necessary to wet high IRA clay units, the contractor should make certain that all units used are subjected to the same procedure. PCA's *Trowel Tips: Hot-Weather Masonry Construction*, IS243, outlines some procedures that can be used to accomplish uniform wetting of clay units. Concrete masonry units should never be wet when placed in the wall.

Use Proper Tooling Techniques. Different joint finishes are often selected to provide a desired appearance in the completed masonry. The mason must have the appropriate equipment to provide the desired finish and know how to use it to achieve a consistent appearance. In general, he should allow mortar joints to stiffen before tooling until the surface is hard enough that a thumbprint just barely shows. Special care must be taken with white or very light-colored mortars to assure that joint surfaces are not discolored with metallic deposits from the jointer. Use ceramic, stainless steel, or plastic jointers when working with such mortars.

Minimize Cleaning Requirements. When it comes to cleaning masonry, less is better. Careful workmanship includes implementing skills that minimize mortar droppings and smears on the face of the masonry. The mason contractor can use straw, sand, or plastic to protect the base of the wall from rain-splashed mud and mortar splatter, and he can assure that the inside scaffold board is

turned on edge at the end of each working day to prevent rain from splashing mortar and dirt onto the masonry wall. Covering the tops of walls at the end of each working day will prevent rain from entering walls and help reduce the possibility of efflorescence.

Clean Masonry Carefully. Use the least aggressive cleaning technique possible. Make certain that the cleaning procedure is consistent with the recommendations of the manufacturer of the units, and pre-qualify the procedure on the sample panel and a small test area of the building. When acid based cleaning solutions are used, the mortar should be allowed to cure at moderate temperatures for about seven days prior to cleaning. After cleaning a trial area, allow the area to dry, and closely examine mortar joint surfaces to ascertain that the procedure has not etched the surface. A more detailed discussion about this topic is contained in PCA's *Trowel Tips: Cleaning Masonry*, IS244. **View with Pride.** It was noted at the beginning of this document that an appreciation for the inherent beauty of masonry is often the reason it is selected by the owner as a building component. Hopefully, that appreciation of masonry is shared by the mason contractor and his crew and will motivate each person to do his part to assure that the finished project is one in which all can take pride.



Fig. 6. With care and cooperation, consistent mortar color producing the appearance desired by the owner can be achieved.

Related Publications

Readers of this publication may also be interested in the following publications available for purchase from the Portland Cement Association. A complete listing of PCA publications is given in the free **PCA Catalog** (MS254G). To order, write or call Order Processing, Portland Cement Association, 5420 Old Orchard Road, Skokie, Illinois 60077-1083, phone 847/966-6200.

Concrete Masonry Handbook, EB008M

Mortars for Masonry Walls, IS040M

Masonry Cement Mortars, IS181M

Trowel Tips: Efflorescence, IS239M

Trowel Tips: Tuckpointing, IS240M

Trowel Tips: Mortar Sand, IS241M

Trowel Tips: Field Testing Mortar, IS242M

Trowel Tips: Hot-Weather Masonry Construction,
IS243M

Trowel Tips: Cleaning Masonry, IS244M

*Trowel Tips: Workmanship Part I, Preparing for
Quality*, IS245M

*Trowel Tips: Workmanship Part II, Imparting Quality to
Masonry*, IS246M

Recommended Practices for Laying Concrete Block,
PA043M

*Recommended Practices & Guide Specifications for
Cold Weather Masonry Construction*, LT107M

CAUTION: Contact with wet (unhardened) concrete, mortar, cement, or cement mixtures can cause SKIN IRRITATION, SEVERE CHEMICAL BURNS, or SERIOUS EYE DAMAGE. Wear waterproof gloves, a long-sleeved shirt, full-length trousers, and proper eye protection when working with these materials. If you have to stand in wet concrete, use waterproof boots that are high enough to keep concrete from flowing into them. Wash wet concrete, mortar, cement, or cement mixtures from your skin immediately after contact. Indirect contact through clothing can be as serious as direct contact, so promptly rinse out wet concrete, mortar, cement, or cement mixtures from clothing. Seek immediate medical attention if you have persistent or severe discomfort.

This publication is intended SOLELY for use by PROFESSIONAL PERSONNEL who are competent to evaluate the significance and limitations of the information provided herein, and who will accept total responsibility for the application of this information. The Portland Cement Association DISCLAIMS any and all RESPONSIBILITY and LIABILITY for the accuracy of and the application of the information contained in this publication to the full extent permitted by law.

Portland Cement Association 5420 Old Orchard Road, Skokie, Illinois 60077-1083



An organization of cement manufacturers to improve and extend the uses of portland cement and concrete through market development, engineering, research, education, and public affairs work.

TEK 03-01C

ALL-WEATHER CONCRETE MASONRY CONSTRUCTION

INTRODUCTION

Masonry construction can continue during hot, cold, and wet weather conditions. The ability to continue masonry construction in adverse weather conditions requires consideration of how environmental conditions may affect the quality of the finished masonry. In some cases, environmental conditions may warrant the use of special construction procedures to ensure that the masonry work is not adversely affected. One of the prerequisites of successful all-weather construction is advance knowledge of local conditions. Work stoppage may be justified if a short period of very cold or very hot weather is anticipated. The best source for this type of information is the U.S. Weather Bureau, Environmental Science Services Administration (ESSA) of the U.S. Department of Commerce which can be [accessed at their web site](http://www.ncdc.noaa.gov) (<http://www.ncdc.noaa.gov>).

In the following discussion, ambient temperature refers to the surrounding jobsite temperature when the preparation activities and construction are in progress. Similarly the mean daily temperature is the average of the hourly temperatures forecast by the local weather bureau over a 24 hour period following the onset of construction. Minimum daily temperature is the lowest temperature expected during the period. Temperatures between 40° and 90°F (4.4° and 32.2°C) are considered “normal” temperatures for masonry construction and therefore do not require special procedures or protection protocols.

COLD WEATHER CONSTRUCTION

When ambient temperatures fall below 40°F (4.4°C), the Specification for Masonry Structures (ref. 3) requires consideration of special construction procedures to help ensure the final construction is not adversely affected. Similarly when the minimum daily temperature for grouted masonry or the mean temperature for ungrouted masonry falls below 40°F (4.4°C) during the first 48 or 24 hours after construction respectively, special protection considerations are required.

Mortar and Grout Performance

Hydration and strength development in mortar and grout generally occurs at temperatures above 40°F (4.4°C) and only when sufficient water is available. However, masonry construction may proceed when temperatures are below 40°F (4.4°C) provided cold weather construction and protection requirements of reference 3 are followed.

Mortars and grouts mixed at low temperatures have longer setting and hardening times, and lower early strength than those mixed at normal temperatures. However, mortars and grouts produced with heated materials exhibit performance characteristics identical to those produced during warm weather.

Effects of Freezing

The initial water content of mortar can be a significant contributing factor to the resulting properties and performance of mortar, affecting workability, bond, compressive strength, and susceptibility to freezing. Research has shown a resulting disruptive expansion effect on the cement-aggregate matrix when fresh mortars with water contents in excess of 8 %mortar are frozen (ref. 2). This disruptive effect increases as the water content increases. Therefore, mortar should not be allowed to freeze until the mortar water content is reduced from the initial 11% to 16% range to a value below 6%. Dry concrete masonry units have a demonstrated capacity to achieve this moisture reduction in a relatively short time. It is for this reason that the specification requires protection from freezing of mortar for only the first 24 hours (ref. 3).

Grout is a close relative of mortar in composition and performance characteristics. During cold weather, however, more attention must be directed toward the protection of grout because of the higher water content and resulting disruptive expansion that can occur from freezing of that water. Therefore, grouted masonry needs to be protected for longer periods to allow the water content to be dissipated.

Cement

During cold weather masonry construction, Type III, high- early strength portland cement should be considered in lieu of Type I portland cement in mortar or grout to accelerate setting. The acceleration not only reduces the curing time but generates more heat which is beneficial in cold weather.

Admixtures

The purpose of an accelerating type of admixture is to hasten the hydration of the portland cement in mortar or grout. However, admixtures containing chlorides in excess of 0.2% chloride ions are not permitted to be used in mortar (ref. 3) due to corrosion of embedded metals and contribution to efflorescence. While specifically not addressed by the Specification, the use of chloride admixtures in grout is generally discouraged.

Nonchloride accelerators are available but they must be used in addition to cold weather procedures and not as a replacement for them. Antifreezes are not recommended for use in mortars and are prohibited for use in grouts.

Material Storage

Construction materials should be protected from water by covering. Bagged materials and masonry units should be protected from precipitation and ground water by storage on pallets or other acceptable means.

Coverings for materials include tarpaulins, reinforced paper, polyethylene, or other water repellent sheet materials. If the weather and size of the project warrant, a shelter may be provided for the material storage and mortar mixing areas.

Material Heating

When the ambient temperature falls below 40°F (4.4°C) during construction, or mean daily temperature is predicted to fall below 40°F (4.4°C) during the first 24 hours following construction of ungrouted masonry, or the minimum daily temperature is predicted to fall below 40°F (4.4°C) during the first 48 hours for grouted masonry, Specification for Masonry Structures (ref. 3) requires specific construction and protection procedures to be implemented as summarized in Tables 1a and 1b. As indicated in Table 1a, the temperature of dry masonry units may be as low as 20°F (-6.7°C) at the time of placement. However, wet frozen masonry units should be thawed before placement in the masonry. Also, even when the temperature of dry units approaches the 20°F (-6.7°C) threshold, it may be advantageous to heat the units for greater mason productivity.

Masonry should never be placed on a snow or ice-covered surface. Movement occurring when the base thaws will cause cracks in the masonry. Furthermore, the bond between the mortar and the supporting surface will be compromised.

Glass Unit Masonry

For glass unit masonry, both the ambient temperature and the unit temperature must be above 40°F (4.4°C) and maintained above that temperature for the first 48 hours (ref. 3).

Table 1a—Cold Weather Masonry Construction Requirements (ref. 3)	
Ambient temperature	Construction requirements
32 to 40°F (0 to 4.4°C)	Do not lay masonry units having a temperature below 20°F (-6.7°C). Remove visible snow and ice on masonry units before the unit is laid in the masonry. Remove snow and ice from foundation. Heat existing foundation and masonry surfaces to receive new masonry above freezing. Heat mixing water or sand to produce mortar temperatures between 40 and 120°F (4.4 and 48.9°C). Grout materials to be 32°F (0°C) minimum. Do not heat water or aggregates above 140°F (60°C).
25 to 32°F (-3.9 to 0°C)	Same as above for mortar. Maintain mortar temperature above freezing until used in masonry. Heat grout aggregates and mixing water to produce grout temperatures between 70 and 120°F (21.1 and 48.9°C). Maintain grout temperature above 70°F (21.1°C) at time of grout placement.
20 to 25°F (-6.7 to -3.9°C)	Same as above, plus use heat masonry surfaces under construction to 40°F (4.4°C) and install wind breaks or enclosures when wind velocity exceeds 15 mph (24 km/hr). Heat masonry to a minimum of 40°F (4.4°C) prior to grouting.
20°F (-6.7°C) and below	Same as above, plus provide an enclosure for the masonry under construction and use heat sources to maintain temperatures above 32°F (0°C) within the enclosure.

Table 1a—Cold Weather Masonry Construction Requirements (ref. 3)

Table 1b—Cold Weather Masonry Protection Requirements (ref. 3)	
Mean daily temperature for ungrouted masonry Minimum daily temperature for grouted masonry	Protection requirements
25 to 40°F (-3.9 to 4.4°C)	Protect completed masonry from rain or snow by covering with a weather-resistive membrane for 24 hours after construction.
20 to 25°F (-6.7 to -3.9°C)	Completely cover the completed masonry with a weather-resistive insulating blanket or equal for 24 hours after construction (48 hr for grouted masonry unless only Type III portland cement used in grout).
20°F (-6.7°C) and below	Maintain masonry temperature above 32°F (0°C) for 24 hours after construction by enclosure with supplementary heat, by electric heating blankets, by infrared heat lamps, or by other acceptable methods. Extend time to 48 hours for grouted masonry unless the only cement in the grout is Type III portland cement.

Table 1b—Cold Weather Masonry Protection Requirements (ref. 3)

HOT WEATHER CONSTRUCTION

High temperatures, solar radiation, and ambient relative humidity influence the absorption characteristics of the masonry units and the setting time and drying rate for mortar. When mortar gets too hot, it may lose water so rapidly that the cement does not fully hydrate. Early surface drying of the mortar results in decreased bond strength and less durable mortar. Hot weather construction procedures involve keeping masonry materials as cool as possible and preventing excessive water loss from the mortar. Specific hot weather requirements of the Specification for Masonry Structures (ref. 3) are shown in Tables 2a and 2b.

Additional Recommendations

Store masonry materials in a shaded area. Use a water barrel as water hoses exposed to direct sunlight can result in water with highly elevated temperatures. The barrel may be filled with water from a hose, but the hot water resulting from hose inactivity should be flushed and discarded first. Additionally, mortar mixing times should be no longer than 3 to 5 minutes and smaller batches will help minimize drying time on the mortar boards.

To minimize mortar surface drying, past requirements contained within Specification for Masonry Structures (ref. 3) were to not spread mortar bed joints more than 4 feet (1.2 m) ahead of masonry and to set masonry units within one minute of spreading mortar. This is no longer a requirement in the current document but the concept still merits consideration. If surface drying does occur, the mortar can often be revitalized by wetting the wall but care should be taken to avoid washout of fresh mortar joints.

Ambient temperature	Preparation and construction requirements
Above 100°F (37.8°C) or above 90°F (32.2°C) with a wind speed greater than 8 mph (12.9 km/hr)	Maintain sand piles in a damp, loose condition. Maintain temperature of mortar and grout below 120°F (48.9°C). Flush mixer, mortar transport container, and mortar boards with cool water before they come into contact with mortar ingredients or mortar. Maintain mortar consistency by retempering with cool water. Use mortar within 2 hours of initial mixing.
Above 115°F (46.1°C) or above 105°F (40.6°C) with a wind speed greater than 8 mph (12.9 km/hr)	Same as above, plus materials and mixing equipment are to be shaded from direct sunlight. Use cool mixing water for mortar and grout. Ice is permitted in the mixing water as long as it is melted when added to the other mortar or grout materials.

☒ Table 2a—Hot Weather Masonry Preparation and Construction Requirements (ref. 3)

Mean daily temperature	Protection requirements
Above 100°F (37.8°C) or above 90°F (32.2°C) with a wind speed greater than 8 mph (12.9 km/hr)	Fog spray all newly constructed masonry until damp, at least three times a day until the masonry is three days old.

☒ Table 2b—Hot Weather Masonry Protection Requirements (ref. 3)

WET WEATHER CONSTRUCTION

Even when ambient temperatures are between 40 and 90°F (4.4 and 32.2°C), the presence of rain, or the likelihood of rain, should receive special consideration during masonry construction. Unless protected, masonry construction should not continue during heavy rains, as partially set or plastic mortar is susceptible to washout, which could result in reduced strength or staining of the wall. However, after approximately 8 to 24 hours of curing (depending upon environmental conditions), mortar washout is no longer of concern. Further, the wetting of masonry by rainwater provides beneficial curing conditions for the mortar (ref. 2).

When rain is likely, all construction materials should be covered. Newly constructed masonry should be protected from rain by draping a weather-resistant covering over the assemblage. The cover should extend over all mortar that is susceptible to washout.

Recommended Maximum Unit Moisture Content

When the moisture content of a concrete masonry unit is elevated to excessive levels due to wetting by rain or other sources, several deleterious consequences can result including increased shrinkage potential and possible cracking, decreased mason productivity, and decreased mortar/unit bond strength. While reinforced masonry construction does not rely on mortar/unit bond for structural capacity, this is a design consideration with unreinforced masonry. As such, the concerns associated with structural bond in reinforced masonry construction are diminished.

As a means of determining if a unit has acceptable moisture content at the time of installation, the following industry recommended guidance should be used. This simple field procedure can quickly ascertain whether a concrete masonry unit has acceptable moisture content at the time of installation.

A concrete masonry unit for which 50% or more of the surface area is observed to be wet is considered to have unacceptable moisture content for placement. If less than 50% of the surface area is wet, the unit is acceptable for placement. Damp surfaces are not considered wet surfaces.

For this application, a surface would be considered damp if some moisture is observed, but the surface darkens when additional free water is applied. Conversely, a surface would be considered wet if moisture is observed and the surface does not darken when free water is applied.

It should be noted that these limitations on maximum permissible moisture content are not intended to apply to intermittent masonry units that are wet cut as needed for special fit.

In addition to the effects of wind on hot and cold weather construction, the danger of

WINDY WEATHER CONSTRUCTION

excessive wind resulting in structural failure of newly constructed masonry prior to the development of strength or before the installation of supports must be considered. **TEK 3-4C** Bracing Concrete Masonry Walls During Construction (ref. 1) provides guidance in this regard.

References

1. Bracing Concrete Masonry Walls During Construction, **TEK 3-4C**. National Concrete Masonry Association, 2014
2. Hot & Cold Weather Masonry Construction. Masonry Industry Council, 1999.
3. Specification for Masonry Structures, ACI 530.1-02/ASCE 6-02/TMS 602-02. Reported by the Masonry Standards Joint Committee, 2002.

NCMA TEK 03-01C, Revised 2002.

NCMA and the companies disseminating this technical information disclaim any and all responsibility and liability for the accuracy and the application of the information contained in this publication.

Keywords

cold weather construction

construction techniques

grout

hot weather construction

mortar

rain

snow

storage of materials

wet weather construction

windy weather construction

Best Practices for Successfully Cleaning Architectural Concrete Masonry Walls



Cleaning concrete masonry walls is a key step to achieving a beautiful end result. Care must be taken however to assure that the cleaning method itself does not damage the wall.

More than any other task performed by a mason contractor, cleaning is a “means and methods” function. Building codes and contract documents spell out performance requirements, however in most instances it should be left to the mason contractor to determine the process to follow to achieve the requirements.

Masonry producers, chemical manufacturers and equipment companies can all provide valuable suggestions. However, there are many variables and only the mason is in a position to evaluate conditions and make adjustments. **Only one step should never be varied: test your means and methods before you start.** The consequences of not testing first can cost a mason contractor a tremendous amount of money if the wall is damaged.

Listed below are some considerations to combine with your experience that we hope will help you successfully clean concrete masonry walls.

QUICK POINTS

- Clean off droppings and stains as the wall is built to minimize post-construction cleaning.
- Protect masonry materials from water intrusion and mud stains during construction.
- Clean the walls promptly for easiest and best results.
- Use the gentlest available cleaning method.
- Always demonstrate and gain acceptance for cleaning methods on the sample panel first.
- If cleaning is done later than ideally it should be, test first and explore alternatives to aggressive cleaning with acid based cleaners.

Code Requirements

When we reference Code in this document, we are referring to **TMS 402/602 "Building Code Requirements and Specifications for Masonry Structures."** It is very telling that the Specification Language in TMS 602 does not suggest the use of any particular cleaning method, but instead is direct and results-based:

Clean the exposed masonry surfaces of stains, efflorescence, mortar, grout dropping and debris using methods that do not damage the masonry.

Specifiers should follow this example, because experience teaches us that strictly defining a cleaning method in the specification typically will not be able to address the multitude of variables that occur in the field (e.g., the type of architectural concrete masonry, the condition of the masonry walls, timing of the cleaning, weather conditions, etc.)

The sample panel, which serves as the basis for acceptance of the masonry work, is the best place to test the cleaning means and methods prior to using them on the masonry walls. A sample panel is required by Code, and as the commentary to TMS 602 states:

Sample panels should contain the full range of unit and mortar color. Each procedure, including cleaning and application of coatings and sealants, should be demonstrated on the sample panel. The effect of these materials and procedures on the masonry can then be determined before large areas are treated. . .

The Jobsite Sample Panel

The question of whether a wall has been adequately cleaned can become tricky if there is no agreed standard of reference for what that means. This is where the sample panel comes into play. TMS 602 "Specifications for Masonry Structures" states: "The acceptable standard for the work is established by the accepted panel."

One of the functions of a sample panel is setting the standard for the aesthetics for the finished walls. The sample panel establishes the acceptable standard of quality for the project and defines what clean means. Therefore if the walls of the project will have insignificant stains when you are done, the sample panel should reflect the finished wall and also have insignificant stains. This can be addressed with the project team during a pre-construction meeting before the sample panel is built. A key goal of the pre-construction meeting where the sample panel is accepted is to establish a standard for acceptance of cleaning results.



Why is it so important to test first?

Unfortunately, even successful results on past projects using a specific cleaning product and method do not mean that success can be repeated unless the variables influencing cleaning are the exactly the same. Many variables influence whether a particular method will work on a given project. Concrete masonry units and mortar joints react differently to various cleaning methods. Weather conditions, including hot or cold weather, humidity and wind can all influence cleaning results. The texture, color, shape and surface strength of the masonry you are attempting to clean all contribute to the sensitivity of the surface to damage from the cleaning process.

The cost of testing the cleaning means and methods first is a fraction of the time and money it will take to wash the walls a second time if the first attempt wasn't successful. Or worse, your cleaning method was too aggressive and the wall was damaged. There are too many variables to take this risk and not test first. If you want to test your methods early, most masonry manufacturers will provide units free for you to test your cleaning process even before the sample panel is built. Starting early facilitates evaluating a variety of products for both labor and cleaning efficiency.

Even after the sample panel results have been accepted it is wise to consider whether the actual walls are in similar condition. Sample panels are typically cleaned before the stains have fully cured or hardened. If the stains on the actual walls have cured a longer period than those demonstrated on the sample panel, a new test section on the wall should be demonstrated and approved before attempting to clean the entire wall.

Minimizing the Risk of Cleaning Damage

Experience teaches that there are some approaches and situations that are more likely to result in cleaning related damage:

Use of Unregulated High Pressure Water:

Use of high pressure water from pressure washers in an unregulated fashion can result in uneven results, excess water penetration (and resulting efflorescence formation), "wand" marks, and loss of cement paste from the masonry and mortar. Particularly where the wall is already covered with an acid based cleaning solution, pressure should be kept as low as practical, and care should be taken especially not to scour the wall or blast it from close range with high pressure.



Cleaning Wall Sections that are too large:

Limiting the size of the area that is cleaned as a section will result in more even results and better control over dwell times and rinse off. In the picture at left, the area is kept narrow enough that control can be maintained.

Not having adequate control over timing of cleaner application (dwell times):

A set amount of time should be tracked for each stage in the cleaning process, and particularly for the amount of time the cleaner dwells on the surface of the wall. Keep tabs on timing when the method is tested and follow that timing throughout the work. Use a timer to assure repeatable results.



Basing evaluations on walls that are still

wet: To be able to properly evaluate cleaning results, the walls must be allowed to dry adequately.



Cleaning walls during adverse weather conditions: Cleaning products will act differently in hot or cold conditions and drying times are influenced by wind conditions. Application of an acid based cleaner on a hot windy day requires reducing the area cleaned per section to allow proper removal of the cleaner. This can be a cause of staining if not addressed.

Waiting too long to clean: The longer mortar stains are allowed to stay on the concrete masonry, the more bonded they become, and the risk of damage increases as more aggressive means are needed to remove them.

Unprotected Walls (excessive efflorescence

formation): One of the primary causes of excessive staining is allowing the masonry walls to be soaked by rain during or after masonry construction. Avoiding this problem by taking steps to protect the walls by covering the top simplifies the task of cleaning and reduces the need for aggressive cleaning methods.

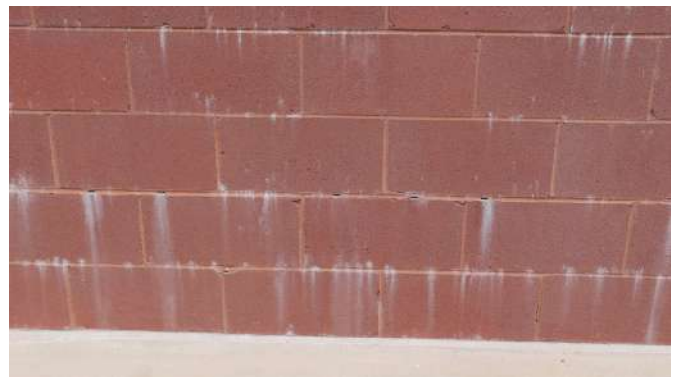

How to Handle Difficult Cleaning Situations

Following the standard sample panel process and cleaning the walls promptly after construction is the best way to assure good results. But what if something goes wrong on the job? For example, what if mortar or grout stains are allowed to fully harden on the wall contrary to specified cleaning requirements? When significant mortar, grout and stains are left on the wall, and allowed to fully harden before cleaning, the mason must often resort to aggressive chemicals to clean the wall. This can lead to problems.

Unless applied by experts, aggressive chemical cleaners can damage and change the appearance of the wall. Aggressive application of cleaners can etch and scar, or change the color or texture of architectural masonry. Acid-based cleaners may actually remove significant amounts of cement paste from the concrete – which may have detrimental effects on both appearance and long-term moisture protection of the wall system.

BEFORE this happens, investigate the use of alternate cleaning materials and methods including baking soda blasting. Such methods can remove difficult mortar and grout stains without damaging the wall.

Conclusion

The cleaning method always should be tested on the sample panel, or if that is not possible on an inconspicuous portion of the wall to avoid damaging the aesthetics of the main wall sections – The last thing you want to do is expose the entire wall to a cleaning method before knowing that it is not damaging.



Questions?

For more information, visit concreteproductsgroup.com or email your questions to info@concreteproductsgroup.com



Sure Klean®

CLEANING & PROTECTIVE TREATMENTS

Light Duty Concrete Cleaner

Sure Klean® Light Duty Concrete Cleaner is specially formulated to remove common construction and atmospheric staining from a variety of substrates, including smooth architectural and engineered concrete, custom masonry, concrete brick, manufactured stone and decorative pavers.

This general-purpose, non etching acidic cleaner removes rust, mud, atmospheric dirt, mortar smears and other stains without altering the surface texture. Light Duty Concrete Cleaner adds depth to colors, brightens white matrices and exposed aggregate.

ADVANTAGES

- Effective on multiple substrates, including manufactured stone and concrete brick.
- Improves color uniformity and enhances appearance.
- Contains no muriatic acid.
- Removes common construction stains and atmospheric dirt.
- Removes efflorescence stains on brick and decorative pavers, new concrete and stone construction, as well as secondary efflorescence on concrete block.
- Removes localized rust and other metallic staining on unpolished limestone, travertine and marble. Always test.
- Safe for most pigmented concrete and colored mortar.
- Water rinsable.

Limitations

- Acidic contents may damage polished masonry, some non masonry and acid-sensitive surfaces.
- May remove some surface-applied accent colors. Always test to confirm suitability and results before overall application.
- Not for use on treated low-E glass; acrylic and polycarbonate sheet glazing; and glazing with surface-applied reflective, metallic or other synthetic coatings and films.

REGULATORY COMPLIANCE

VOC Compliance

Sure Klean® Light Duty Concrete Cleaner is compliant with all national, state and district VOC regulations.

TYPICAL TECHNICAL DATA

FORM	Clear, colorless liquid Slight odor
SPECIFIC GRAVITY	1.129
pH	0.976 @ 1:2 dilution 1.33 @ 1:3 dilution 1.82 @ 1:6 dilution
WT/GAL	9.39 lbs
ACTIVE CONTENT	not applicable
TOTAL SOLIDS	not applicable
VOC CONTENT	not applicable
FLASH POINT	not applicable
FREEZE POINT	12° F (-11° C)
SHELF LIFE	3 years in tightly sealed, unopened container

SAFETY INFORMATION

Always read full label and SDS for precautionary instructions before use. Use appropriate safety equipment and job site controls during application and handling.

24-Hour Emergency Information:
INFOTRAC at 800-535-5053

Product Data Sheet

Sure Klean® Light Duty Concrete Cleaner

PREPARATION

Protect people, vehicles, property, metal, painted surfaces, plants and other non masonry materials from product, residue, rinse, splash, wind drift and fumes. When working over traffic, clean when traffic is at a minimum. Protect or divert traffic if necessary.

When applying to the exteriors of occupied buildings, make sure all windows, exterior intakes and air conditioning vents are covered and air handling equipment are shut down during application.

Clean masonry before installing windows, doors, finished flooring, metal fixtures, hardware, light fixtures, roofing materials and other non masonry items. If already installed, protect with polyethylene before application. Sure Klean® Strippable Masking is appropriate for use with this product to protect windows.

All caulking and sealant materials should be in place and thoroughly cured before cleaning.

Protect wall cavities during construction to prevent rainwater saturation and related staining. Let newly constructed surfaces dry and cure thoroughly before cleaning. Excessive moisture may mobilize staining and cause unsatisfactory cleaning results.

Cleaning high-strength mortar/grout on all substrates within seven days improves results.

Concrete Brick & Manufactured Stone Surfaces

Remove mortar residues and construction soiling from concrete brick and manufactured stone surfaces within 7–14 days of tooling the mortar joints. Let mortar/grout cure at least 7 days before cleaning.

The accent color found on many types of manufactured stone is sensitive to any cleaning operation. To limit the potential for loss of accent color, minimize the accumulation of excess mortar on the face of the manufactured stone. Avoid bonding agents whenever practical as they make excess mortar more difficult to remove without loss of applied accent colors. Clean carefully as you go, using fresh water and a soft brush.

New Brick & Tile Surfaces

Construction soiling and mortar residues on new brick and tile surfaces clean most effectively if the cleaning is done within 14–28 days of installation. Mortar and grout smears left on the surface longer result in a more difficult clean down and may cause undesirable results.

Surface and Air Temperatures

For best results, clean when air and masonry surface temperatures are 40° F (4° C) or above. Do not apply when temperature is below freezing or will be overnight. If freezing conditions exist before application, let the surface thaw.

Equipment

Apply with a soft-fiber, tampico masonry washing brush or with low-pressure (50 psi max) spray equipment fitted with acid-resistant hoses and gaskets. Do not use pressure spray above 50 psi. This drives the cleaner into the surface, making rinse difficult and may cause stains. Do not atomize.

Rinse with enough water and pressure to flush spent cleaner and dissolved soiling from the masonry surface and surface pores without damage. Inadequate rinsing leaves residues which may stain the cleaned surface.

Recommended for these substrates. Always test. Coverage is in sq.ft./m. per gallon of concentrate.

Substrate	Type	Use?	Coverage
Architectural Concrete Block	Burnished	yes	300–400 sq.ft. 28–37 sq.m.
	Smooth	yes	
	Split-faced	yes	
	Ribbed	yes	
Concrete	Brick	yes	300–600 sq.ft. 28–56 sq.m.
	Tile	yes	
	Precast Panels	yes	
	Pavers	yes	
	Cast-in-place	yes	
Fired Clay	Brick♦	yes	300–400 sq.ft. 28–37 sq.m.
	Tile	no	
	Terra Cotta (unglazed)	no	
	Pavers♦	yes	
Marble, Travertine, Limestone	Polished	no	N/A
	Unpolished*	yes	300–600 sq.ft. 28–56 sq.m.
Granite	Polished	yes	300–500 sq.ft. 28–46 sq.m.
	Unpolished	yes	
Sandstone	Unpolished	yes	300–400 sq.ft. 28–37 sq.m.
Slate	Unpolished	yes	300–500 sq.ft. 28–46 sq.m.

♦Sure Klean® 600, 101 Lime Solvent or Vana Trol® may be more suitable.

*For use in removing localized rust and other metallic staining. ALWAYS TEST for suitable results before overall use, especially on marble surfaces.

Always test to ensure desired results. Coverage estimates depend on surface texture and porosity.

Product Data Sheet

Sure Klean® Light Duty Concrete Cleaner

Masonry-washing equipment generating 400–1000 psi with a water flow rate of 6–8 gallons per minute is the best water/pressure combination for rinsing porous masonry. Use a 15–45° fan spray tip. Heated water (150–180° F; 65–82° C) may improve cleaning efficiency. Use adjustable equipment for reducing water flow-rates and rinsing pressure as needed for sensitive surfaces.

NOTE: When cleaning sensitive surfaces such as manufactured stone, if testing shows pressure rinsing can be safely used, 400 psi is sufficient to rinse dissolved soiling and spent cleaner from the surface. Higher psi risks wand marks, eroded mortar joints and loss of surface color and texture.

Rinsing pressures greater than 1000 psi and fan spray tips smaller than 15° may permanently damage sensitive masonry. Water flow-rates less than 6 gallons per minute may reduce cleaning productivity and contribute to uneven cleaning results.

Storage and Handling

Store in a cool, dry place with adequate ventilation. Always seal container after dispensing. Do not alter or mix with other chemicals. Published shelf life assumes upright storage of factory-sealed containers in a dry place. Maintain temperature of 45–100° F (7–38° C). Do not double stack pallets. Dispose of unused product and container in accordance with local, state and federal regulations.

APPLICATION

Read “Preparation” and the Safety Data Sheet before use. **ALWAYS TEST** a small area (minimum 4-ft x 4-ft) of each surface to confirm suitability and desired results before beginning overall application. Test each type of masonry and each type of stain. Test with the same equipment, recommended surface preparation and application procedures planned for general application. Let test area dry 3–7 days before inspection and approval. Make the test panel available for comparison throughout the cleaning project.

Dilution

Testing will indicate the proper dilution. Always pour cold water into empty bucket first, then carefully add product. Never use hot water. Handle in polypropylene buckets only. Acidic materials and fumes attack metal. Recommended dilutions for use on precast, monolithic and “unit” concrete surfaces:

Exposed Aggregate

- Removal of retarder, efflorescence, etc.
1 part concentrate : 2 parts water

Form-Finished Concrete

- Rough-texture: 1 part concentrate : 2 parts water
- Standard finish: 1 part concentrate : 3 parts water

Cast Simulated Stone/Manufactured Stone

1 part concentrate : 3 parts water

Concrete Block, Slump Brick, Concrete Brick

1 part concentrate : 3 parts water

Architectural Smooth-Finished Concrete

1 part concentrate : 6 parts water

BEST PRACTICES

Clean masonry before installing windows, doors, finished flooring, metal fixtures, hardware, light fixtures, roofing materials and other non masonry items.

Protect wall cavities during construction to prevent rainwater saturation and related staining. Let newly constructed surfaces dry and cure thoroughly before cleaning. Excessive moisture may mobilize staining and cause unsatisfactory cleaning results.

Apply with a soft-fibered, tampico masonry washing brush or with low-pressure spray equipment fitted with acid-resistant hoses and gaskets. Do not use pressure spray above 50 psi, as this drives the cleaner into the surface, making rinse difficult.

Rinse with enough water and pressure to flush spent cleaner and dissolved soiling from the

masonry surface and surface pores without damage. Inadequate rinsing leaves residues which may stain the cleaned surface.

For sensitive manufactured stone, rinsing pressures greater than 400 psi and fan spray tips smaller than 15° may permanently damage the surface.

For porous masonry, washing equipment generated 400–1000 psi with a water flow rate of 6–8 gpm is the best water/pressure combination for rinsing porous masonry. Use a 15–45° fan spray tip. Heated water (150–180° F; 65–82° C) may improve cleaning efficiency. Use adjustable equipment for reducing water flow-rates and rinsing pressure as needed for sensitive surfaces.

Never go it alone. For problems or questions, contact your local PROSOCO distributor or field representative. Or call PROSOCO technical Customer Care toll-free at 800-255-4255.

Product Data Sheet

Sure Klean® Light Duty Concrete Cleaner

Typical Coverage Rates

Reference the Substrate Chart on page 2. The coverage rate chart assumes an average coverage rate of 100 square feet per gallon of prepared cleaner.

When calculating the volume of cleaner required for porous, textured surfaces, assume 50 square feet per gallon of prepared cleaner.

For dense, smooth surfaces, assume up to 150 square feet per gallon of prepared cleaner.

Application Instructions

Multiple applications may etch acid-sensitive surfaces.

1. Working from the bottom to the top, always prewet surface with fresh water. When cleaning vertical surfaces, keep lower areas wet to avoid streaks.
2. Apply cleaner directly to surface with recommended masonry brush or low-pressure spray.
3. Let cleaner stay on the surface for 3–5 minutes or until stains are gone. Do not let cleaner dry on the surface, staining may result. If drying occurs, lightly wet treated surfaces with fresh water and reapply in a gentle scrubbing manner. If treated surfaces are left unattended, keep people away from the cleaner.
4. Reapply cleaner and rinse thoroughly with fresh water, working from the bottom to the top, to get all residues off the surface. If pressure rinsing equipment is not available, brush the surface while rinsing with clean water.

NOTE: Use only enough water to remove the spent cleaner and dissolved soiling from the surface. For manufactured stone, if tests show that pressure rinsing equipment can be used without removing color, do not exceed 400 psi.

Cleanup

Clean tools and equipment using fresh water.

WARRANTY

The information and recommendations made are based on our own research and the research of others, and are believed to be accurate. However, no guarantee of their accuracy is made because we cannot cover every possible application of our products, nor anticipate every variation encountered in masonry surfaces, job conditions and methods used. The purchasers shall make their own tests to determine the suitability of such products for a particular purpose.

PROSOCO, Inc. warrants this product to be free from defects. **Where permitted by law, PROSOCO makes no other warranties with respect to this product, express or implied, including without limitation the implied warranties of merchantability or fitness for particular purpose.** The purchaser shall be responsible to make his own tests to determine the suitability of this product for his particular purpose. PROSOCO's liability shall be limited in all events to supplying sufficient product to re-treat the specific areas to which defective product has been applied. Acceptance and use of this product absolves PROSOCO from any other liability, from whatever source, including liability for incidental, consequential or resultant damages whether due to breach of warranty, negligence or strict liability. This warranty may not be modified or extended by representatives of PROSOCO, its distributors or dealers.

CUSTOMER CARE

Factory personnel are available for product, environment and job-safety assistance with no obligation. Call 800-255-4255 and ask for Customer Care – technical support.

Factory-trained representatives are established in principal cities throughout the continental United States. Call Customer Care at 800-255-4255, or visit our web site at www.prosoco.com, for the name of the PROSOCO representative in your area.

Benefits of Post-Applied Water Repellent



The use of a post-applied water repellent is part of an overall strategy to comply with Code requirements for weather protection by providing excellent resistance to moisture penetration. A sound moisture strategy also includes following these additional recommendations:

First, the concrete masonry units and mortar should include integral water repellent. Second, flashing and weeps should be placed above any interruption of the vertical drainage cores in the wall to assure that the wall drains properly. Third, this drainage system is optimized by using CPG's WCT (which stands for "water control technology") products, which continually directs water downward in the cores in the wall so that the water drops and exits the wall via the flashing and weep system.

Why a Post-Applied Water Repellent?

The use of integral water repellent in the block and mortar drastically reduces the water that can enter the wall via the block and mortar joints. However, adding a post-applied water repellent provides even greater protection against moisture penetration. Here's why: the integral water repellent in the block and mortar does not prevent moisture entering through hairline cracks or small voids in the wall. These voids may be caused by unanticipated settlement cracks, small voids in the mortar, or movement cracks above openings. A clear, colorless, breathable post-applied water repellent can bridge such small voids.

As an added benefit, post-applied water repellents also help to keep the wall clean by reducing the volume of dirt and airborne pollutants that can build up on the wall surface. The water repellent should be applied using the manufacturer's instructions. Take note of the recommended coverage rate for concrete masonry, which typically may vary between concrete masonry and clay brick. If the proper amount of sealer isn't applied, the performance and life expectancy of the sealer will be compromised. We suggest measuring off a 100 sq. foot section to verify proper application rates as part of the sample process.

QUICK POINTS

- We recommend the use of a clear, colorless, breathable penetrating water repellent sealant as part of a comprehensive moisture control strategy using WCT units and flashing and weeps.
- The integral water repellent in the block and mortar addresses most moisture penetration; the post-applied sealant helps with if there are any small voids in the wall.
- Application of the sealant should be demonstrated and accepted on the sample panel prior to application on the main walls.

When to Apply

It is important not to apply a sealer until the walls have been cleaned, allowed to dry, and the cleaning results have been approved. If water repellents are applied onto walls with significant stains, the stains will still be visible after the coating has been applied.

It is difficult to go back and re-clean sealed masonry as the sealer must be stripped off the wall first, a difficult task to accomplish without damaging the masonry.

Demonstrate Sealants on the Sample Panel First

The jobsite sample panel is an easy and effective tool to avoid this problem. The application of the water repellent should be done after the panel segment has been cleaned and the cleaning method approved.

Following this sequence prior to wall construction allows the sample panel to demonstrate, and be the basis for approval of, how the wall will look after application.

As with cleaning methods, it is a bad idea to apply any material to the entire wall without testing it first on a test wall section to make sure the application will be approved and not have any detrimental effects on the wall.

For example, if for some reason the use of an inappropriate sealer causes unwanted changes in the color of the test section after application, it is a lot better to catch that on the sample panel than to have to figure out how to fix the color of the whole building. Clear, colorless sealers are readily available to avoid this problem.

Specification Considerations

We recommend that you use a colorless, non-staining, non-yellowing, breathable, and penetrating water repellent to be applied to the surface of the concrete masonry walls after they have been cleaned and accepted. The water repellent should be capable of performing over hairline cracks and small voids less than 1/16".

Our Concrete Product Group locations may inventory different water repellents. Contact the CPG manufacturer supplying the project for the water-repellent they recommend in their region of the country.

Conclusion

Single Wythe walls are extremely cost-effective compared to other systems. Adding a high quality post applied water repellent provides a layer of redundancy to protect the wall and does not add significant cost to structural single wythe masonry buildings.



Questions?

For more information, visit concreteproductsgroup.com or email your questions to info@concreteproductsgroup.com

MONOCHEM

TECHNICAL BULLETIN

AQUASEAL ME 12[®]



POSITIVE WATERPROOFING FOR CONCRETE & MASONRY

MADE IN U.S.A.

PRODUCT DESCRIPTION:

ITEM NO. 5200

AQUASEAL ME12 is a water-based, ready to use, Silane Oligomeric Alkyl Alkoxysiloxane micro emulsion solution. **AQUASEAL ME12** forms a colorless, non-staining, non-yellowing, breathable, deep penetrating water repellent for concrete and masonry. It is designed for use on above grade exterior/interior **VERTICAL** applications. **AQUASEAL ME12** effectively reduces seepage through the sound surface to which it is applied.

AQUASEAL ME12 can be used on porous substrates to protect against the damaging effects of water, de-icing chemicals, freeze-thaws, acid rain exposure and other atmospheric chemicals without altering or changing the texture or the surface appearance.

ADVANTAGES:

- Complies with all states VOC requirements.
- Excellent water repellency for up to ten years.
- Breathable and permeable to water vapor.
- Paintable with latex or oil based paints.
- Prevents future deterioration by natural causes.
- Helps stop concrete dusting and stucco spall off.
- Helps control alkali efflorescence and prevents water from leaching through sound surfaces.
- As an additive to latex paint: one (1) pint per gallon of latex paint gives better adhesion, more protection and better washability of paint.
- As a semi-transparent color sealer: one (1) part latex paint mixed with five (5) parts of **AQUASEAL ME12**.
- As a solid color sealer: 1st coat: Mix one (1) part of latex paint to five (5) parts of **AQUASEAL ME12**. 2nd coat: Mix one (1) part **AQUASEAL ME12** to five (5) parts of latex paint.
- As an underseal, it lengthens the life and color of paint while preventing saponification (blistering and flaking of paint on the surface).

PREPARATION:

1. The cause of the water infiltration must be determined. The substrate should be inspected to identify repairs or improvements which are necessary prior to application.

Excess Moisture: The source of moisture intrusion (ex. Condensation, settling, cracks, plumbing leaks, hydrostatic pressure, settling cracks, earthquake movements) into the building must be corrected prior to the application of **AQUASEAL ME12**.

2. **AQUASEAL ME12** should not be used as a substitute for additional details which may be required by Model or applicable Building Codes or Industry Recommendations such as the use of flashing, screeds, weep holes, weep tubes, vents, or additional back-up moisture control systems. Relative to Masonry, it should be considered a water repellent only.
3. Caulk and fill cracks, holes, voids, etc. larger than hairlines (1/16").
4. Treat or clean alkali, lime or efflorescence on the surface with a proper neutralizing agent. Allow 24 to 48 hours to dry before application.

TECHNICAL DATA:

Composition	Silane / Siloxane Oligomeric
Active solid by weight (ASTM D2369)	12% ±2
Weight per gallon	8.31 Lbs
VOC Level	< 32 g/L
Penetration	3/8 inch Minimum
Reduction in Water Leakage (ASTM E514)	.99% reduction
Moisture Vapor Transmission	
(ASTM E 96)	83-95% Minimum
(ASTM D 1653-03)	86-96% Minimum
Accelerated Weathering 2500 hrs (ASTM G154)	No loss in repellency
NCHRP 244 Series II (AASHTO T259 & AASHTO T260)	
Reduction of Water Absorption	.86%
Reduction in Chloride Ion	.92%
NCHRP 244 Series IV	
Reduction in Chloride Ion	.95%
Scaling Resistance 100 Cycles	
(ASTM C 672)	Zero, No Scaling
Water Repellency (Absorption)	
(ASTM C 67)	.97.6% Reduction
(SS-W-110-C) US Federal Spec.	.97.0%
(ASTM C 140)	.90% Effective
(ASTM C 642) @ 48 Hours	.90% Effective
Efflorescence Resistance (NBS 883)	Rated Highest
Surface Appearance	No Change
Warranty	Ten Years

OUTDOOR EXPOSURE TESTS:

UV Resistance	Excellent
Oxidation Resistance	Excellent
Pollution Resistance	Excellent
Dust Resistance	Excellent
Polymerized Content	Excellent
Water Resistant	Excellent

5. All preparation, painting, and caulking of joints or cracks should be allowed to cure prior to application.
6. Cure new concrete 28 days before application.
7. Do not apply **AQUASEAL ME12** to a wet surface. All surfaces must be dry for a minimum of 24 hours following rain. Moisture level should not exceed 15%.
8. In hot, dry weather it is recommended that the surface be slightly damp before application to improve material penetration.

LIMITATIONS:

AQUASEAL ME12 does not form a water-proofing membrane and does not seal inaccessible areas. It will not bridge cracks, fill large pores or compensate for flawed construction. Exposed walls must be capped and the backside of parapet walls must be sealed, flashings must be in place and weep holes and drains installed and functioning (where applicable).



7 THERMAL AND MOISTURE PROTECTION

WATER REPELLENTS 07190

MONOPOLE INC.
UPDATED OCTOBER 2010



Manufacturer of
U.S. SPECIALTY COATINGS

4661 Alger Street • Los Angeles, CA 90039

Tel: 818-500-8585 • Fax: 818-502-0818

www.monopoleinc.com • Email: info@monopoleinc.com

APPLICATION:

- **AQUASEAL ME12** must be applied in a small area prior to doing the complete job to insure proper results and to determine the proper coverage and application procedures.
- Apply with a brush, roller or, for best results, use spray equipment such as a compressor driven airless, pump or Hudson type sprayer. Use low pressure (not to exceed 25 PSI), allowing excess material to run down 10 to 12 inches (back roll all rundowns) assuring enough product has penetrated the surface. TIP SIZE: .035 orifice.
- **AQUASEAL ME12** should be applied in a uniform manner that saturates the entire surface by using horizontal and vertical passes, working areas from top to bottom.
- **AVOID PUDDLING.** If puddles form, broom out.
- **AQUASEAL ME12** should be used in a one coat application unless the surface is very porous. For porous surfaces apply the 2nd coat "wet-on-wet" not exceeding 15 minutes between coats.

Masonry and Mortar Joints: Due to the adsorbent nature and design of certain masonry mortar joints (ex. recessed joints) an extra zoned application of **AQUASEAL ME12** is recommended (to ensure a proper seal) prior to proceeding with a more broadcast coating for each area to be protected.

AQUASEAL ME12 should be applied in a uniform manner. The 1st coat consists of a light fog spray that wets the entire surface and breaks the surface tension. The fog coat must be followed immediately with the flood coat to achieve maximum penetration. Allow the material to run down 10 to 12 inches and back roll it into the substrate.

AQUASEAL ME12 is to be used in a one coat application. If the surface is porous and an additional treatment is needed, a second coat should be applied after "wet on wet" within 15 minutes. Do not apply more material than can be absorbed into the surface. Excess material remaining may result in a glossy appearance that can alter the adhesion of subsequent applications of paints or other coatings.

LEED CREDITS
AQUASEAL ME12 qualifies for earning LEED® credits for Environmental Quality, EQ 4.1 Low-Emitting Materials, based on low contribution of VOC.

CAUTIONS:

- **AQUASEAL ME12** is not recommended for below grade waterproofing or where hydrostatic pressure is present.
- **AQUASEAL ME12** will not prevent water penetration or help control alkali efflorescence through unsound or cracked substrates.
- Do not apply in windy conditions or at temperatures below 40°F or above 90°F.
- Do not apply if rain is anticipated within 24 hours. Allow the surface to dry at least 24 hours after rains or until the surface moisture level is below 15%.
- Do not use **AQUASEAL ME12** as a clear sealer over wood products, in particular redwood, pine or cedar. It will create a reaction with the acidic resin and turn the surface darker. For best results, substitute **AQUASEAL 2** Water Base formula for all wood products.
- Protect shrubbery, plants, grass, glass, metal and other glazed surfaces during application. Clean drips, runs and overspray residue while still wet, using detergent and water. Dried material may require a solution of vinegar and water or petroleum distillates for removal.

STORAGE:

Store in temperatures between 40°F. to 85°F. Protect from freezing, moisture and direct sunlight.

SHELF LIFE:

One year in well protected storage.

SAFETY & FIRST AID:

Use in a well ventilated area or wear an air-supplied respirator. Always wear protective goggles and gloves. If inhaled, move immediately to fresh air. In case of skin or eye contact, flush immediately with water for 15 minutes. Remove contaminated clothing and shoes. Call a physician. Local, state and federal regulations should be consulted for proper-disposal-procedures.

GUARANTEE:

AQUASEAL ME 12 is backed by a five and ten year warranty. It is available on an individual job basis and must be approved before application. Contact Monopole's service centers for further information.

WARRANTY INFORMATION:

MONOPOLE believes that the information in this publication is an accurate description of the typical characteristics and/or uses of the product or products. It is your responsibility to thoroughly test the product in your specific application to determine its safety and performance capabilities. Since use of this product is beyond our control, MONOPOLE, INC. cannot assume any risk or liability for results obtained when not used according to our specifications and directions. Unless MONOPOLE provides a specifically written statement of fitness for a particular use, MONOPOLE'S sole warranty is that the product will meet its current sales specifications. MONOPOLE disclaims any other expressed or implied warranties, including the warranty of merchantability and fitness for use. Your exclusive remedy and MONOPOLE'S sole liability for breach of warranty is limited to a refund of the purchase price or replacement of any product proven to be defective. In no event shall the seller be liable for any loss of profits or other consequential damages, including labor charges.

COVERAGE RATE	
Coverage rate may vary considerably due to the porosity of the surface. Always test and approve with the project architect and/or building owner prior to doing the complete job.	
SUBSTRATE	COVERAGE
Mammoth Block	60-80
Split Face Block	50-70
Standard Block (ASTM C90-75 Grade N)	60-80
Old Brick	80-100
New Brick	110-140
Mexican Tiles	40-60
Porous Concrete	60-80
Aggregates	110-150
*Concrete blocks and other rough and porous substrates (Vertical) will require 2 coats of AQUASEAL ME 12 . Apply a second coat at the coverage rate of 100-140 sq/ft per gallon.	

Nationwide Availability

The Concrete Products Group LLC (CPG) consists of regional market leaders in the concrete products industry. The CPG is organized to provide consistent, top-quality products to regional and national customers.

800-789-0872

A-1 BLOCK
1617 South
Division Avenue
Orlando, FL 32805

AMCON CONCRETE PRODUCTS, LLC
2025 Centre Pointe
Blvd., Suite 300
Mendota Heights, MN
55120-1221

BARNES & CONE
P.O. Box 280
5894 Court St. Rd.
Syracuse, NY
13206-0280

BARRASSO AND SONS INC
160 Floral Park Street
Islip Terrace, NY
11752

BASALITE CONCRETE PRODUCTS LLC
605 Industrial Way
Dixon, CA
95620

DAGOSTINO BUILDING BLOCKS, INC.
1111 Altamont Avenue
Schenectady, NY
12303

FENDT BUILDERS SUPPLY
22005 Gill Rd,
Farmington, MI
48335

FIZZANO BROTHERS CONCRETE PRODUCTS, INC.
1776 Chester Pike
Crum Lynne, PA
19022-1299

JANDRIS BLOCK
202 High St.
Gardner, MA
01440

JOHNSON CONCRETE COMPANY
217 Klumac Road
Salisbury, NC 28144

LEE Building Products
4301 Industrial Drive
Bowling Green, KY
42101

ORCO BLOCK & HARDSCAPE
11100 Beach Blvd.
Stanton, CA
90680-0129

TEXAS BUILDING PRODUCTS
3261 Highway 108
Strawn, Texas 76454

WESTERN MATERIALS COMPANY
1202 South First
Street
Yakima, WA 98901

Manufacturing Locations



INNOVATIVE CONCRETE
MASONRY SYSTEMS

www.concreteproductsgroup.com

©2022 Concrete Products Group, LLC
All rights reserved. RD 05192022