



# Spec-Thermal<sup>®</sup> Pre-Insulated Masonry Detailing Guide

2025 Edition





**Spec-Thermal® Detailing Guide  
Pre-Insulated Single Wythe Walls  
2023 Edition**

**[www.concreteproductsgroup.com](http://www.concreteproductsgroup.com)**

**800-789-0872**

# Table of Contents

Spec-Thermal® Pre-Insulated Concrete Masonry	1
Available Colors and Finishes	2
Fully or Partially Grouted Construction?	3
Comprehensive Construction Details	4
Design with Masonry Modularity	5
Weather and Moisture Protection	6
Movement Control (Controlling Aesthetic Cracking)	9
Thermal Protection	10
Use Current Standards	12
Using Sample Panels	13
Other Design Resources	15
Construction Notes	16
Hi-R Construction Details	22
Hi-R	23
Hi-R Wall System Components	25
Detail 4-2000 – HI-R – CMU Foundation – Slab at Grade	26
Detail 4-2001 – HI-R – Foundation – Concrete	27
Detail 4-2002 – HI-R – Foundation – Fully Grouted HI-R Stem Wall	28
Additional Notes – Foundations	29
Detail 4-2100 – HI-R – Michigan Style Bond Beam Control Joint – Section View	30
Detail 4-2101 – HI-R – Michigan Style Bond Beam Control Joint – Plan View	31
Detail 4-2102 – HI-R – Control Joint with Gasket and Sash Unit	32
Detail 4-2103 – HI-R – Bond Beam	33
Detail 4-2104 – HI-R – Horizontal Joint Reinforcement	34
Additional Notes – Bond Beams and Joints	35
Detail 4-2120 – HI-R – Corner – 12X8X16 – CMU Fitting Course 1	36
Detail 4-2121 – HI-R – Corner – 12X8X16 – CMU Fitting Course 2	37
Detail 4-2122 – HI-R – Corner – 10X8X16 – CMU Fitting Course 1	38
Detail 4-2123 – HI-R – Corner – 10X8X16 – CMU Fitting Course 2	39
Additional Notes – Corners	40
Detail 4-2200 – HI-R – Window Head and Lintel	41
Detail 4-2201 – HI-R – Window Head and Lintel with Specialized HI-R Lintel Unit	42
Detail 4-2202 – HI-R – Window Jamb with CMU Fitting and Double Icon Inserts	43
Detail 4-2203 – HI-R – Window Jamb with CMU Single Icon Inserts	44
Detail 4-2205 – HI-R – Window Sill (4")	45

# Table of Contents

Detail 4-2206 – HI-R – Window Sill (8")	46
Additional Notes – Window Openings	47
Detail 4-2210 – HI-R – Door Head – HI-R Stretcher Used for Lintel	48
Detail 4-2211 – HI-R – Door Head – HI-R/HI-R-H Closed Bottom Lintel	49
Detail 4-2212 – HI-R – Door Jamb	50
Additional Notes – Door Openings	51
Detail 4-2301 – HI-R – Precast Plank – Bearing Wall	52
Detail 4-2302 – HI-R – Precast Plank – Non-Bearing Wall	53
Additional Notes – Planks	54
Detail 4-2310 – HI-R – Roof and Parapet – Bearing Wall	55
Detail 4-2311 – HI-R – Roof and Parapet – Non-Bearing Wall	56
Additional Notes – Roof Joist and Parapet	57
Detail 4-2320 – HI-R – CMU Pilaster – Plan View	58
Detail 4-2321 – HI-R – CMU Pilaster – Section View	59
Additional Notes – Pilaster	60
HI-R-H Construction Details	61
HI-R-H Pre-Insulated Wall Systems	62
HI-R-H Wall Components	64
Detail 4-3000 – HI-R-H – Concrete Foundation	65
Detail 4-3001 – HI-R-H – Foundation – CMU	66
Detail 4-3002 – HI-R-H – Foundation – HI-R-H Stem Wall Slab at Grade	67
Detail 4-3003 – HI-R-H – Foundation – HI-R-H Basement Wall	68
Additional Notes – Foundations	69
Detail 4-3100 – HI-R-H Bond Beam	70
Detail 4-3101 – HI-R-H Horizontal Joint Reinforcement	71
Detail 4-3109 – HI-R-H – Piers, Control Joints, and Jamb – HI-R-H Jamb Unit	72
Detail 4-3110 – HI-R-H – Piers, Control Joints, and Jamb – HI-R-H Jamb Unit – Hooked Rein.	73
Detail 4-3111 – HI-R-H – Control Joint – CMU Sash	74
Detail 4-3112 – HI-R-H – Control Joint – HI-R-H Sash/Jamb Unit	75
Detail 4-3113 – HI-R-H – Relief Joint – Continuous Reinforcement	76
Additional Notes – Bond Beams and Joints	77
Detail 4-3120 – HI-R-H – Corner – CMU Fitting – Course 1	78
Detail 4-3121 – HI-R-H – Corner – CMU Fitting – Course 2	79
Detail 4-3122 – HI-R-H – Corner – 12X8X16 HI-R-H and CMU Unit Cuts	80
Detail 4-3123 – HI-R-H – Corner – 10X8X16 HI-R-H – Course 1	81
Detail 4-3124 – HI-R-H – Corner – 10X8X16 HI-R-H – Course 2	82
Additional Notes – Corners	83

# Table of Contents

Detail 4-3200 – HI-R-H – Window Head and Lintel with Inverted HI-R-H Unit	84
Detail 4-3201 – HI-R-H – Window Head and Lintel with HI-R/HI-R-H Closed Bottom Lintel	85
Detail 4-3202- HI-R-H – Window Head and HI-R/HI-R-H Closed Bottom Lintel Unit	86
Detail 4-3203 – HI-R-H – Window Jamb with CMU Jamb	87
Detail 4-3204 – HI-R-H -Window Jamb with HI-R-H Sash/Jamb Unit	88
Detail 4-3204 – HI-R-H – Window Sill – 4" Sill	89
Detail 4-3205 – HI-R-H – Window Sill – 8" Sill	90
Additional Notes – Window Openings	91
Detail 4-3210 – HI-R-H – Door Head and Lintel with Inverted HI-R-H Unit	92
Detail 4-3211 – HI-R-H – Door Head and Lintel with HI-R/HI-R-H Closed Bottom Lintel Unit	93
Detail 4-3212 – HI-R-H – Door Jamb with HI-R-H Sash/Jamb Unit	94
Detail 4-3213 – HI-R-H – Door Jamb with CMU Jamb	95
Additional Notes – Door Openings	96
Detail 4-3300 – HI-R-H – Precast Plank Bearing Wall	97
Detail 4-3301 – HI-R-H – Precast Plank Non-Bearing Wall	98
Additional Notes – Planks	99
Detail 4-3310 – HI-R-H – Roof and Parapet – Bearing Wall	100
Detail 4-3311 – HI-R-H – Roof and Parapet – Non-Bearing Wall	101
Additional Notes – Roof Joist and Parapet	102
Detail 4-3320 – HI-R-H – CMU Pilaster Plan View	103
Detail 4-3321 – HI-R-H – CMU Pilaster – Section View	104
Additional Notes – Pilaster	105
HI-R Half High Construction Details	106
HI-R® Half High (Spec-Brik HI-R)	107
HI-R Half High Wall Components	109
Detail 4-4000 – HI-R Half High – CMU Foundation	110
Detail 4-4001 – HI-R Half High – Foundation – Concrete	111
Detail 4-4002 – HI-R Half High – Foundation Fully Grouted HI-R Stem Wall	112
Additional Notes – Foundations	113
Detail 4-4100 – HI-R Half High – Michigan Style Bond Beam Control Joint – Section View	114
Detail 4-4101 – HI-R Half High – Michigan Style Bond Beam Control Joint – Plan View	115
Detail 4-4102 – HI-R Half High – Control Joint	116
Detail 4-4103 – HI-R Half High – Bond Beam	117
Detail 4-4104 – HI-R Half High – Horizontal Joint Reinforcement	118
Additional Notes – Bond Beam/Joints	119
Detail 4-4120 – HI-R Half High – Corner – 12X8X16 – CMU Fitting Course 1	120
Detail 4-4121 – HI-R Half High – Corner – 12X8X16 – CMU Fitting Course 2	121

# Table of Contents

Additional Notes – Corners	122
Detail 4-4200 – HI-R Half High – Window Head & Lin-tel with HI-R Half High Units	123
Detail 4-4201 – HI-R Half High – Window Head & Lintel Using HI-R/HI-R-H Lintel	124
Detail 4-4202 – HI-R Half High – Window Jamb with CMU Jamb	125
Detail 4-4205 – HI-R Half High – 4" Sill	126
Detail 4-4206 – HI-R Half High – 8" Sill	127
Additional Notes – Window Openings	128
Detail 4-4210 – HI-R Half High – Door Head – HI-R Half High Stretcher Used for Lintel	129
Detail 4-4211 – HI-R Half High – Door Head – HI-R/HI-R-H Closed Bottom Lintel Unit	130
Detail 4-4212 – HI-R Half High – Door Jamb	131
Additional Notes – Door Openings	132
Detail 4-4300 – HI-R Half High – Precast Plank Bearing Wall	133
Detail 4-4301 – HI-R Half High – Precast Plank Non-Bearing Wall	134
Additional Notes – Planks	135
Detail 4-4310 – HI-R Half High – Parapet Bearing Wall	136
Detail 4-4311 – HI-R Half High – Parapet Non-Bearing Wall	137
Additional Notes – Roof Joist and Parapet	138
Detail 4-4320 – HI-R Half High – Pilaster Section View	139
Detail 4-4321 – HI-R Half High – Pilaster Plan View	140
Additional Notes – Pilaster	141
HI-R-H Half High Construction Details	142
Spec-Thermal® HI-R-H Half High	143
HI-R-H Half High Wall Components	145
Detail 4-5000 HI-R-H Half High – CMU Foundation	146
Detail 4-5001 – HI-R-H Half High – Concrete Foundation	147
Detail 4-5002 – HI-R-H Half High – HI-R-H Foundation	148
Detail 4-5003 – HI-R-H Half High – HI-R-H Foundation – Slab below grade	149
Additional Notes – Foundations	150
Detail 4-5100 – HI-R-H Half High – Bond Beam	151
Detail 4-5101 – HI-R-H Half High – Horizontal Joint Reinforcement	152
Detail 4-5109 – HI-R-H Half High – Piers, Control Joint and Jambs	153
Detail 4-5110 – HI-R-H Half High – Piers, Control Joint and Jambs – Hooked Rein.	154
Detail 4-5111 – HI-R-H Half High – Control Joint – CMU Sash	155
Detail 4-5112 – HI-R-H Half High – Control Joint – HI-R-H Half High Sash/Jamb Unit	156
Additional Notes – Bond Beams/Control Joints/Horizontal Joint Reinforcement	157

# Table of Contents

Detail 4-5120 – HI-R-H Half High – Corner – CMU Fitting – Course 1	158
Detail 4-5121 – HI-R-H Half High – Corner – CMU Fitting – Course 2	159
Detail 4-5122 – HI-R-H Half High – Corner – 12X8X16 HI-R-H and CMU Fitting Unit Cuts	160
Additional Notes – Corners	161
Detail 4-5200 – HI-R-H Half High – Window Head & Lintel with HI-R-H Half High Unit	162
Detail 4-5201 – HI-R-H Half High – Window Head & Lintel with HI-R/HI-R-H Closed Bottom Lintel Unit	163
Detail 4-5202 – HI-R-H Half High – Window Jamb with CMU Jamb	164
Detail 4-5203 – HI-R-H Half High – Window Jamb with HI-R-H Half High Sash/Jamb Unit	165
Detail 4-5204 – HI-R-H Half High – Window Sill – 4" Sill	166
Detail 4-5205 – HI-R-H Half High – Window Sill – 8" Sill	167
Additional Notes – Window Openings	168
Detail 4-5210 – HI-R-H Half High – Door Head and Lintel Using HI-R-H Half High Units	169
Detail 4-5211 – HI-R-H Half High – Door Head and Lintel Using HI-R/HI-R-H Lintel	170
Detail 4-5212 – HI-R-H Half High – Door Jamb – HI-R-H Half Jamb Unit	171
Detail 4-5213 – HI-R-H Half High – Door Jamb – CMU Jamb	172
Additional Notes – Door Openings	173
Detail 4-5300 – HI-R-H Half High – Precast Plank Non-Bearing Wall	174
Detail 4-5301 – HI-R-H Half High – Precast Plank Bearing Wall	175
Additional Notes – Planks	176
Detail 4-5310 – HI-R-H Half High – Parapet Bearing Wall	177
Detail 4-5311 – HI-R-H Half High – Parapet Non-Bearing Wall	178
Additional Notes – Roof Joist and Parapet	179
Detail 4-5320 – HI-R-H Half High – Pilaster Section View	180
Detail 4-5321 – HI-R-H Half High – Pilaster Plan View	181
Additional Notes – Pilaster	182
Generic CMU Details	183
Detail 4-0001 – CMU – Concrete Foundation – At Opening	184
Detail 4-0002 – CMU – Concrete Foundation – Loading Dock	185
Detail 4-0003 – CMU – CMU Foundation – Loading Dock	186
Detail 4-0004 – CMU – CMU Foundation – At Opening	187
Detail 4-0005 – CMU – HI-R-H Foundation – At Opening	188

## Spec-Thermal® Pre-Insulated Concrete Masonry

This manual focuses on how to detail wall systems using the Spec-Thermal® family of pre-insulated masonry products. Pre-insulated concrete masonry is a masonry wall system where insulation is factory installed in the concrete masonry units so that it is in place prior to the placement of reinforcement and grout to provide integral insulation in the finished wall assembly.

The products in the Spec-Thermal® family include the two-web HI-R and the one-web HI-R-H pre-insulated masonry wall systems. Both systems are also offered in half high versions (HI-R Half High and HI-R-H Half High).



**HI-R-H**  
**12×8×16**

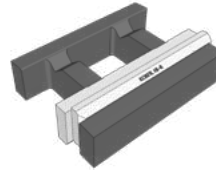

**HI-R Half High**  
**12×4×16**

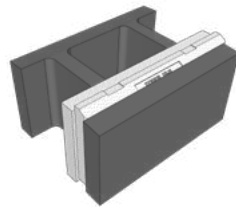

**HI-R**  
**12×8×16**

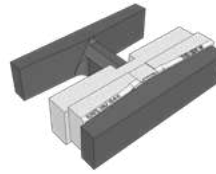

**HI-R-H Half High**  
**12×4×16**

### Spec-Thermal® Product Family

The Spec-Thermal® products allow the construction of insulated wall assemblies with double exposed architectural masonry surfaces. The systems are designed so that the insulation remains in place even where reinforcement and grout are placed so that there is no compromise to the wall's thermal performance.

Pre-insulated masonry unit system components:

- ASTM C-90 compliant Concrete Masonry Units designed to minimize thermal bridging by reducing the cross sectional area of the web(s) that cross from the exterior to the interior of the unit.
- Insulation inserts placed inside the unit, reducing thermal bridging. They are typically installed at the factory.
- The CMU, Mortar, Reinforcement and Grout act structurally in composite action (based upon Structural Engineer's criteria for load resistance).

## Available Colors and Finishes

Generally, the following textures are available by product, but please check with your local manufacturer to confirm local color and texture availability.

Product	Textures	Colors
HI-R 8X8X16*	Smooth, splitface, ground, blasted	Manufacturer's color range, Spec-Split colors, and Spec-Brik blends
HI-R 10X8X16	Smooth, splitface, ground, blasted	Manufacturer's color range; Spec-Split colors, and Spec-Brik blends
HI-R 12-8-16	Smooth, splitface, ground, blasted	Manufacturer's color range; Spec-Split colors, and Spec-Brik blends
HI-R Half High 12x4x16	Smooth, blasted	Manufacturer's color range; Spec-Split colors, and Spec-Brik blends
HI-R-H 10X8X16**/12X8X16	Smooth, splitface, ground,	Manufacturer's color range; Spec-Split colors, and Spec-Brik blends
HI-R-H Half High 12x4x16	Smooth, blasted	Manufacturer's color range; Spec-Split colors, and Spec-Brik blends

\* 8X8X16 HI-R typically is not specified for load-bearing applications. The groutable space is very restricted.

\*\*10-8-16 HI-R-H is available only regionally; check availability before specifying.

## Spec-Brik Color Blends

The colors below are available nationally, along with our manufacturer's standard color selections. CPG offers software and a Revit® plug-in at <https://concreteproductsgroup.com/innovation/masonry-designer> to assist in rendering designs using these colors.



Basalt Blend



Chesapeake Blend

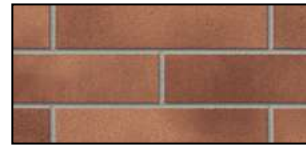

Delaware Blend



Dixon Blend



Flint Blend



Gardner Blend



Houston Blend



Jefferson City Blend



Panama City Blend



Philadelphia Blend

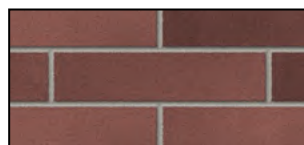

St. Cloud Blend

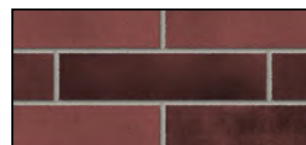

Stanton Blend

The colors above are digital renderings of blended Spec-Brik colors. We recommend viewing a sample board before making color selections and using a job site sample panel as the basis for acceptance of the final work.

## Fully or Partially Grouted Construction?

With the Spec-Thermal® family of products, full or partial grouted load-bearing walls are readily constructed as either single or multi-wythe systems. The HI-R products are suitable for both partially grouted and fully grouted walls. The HI-R-H products are suitable only for fully grouted construction, with a design which facilitates grout flow throughout the wall by minimizing obstructions.

Here are some considerations regarding the choice between single wythe full or partial grouting:

Full Grout	Partial Grout
<p><b>Construction:</b> Simpler construction process - all cores are grouted and flashing is only needed at sills of openings and the top of the wall, if not protected by the roof assembly. For heavily reinforced walls, full grout is often the most efficient choice.</p>	<p><b>Construction:</b> Requires less grout material and associated labor costs. As reinforcement spacing increases, the cost savings for partial grout become more significant, though additional costs are required for flashing/weeps and an air barrier strategy</p>
<p><b>Air barrier:</b> Solid grouted walls are deemed by Code to comply with air barrier requirements, so no additional air barrier is required.</p>	<p><b>Air barrier:</b> Additional air barrier strategy is required. Options include interior or exterior surface coatings, parges, stucco, plaster, sealed wallboard, etc.</p>
<p><b>Thermal:</b> Greater mass from a solid grouted wall optimizes thermal mass benefits of masonry.</p>	<p><b>Thermal:</b> UngROUTED portions of the wall will have slightly higher R-Value than grouted portions. The overall U-Factor and Heat Capacity for the assembly will be the weighted average of grouted and ungrouted areas plus contributions from other wall assembly elements</p>
<p><b>Moisture Penetration Resistance:</b> Multiple barriers (post-applied water repellent sealer on exterior surface; integral water repellent in block and mortar; and solid grouted cores). In California, it is typical not to use integral water repellent in the block and mortar.</p>	<p><b>Moisture Penetration Resistance:</b> Barriers and core drainage (post-applied water repellent sealer on exterior surface; integral water repellent in block and mortar; and flashing and weeps system to facilitate drainage from the cores of the walls to the exterior).</p>
<p><b>Fire Resistance*:</b> Fire Rating for Solid grouted walls with 12" units will typically exceed 4 Hours.</p>	<p><b>Fire Resistance*:</b> Varies by unit width and density of ungrouted wall portions.</p>

\* check with manufacturer for unit specific fire rating information.

Even in regions where partially grouted construction is the norm, the designer should consider the advantages of solid grouting as it often is the best solution, particularly for heavily reinforced walls.

## Comprehensive Construction Details

This Guide includes a set of construction details for how to detail a variety of common elements for pre-insulated masonry walls.

The details are guided by several overall design considerations that are key to success:

- ▷ Incorporating masonry modular dimensions
- ▷ Weather and moisture protection
- ▷ Movement control
- ▷ Thermal protection
- ▷ Use of the most current standards for concrete masonry
- ▷ Use a job site sample panel



**HI-R and HI-R-Half High wall under construction  
(shown prior to tooling joints)**



## Weather and Moisture Protection

The details in this manual are based on a comprehensive approach to moisture control (some might refer to this as a “belt and suspenders” approach) for long-lasting performance. Spec-Thermal® walls can be designed as full or partial grout structures (use HI-R for partial grout structures), and the weather and moisture protection strategies will differ in some respects for these two wall types.

Both wall types may use some or all of these fundamentals:

### Surface Protection

- ▷ Properly tooled mortar joints
- ▷ Post-applied penetrating breathable water repellent –or–
- ▷ Post-applied exterior breathable film forming coatings
- ▷ Masonry appropriate elastomeric joint sealants
- ▷ Masonry accessories

### Internal Protection

- ▷ Integral water repellents in CMU and mortar
- ▷ Non-absorptive Integral Insulation
- ▷ Joint and structural reinforcement (movement and crack control design details)
- ▷ Moisture collection, drainable flashing, drainable drip edges, drainable weeps, and drainable vent systems
- ▷ Vestibules, and roof or window projections (external)
- ▷ Building aprons (external)

The wall systems presented in this manual can be fully grouted or partially grouted (the HI-R-H system is available only with full grout). Typically the two approaches will be similar in cost, and fully grouted structures may offer a simpler approach to moisture control. Fully grouted structures also do not require flashing, weeps, drainage tubes or vents except possibly adjacent to certain wall openings and at the top of the wall.

## Weather and Moisture Protection, cont.

The main difference between fully and partially grouted single wythe walls in terms of moisture management is the use of flashing at bond beams and other interruptions in the drainage plane within a partially grouted wall. In a partially grouted wall, some of the cores in the CMU will be empty. These empty cores are a path for vertical drainage of any moisture that is in the wall. When these open cores meet an interruption, such as a bond beam, the moisture is collected by flashing and exits to the exterior of the wall via weeps.

**Partially Grouted HI-R or HI-R Half High Walls:** The details for these systems in this manual will typically note where flashing should be placed in relation to bond beams, lintels, and other locations where flashing should be used. Properly flashing masonry walls is a key strategy for partially grouted walls to ensure that the wall assembly resists moisture penetration. There are many types of flashing available today, each with its own characteristics. This Guide assumes design and construction compliance with applicable Building Codes. Further, and when applicable, the Guide assumes the use of flashing with partially grouted walls. There is an extensive discussion of weather protection and moisture management for partially grouted single wythe walls in the Spec-Brik Detailing Manual, available at <https://concreteproductsgroup.com/resources/technical-documents-library>.

**Fully grouted HI-R and HI-R-H walls (including half high versions)** are a barrier wall for weather protection and moisture management purposes. There is no need to provide flashing other than at the sills of openings in the wall and at the top of the

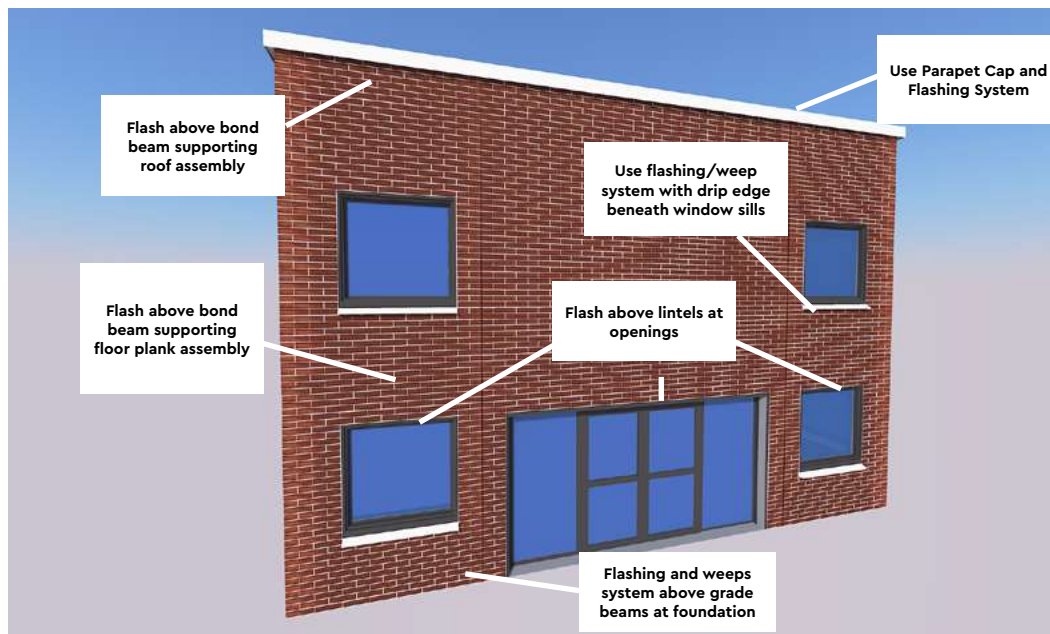

Flashing locations for a partially grouted wall

## Weather and Moisture Protection, ctd.

parapet. For fully grouted walls, the use of Integral Water Repellent in the block and mortar is a typical approach to weather and moisture protection. We also recommend the use of a post-applied water repellent over the exterior surface of the wall following installation, curing, and approved cleaning.

Designers for projects in **California** should consult local practice regarding the use of Integral Water Repellent in concrete masonry walls. If it is not used, a post-applied water repellent should be considered to provide protection from water penetration of the wall.

Concrete masonry walls are not prone to moisture damage and are not a food for mold. In fact, CMU walls are recommended by FEMA guidelines for use in flood zones because of their ability to remain in service after cleanup following a flood event.

For aesthetic reasons, it is very important to prevent moisture entering at the top of all masonry during construction. This is a TMS 602 requirement. Allowing such penetration can lead to the formation of efflorescence. This is true for both partially and fully grouted walls. Be sure to protect the top of the wall during breaks in construction all the way until a permanent flashing/cap or protective roof is installed. Often this is overlooked at the juncture where the wall is completed but the permanent roof or parapet cap has not yet been installed.



**Protective covering prior to permanent capping of the wall  
This is also done by securely tarping the wall top**

## Movement Control (Controlling Aesthetic Cracking)

The wall design should use movement joints (also known as control joints in this context) and horizontal reinforcement (using reinforced bond beams alone or in combination with horizontal joint reinforcement) to control aesthetic cracking. The construction details section of this manual discusses both.

The spacing of control joints needs to be carefully addressed to provide adequate crack control but also to maximize efficiency during wall construction. The project engineer will include details for the spacing and placement of structural control joints. Placing the joints with masonry modular dimensions will improve efficiency.



**Control Joint using HI-R-H Half-High Jamb Unit and Pre-Formed Gasket**

## Thermal Protection

Increasingly, Energy Codes drive design decisions as requirements become more stringent. Traditional concrete masonry walls will not meet these requirements in many climate zones without some form of supplemental insulation.

There are many applications where it is highly desirable to have durable masonry architectural surfaces on both the exterior and interior of the wall. The traditional mainstay, the CMU/Veneer cavity wall, remains an excellent choice for Energy Code compliance, but constructing a cavity wall is more expensive than building a single wythe masonry wall – typically the cost is 30+% higher.

### Typical HI-R and HI-R-H Applications

Water Treatment Facilities	Bus Garages
Schools	Parking Structures
Athletic Facilities/Stadiums	Indoor Swimming Pool Facilities
Gymnasiums	Single Family Housing
Concession Stands	Cold Storage Facilities
Retail and Grocery Stores	Auditoriums and Music Venues
Multi-Residential Buildings	Film Production Stages
Detention Facilities	Public Safety Buildings (Police and Fire)
Manufacturing Facilities/Warehouses	Public Maintenance Facilities
Automotive Service Centers	

For these types of projects, the designer should consider using Spec-Thermal® pre-insulated masonry to provide Code-compliant thermal performance and concrete masonry finishes on both the interior and exterior of the wall.

**Air Barrier Considerations:** Full grout is deemed to comply with the International Energy Conservation Code's air barrier requirements. When partially grouted, several Code-based and empirically proven methods, including application of wall board with sealed joints, block fillers, paints, coatings, parging, stucco, etc. can be employed to provide an air barrier.

As the chart on the following page shows, the Spec-Thermal® product family offers a variety of solutions that are applicable to most climate zones.

## Thermal Protection, ctd.

The chart below summarizes the thermal values for the product family. For more details, see CPG Thermal Properties Guide (see link on page 15). The CPG Thermal properties guide provides complete thermal properties for all sizes and shapes. Consult local CPG producer for available sizes and shapes and densities in your region. The aggregates that are available in a region may limit which CMU color and density options are available.

<b>R-Values and U-Factors for HI-R and HI-R-H Masonry Units (Stretcher units only/regionally available densities vary)</b>					
<b>Product (grouted cells)</b>	<b>Density (pounds per cubic foot)</b>				
	<b>95</b>	<b>105</b>	<b>115</b>	<b>125</b>	<b>135</b>
<b>HI-R Two Webs, 2.5 inch insert 8X8X16*</b>	<b>U-0.10 R-10.00</b>	<b>U-0.110 R-9.07</b>	<b>U-0.122 R-8.18</b>	<b>U-0.136 R-7.36</b>	<b>U-0.152 R-6.59</b>
<b>HI-R Two Webs, 2.5 inch insert 10-8-16</b>	<b>U-0.085 R-11.82</b>	<b>U-0.092 R-10.82</b>	<b>U-0.10 R-9.85</b>	<b>U-0.11 R-8.94</b>	<b>U-0.124 R-8.08</b>
<b>HI-R and HI-R Half High Two Webs, 2.5 inch insert 12X8X16/12x4x16</b>	<b>U-0.079 R-12.58</b>	<b>U-0.087 R-11.56</b>	<b>U-0.095 R-10.57</b>	<b>U-0.104 R-9.62</b>	<b>U-0.115 R-8.72</b>
<b>HI-R-H One Web, 3.0 Inch Insert 12X8X16</b>	<b>U-0.066 R-15.08</b>	<b>U-0.072 R-13.84</b>	<b>U-0.079 R-12.70</b>	<b>U-0.087 R-11.55</b>	<b>U-0.096 R-10.39</b>
<b>HI-R-H One Web, 3.5 inch insert 10X8X16**</b>	<b>U-0.066 R-15.11</b>	<b>U-0.073 R-13.70</b>	<b>U-0.080 R-12.57</b>	<b>U-0.088 R-11.37</b>	<b>U-0.098 R-10.17</b>
<b>HI-R-H One Web, 3.5 inch insert 12X8X16</b>	<b>U-0.061 R-16.32</b>	<b>U-0.067 R-14.98</b>	<b>U-0.073 R-13.74</b>	<b>U-0.080 R-12.50</b>	<b>U-0.089 R-11.25</b>
<b>HI-R-H One Web, 4 inch insert 12X8X16</b>	<b>U-0.057 R-17.56</b>	<b>U-0.062 R-16.12</b>	<b>U-0.068 R-14.78</b>	<b>U-0.074 R-13.45</b>	<b>U-0.083 R-12.11</b>
<b>HI-R-H Half High One Web, 4 inch insert 12x4x16</b>	<b>U-0.056 R-17.87</b>	<b>U-0.061 R-16.40</b>	<b>U-0.067 R-15.04</b>	<b>U-0.073 R-13.69</b>	<b>U-0.081 R-12.32</b>

\* 8X8X16 HI-R typically is not specified currently for load-bearing applications. The groutable space is very restricted.

\*\* Check with your local CPG representative; 10" version has regional availability only.

As an example, the 2021 IECC prescriptive requirements for mass walls for commercial buildings require that the U-Factor for mass walls not exceed the following values per climate zone (applicable Code for your project will be based on the requirements of the Authority Having Jurisdiction):

Climate Zone	1	2	3	4	5	6	7	8
U-Factor	U-0.151	U-0.151	U-0.123	U-0.104	U-0.090	U-0.080	U-0.071	U-0.037
U-Factor (Group R)	U-0.151	U-0.123	U-0.104	U-0.090	U-0.080	U-0.071	U-0.071	U-0.037

## Use Current Standards

There have been some dramatic increases in concrete masonry design efficiency within the last decade.

As a result it is a good idea to have a concrete masonry specialist review your firm's master masonry specification to make sure that it conforms to the latest industry standards.

One simple change has been to the strength requirement for concrete masonry. To this day, many specifications we review still use a standard of 1900 psi for load bearing masonry. This allows a f'm of 1500 psi to be used for the masonry design. After recalibration based on extensive research, the 2013 Building Code Requirements for Masonry Structures recognized 2,000 psi CMU Walls Using Type S Mortar as having a 2,000 psi f'm compressive strength. This is 33% stronger! This has the practical impact of reducing the amount of reinforcement that is required – driving cost reduction.

## Using Sample Panels

The jobsite sample panel is an invaluable way to assure project quality.

In general, the designer should follow the requirements of the most current edition of the "Building Code Requirements and Specification for Masonry Structures"

The jobsite sample panel must be constructed and approved before the masonry work begins on the project and remain available for inspection until project completion. All samples and submittals except the mortar color must be approved before the jobsite sample panel is constructed. Field constructed sample panels should not be used to select or accept colors or texture of masonry units.

Mortar joint color and tooling greatly influence the finished appearance of the wall and the appearance of the tooled joints must be approved in the sample panel.

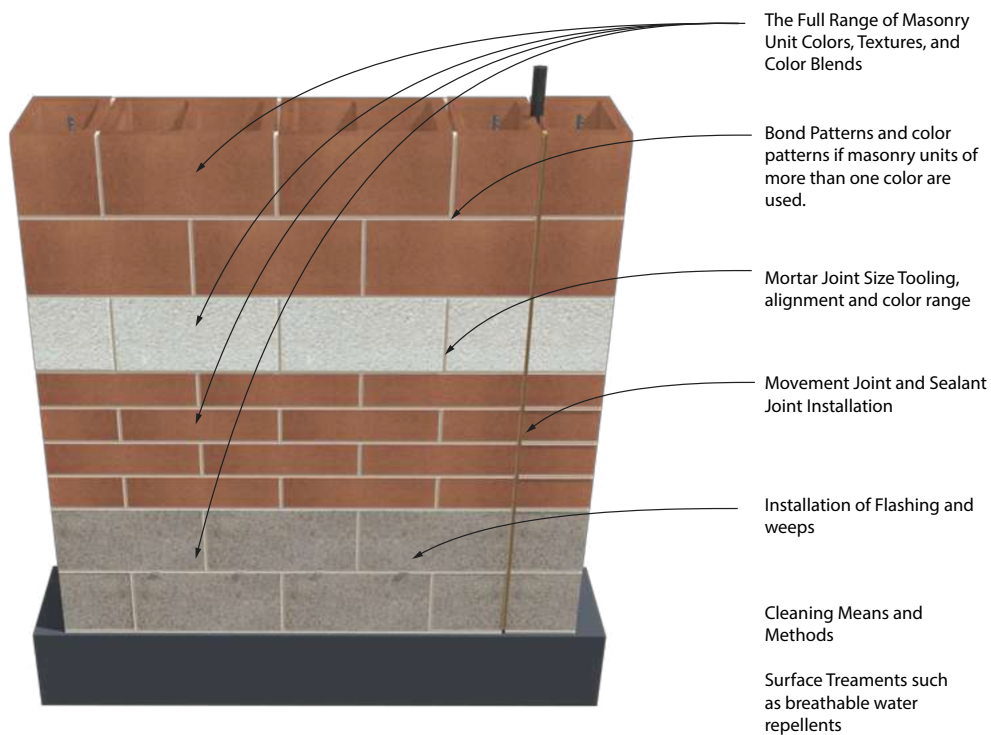

## Using Sample Panels, Ctd.

Construct the sample panel on the jobsite at a highly visible location where it will not be disturbed before the completion of this project. Use only the materials that were approved in the submittal review and masonry units that were already manufactured for this project.

The contractor should place orders for jobsite sample panel materials with masonry producers so that they have advance notice to manufacture and collect the full range of color for the building for shipment on a separate pallet.

The minimum size of the sample panel dimensions must be at least 4 ft. by 4 ft. A larger panel may allow more options to test cleaning and sealing. One approach is to build a sample panel that is 4ft by 8ft in order to demonstrate how the wall looks both before and after cleaning and surface treatments.

The purpose of jobsite sample panel is to show the acceptable standard of work for the project and it must include:

- ▷ The full range of masonry unit color and texture that will be visible in the finished walls.
- ▷ Bond pattern and color pattern if masonry units of more than one color are being used.
- ▷ Chippage dimensions and frequency including dimensional variation per project specifications.
- ▷ Mortar joint size, tooling, alignment, texture and color range.
- ▷ If colored mortar is used, the color must be judged after the sample panel has had sufficient time to dry.
- ▷ Installation of flashing, weeps, drip edge and sealant joint.
- ▷ Control joint installation and sealant joint
- ▷ Cleaning means and methods.
- ▷ Surface treatments such as breathable sealers.

The sample panel will be used for final acceptance of the masonry work and must remain unharmed until the masonry is complete and accepted. The Masonry Code charging language states:

***"The acceptable standard for the Work is established by the accepted panel."***

The sample panel will be viewed from a distance of 20 feet away under diffused lighting to evaluate the results.

## Other Design Resources

### Thermal Properties Guide

The Thermal Properties Guide provides thermal values for the Spec-Thermal® product family, including all fittings needed to build typical walls, such as joints, jambs, and corners. The guide also includes a discussion of how to select the best product for your project. The guide is available at this link:

[CPG Thermal Properties Guide](#)

### Design Resource Center

The Concrete Products Group has a dedicated website to provide designers access to design tools, the Design Resource Center. The site includes a variety of resources including downloadable versions of the details in this manual in AutoCAD® or Revit formats, our Masonry Designer color catalog and Revit Plug-in, design and construction notes and videos, and other helpful resources. We also have provided a guide specification on the site that is available for download.

[Design Resource Center Access Page](#)

### Masonry Designer Software and Revit® Plug-in

Masonry Designer Software software allows designers to render wall sections with all CPG products and colors, including Spec-Brik, Spec-Block (grey CMU), and Spec-Split (Architectural Split face CMU). The program allows selection of both block and mortar colors, and allows experimentation with combinations of different colors and textures. A Revit® Plug-in is available from the same site to facilitate rendering models with the Spec-Brik® colors.

[Masonry Designer Software and Revit® Plug-in](#)



---

# Construction Notes

---

## Spec-Thermal® HI-R and HI-R-H Construction Notes

The following tips should be used for best results when building walls using HI-R and HI-R-H Wall Systems.

### Unit and Mortar Dimensions

The HI-R and HI-R-H systems are designed to use a 3/8" mortar joint, head and bed. The units are 1/8" taller at the inside of the face shell (7-3/4") than at the outer face (7-5/8") so less mortar will be required for the bed joints than conventional CMU.

### Install the Units "Right Side Up"

HI-R/HI-R-H Units are pre-insulated at the manufacturer and will arrive at the job site with the insulation in place. Unlike standard CMU, these units are not inverted for installation. When the units are correctly oriented, the insert will rest on top of the webs as shown below.

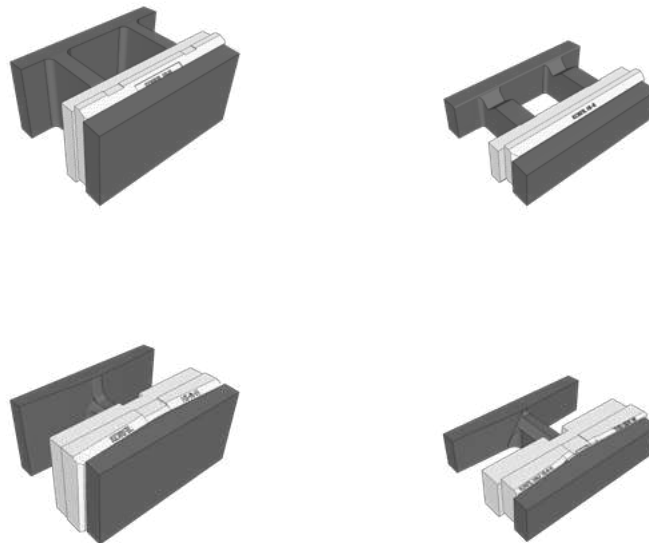

**This is how the units look "right side up"**

# Spec-Thermal® HI-R and HI-R-H Construction Notes

## Locate Insulation Inserts toward the Exterior of the Wall

Typically the blocks should be oriented so that the inserts are located toward the exterior of the wall, unless detailed otherwise on the contract drawings. The thermal values will be the same in either orientation.

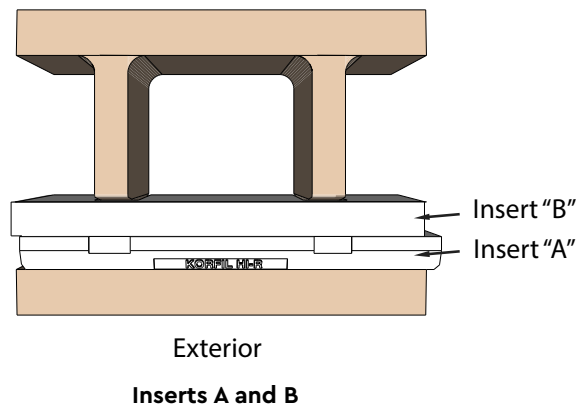

## Handling Inserts on the Starter Course

You will notice that the inserts have two interlocking parts which are referred to as the "A" insert (located toward the exterior of the block) and the "B" Insert (located toward the interior of the block). Carefully avoid leaving excess mortar under the "B" insert on the first course of block. Some masons prefer to remove the "B" insert on the starter course before placing the units and then to place the inserts after checking to make certain any mortar that may have fallen under the inner insert is removed. This is done to prevent height gain due to the mortar preventing the insert from being properly tapped down into position.

## After Laying Block, Tap Insert Down Into Place.

The A and B inserts are designed to form lapping joints when placed in the wall with blocks located above and below and to both sides to provide superior insulation. As you build each course, be sure to tap or push the "B" Insert downwards to position it correctly to form a tight joint with the inserts below. At the end of each work day, make sure the "B" Inserts on the top course are fully tapped down into place to avoid a height gain when work is recommenced.

## Spec-Thermal® HI-R and HI-R-H Construction Notes

### Grouting and Reinforcing Hi-R and HI-R-H Walls

The HI-R product is suitable for both full and partial grouting. The HI-R-H products are designed only for fully grouted walls. The webs in HI-R blocks will align when they are placed in either a running bond or stack bond pattern providing an unobstructed grout space for grouting and re-bar placement. The reduced height of the HI-R-H single web will allow grout to flow between units and is suitable for fully grouted walls in either running or stack bond patterns. When building partially grouted HI-R Walls, request that the webs be full height. This will eliminate the need to mortar the reduced height webs. Remember that all masonry grout lifts and pours are to be both consolidated and re-consolidated by Code, with the exception of self-consolidating grout.

Grout Volumes		
Unit	Grout volume per unit (cubic inches)	Grout ft <sup>3</sup> per ft <sup>2</sup> of wall area (fully grouted)
HI-R 8X8X16 Smooth/Split <sup>1</sup> (2.5 in. Insulation)	192.1	0.1344
HI-R 10X8X16 Smooth/Split <sup>1</sup> (2.5 in. Insulation)	368.0	0.2574
HI-R 12X8X16 Smooth/Split <sup>1</sup> (2.5 in. Insulation)	533.8	0.3734
HI-R 12x4x16 <sup>1</sup> (2.5 in. Insulation)	238.1	0.3504
HI-R-H 10X8X16 Smooth/Split <sup>1</sup> (3.5 in. Insulation)	299.3	0.2093
HI-R-H 12X8X16 Smooth/Split <sup>1</sup> (3.0 in. Insulation)	585.2	0.4093
HI-R-H 12X8X16 Smooth/Split <sup>1</sup> (3.5 in. Insulation)	499.2	0.3492
HI-R-H 12X8X16 Smooth/Split <sup>1</sup> (4.0 in. Insulation)	438.8	0.3069
HI-R-H 12X8X16 Jamb Unit <sup>1</sup> (4.0 in. Insulation)	369.4	0.2584
HI-R-H Half High 12x4x16 <sup>1</sup> (4.0 in. Insulation)	199.0	0.2927
HI-R-H Half High Jamb Unit 12x4x16 <sup>1</sup> (4.0 in. Insulation)	163.7	0.2408

<sup>1</sup>. All volumes are derived from CBIS/KORFIL Equivalent Thickness Calculations for the specific unit.

# Spec-Thermal® HI-R and HI-R-H Construction Notes

## Building Bond Beams

For Spec-Thermal Hi-R units, check with your local manufacturer for available bond beam units (or full web Hi-R units can be cut for use as a knock out bond beam unit). For HI-R-H units, the standard HI-R-H unit may be used as a bond beam unit without the need for any modifications.

## Anticipate Vertical Rebar Placement

Provide the General Contractor information on the proper spacing and location for vertical rebar placement at grade to take into account the location of the groutable areas of the HI-R or HI-R-H units to avoid the need to bend rods or cut block.

## Joint Reinforcement Placement

The HI-R and HI-R-H Systems work with 9-gauge Ladder Type Wall Reinforcing with butt welded center cross rods at 16 inch increments. The rods should be placed directly over webs of blocks to allow the innermost insert to be pushed down to lock with the insert below it. You will note a slight indent in the top of the inserts at this location to accommodate the joint reinforcement. If you use a standard CMU sash or jamb units at joints or jambs with HI-R or HI-R-H units, it will be necessary to splice the horizontal joint reinforcement at that location (this is highlighted in the details).

## Building Corners

Corners can be constructed using standard masonry fittings and rigid insulation or, where available, by using the HI-R-H Jamb/Sash Unit or HI-R-H Half High Jamb/Sash Unit as shown in the details.

## Load-bearing Points

The details in this manual show construction of load-bearing points under bar joist, precast beams, etc. In the details, the load bearing point is located above the block and grout, and not the inserts. If the building design does require a load bearing point over an insert, the insert at that location should be removed so that grout can be placed there. Consult your project architect and engineer for approval.

## **Spec-Thermal® HI-R and HI-R-H Construction Notes**

### **Store or Dispose of Loose Inserts**

Since the inserts are relatively light and can be moved by wind, collect and secure any loose inserts on the job site.

### **Architectural Masonry Construction Best Practices.**

For general information on building with architectural masonry, please refer to "Spec-Brik® Construction Best Practices" available from the Concrete Products Group LLC.

For more information, contact CPG at 1-800-789-0872 or [info@concreteproducts-group.com](mailto:info@concreteproducts-group.com)



---

# HI-R Construction Details

---

## HI-R®

Spec-Thermal® HI-R® is a proven solution for the construction of energy efficient structures with a track record of several decades of successful performance. The insulation inserts and reduced web profiles provide HI-R® units with significant advantages over conventional masonry, while offering the durability, simplicity and aesthetic appeal of double exposed masonry. Spec-Thermal® HI-R® provides designers with the flexibility to meet demanding energy Codes with proven performance.

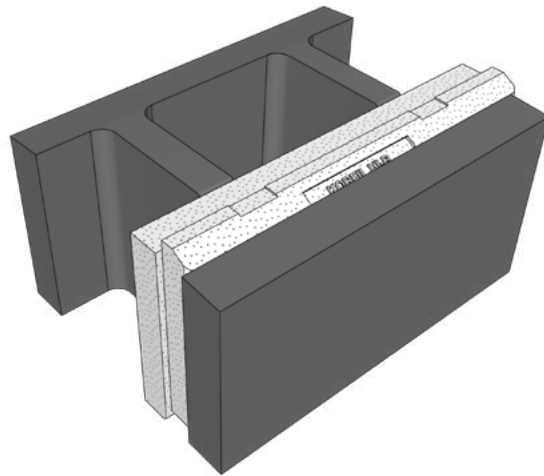

***12×8×16 Spec-Thermal® HI-R® Unit  
with 2.5" EPS Insert***

### **Key Features**

**Energy Efficiency.** The HI-R System offers thermal performance that gives designers the flexibility to meet Code requirements with a masonry wall system that uses integral insulation.

**Construction Efficiency.** The HI-R wall system is an efficient single wythe wall system where the insulation and interior and exterior wall finishes are all constructed in a single construction step. HI-R is an excellent choice for partially grouted walls so that materials usage efficiency is optimized.

**Compatibility and Flexibility.** The HI-R wall system is fully compatible with standard masonry fittings and interfaces seamlessly with other building components giving the designer unlimited detailing flexibility. HI-R block webs are located in different areas to standard CMU. When building a Hi-R wall above or below a standard CMU wall the

webs of HI-R units will be centered at the cores of standard CMU. The wall bond will need to be adjusted to ensure vertical reinforcing remains continuous.

**Moisture Penetration Resistance.** Multiple measures resist moisture penetration. HI-R units and the mortar contain integral water repellent. A Post-Applied clear breathable water repellent is applied to the wall system. The interlocking insulation inserts provide increased resistance to wind driven rain. When partially grouted, drainage is provided in the cores to the flashing and weep systems. When fully grouted, no flashing or weeps are necessary except adjacent to certain openings in the wall and tops of parapets.

**Air Barrier Requirements.** When partially grouted, several Code-based methods, including application of block fillers, or opaque coatings, parges, stucco, plaster, etc. can be employed for this system. When fully grouted, the system is deemed to comply with the International Energy Conservation Code's air barrier requirements.

**Aesthetic Choices.** HI-R units are available in the full range of masonry finishes and colors.



**HI-R Bond Beam, Corner and Control Joint Under Construction**

## Wall System: 12×8×16 and 10×8×16 HI-R

### Summary of System Component Options:

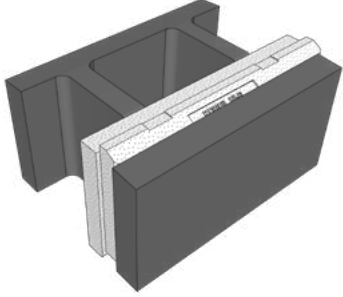
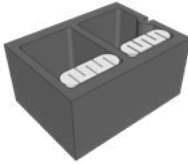
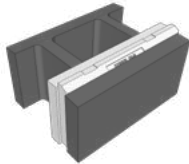
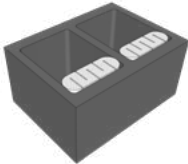
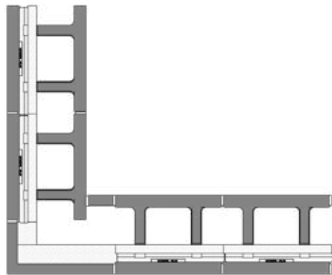
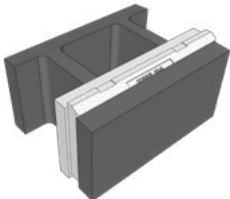
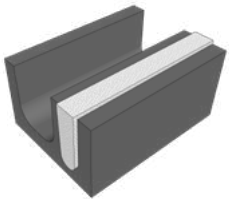
	<p><b>Main wall units:</b>          HI-R 12×8×16 Stretcher Unit          or          HI-R 10×8×16 Stretcher Unit          2.5" insulation insert</p> <p><b>Bond beams:</b>          HI-R 12×8×16 or 10×8×16 Stretcher Unit with          reduced web height</p>			
	<p><b>Movement or Control Joints:</b>          CMU Sash or HI-R Michigan Style Control Joint</p>	 <p>CMU Sash with Icon® Inserts</p>	 <p>HI-R for Michigan Style Control Joint</p>	 <p>CMU Jamb with Icon® Inserts</p>
	<p><b>Jambs:</b>          CMU Jamb</p>			
	<p><b>Corners:</b>          L-Shaped CMU fitting with EPS          Insulation</p>			
	<p><b>Lintels:</b>          HI-R units or          HI-R/HI-R-H Closed Bottom Lintel*</p>	 <p>HI-R Unit</p>	 <p>HI-R/HI-R-H Closed Bottom Lintel</p>	

\* Availability may be limited in some regions. Please confirm local availability before specifying.

Detail 4-2000 - HI-R - CMU Foundation - Slab at Grade

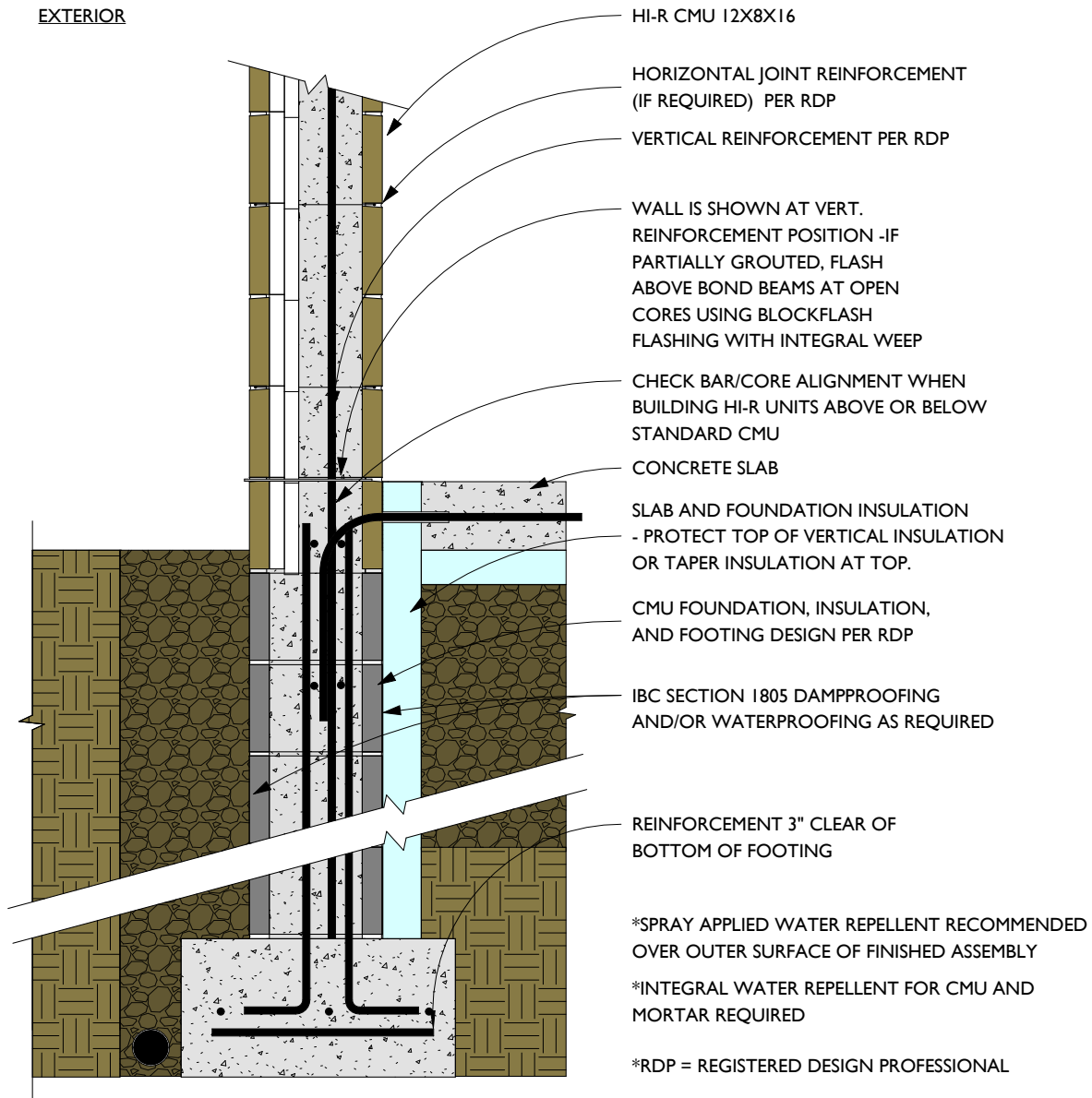

\*THIS DETAIL IS A STANDARD DETAIL. DESIGNERS SHOULD MAKE SITE SPECIFIC INVESTIGATIONS TO DETERMINE ACTUAL DESIGN REQUIREMENTS.

Detail 4-2001 - HI-R - Foundation - Concrete

EXTERIOR

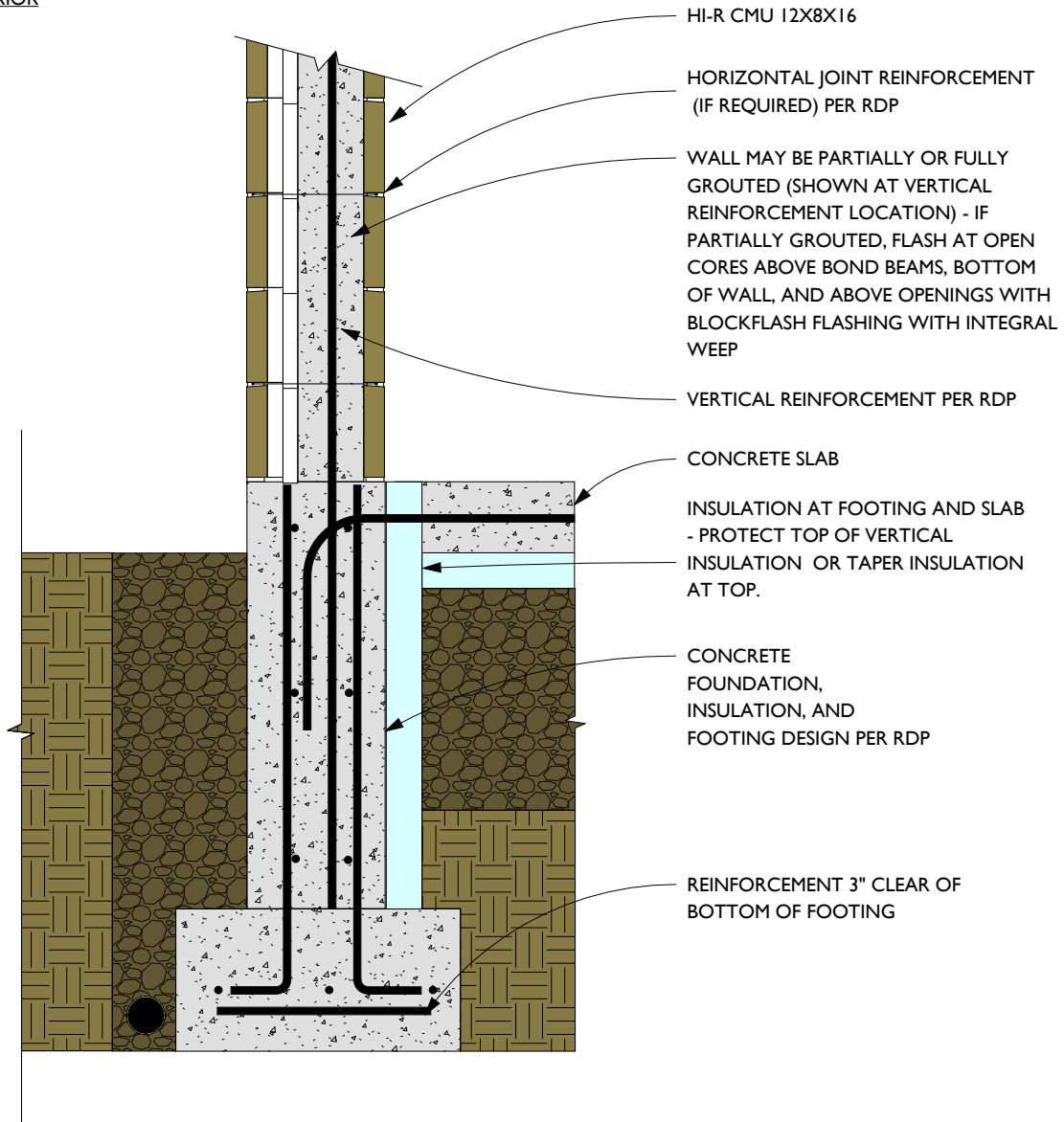

\*THIS DETAIL IS A STANDARD DETAIL. DESIGNERS SHOULD MAKE SITE SPECIFIC INVESTIGATIONS TO DETERMINE ACTUAL DESIGN REQUIREMENTS.

Detail 4-2002 - HI-R - Foundation - Fully Grouted HI-R Stem Wall

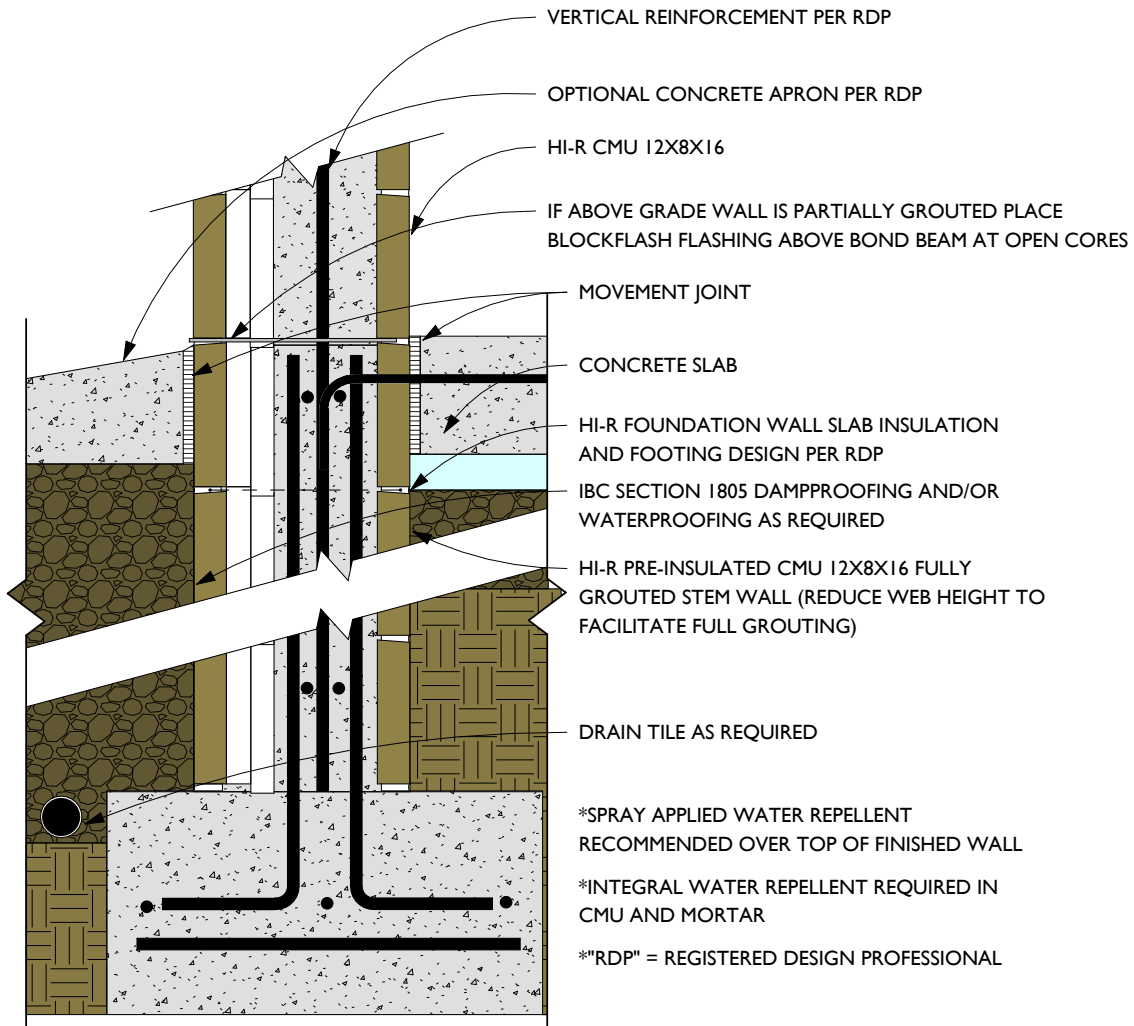

\*THIS DETAIL IS A STANDARD DETAIL. DESIGNERS SHOULD MAKE SITE SPECIFIC INVESTIGATIONS TO DETERMINE ACTUAL DESIGN REQUIREMENTS.

## Foundations – Additional Notes

1. In this manual, we present three choices for foundation wall construction: poured in place concrete, CMU, and pre-insulated CMU – Spec-Thermal® HI-R or HI-R-H. Each will meet structural requirements when properly designed. Both the concrete and traditional CMU footing/stem/crawl space/foundations will typically require insulation placement either to the exterior or interior (or both) of the foundation wall. The Spec-Thermal foundation walls are pre-insulated with integral insulation in the unit. Consult with Structural and/or Geo-technical Engineers for appropriate below-grade insulation material and placement.
2. Check local Code for slab insulation requirements – if the slab is on grade, address the thermal bridge at the slab by either placing interior or exterior insulation at this location. Insulation placed at the exterior will typically require some form of hardened protective covering. For insulation requirements see e.g., IECC/IRC Section R402.2.10/N1102.2.10 Slab-On-Grade Floors.
3. The use of pre-insulated block for the foundation and above grade walls provides a simple way to meet insulation requirements for both types of walls. Use of Hi-R CMU at the foundation ensures web alignment with Hi-R units above grade. It also has structural benefits as the foundation wall is fully supported directly by the engineered soils. Full grout should be used for the foundation wall. The insulation is protected integral insulation which eliminates insulation damage concerns.
4. Generally a damp-check needs be placed above the top of the damp-proofing or waterproofing for foundation walls, basement walls, or foundations. For below-grade masonry basement walls an additional damp check at the masonry starting course and above the damp-proofing or waterproofing for slabs and floors will further control moisture. An above-grade masonry course with flashing also performs as a damp-check.
5. A tapered (30° from horizontal) 6" zone of free-draining gravel extending from the height of the finished floor to the top of the engineered soil may be substituted for the concrete apron shown.
6. HI-R single wythe walls may be partially grouted or fully grouted. If partial grout is used, flashing and weeps should be placed at all interruptions in the drainage plane in the wall – typically these will occur at bond beams, lintels and the bottom of the wall.
7. There are a variety of time-proven methods to provide flashing. For single wythe walls, we suggest the use of the pan flashing system Blockflash® over traditional through wall flashing methods because it can be placed without interrupting the mortar bond in the bed joint between the units where it is placed.
8. To provide robust protection of single wythe walls from moisture penetration, we recommend integral water repellent (IWR) be used in both the block and mortar. The IWR in the block and mortar need to be chemically compatible (check with block manufacturer for recommendations). Some exceptions to using IWR may apply such as for California masonry core testing. To provide additional protection, we recommend use of a post-applied breathable water repellent over the finished wall after cleaning is completed and approved and the walls are completely dry.
9. If the zone near the above-grade wall or foundation wall is to be landscaped, do not place plant life, roots, irrigation, fertilizers or other chemicals within 3 feet of the above-grade wall or foundation wall. Isolate the above-grade wall, foundation wall, footing, foundation, and slab from such elements.
10. All details are available in Revit® and AutoCAD® – the numbering of the details in this manual corresponds to that used in the Revit® and AutoCAD® files.

Detail 4-2100 - HI-R - Michigan Style Control Joint Bond Beam - Section View

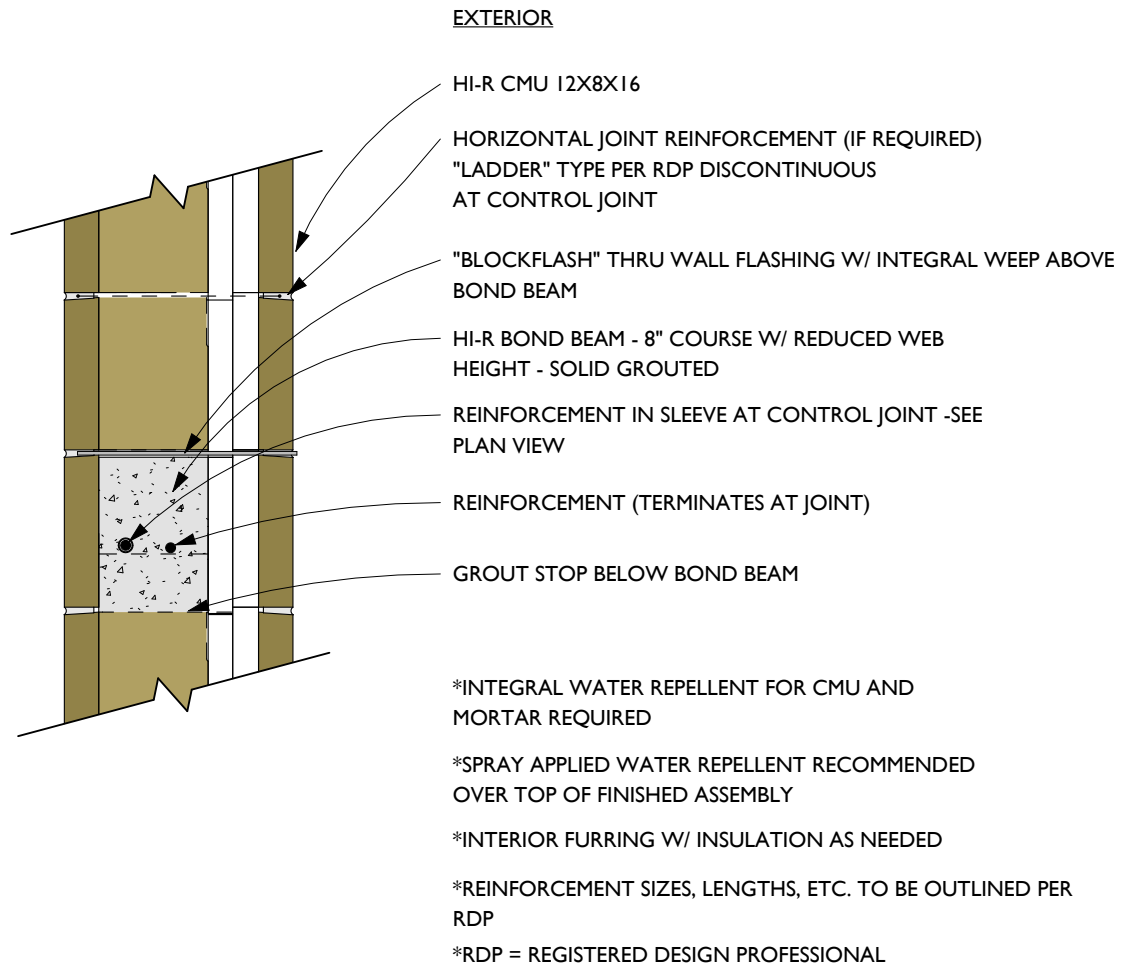

\*THIS DETAIL IS A STANDARD DETAIL. DESIGNERS SHOULD MAKE SITE SPECIFIC INVESTIGATIONS TO DETERMINE ACTUAL DESIGN REQUIREMENTS.

## Control Joints

### Detail 4-2101 - HI-R - Michigan Style Control Joint - Plan View

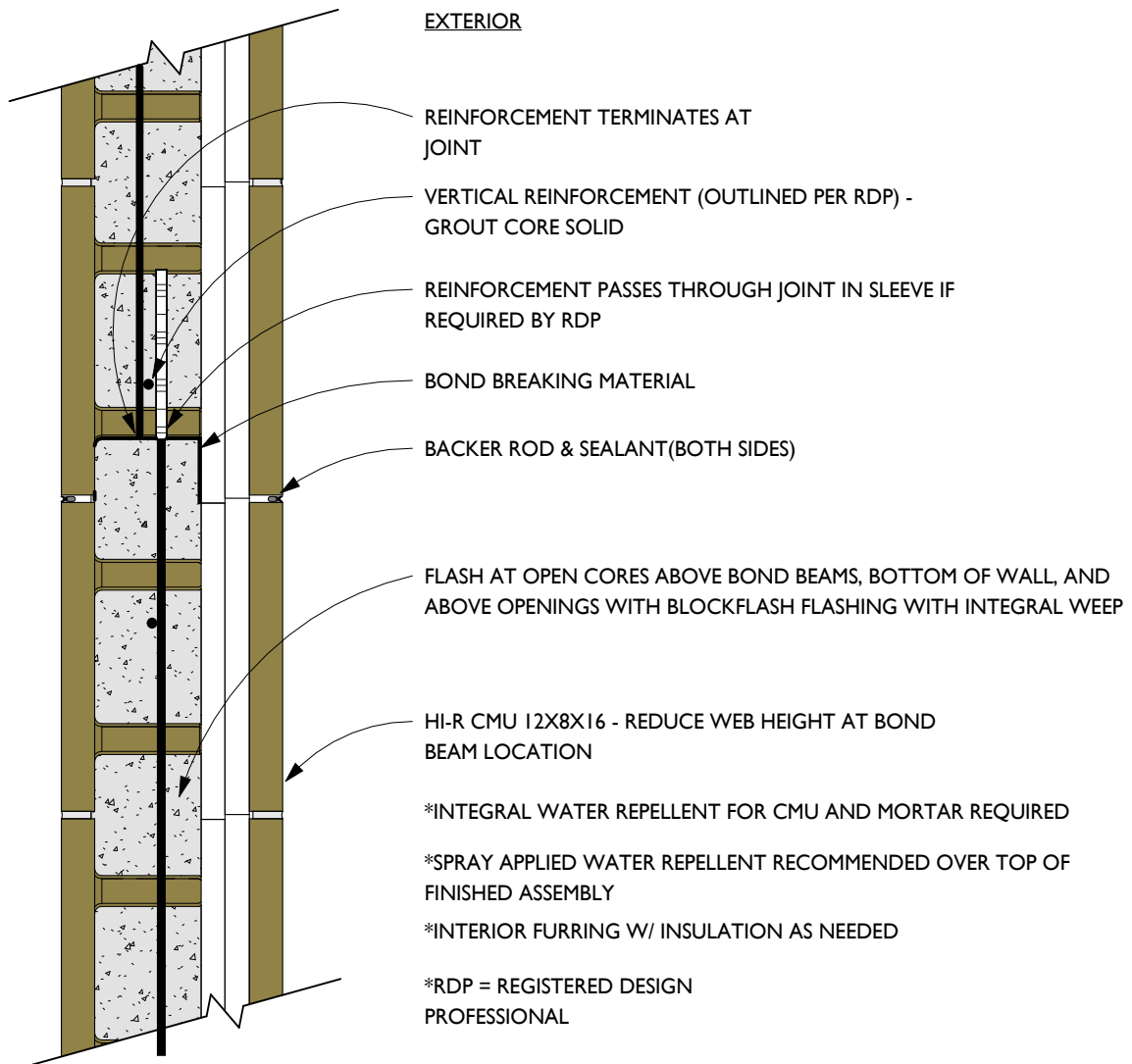

\*THIS DETAIL IS A STANDARD DETAIL. DESIGNERS SHOULD MAKE SITE SPECIFIC INVESTIGATIONS TO DETERMINE ACTUAL DESIGN REQUIREMENTS.

## Control Joint

### Detail 4-2102 - HI-R - Control Joint with Gasket and Sash Unit

EXTERIOR

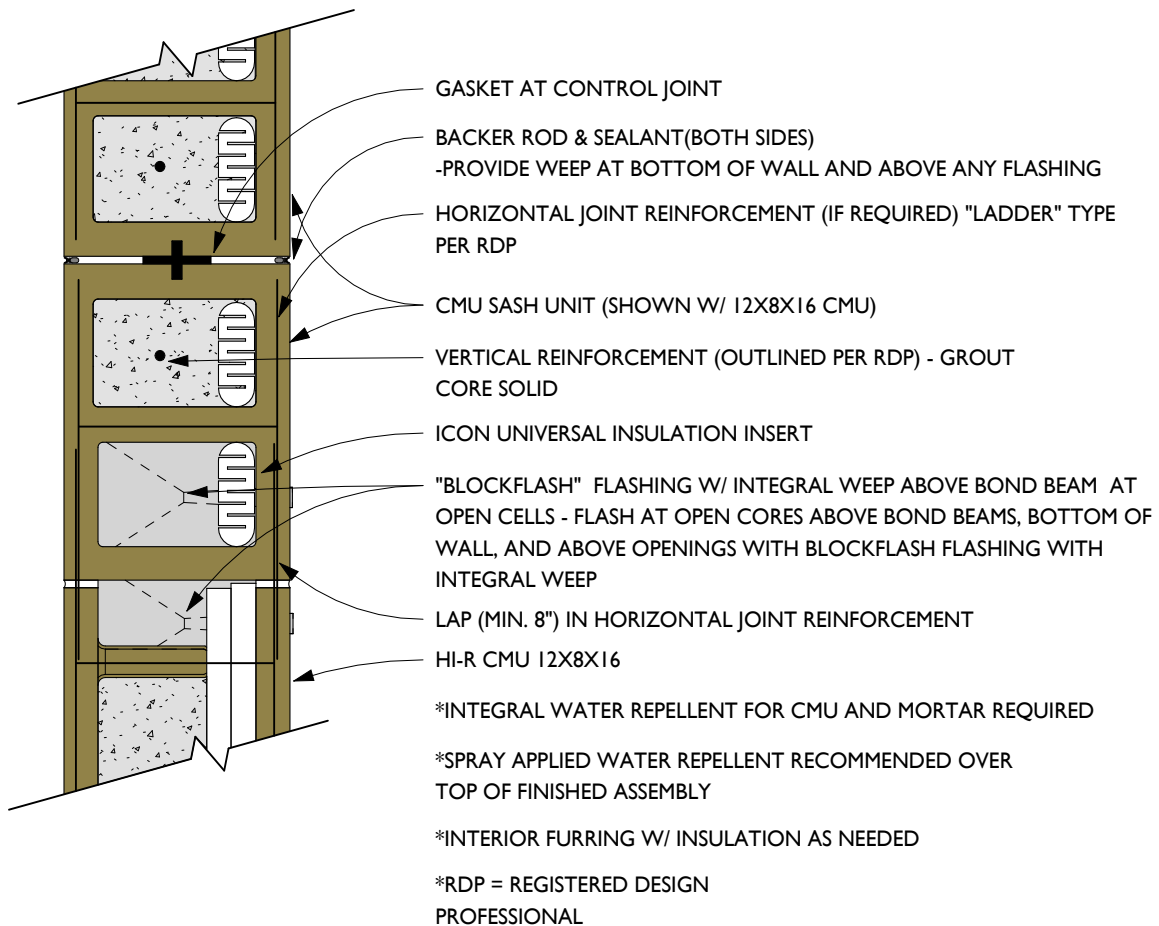

\*THIS DETAIL IS A STANDARD DETAIL. DESIGNERS SHOULD MAKE SITE SPECIFIC INVESTIGATIONS TO DETERMINE ACTUAL DESIGN REQUIREMENTS.

## Bond Beam

### Detail 4-2103 - HI-R - Bond Beam

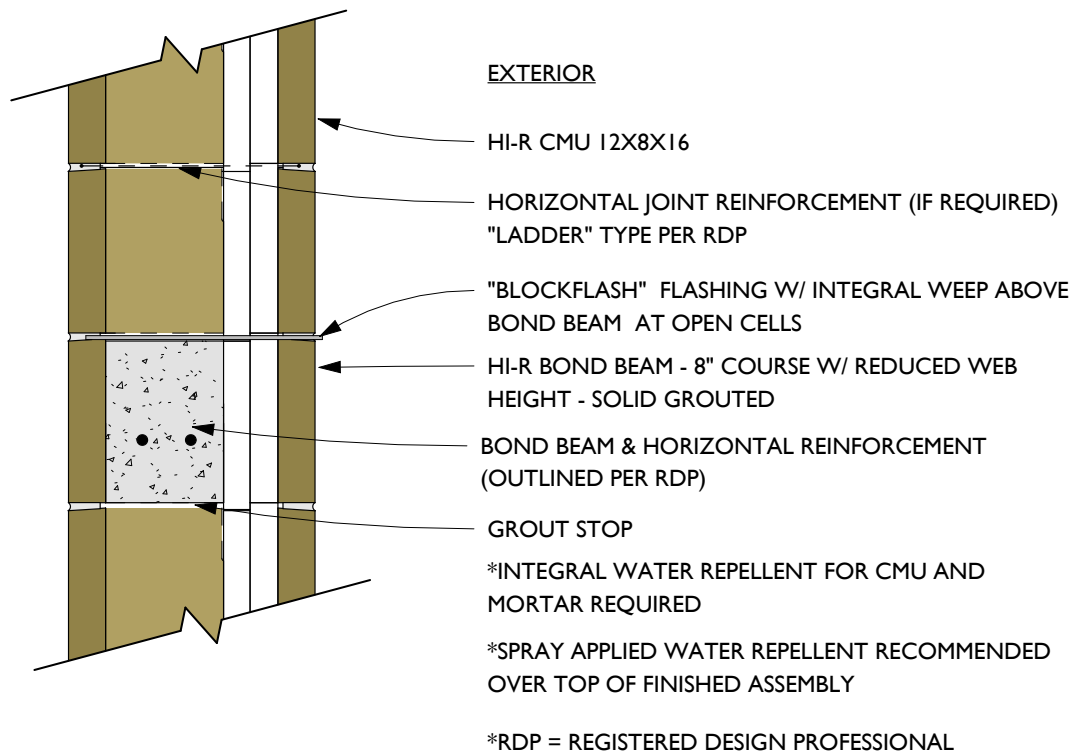

\*THIS DETAIL IS A STANDARD DETAIL. DESIGNERS SHOULD MAKE SITE SPECIFIC INVESTIGATIONS TO DETERMINE ACTUAL DESIGN REQUIREMENTS.

## Horizontal Joint Reinforcement

### Detail 4-2104 - HI-R - Horizontal Joint Reinforcement

EXTERIOR

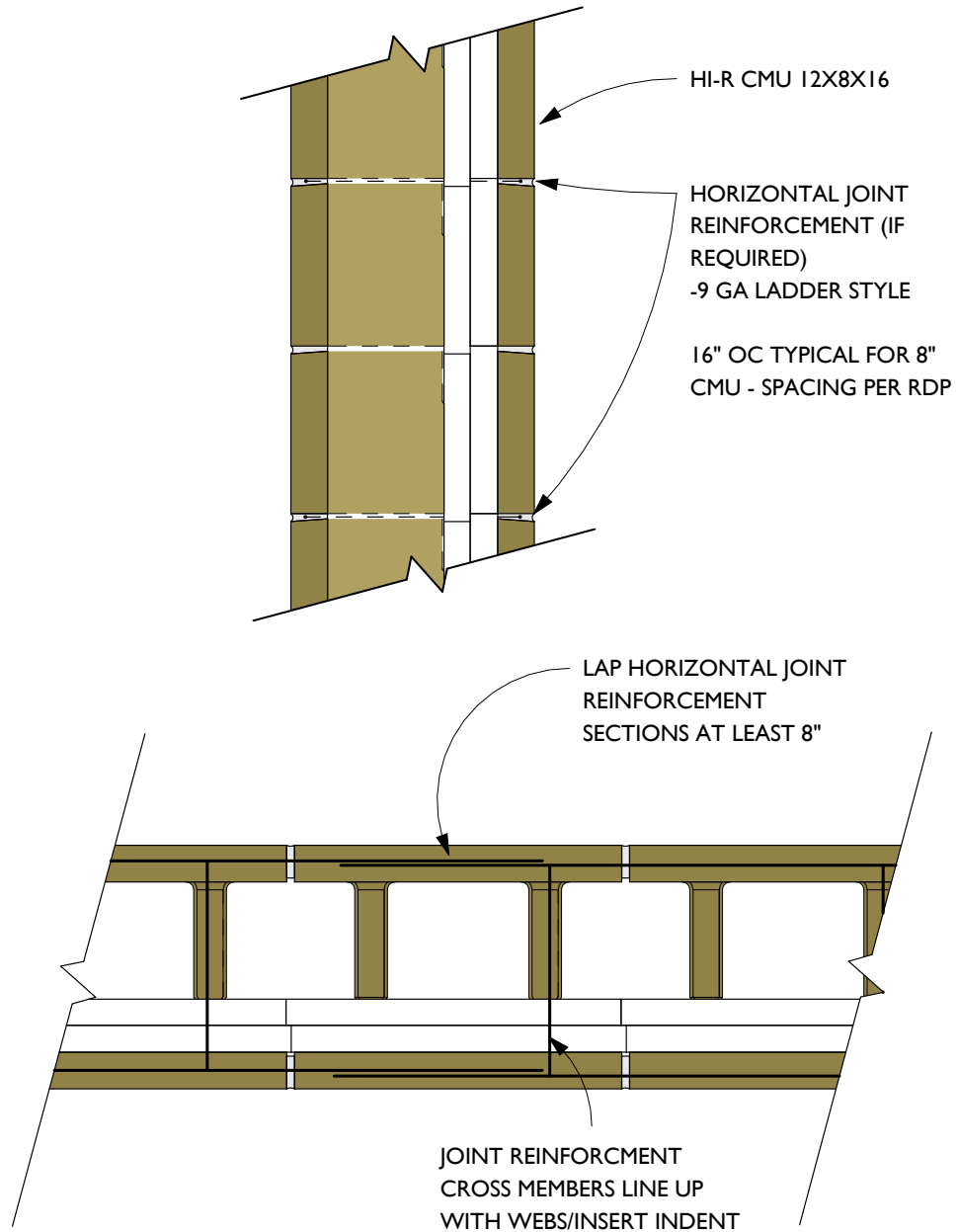

\*THIS DETAIL IS A STANDARD DETAIL. DESIGNERS SHOULD MAKE SITE SPECIFIC INVESTIGATIONS TO DETERMINE ACTUAL DESIGN REQUIREMENTS.

## Additional Notes – Bond Beams, Control Joints and Horizontal Joint Reinforcement:

1. Bond beams are typically built using HI-R unit with reduced web heights. This is typically done by saw cutting the web to make the unit a knock out bond beam unit.
2. The Michigan style control joint allows the joint to have the same thermal properties as the main stretcher units. It is a more labor intensive choice compared to using the joint with a pre-formed gasket and sash unit. The trade-off is greater thermal performance vs. construction efficiency.
3. The HI-R system is designed to accommodate 9 ga. ladder type horizontal joint reinforcement. The insulation inserts have a slight indentation that aligns with the unit webs. HJR should be placed with the cross rods located at these indentations and block webs. 16" spacing of the cross rods is typical.
4. Control joints are a method to assist in controlling cracking in concrete masonry walls by allowing discrete panels in the field of a larger wall to accommodate shrinkage. There are a variety of methods to construct a control joint.
5. There are a variety of construction joints with differing names and purposes (and consistency of usage has been an issue). The joints shown in this manual are used with these meanings:
  - **Control Joint** – A joint used to break up a large field of concrete masonry into discrete panels for the purpose of allowing shrinkage and mitigating cracking.
  - **Movement Joint** – A generic term for a joint that may be intended to serve in multiple functions or accommodate multiple sources of movement.
  - **Relief Joint** – A weakened section of reinforced concrete masonry used to control and isolate the formation of shrinkage related cracks.
6. Though not depicted here, another important use for joints is in areas where there are interfaces between materials that may have different movement properties. One example would be placing a section of clay brick (tends to expand over time) above or below a section of concrete masonry (tends to shrink over time) in a wall. Placing a joint between the differing materials will accommodate any slight differential in expansion/contraction properties.
7. In general, the specific spacing and placement of control joints for a project should be reviewed by the project structural engineer who can design the joint spacing in the most efficient manner. Refer to the CMHA (formerly NCMA) TEK notes for required horizontal reinforcement for crack control based on upon joint sizes and locations selected by RDP. Horizontal reinforcement can be provided by either use of horizontal joint reinforcement or horizontal reinforcing rebar.
8. For best results, **remember masonry modularity when placing joints (also true for designing the length and height for walls and the size and placement of openings)** This means these locations should be in multiples of 8 inches from the end of the wall. Designing with modularity in mind will result in optimal efficiency when the wall is built, because if the dimensions are not consistent with masonry modularity then the mason contractor will have to cut units in the field to fit the design.

Corners

Detail 4-2120 - HI-R - Corner - 12X8X16 - CMU Fitting Course 1

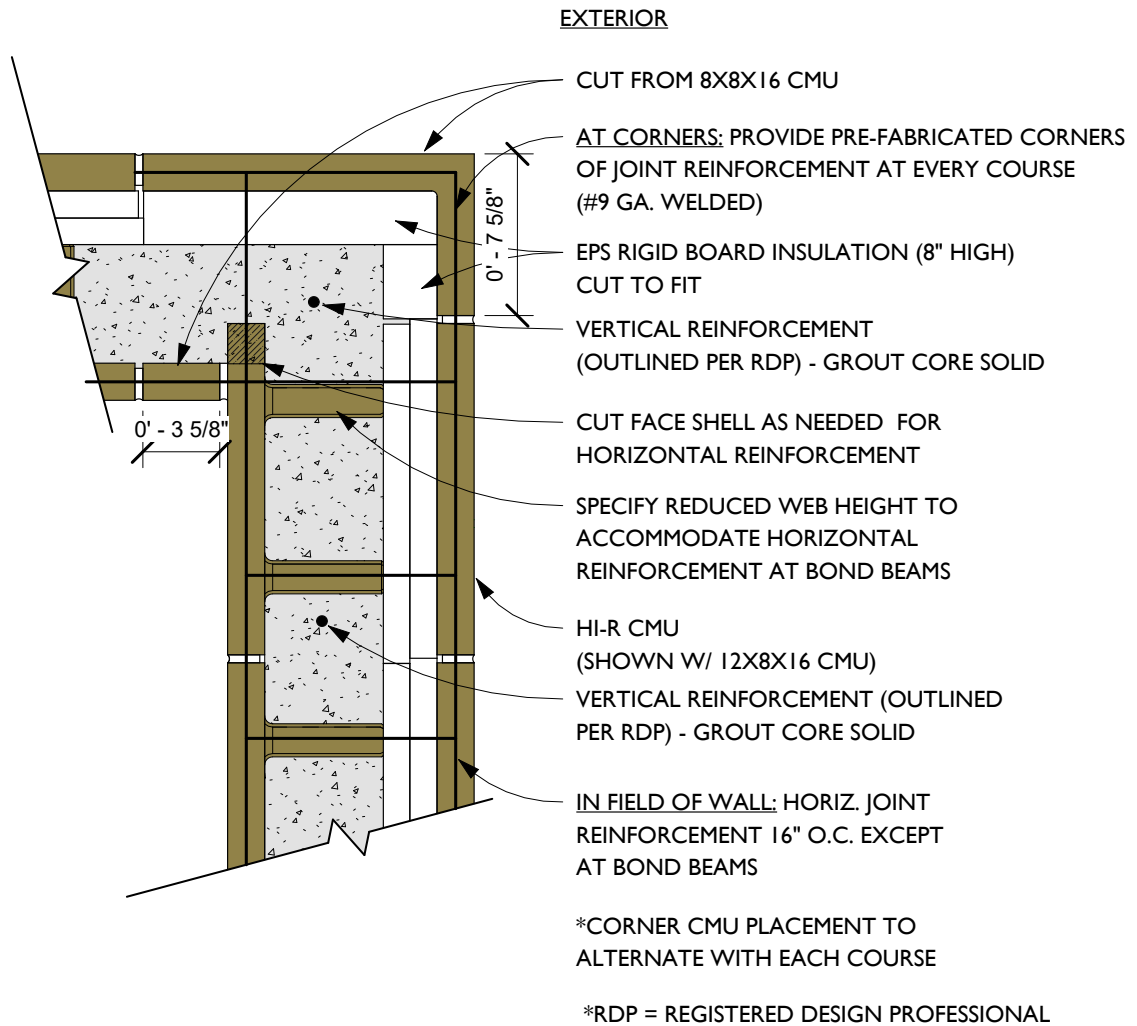

\*THIS DETAIL IS A STANDARD DETAIL. DESIGNERS SHOULD MAKE SITE SPECIFIC INVESTIGATIONS TO DETERMINE ACTUAL DESIGN REQUIREMENTS.

Corners

Detail 4-2121 - HI-R - Corner - 12X8X16 - CMU Fitting Course 2

EXTERIOR

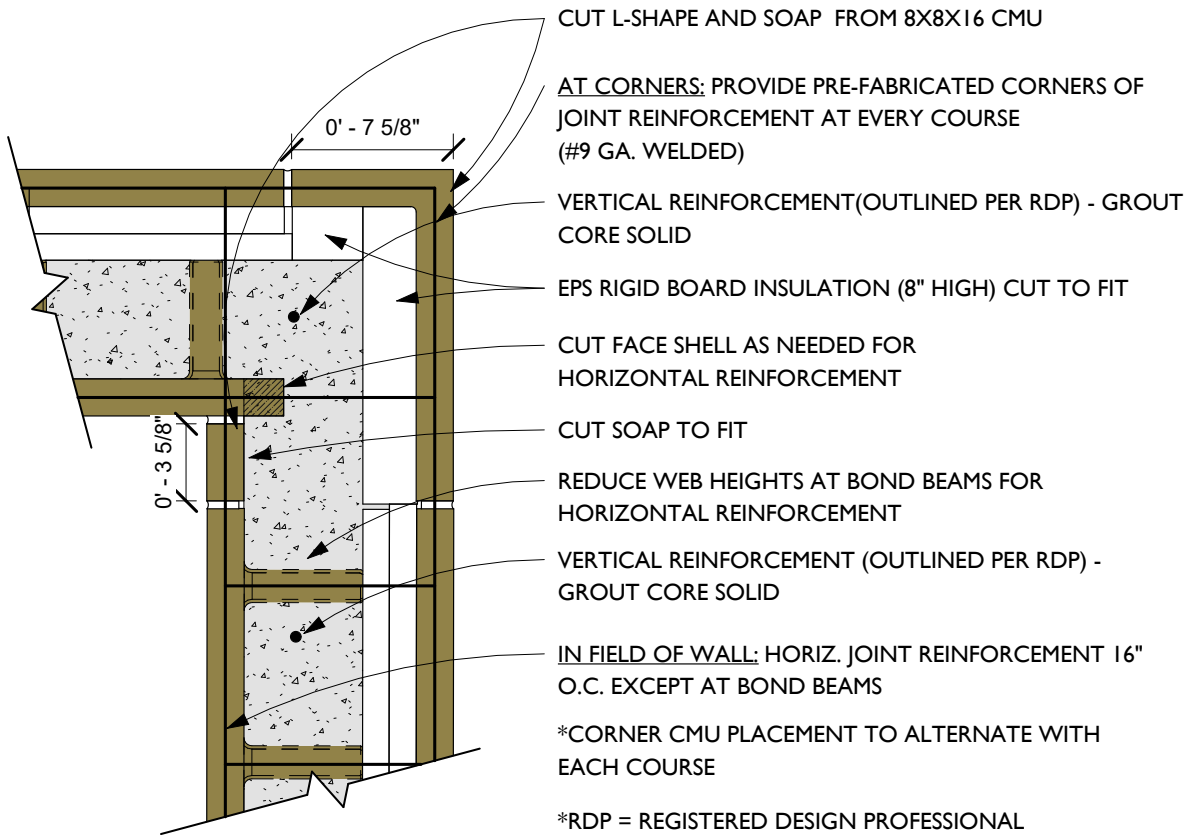

\*THIS DETAIL IS A STANDARD DETAIL. DESIGNERS SHOULD MAKE SITE SPECIFIC INVESTIGATIONS TO DETERMINE ACTUAL DESIGN REQUIREMENTS.

Corners

Detail 4-2122 - HI-R - Corner - 10X8X16 - CMU Fitting Course 1

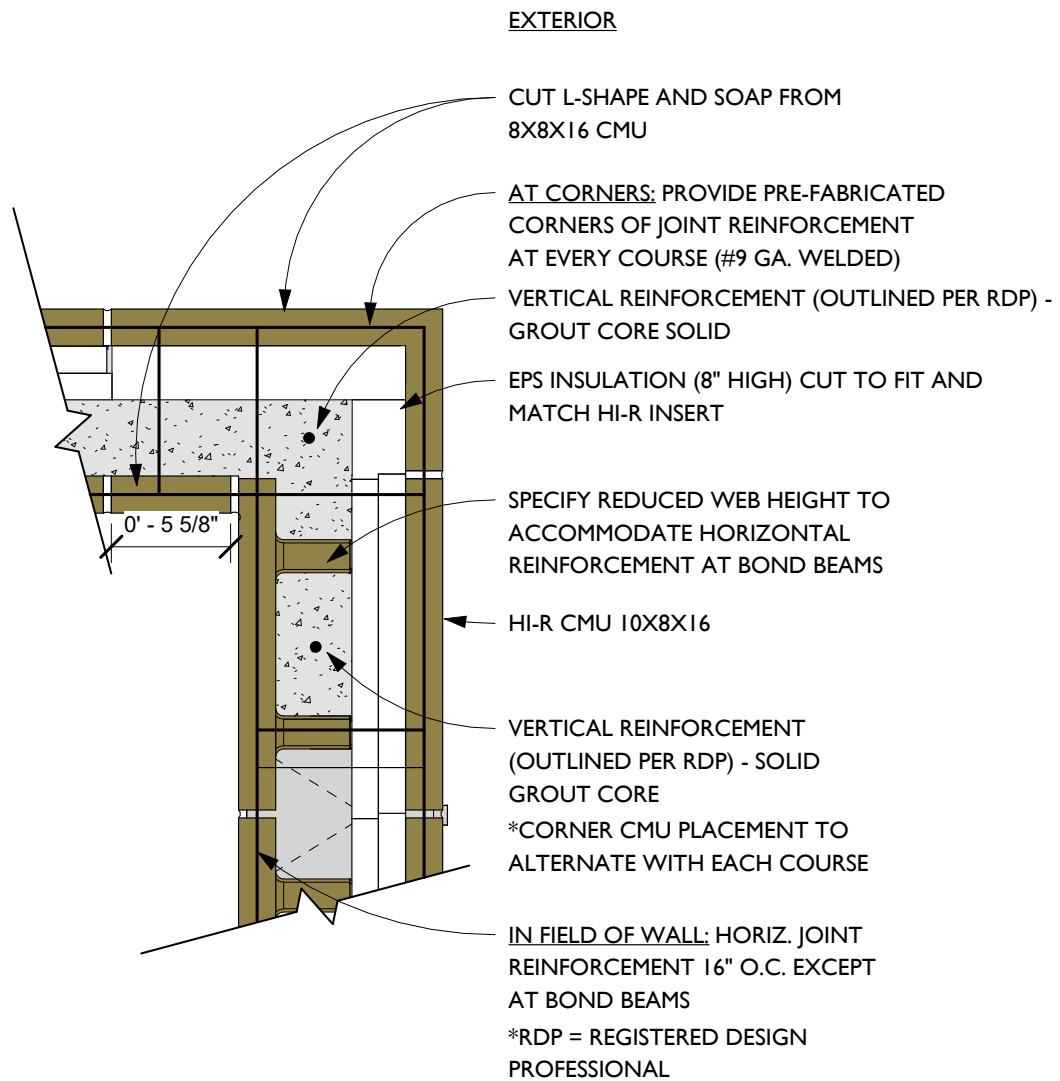

\*THIS DETAIL IS A STANDARD DETAIL. DESIGNERS SHOULD MAKE SITE SPECIFIC INVESTIGATIONS TO DETERMINE ACTUAL DESIGN REQUIREMENTS.

## Corners

### Detail 4-2123 - HI-R - Corner - 10X8X16 - CMU Fitting Course 2

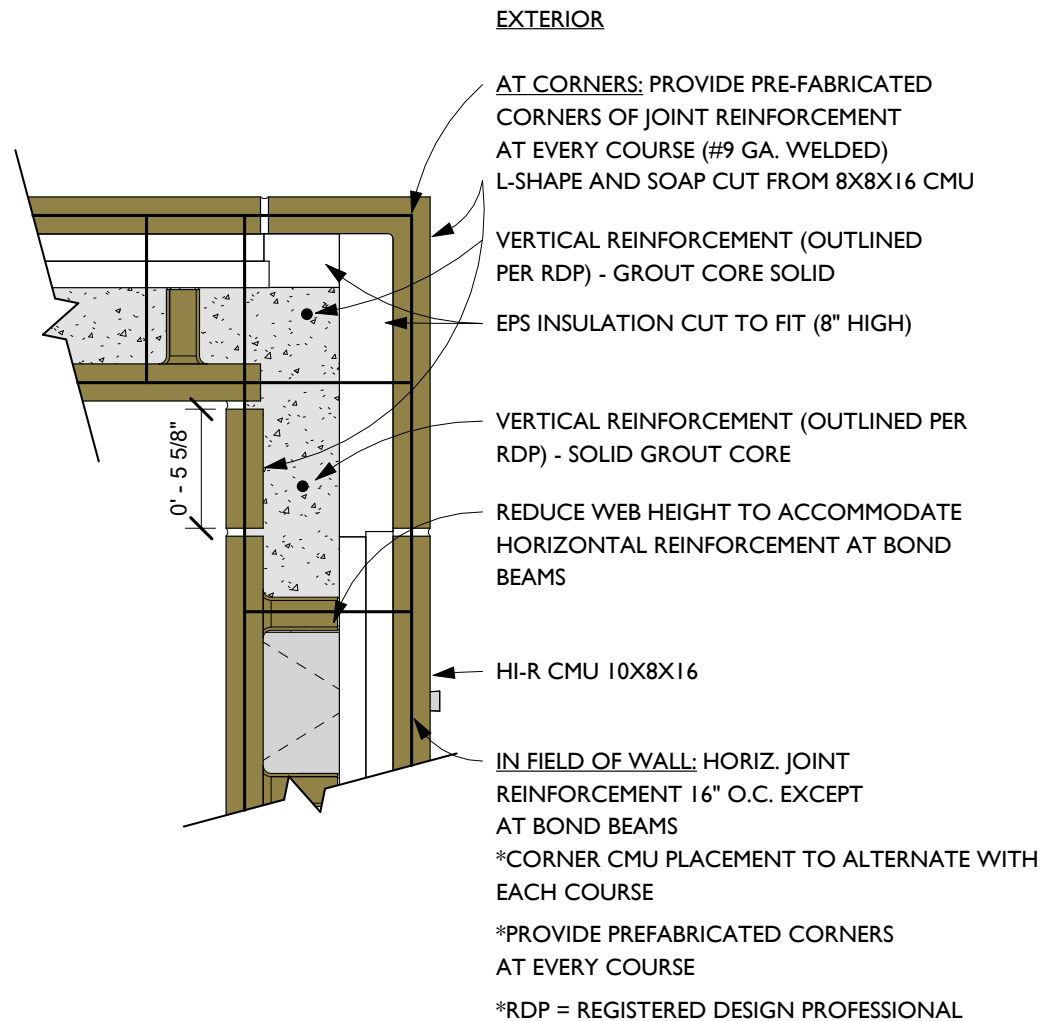

\*THIS DETAIL IS A STANDARD DETAIL. DESIGNERS SHOULD MAKE SITE SPECIFIC INVESTIGATIONS TO DETERMINE ACTUAL DESIGN REQUIREMENTS.

**Additional Notes – Corners:**

1. The use of an L-Shaped fitting and a soap cut from an 8X8X16W unit has proven to be a popular choice for building corners. Another method uses a 8×8×16 corner unit with Icon® insulation but this style of corner has reduced thermal performance compared to the method in these details.
2. Corners should be fully bonded and control joints placed no less than 2' 0" from corner. Grout HI-R corners solid if control joint is less than 4' 0" away from corner.
3. The EPS corner pieces should be at least as thick as the HI-R insulation inserts to provide insulation as good or better than the HI-R units.
4. All details are available in Revit® and AutoCAD® – the numbering of the details in this manual corresponds to that used in the Revit® and AutoCAD® files.



**Corner Detail showing EPS pieces and L-Shaped Corner Fitting**

Detail 4-2200- HI-R - Window Head and Lintel

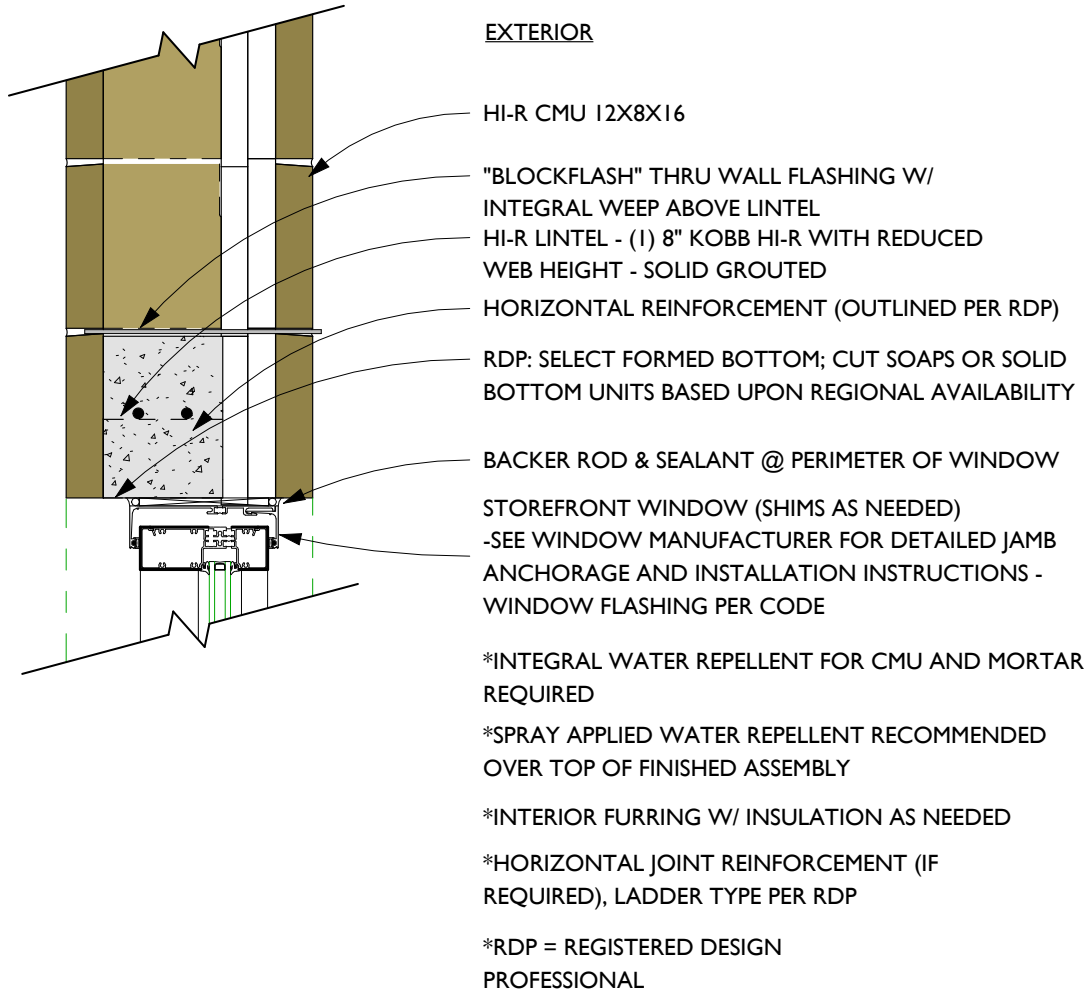

\*THIS DETAIL IS A STANDARD DETAIL. DESIGNERS SHOULD MAKE SITE SPECIFIC INVESTIGATIONS TO DETERMINE ACTUAL DESIGN REQUIREMENTS.

## Window Openings - Window Head and Lintel

### Detail 4-2201- HI-R - Window Head and Lintel with HI-R/HI-R-H Closed Bottom Lintel Unit

PLEASE CONFIRM  
LOCAL AVAILABILITY  
OF HI-R/HI-R-H CLOSED BOTTOM LINTEL  
PRIOR TO SPECIFYING

EXTERIOR

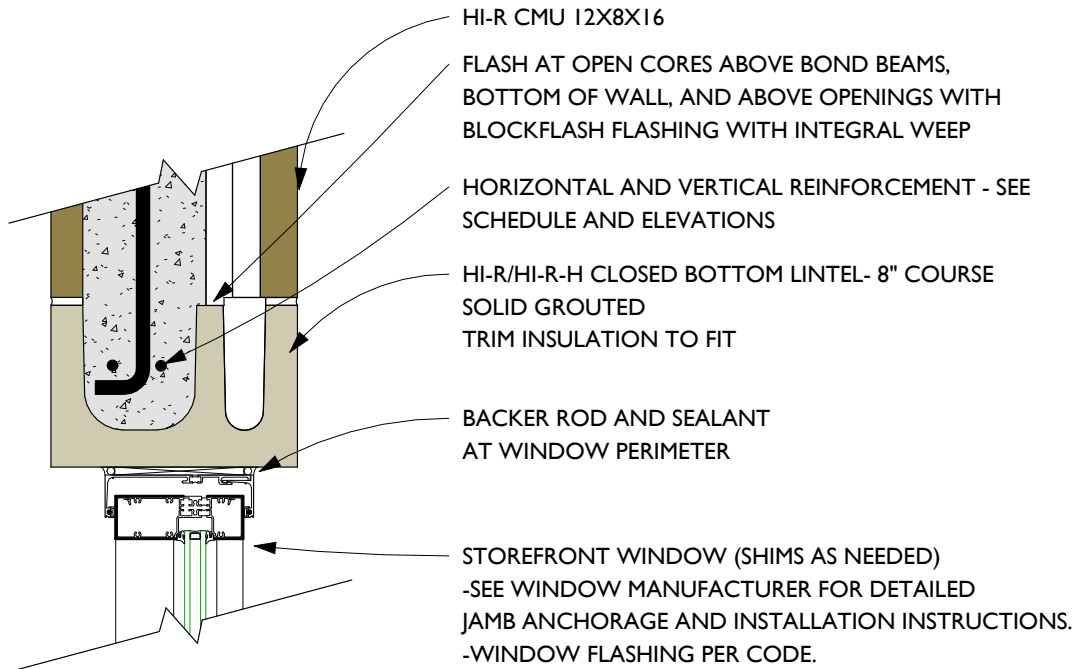

\*THIS DETAIL IS A STANDARD DETAIL. DESIGNERS SHOULD MAKE SITE SPECIFIC INVESTIGATIONS TO DETERMINE ACTUAL DESIGN REQUIREMENTS.

Detail 4-2202- HI-R - Window Jamb with CMU Jamb and Icon® Inserts

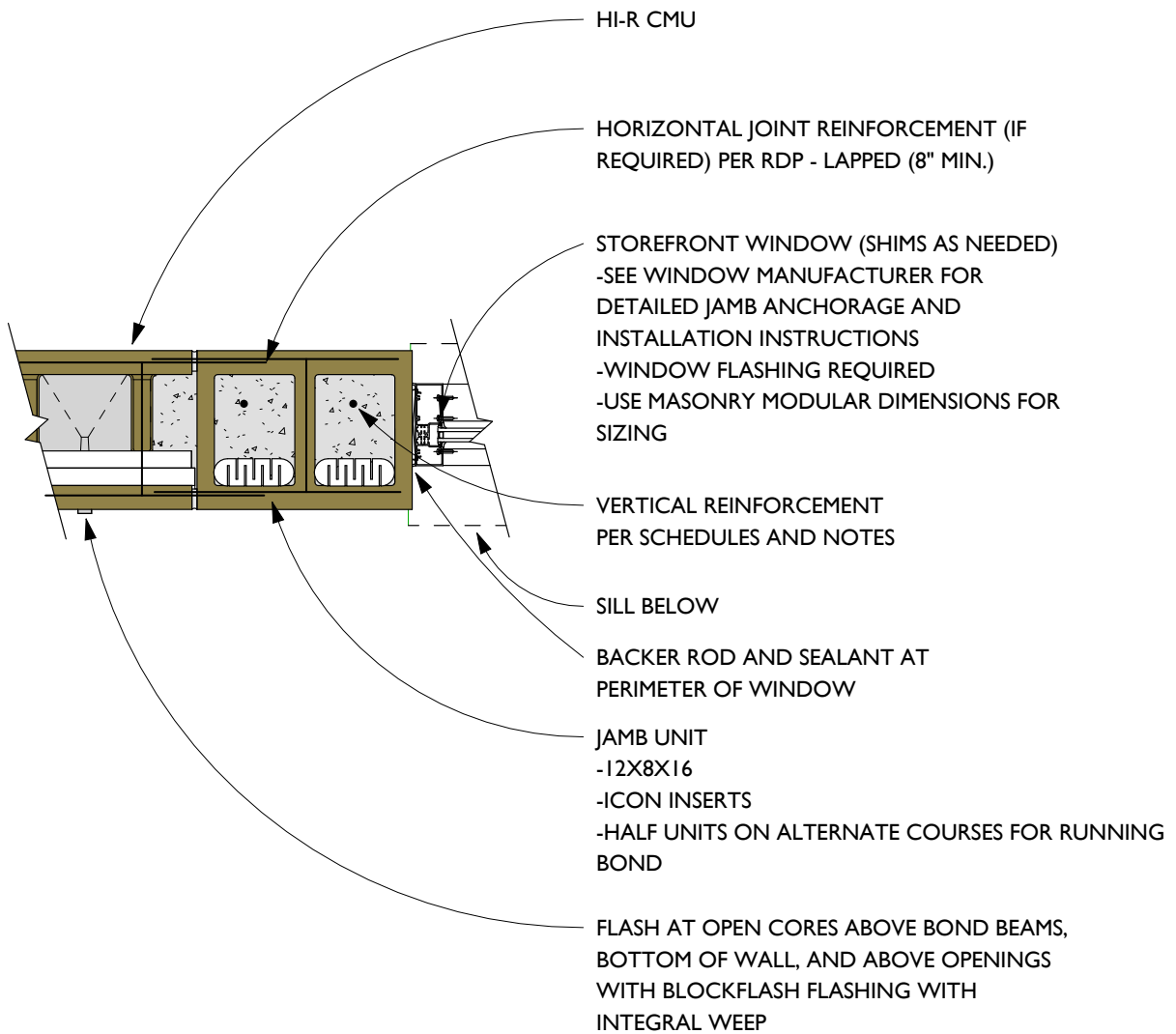

\*THIS DETAIL IS A STANDARD DETAIL. DESIGNERS SHOULD MAKE SITE SPECIFIC INVESTIGATIONS TO DETERMINE ACTUAL DESIGN REQUIREMENTS.

## Window Openings - Window Jamb

### Detail 4-2203- HI-R - Window Jamb with 12x8x8 CMU Jamb and Icon® Inserts

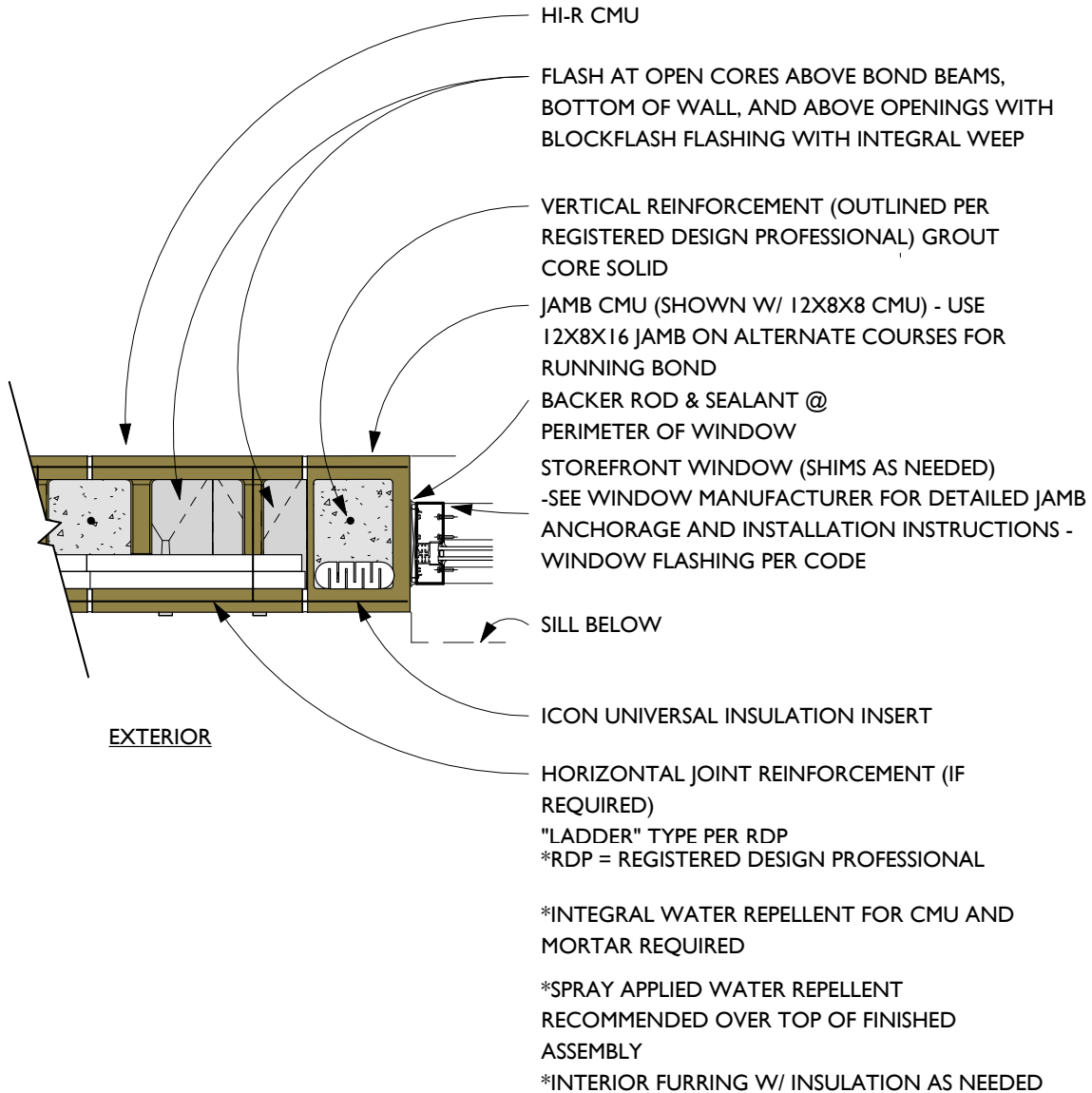

\*THIS DETAIL IS A STANDARD DETAIL. DESIGNERS SHOULD MAKE SITE SPECIFIC INVESTIGATIONS TO DETERMINE ACTUAL DESIGN REQUIREMENTS.

Detail 4-2205- HI-R – Window Sill (4")

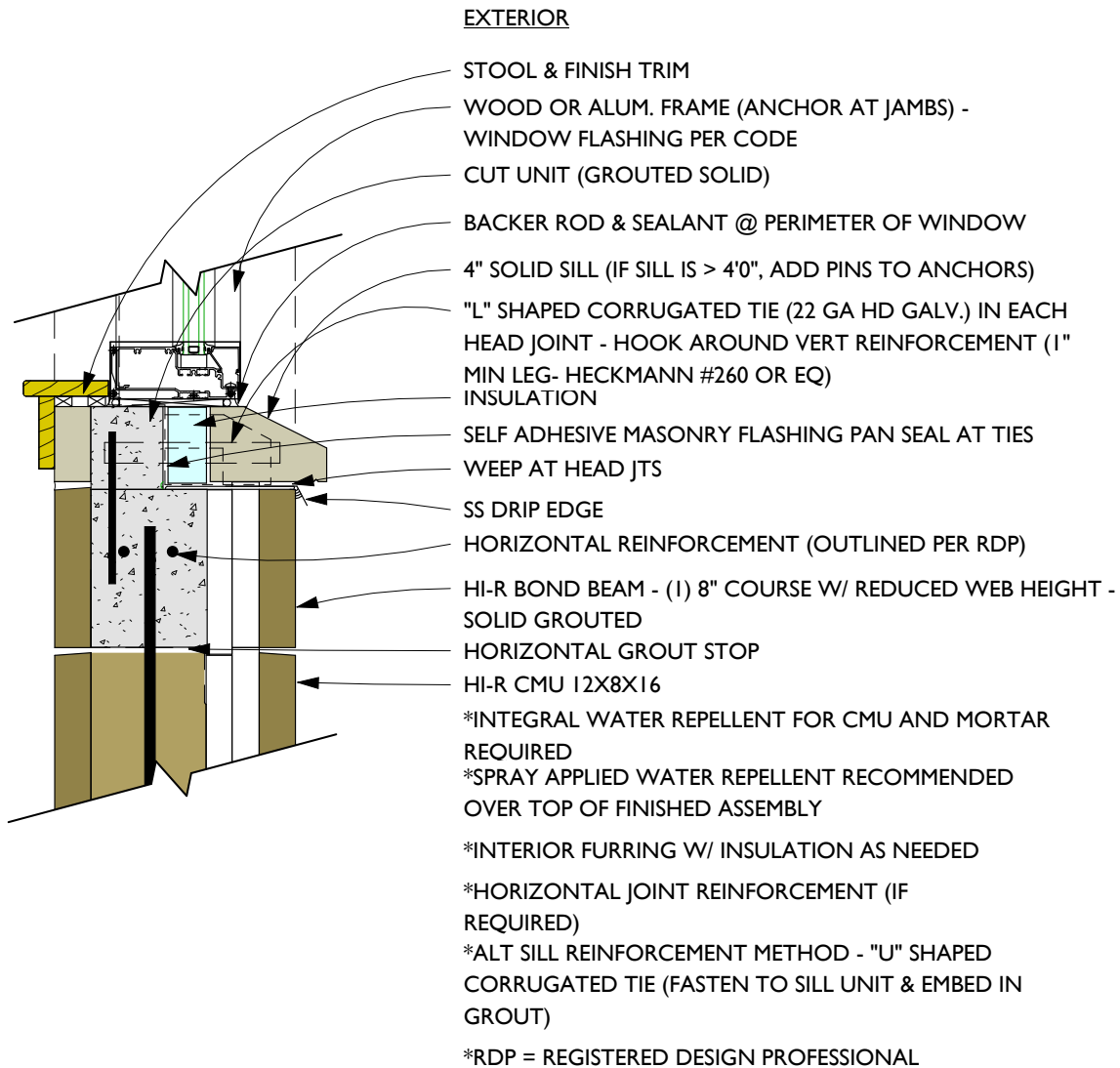

\*THIS DETAIL IS A STANDARD DETAIL. DESIGNERS SHOULD MAKE SITE SPECIFIC INVESTIGATIONS TO DETERMINE ACTUAL DESIGN REQUIREMENTS.

## Window Openings – Sill

### Detail 4-2206- HI-R – Window Sill (8")

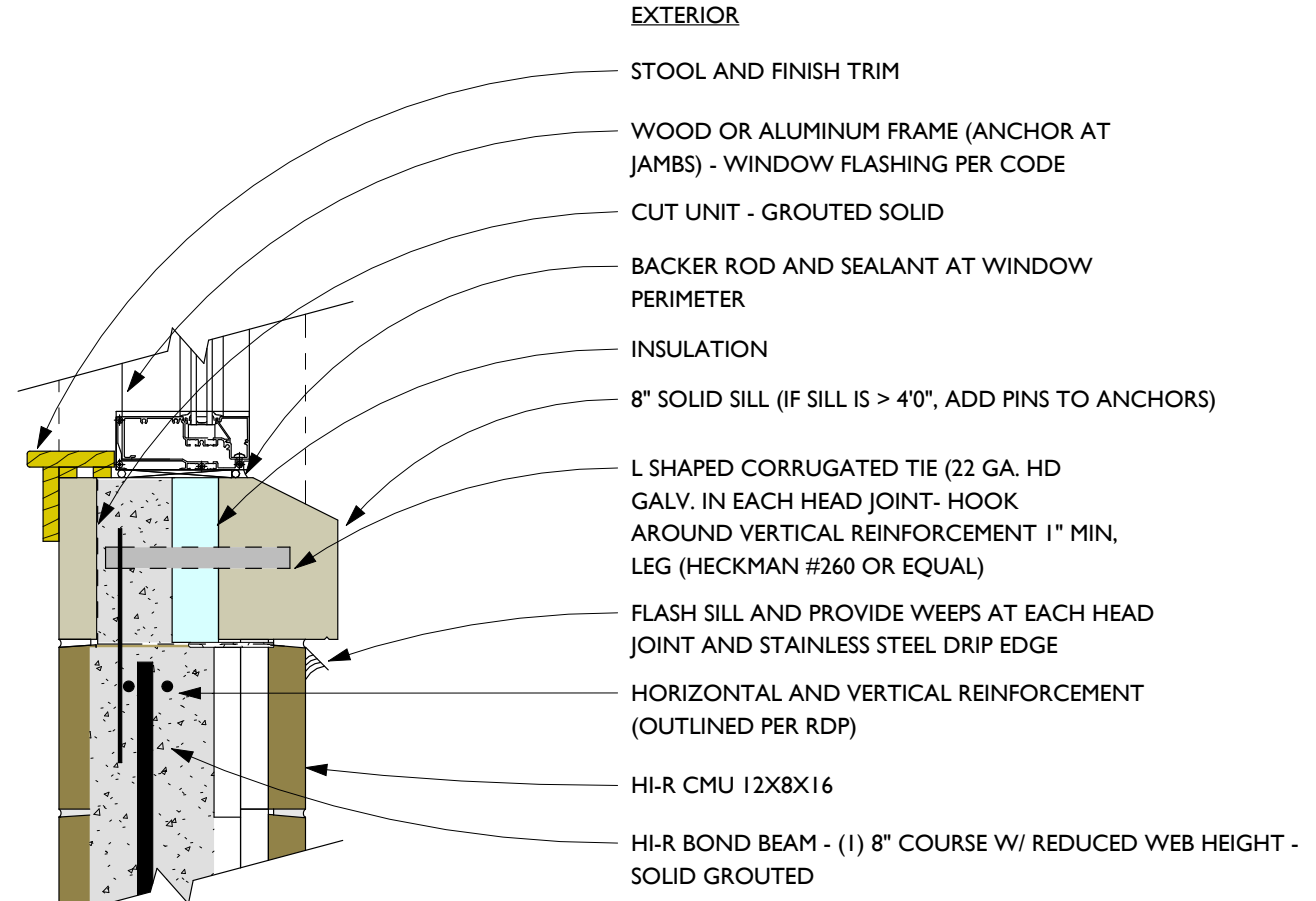

#### EXTERIOR

- STOOL AND FINISH TRIM
- WOOD OR ALUMINUM FRAME (ANCHOR AT JAMBS) - WINDOW FLASHING PER CODE
- CUT UNIT - GROUTED SOLID
- BACKER ROD AND SEALANT AT WINDOW PERIMETER
- INSULATION
- 8" SOLID SILL (IF SILL IS > 4'0", ADD PINS TO ANCHORS)
- L SHAPED CORRUGATED TIE (22 GA. HD GALV. IN EACH HEAD JOINT- HOOK AROUND VERTICAL REINFORCEMENT 1" MIN, LEG (HECKMAN #260 OR EQUAL)
- FLASH SILL AND PROVIDE WEEPS AT EACH HEAD JOINT AND STAINLESS STEEL DRIP EDGE
- HORIZONTAL AND VERTICAL REINFORCEMENT (OUTLINED PER RDP)
- HI-R CMU 12X8X16
- HI-R BOND BEAM - (1) 8" COURSE W/ REDUCED WEB HEIGHT - SOLID GROUTED

\*INTEGRAL WATER REPELLENT FOR CMU AND MORTAR REQUIRED

\*SPRAY APPLIED WATER REPELLENT RECOMMENDED OVER TOP OF FINISHED ASSEMBLY

\*HORIZONTAL JOINT REINFORCEMENT (IF REQUIRED)

"LADDER" TYPE PER RDP

\*ALT SILL REINFORCEMENT METHOD - "U" SHAPED CORRUGATED TIE (FASTEN TO SILL UNIT & EMBED IN GROUT)

\*RDP = REGISTERED DESIGN PROFESSIONAL

\*THIS DETAIL IS A STANDARD DETAIL. DESIGNERS SHOULD MAKE SITE SPECIFIC INVESTIGATIONS TO DETERMINE ACTUAL DESIGN REQUIREMENTS.

### Additional Notes – Window openings:

1. Lintels may either be formed from HI-R units with reduced webs (see notes regarding bond beams) or by using a specialized insulated HI-R/HI-R-H closed bottom lintel unit. This unit is only available in certain regions, so please check first before specifying. Lintels formed from HI-R units will require a surface treatment such as parging or finish trim since the lintel is open bottomed and the grout and inserts may be revealed without a finish treatment.
2. Jambs for HI-R walls are typically formed using a CMU jamb unit with Icon® inserts. The thermal properties of the jamb should be considered when performing Energy Code compliance calculations.
3. The details show an insulated window sill – choose rigid board insulation with sufficient thickness to meet requirements.
4. Always place and dimension openings with masonry modularity in mind – this will result in greatest cost efficiency.
5. All details are available in Revit® and AutoCAD® – the numbering of the details in this manual corresponds to that used in the Revit® and AutoCAD® files.



**Building a lintel on a form – pre-fabrication is also an option**

Detail 4-2210 - HI-R - Door Head - HI-R Stretcher Used for Lintel

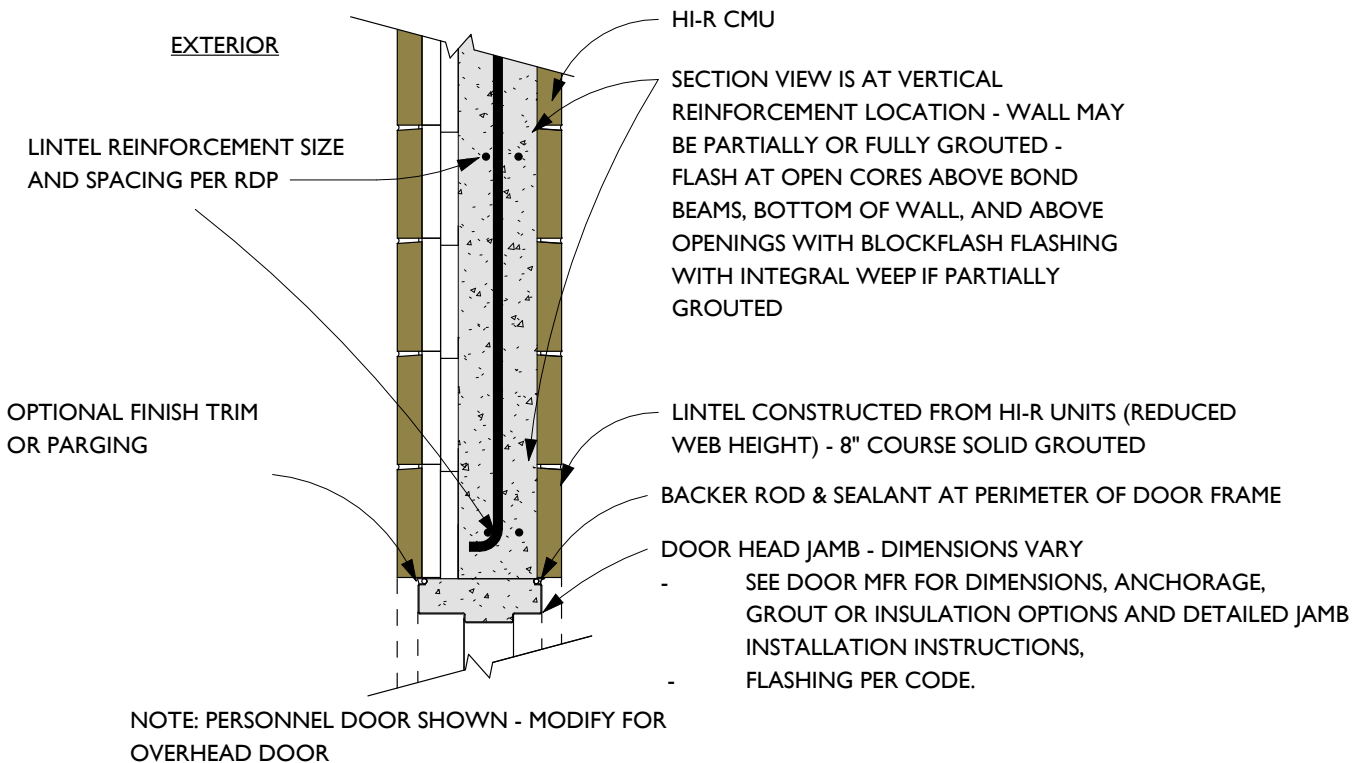

\*THIS DETAIL IS A STANDARD DETAIL. DESIGNERS SHOULD MAKE SITE SPECIFIC INVESTIGATIONS TO DETERMINE ACTUAL DESIGN REQUIREMENTS.

Detail 4-2211 - HI-R - Door Head - HI-R/HI-R-H Closed Bottom Lintel

NOTE: CHECK AVAILABILITY OF HI-R/HI-R-H CLOSED BOTTOM LINTEL UNIT- ONLY AVAILABLE IN CERTAIN REGIONS

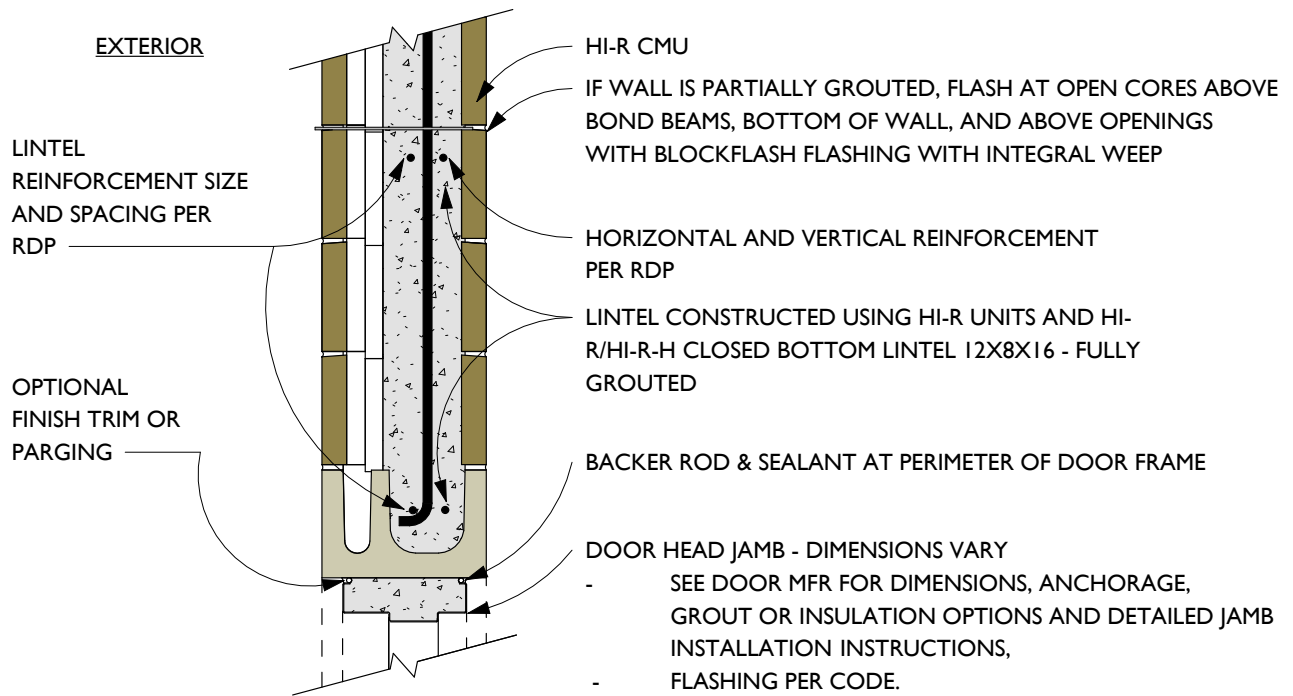

NOTE: PERSONNEL DOOR SHOWN - MODIFY FOR OVERHEAD DOOR

\*THIS DETAIL IS A STANDARD DETAIL. DESIGNERS SHOULD MAKE SITE SPECIFIC INVESTIGATIONS TO DETERMINE ACTUAL DESIGN REQUIREMENTS.

## Door Openings - Jamb

### Detail 4-2212 - HI-R - Door Jamb

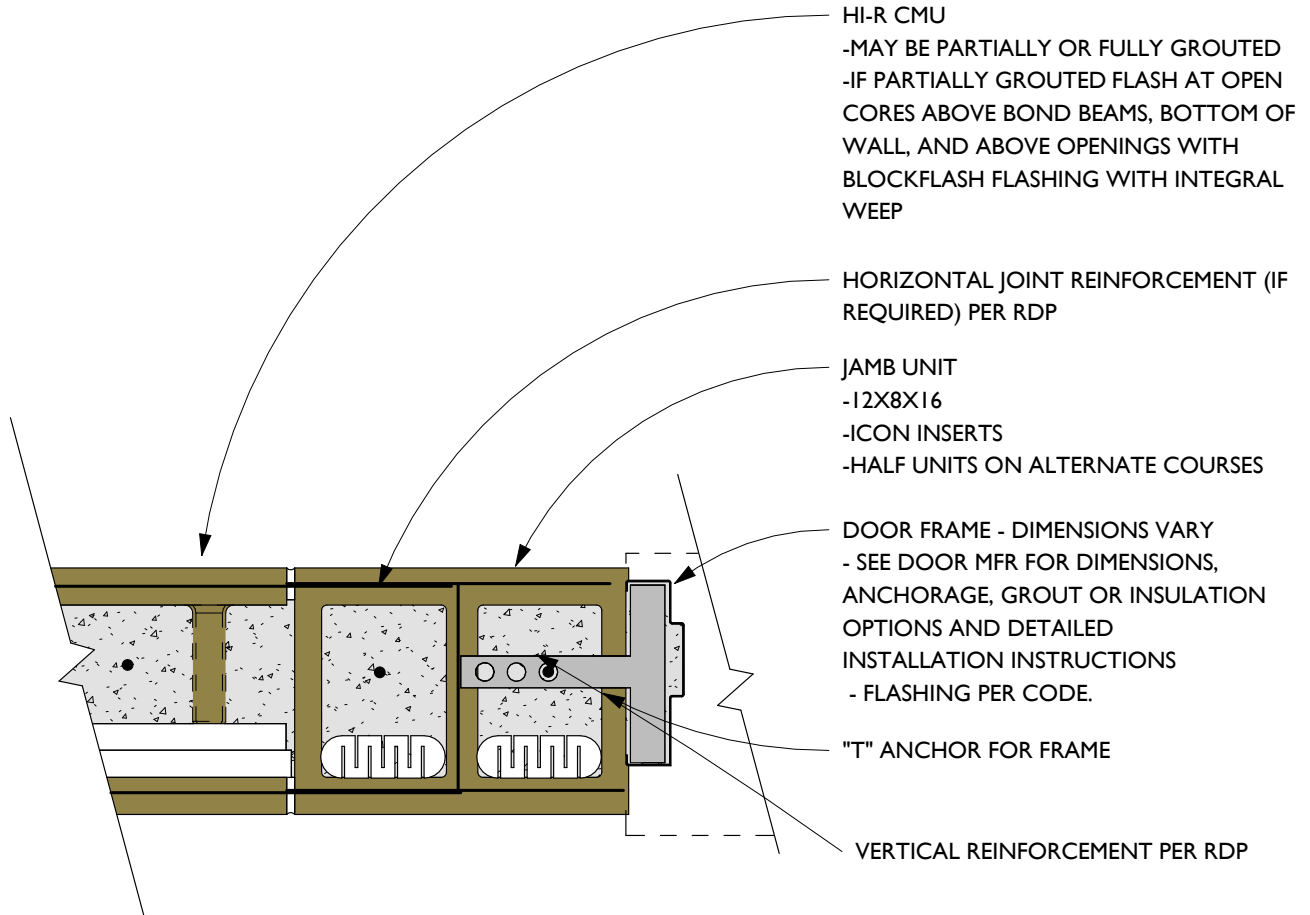

NOTE: PERSONNEL DOOR SHOWN - MODIFY  
FOR OVERHEAD DOOR SELECTED

\*THIS DETAIL IS A STANDARD DETAIL. DESIGNERS SHOULD MAKE SITE SPECIFIC  
INVESTIGATIONS TO DETERMINE ACTUAL DESIGN REQUIREMENTS.

**Additional Notes – Door openings:**

1. See notes to Window openings.
2. All details are available in Revit® and AutoCAD® – the numbering of the details in this manual corresponds to that used in the Revit® and AutoCAD® files.

Detail 4-2301 - HI-R - Precast Plank Bearing Wall

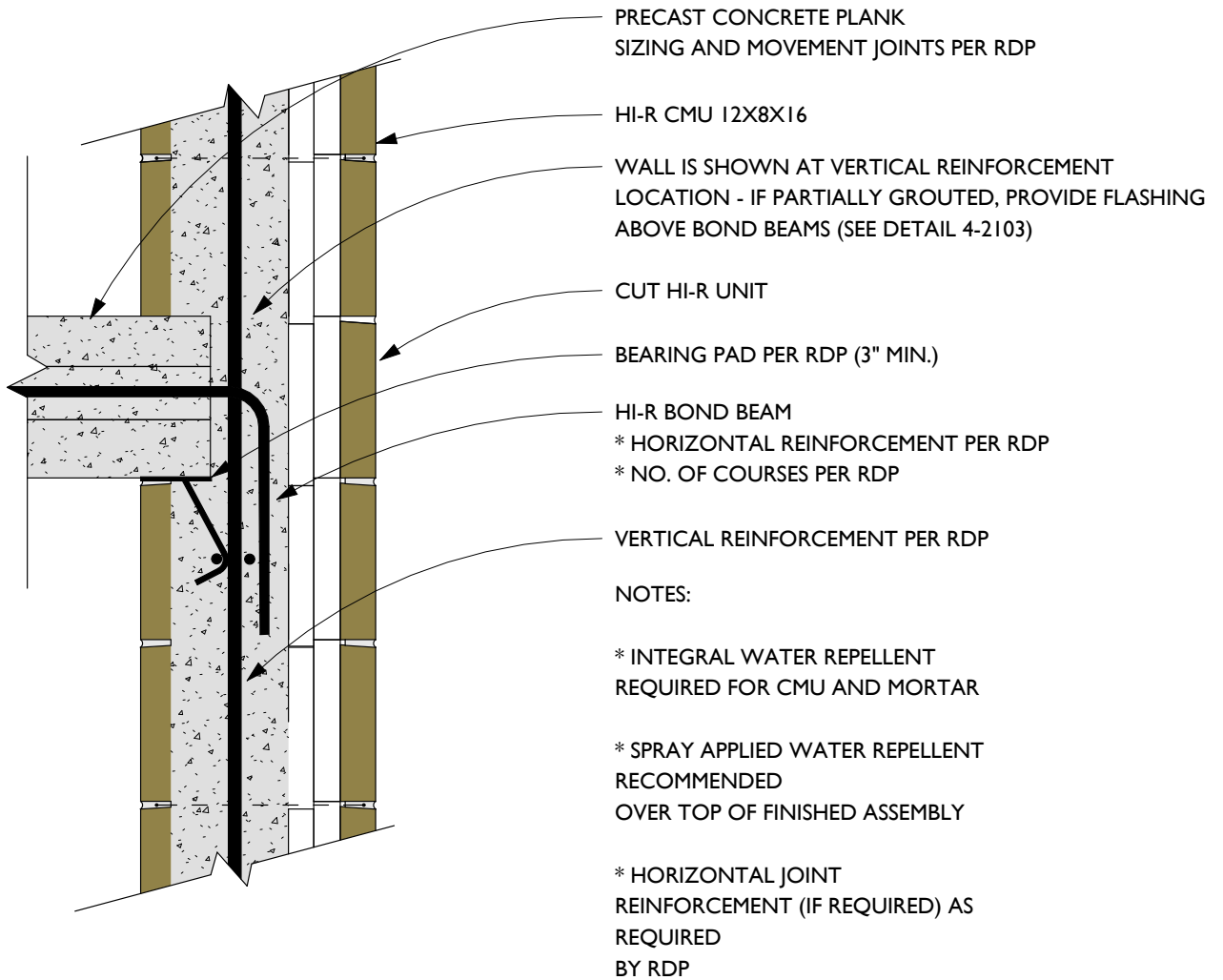

\*THIS DETAIL IS A STANDARD DETAIL. DESIGNERS SHOULD MAKE SITE SPECIFIC INVESTIGATIONS TO DETERMINE ACTUAL DESIGN REQUIREMENTS.

Detail 4-2302 – HI-R – Precast Plank Non-Bearing Wall

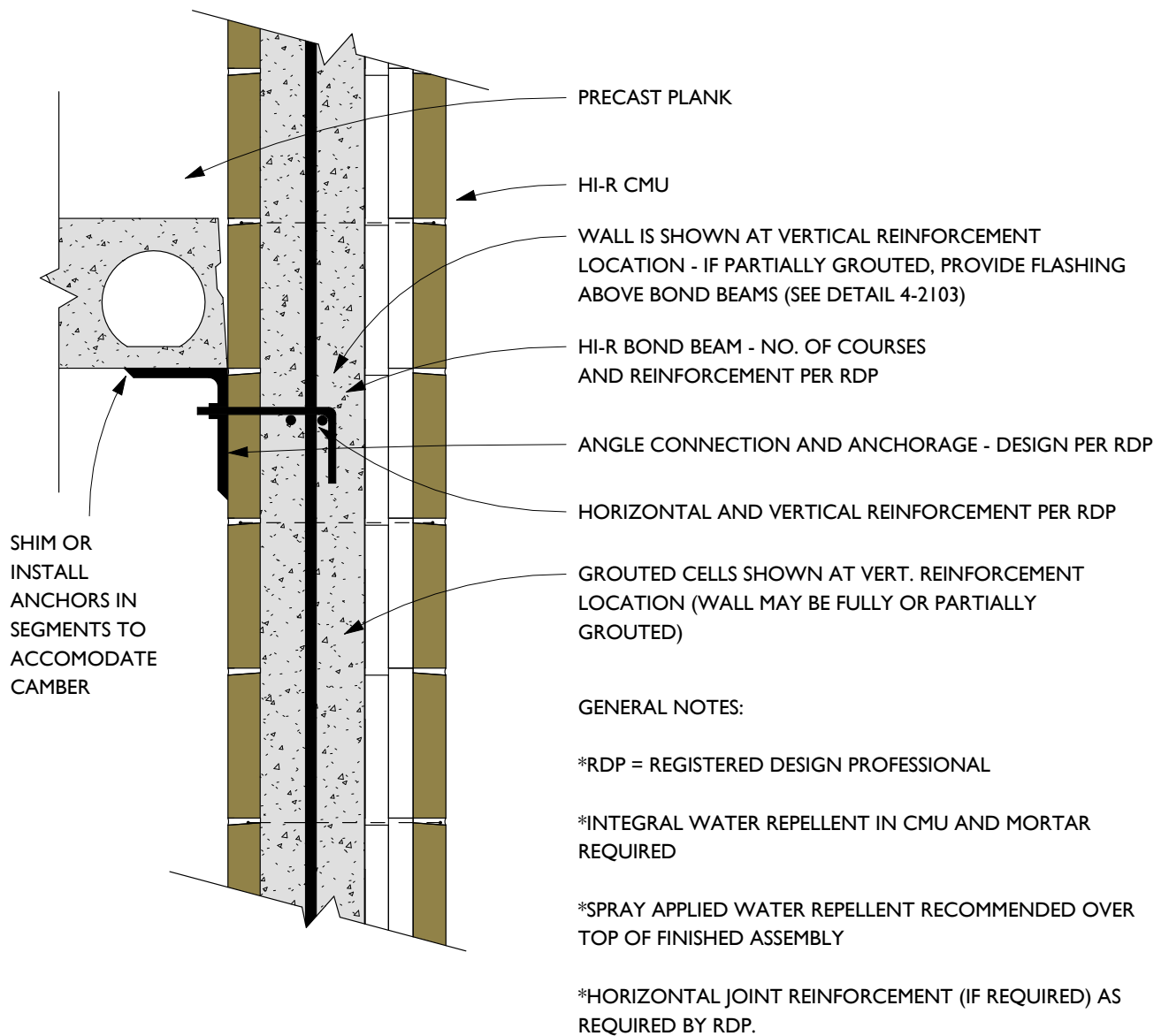

\*THIS DETAIL IS A STANDARD DETAIL. DESIGNERS SHOULD MAKE SITE SPECIFIC INVESTIGATIONS TO DETERMINE ACTUAL DESIGN REQUIREMENTS.

**Additional Notes – Planks:**

1. See notes regarding bond beams – page 34.
2. All details are available in Revit® and AutoCAD® – the numbering of the details in this manual corresponds to that used in the Revit® and AutoCAD® files.

Roof Joist and Parapet

Detail 4-2310 - HI-R - Roof and Parapet - Bearing Wall

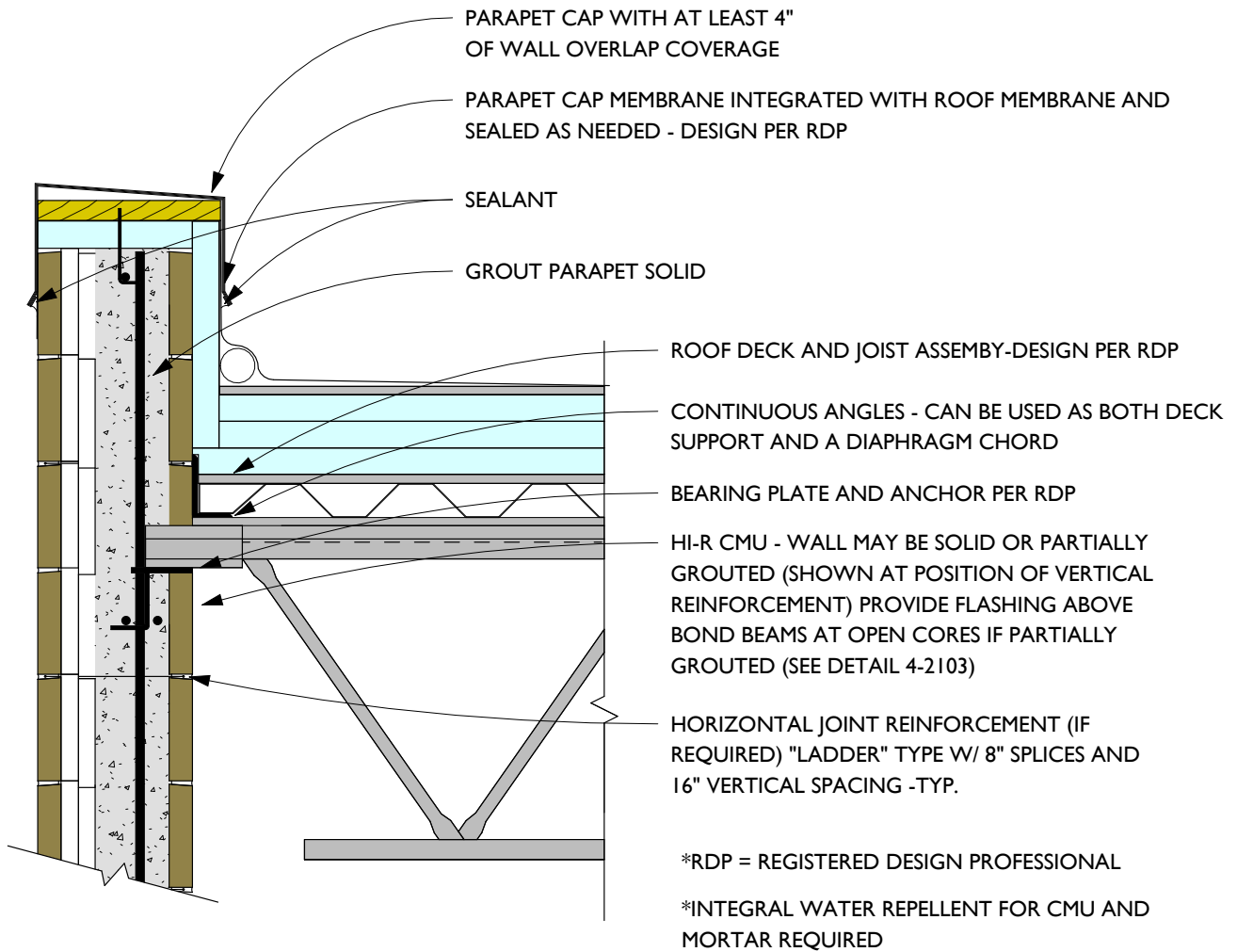

\*THIS DETAIL IS A STANDARD DETAIL. DESIGNERS SHOULD MAKE SITE SPECIFIC INVESTIGATIONS TO DETERMINE ACTUAL DESIGN REQUIREMENTS.

## Roof Joist and Parapet

### Detail 4-2311 - HI-R - Roof and Parapet - Non-Bearing Wall

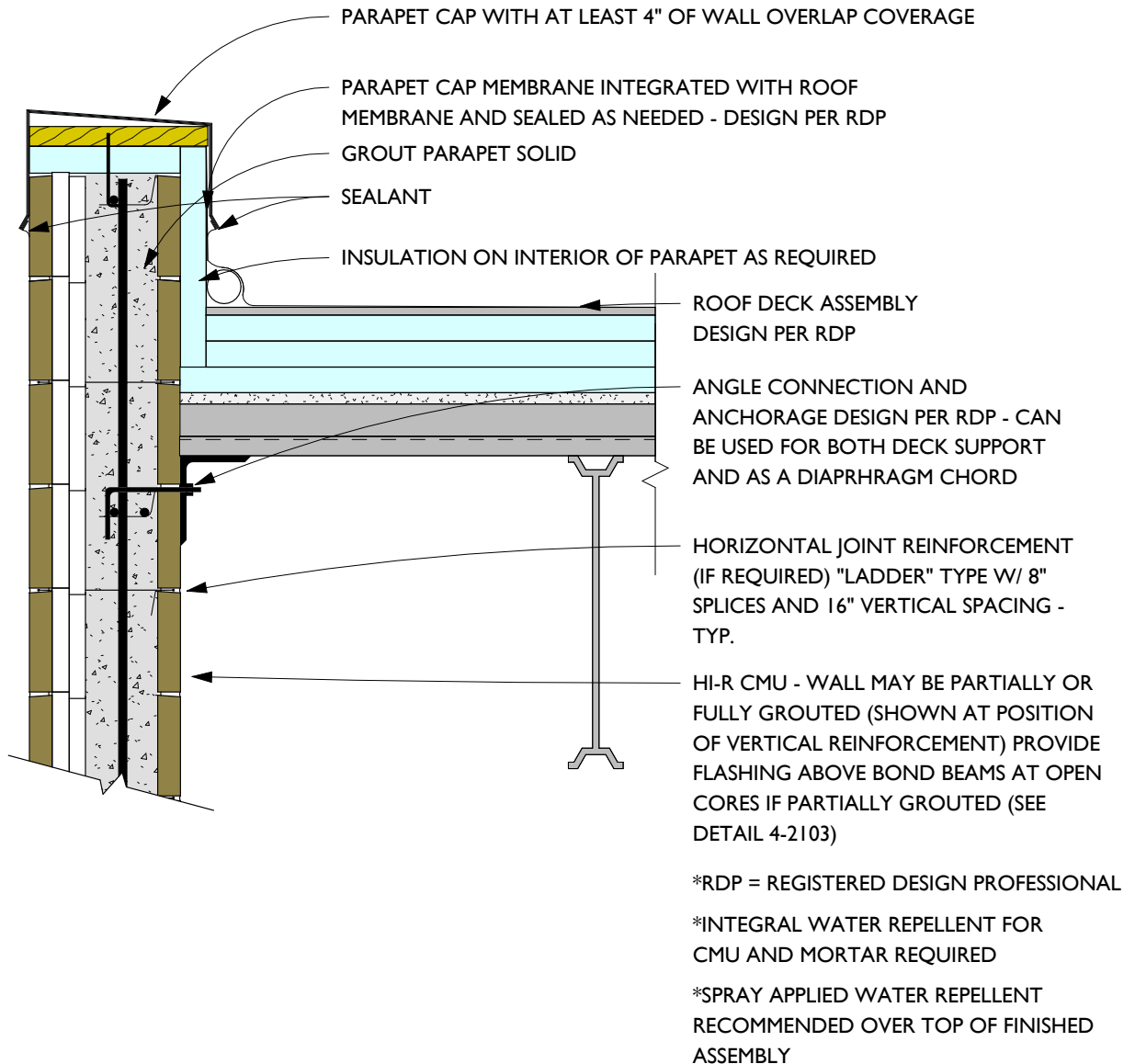

\*THIS DETAIL IS A STANDARD DETAIL. DESIGNERS SHOULD MAKE SITE SPECIFIC INVESTIGATIONS TO DETERMINE ACTUAL DESIGN REQUIREMENTS.

**Additional Notes – Roof Joist and Parapet:**

1. See notes regarding bond beams at page 34.
2. Insulating the inward face of the parapet provides protection against thermal bridging at that location.
3. All details are available in Revit® and AutoCAD® – the numbering of the details in this manual corresponds to that used in the Revit® and AutoCAD® files.

Detail 4-2320 - HI-R - CMU PILASTER - Plan View

EXTERIOR

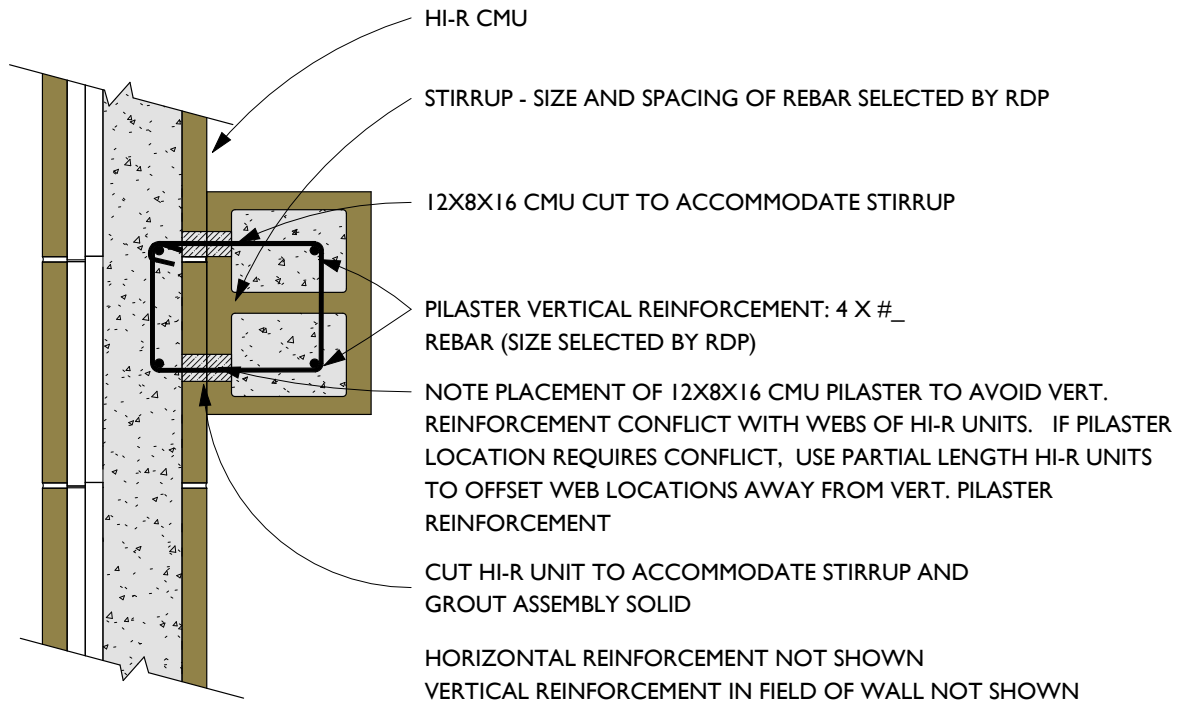

EXAMPLE ONLY; NOT FOR CONSTRUCTION -  
REINFORCEMENT REQUIREMENTS VARY

RDP = REGISTERED DESIGN PROFESSIONAL

\*THIS DETAIL IS A STANDARD DETAIL. DESIGNERS SHOULD MAKE SITE SPECIFIC INVESTIGATIONS TO DETERMINE ACTUAL DESIGN REQUIREMENTS.

Detail 4-2321 - HI-R - CMU PILASTER - Section View

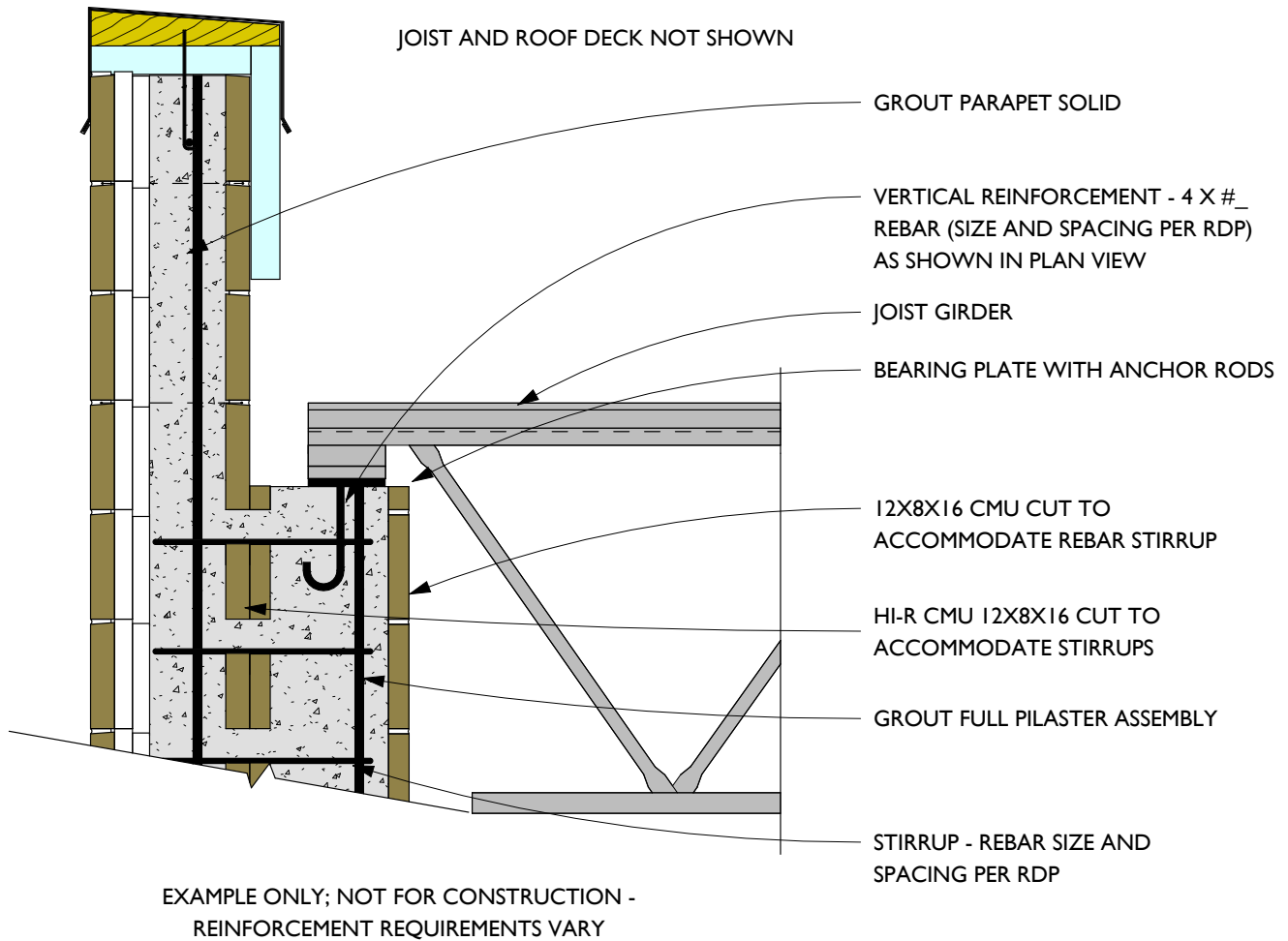

\*THIS DETAIL IS A STANDARD DETAIL. DESIGNERS SHOULD MAKE SITE SPECIFIC INVESTIGATIONS TO DETERMINE ACTUAL DESIGN REQUIREMENTS.

**Additional Notes – Pilaster:**

1. See notes regarding bond beams.
2. Pilasters are often a cost-effective way to meet structural requirements to support the building roof assembly
3. Insulating the inward face of the parapet provides protection against thermal bridging at that location.
4. All details are available in Revit® and AutoCAD® – the numbering of the details in this manual corresponds to that used in the Revit® and AutoCAD® files.



---

# HI-R-H Construction Details

---

# HI-R-H Pre-Insulated Wall System

Spec-Thermal® HI-R-H and HI-R-H HALF HIGH are pre-insulated fully grouted masonry wall systems that offer superior thermal performance. They offer the ability to meet Energy Code requirements with single wythe masonry even in the most challenging climate zones.

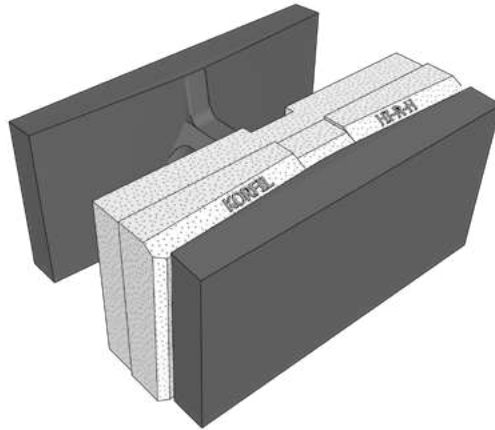

**12×8×16 Spec-Thermal® HI-R-H Unit  
Fully Grouted Wall Assemblies**

## Applications

Double exposed single wythe masonry walls with durable architectural finishes for conditioned spaces in all Climate Zones.

- Single wythe walls for conditioned spaces in all Climate Zones with furring/wallboard and/or interior or exterior insulation.
- Load-bearing walls above and/or below grade.

## Thermal Performance

- Two part offset interlocking 3.0", 3.5" or 4" insulation insert with lapped joints. Note to specifiers: Designating the Insulation thickness in the plans and specifications will avoid confusion i.e., **HI-R-H 3"**, **HI-R-H 3.5"** or **HI-R-H 4"**.
- The HI-R-H wall systems minimize thermal bridging and use thick, interlocking Korfil® insulation inserts and interior exposed thermal mass to provide excellent energy conservation.
- Superior thermal performance to HI-R products.

## Fully Grouted Wall System

- Barrier wall performance resists moisture penetration and condensation issues with use of integral water repellent in block and mortar and post-applied water repellent.
- **Four hour** fire rating is typical. Check with manufacturer for details.
- No additional air barrier or vapor retarder is required with fully grouted masonry walls (assumes use of integral water repellent in unit and mortar)
- Great choice for structures designed to be resilient against natural hazards and pests
- Great choice for demanding applications requiring extensive reinforcement.





## Construction Efficiency and Value

- Shape eases placement even with tight reinforcement spacing.
- No modification to stretcher unit required for bond beam construction.
- Utilities (plumbing and electrical) readily fit in unit cores and horizontal grout spaces
- Single trade installs interior and exterior finishes, structure and insulation in one step.
- Unit Width: 12" (10" in some regions only – please check with your representative).

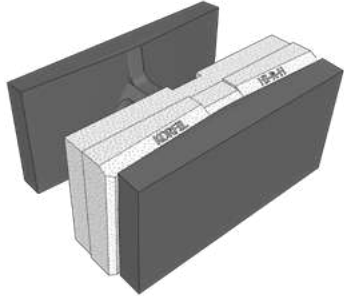

# Wall System: HI-R-H

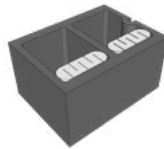
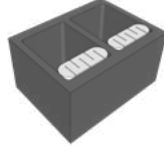
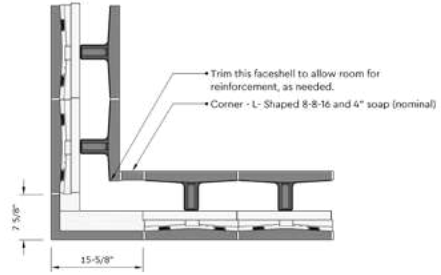
## Summary of System Component Options:

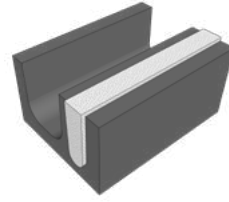
	<p><b>Main wall units:</b>          HI-R-H 12×8×16 Stretcher Unit          Choose insulation thickness: 3", 3.5" or 4"</p> <p><b>Bond Beams:</b>          Use HI-R-H Stretcher Unit - no modifications needed</p>			
<p><b>Control Joints:</b>          HI-R-H Sash/Jamb Unit* or          CMU Sash Unit (Icon® Insulation)</p>		 <p>HI-R-H Sash/Jamb Unit</p>	 <p>CMU Sash Unit with Icon® Inserts</p>	 <p>CMU Jamb Unit with Icon® Inserts</p>
<p><b>Jambs:</b>          HI-R-H Sash/Jamb Unit* or          CMU Jamb Unit (Icon® Insulation)</p>				
<p><b>Corners:</b>          L-Shaped CMU fitting with EPS Insulation</p>				
<p><b>Lintels:</b>          HI-R-H units or          HI-R/HI-R-H Closed Bottom Lintel*</p>		 <p>HI-R-H Unit</p>	 <p>HI-R/HI-R-H Closed Bottom Lintel Unit</p>	

\* Availability may be limited in some regions. Please confirm local availability before specifying.

Detail 4-3000 - HI-R-H -Concrete Foundation

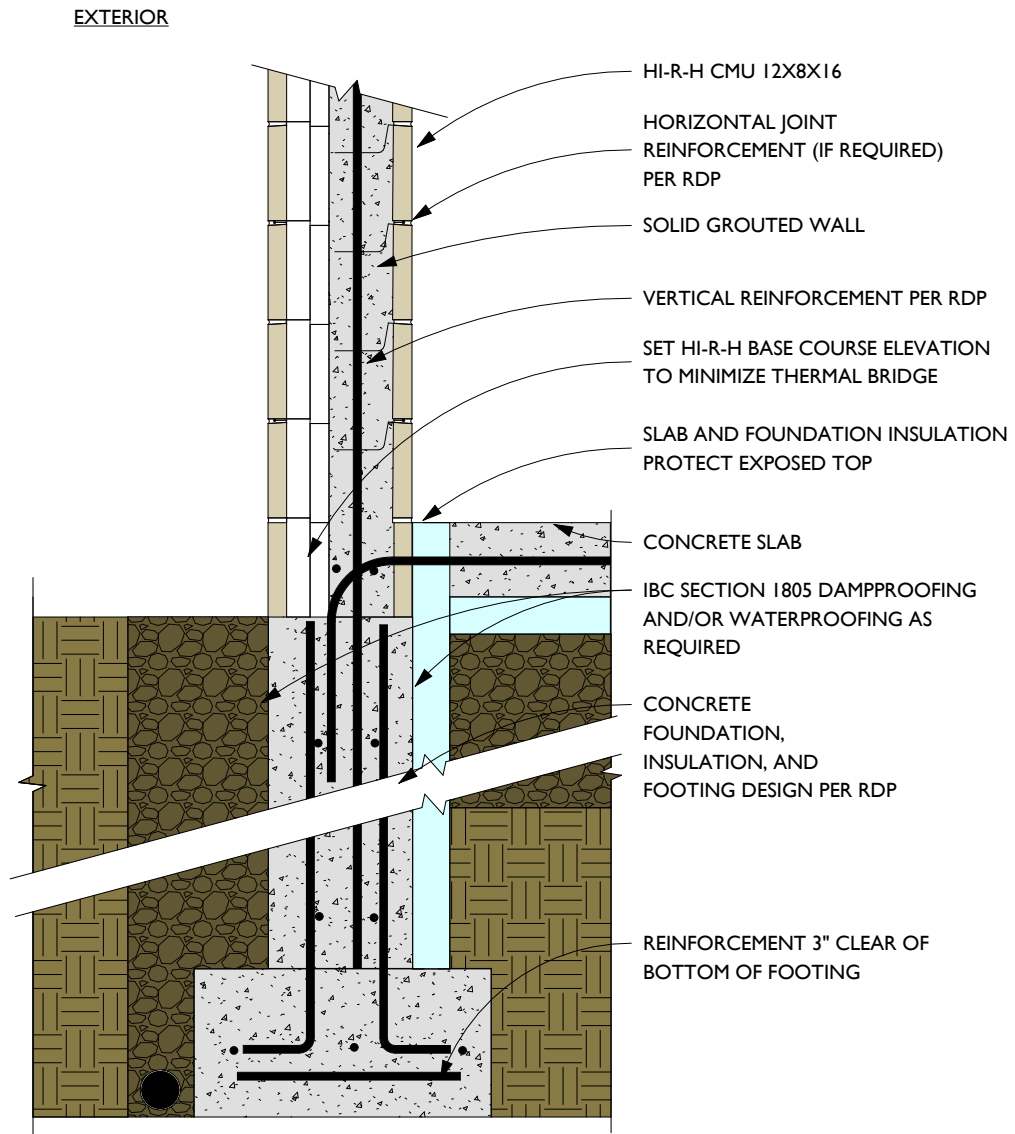

\*THIS DETAIL IS A STANDARD DETAIL. DESIGNERS SHOULD MAKE SITE SPECIFIC INVESTIGATIONS TO DETERMINE ACTUAL DESIGN REQUIREMENTS.

Detail 4-3001 - HI-R-H - Foundation - CMU

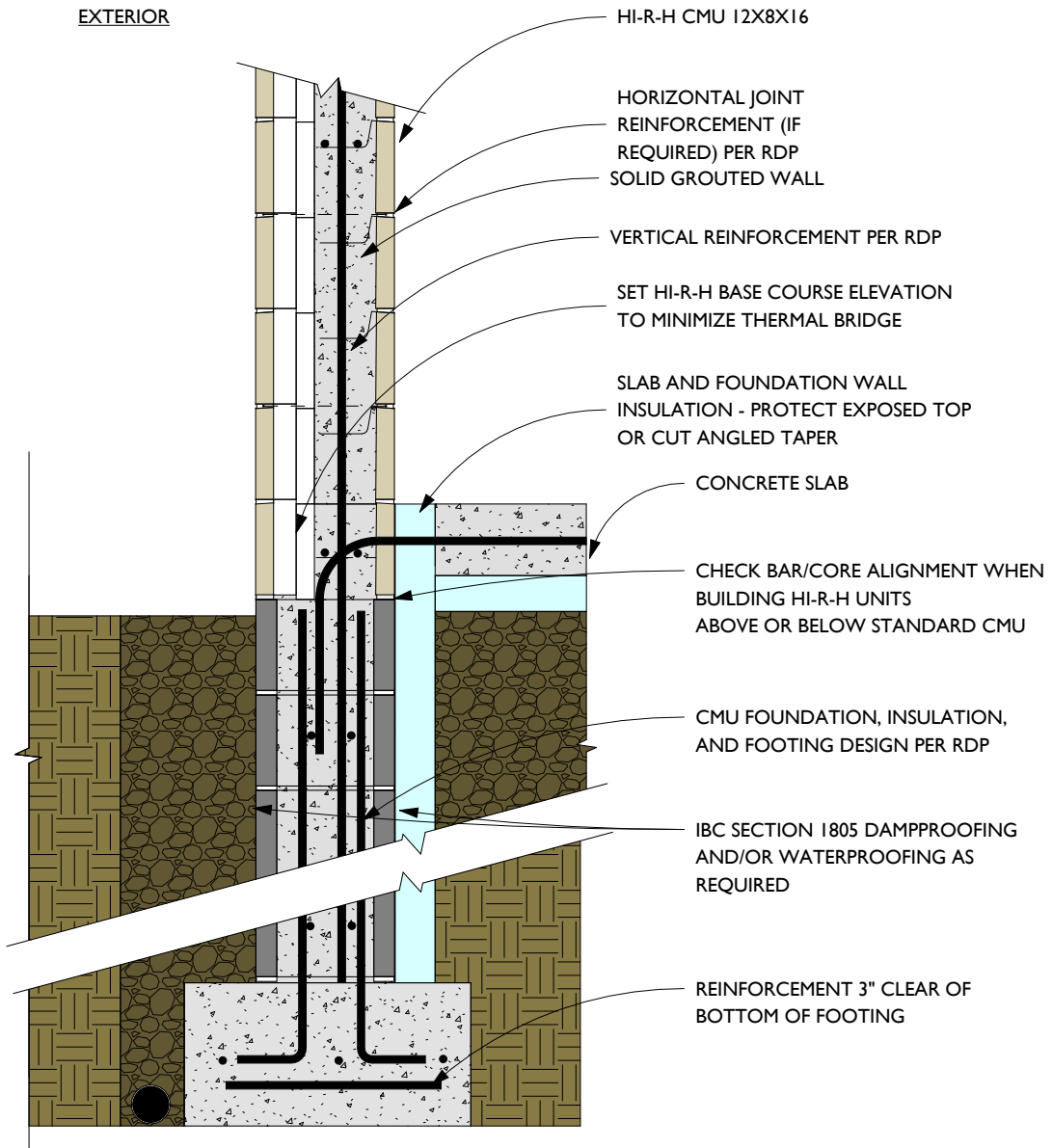

\*THIS DETAIL IS A STANDARD DETAIL. DESIGNERS SHOULD MAKE SITE SPECIFIC INVESTIGATIONS TO DETERMINE ACTUAL DESIGN REQUIREMENTS.

Detail 4-3002 - HI-R-H - Foundation - HI-R-H Stem Wall Slab at Grade

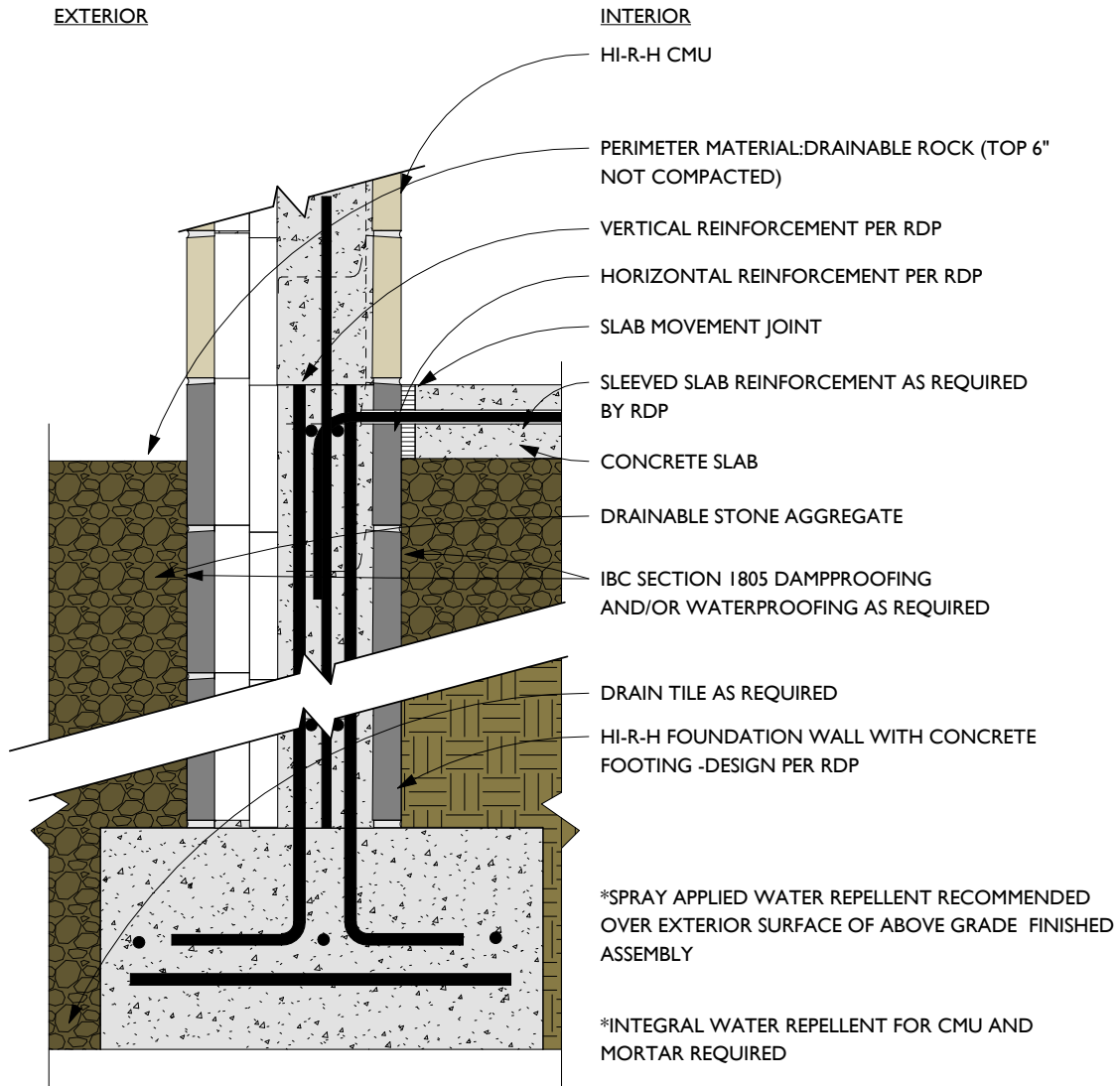

\*RDP = REGISTERED DESIGN PROFESSIONAL

\*THIS DETAIL IS A STANDARD DETAIL. DESIGNERS SHOULD MAKE SITE SPECIFIC INVESTIGATIONS TO DETERMINE ACTUAL DESIGN REQUIREMENTS.

Detail 4-3003 - HI-R-H - Foundation - HI-R-H Basement Wall

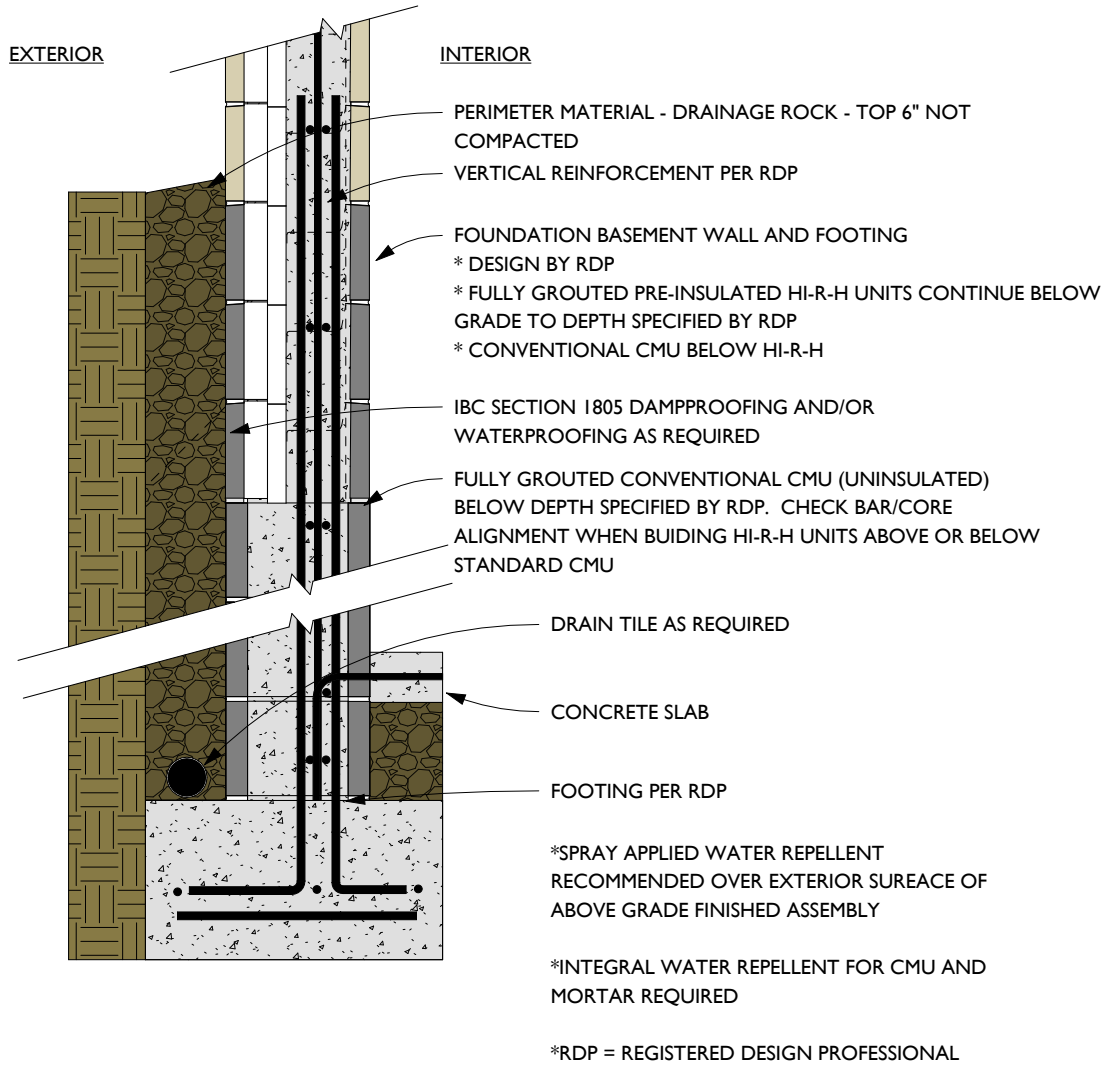

\*THIS DETAIL IS A STANDARD DETAIL. DESIGNERS SHOULD MAKE SITE SPECIFIC INVESTIGATIONS TO DETERMINE ACTUAL DESIGN REQUIREMENTS.

1. In this manual, we present three choices for foundation wall construction: poured in place concrete, CMU, and pre-insulated CMU – Spec-Thermal® HI-R or HI-R-H. Each will meet structural requirements when properly designed. Both the concrete and traditional CMU footing/stem/crawl space/foundations will typically require insulation placement either to the exterior or interior (or both) of the foundation wall. The HI-R-H foundation wall is pre-insulated with integral insulation in the unit. For below grade applications, delete insulation based upon web shear capacity in Structural Design Manual (this will be approximately at frost depth). Consult with Structural and/or Geo-technical Engineers for appropriate below-grade design, insulation material and placement.
2. Check local Code for slab insulation requirements – if the slab is on grade, address the thermal bridge at the slab by either placing interior or exterior insulation at this location. Insulation placed at the exterior will typically require some form of hardened protective covering. For insulation requirements see e.g., IECC/IRC Section R402.2.10/N1102.2.10 Slab-On-Grade Floors.
3. The use of pre-insulated block for the foundation and above grade walls provides a simple way to meet insulation requirements for both types of walls. It also has structural benefits as the foundation wall is fully supported directly by the engineered soils. Full grout should be used for the foundation wall. The insulation is protected integral insulation which eliminates insulation damage concerns.
4. Generally a damp-check needs be placed above the top of the damp-proofing or waterproofing for foundation walls, basement walls, or foundations. For below-grade masonry basement walls an additional damp check at the masonry starting course and above the damp-proofing or waterproofing for slabs and floors will further control moisture. An above-grade masonry course with flashing also performs as a damp-check.
5. A tapered (30° from horizontal) 6" zone of free-draining gravel extending from the height of the finished floor to the top of the engineered soil may be substituted for the concrete apron shown.
6. To provide robust protection of single wythe walls from moisture penetration, we recommend integral water repellent (IWR) be used in both the block and mortar. The IWR in the block and mortar need to be chemically compatible (check with block manufacturer for recommendations). Some exceptions to using IWR may apply such as for California masonry core testing. To provide additional protection, we recommend use of a post-applied breathable water repellent over the finished wall after cleaning has been completed and approved and the walls are completely dry.
7. If the zone near the above-grade wall or foundation wall is to be landscaped, do not place plant life, roots, irrigation, fertilizers or other chemicals within 3 feet of the above-grade wall or foundation wall. Isolate the above-grade wall, foundation wall, footing, foundation, and slab from such elements.
8. All details are available in Revit® and AutoCAD® – the numbering of the details in this manual corresponds to that used in the Revit® and AutoCAD® files.

Detail 4-3100 - HI-R-H Bond Beam

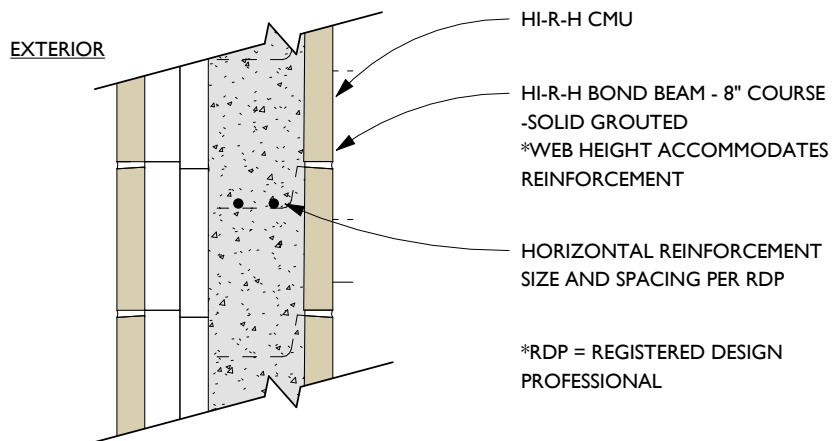

\*THIS DETAIL IS A STANDARD DETAIL. DESIGNERS SHOULD MAKE SITE SPECIFIC INVESTIGATIONS TO DETERMINE ACTUAL DESIGN REQUIREMENTS.

Horizontal Joint Reinforcement

Detail 4-3101 - HI-R-H Horizontal Joint Reinforcement

EXTERIOR

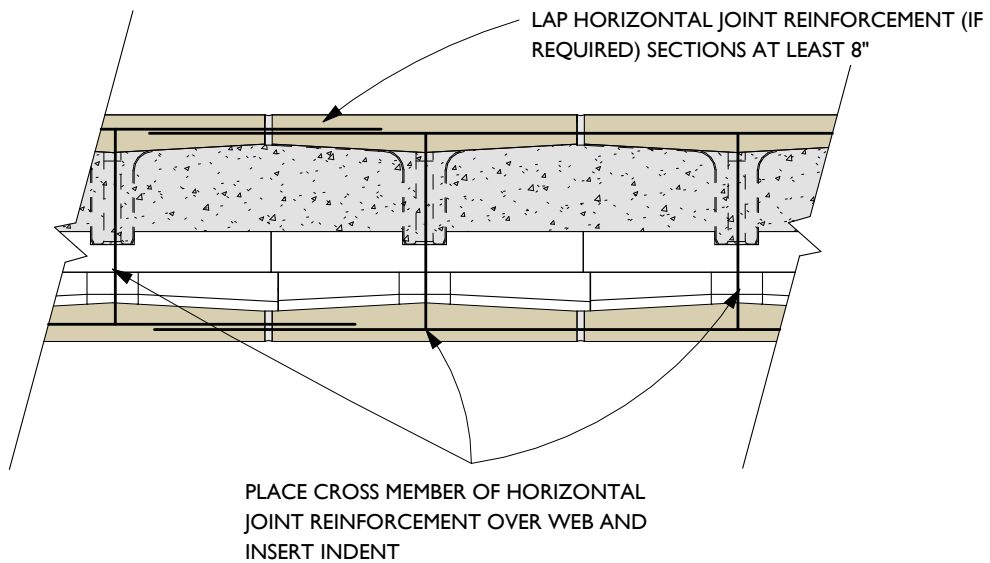
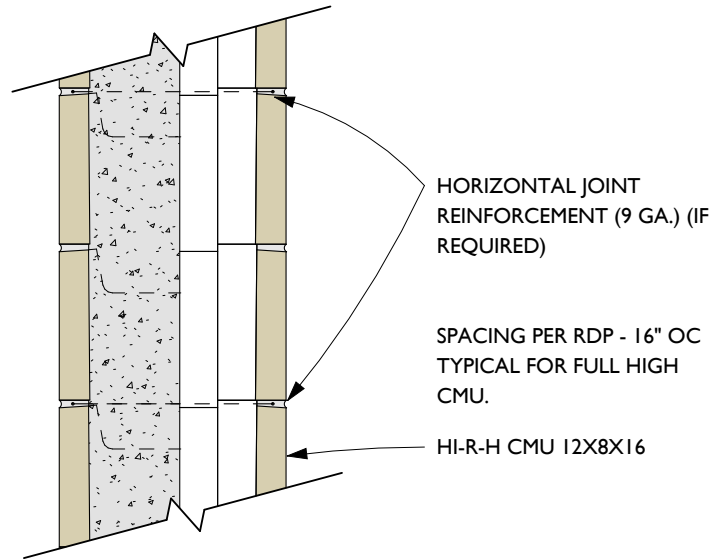

\*THIS DETAIL IS A STANDARD DETAIL. DESIGNERS SHOULD MAKE SITE SPECIFIC INVESTIGATIONS TO DETERMINE ACTUAL DESIGN REQUIREMENTS.

Control Joints

Detail 4-3109 - HI-R-H - Piers Control Joints and Jamb - HI-R-H Jamb Unit

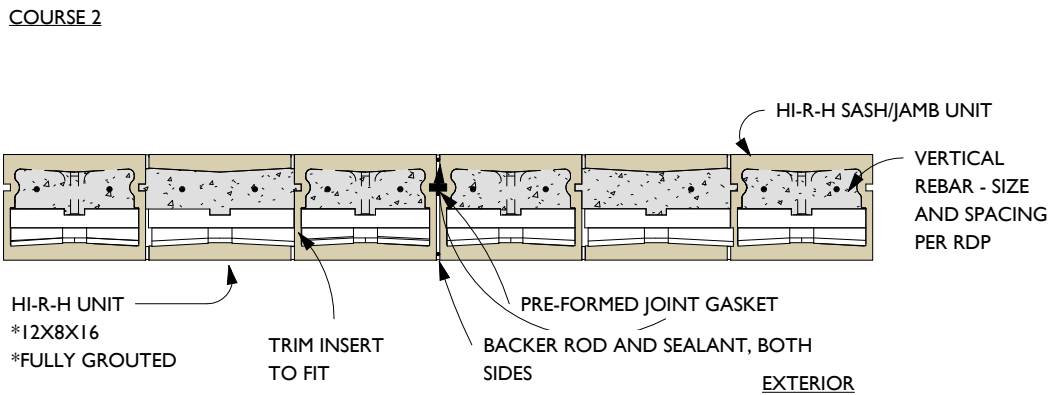
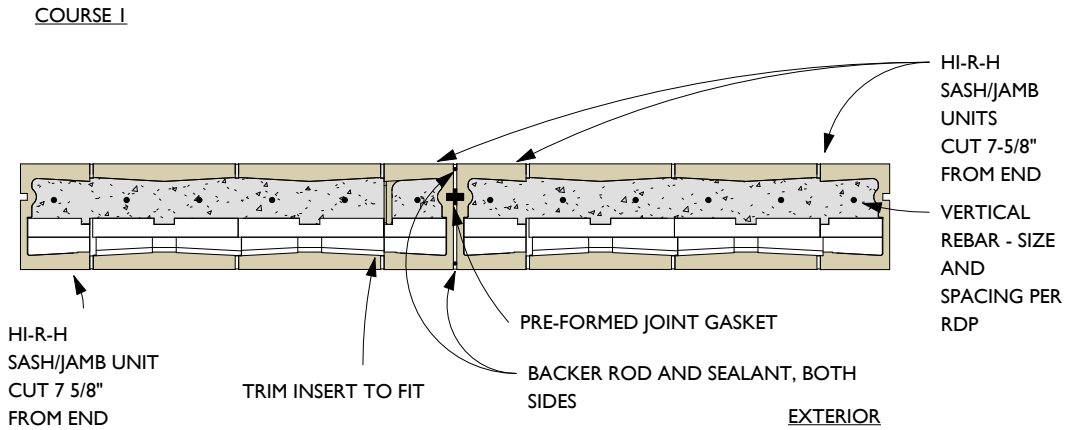

PLEASE CONFIRM LOCAL AVAILABILITY OF HI-R-H SASH/JAMB UNIT PRIOR TO SPECIFYING

\*THIS DETAIL IS A STANDARD DETAIL. DESIGNERS SHOULD MAKE SITE SPECIFIC INVESTIGATIONS TO DETERMINE ACTUAL DESIGN REQUIREMENTS.

Control Joints

Detail 4-3110 - HI-R-H - Piers Control Joints and Jamb - HI-R-H Jamb Unit Hooked Reinforcement

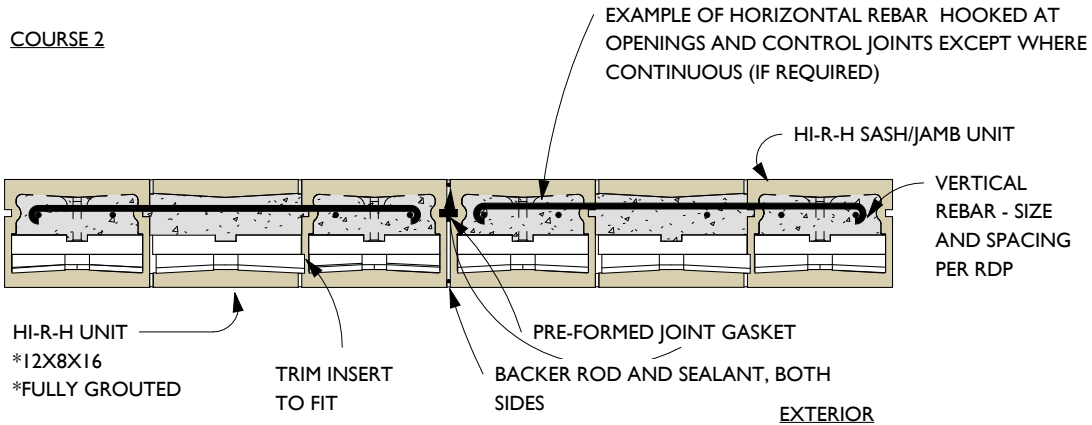
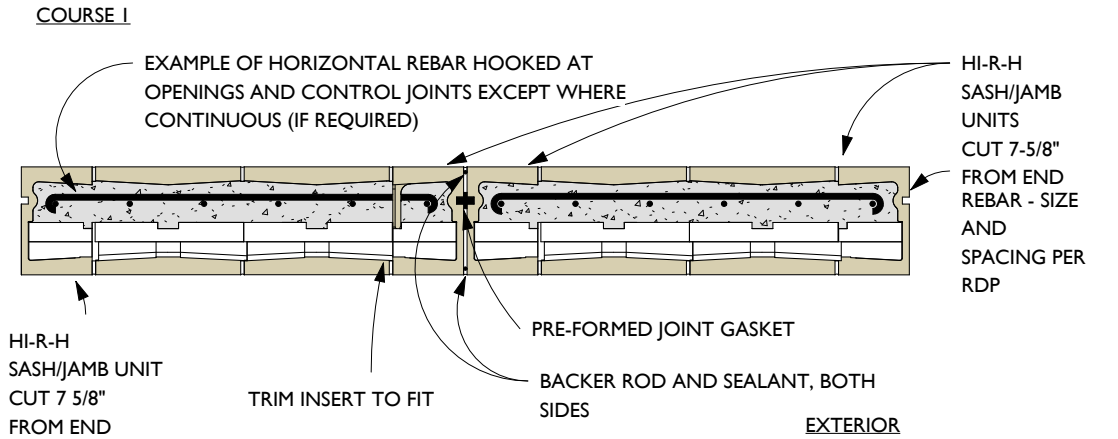

PLEASE CONFIRM LOCAL AVAILABILITY OF HI-R-H SASH/JAMB UNIT PRIOR TO SPECIFYING

\*THIS DETAIL IS A STANDARD DETAIL. DESIGNERS SHOULD MAKE SITE SPECIFIC INVESTIGATIONS TO DETERMINE ACTUAL DESIGN REQUIREMENTS.

## Control Joints

### Detail 4-3111 - HI-R-H - Control Joint - CMU Sash

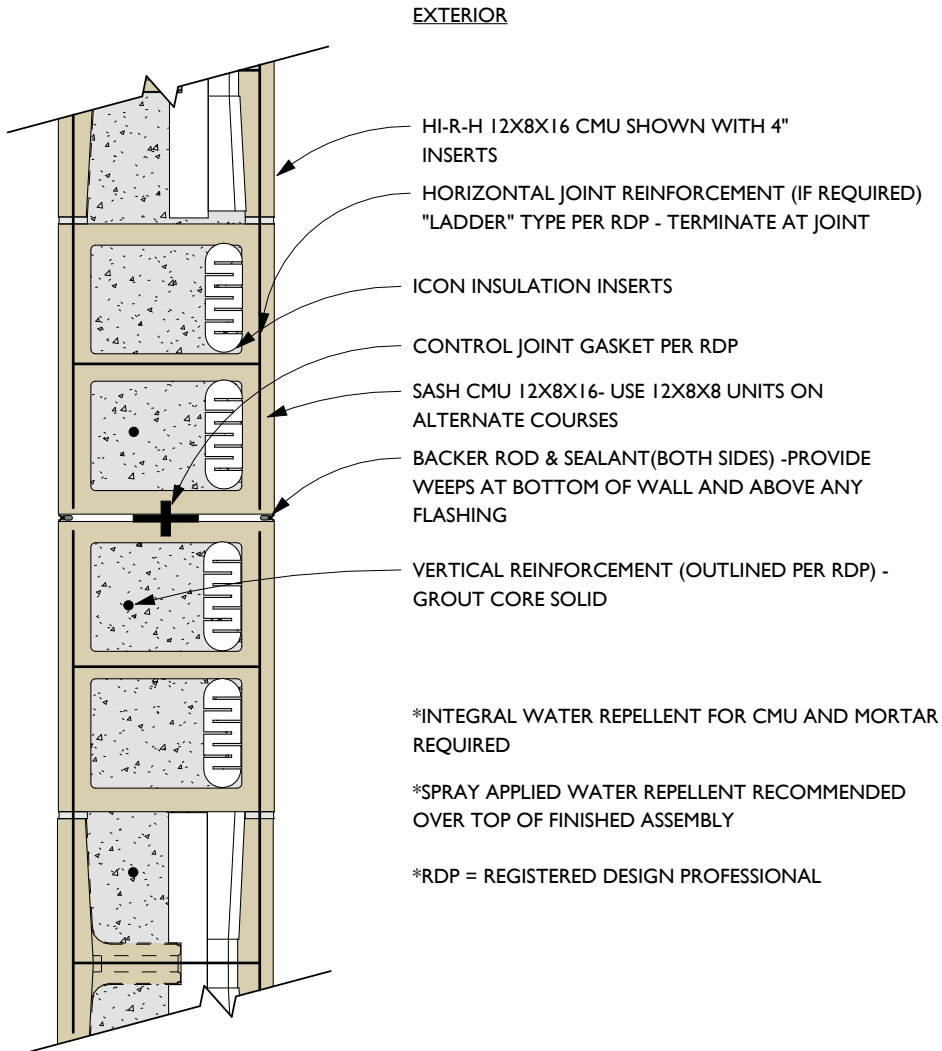

\*THIS DETAIL IS A STANDARD DETAIL. DESIGNERS SHOULD MAKE SITE SPECIFIC INVESTIGATIONS TO DETERMINE ACTUAL DESIGN REQUIREMENTS.

## Control Joint

### Detail 4-3112 - HI-R-H - Control Joint - HI-R-H Sash/Jamb Unit

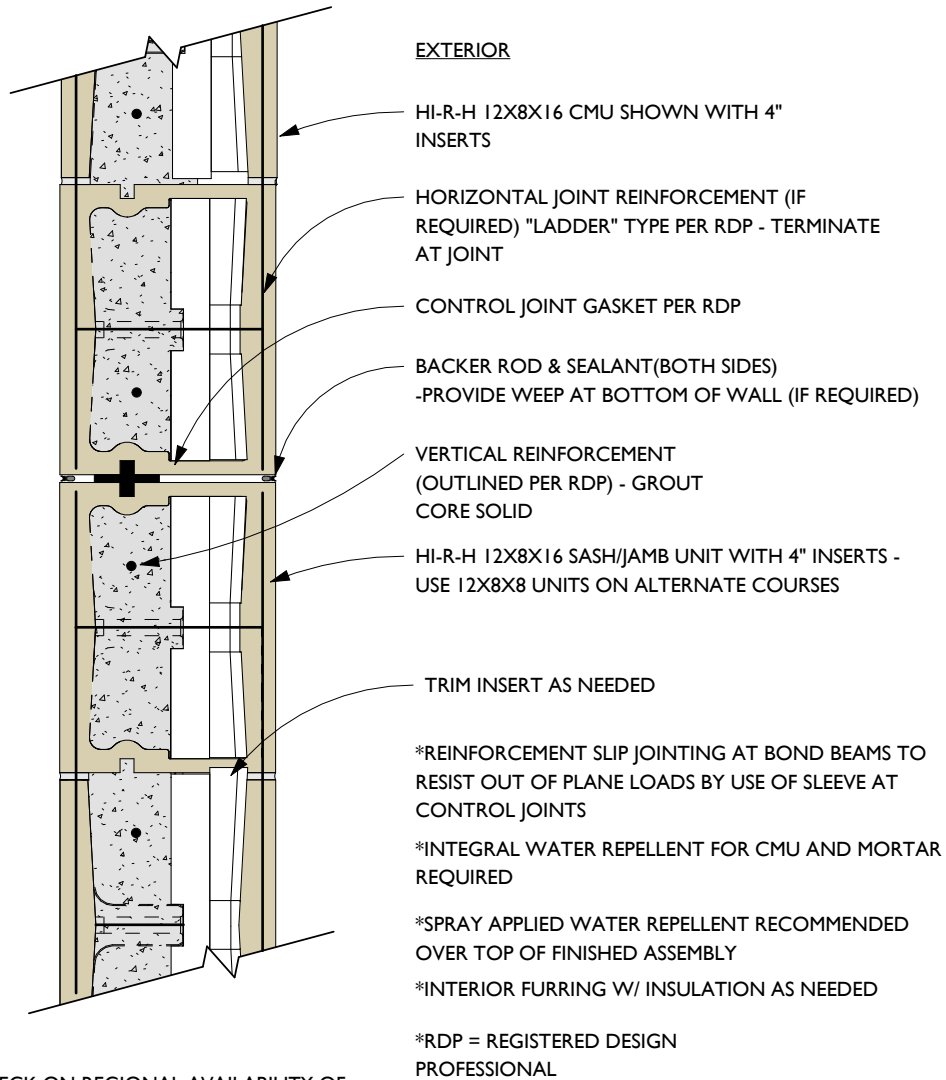

NOTE: CHECK ON REGIONAL AVAILABILITY OF HI-R-H HALF HIGH SASH/JAMB UNIT BEFORE SPECIFYING

\*THIS DETAIL IS A STANDARD DETAIL. DESIGNERS SHOULD MAKE SITE SPECIFIC INVESTIGATIONS TO DETERMINE ACTUAL DESIGN REQUIREMENTS.

## Relief Joint

### Detail 4-3113 - HI-R-H - Relief Joint - Continuous Reinforcement

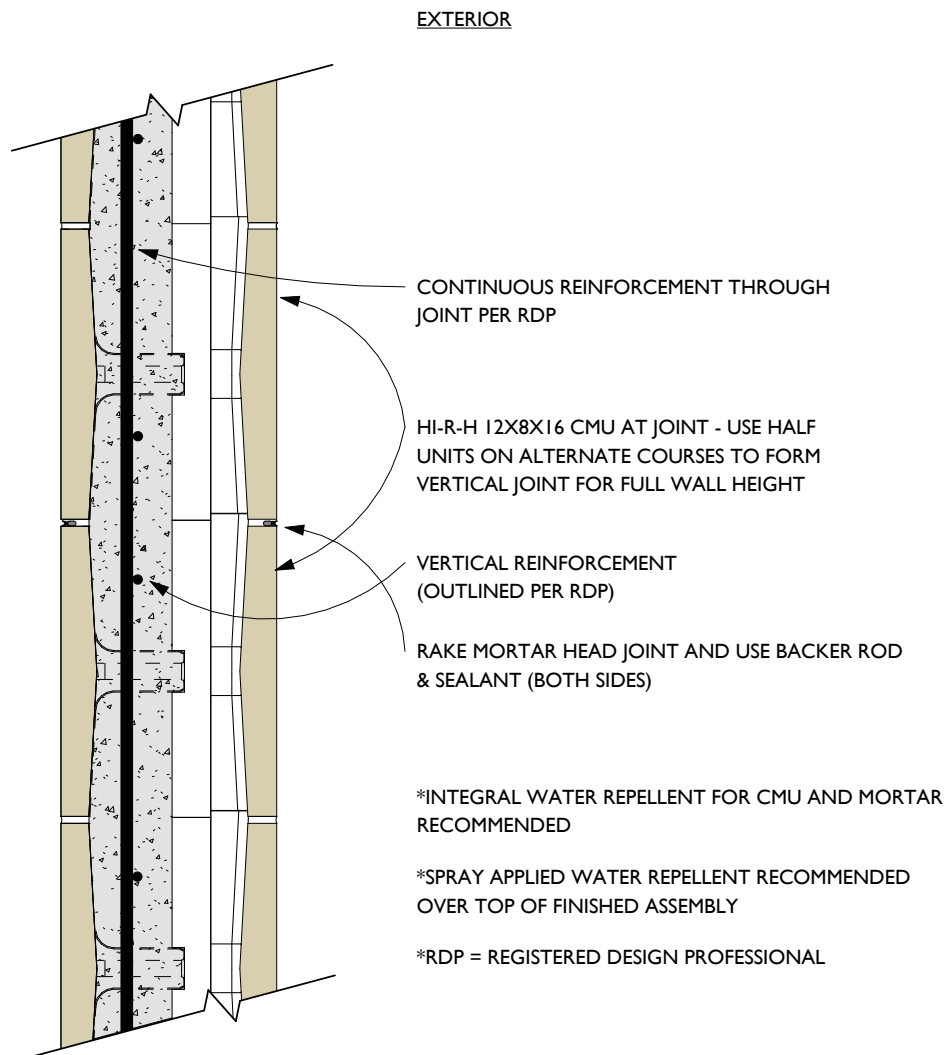

\*THIS DETAIL IS A STANDARD DETAIL. DESIGNERS SHOULD MAKE SITE SPECIFIC INVESTIGATIONS TO DETERMINE ACTUAL DESIGN REQUIREMENTS.

**Additional Notes – Bond Beams and Joints:**

1. Bond beams are typically built using HI-R-H units without the need for any modifications due to the unit's reduced web height.
2. The HI-R-H system is designed to accommodate 9ga. ladder type horizontal joint reinforcement. The insulation inserts have a slight indentation that aligns with the unit webs. HJR should be placed with the cross rods located at these indentations and block webs. 16" spacing of the cross rods is typical.
3. Control joints are a method to assist in controlling cracking in concrete masonry walls by allowing discrete panels in the field of a larger wall to accommodate shrinkage. There are a variety of methods to construct a control joint.
4. There are a variety of construction joints with differing names and purposes (and consistency of usage has been an issue). The joints shown in this manual are used with these meanings:
  - **Control Joint** – A joint used to break up a large field of concrete masonry into discrete panels for the purpose of allowing shrinkage and mitigating cracking.
  - **Movement Joint** – A generic term for a joint that may be intended to serve in multiple functions or accommodate multiple sources of movement.
  - **Relief Joint** – A weakened section of reinforced concrete masonry used to control and isolate the formation of shrinkage related cracks.
5. Though not depicted here, another important use for joints is in areas where there are interfaces between materials that may have different expansion properties. One example would be placing a section of clay brick (tends to expand over time) above or below a section of concrete masonry (tends to shrink over time) in a wall. Placing a joint between the differing materials will accommodate any slight differential in expansion/contraction properties.
6. In general, the specific spacing and placement of control joints for a project should be determined and specified by the project structural engineer who can design the joint spacing in the most efficient manner. Refer to the CMHA (formerly NCMA) TEK notes for required horizontal reinforcement for crack control based on upon joint sizes and locations selected by RDP. Horizontal reinforcement can be provided by either use of horizontal joint reinforcement or horizontal reinforcing rebar.
7. For best results, **remember masonry modularity when placing joints (also true for designing the length and height for walls and the size and placement of openings)** This means these locations should be in multiples of 8 inches from the end of the wall. Designing with modularity in mind will result in optimal efficiency when the wall is built, because if the dimensions are not consistent with masonry modularity then the mason contractor will have to cut units in the field to fit the design.

## Corners

### Detail 4-3120 - HI-R-H - Corner - CMU Fitting - Course 1

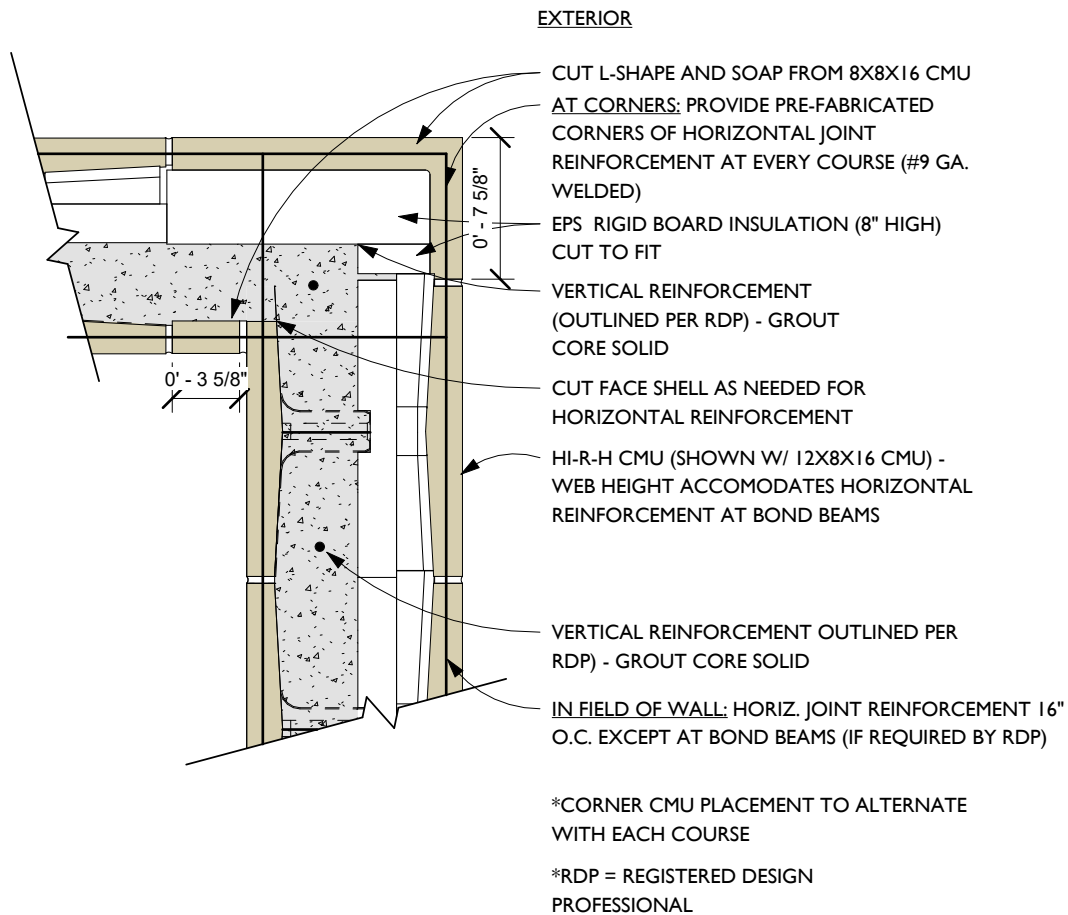

\*THIS DETAIL IS A STANDARD DETAIL. DESIGNERS SHOULD MAKE SITE SPECIFIC INVESTIGATIONS TO DETERMINE ACTUAL DESIGN REQUIREMENTS.

## Corners

### Detail 4-3121 - HI-R-H - Corner - CMU Fitting - Course 2

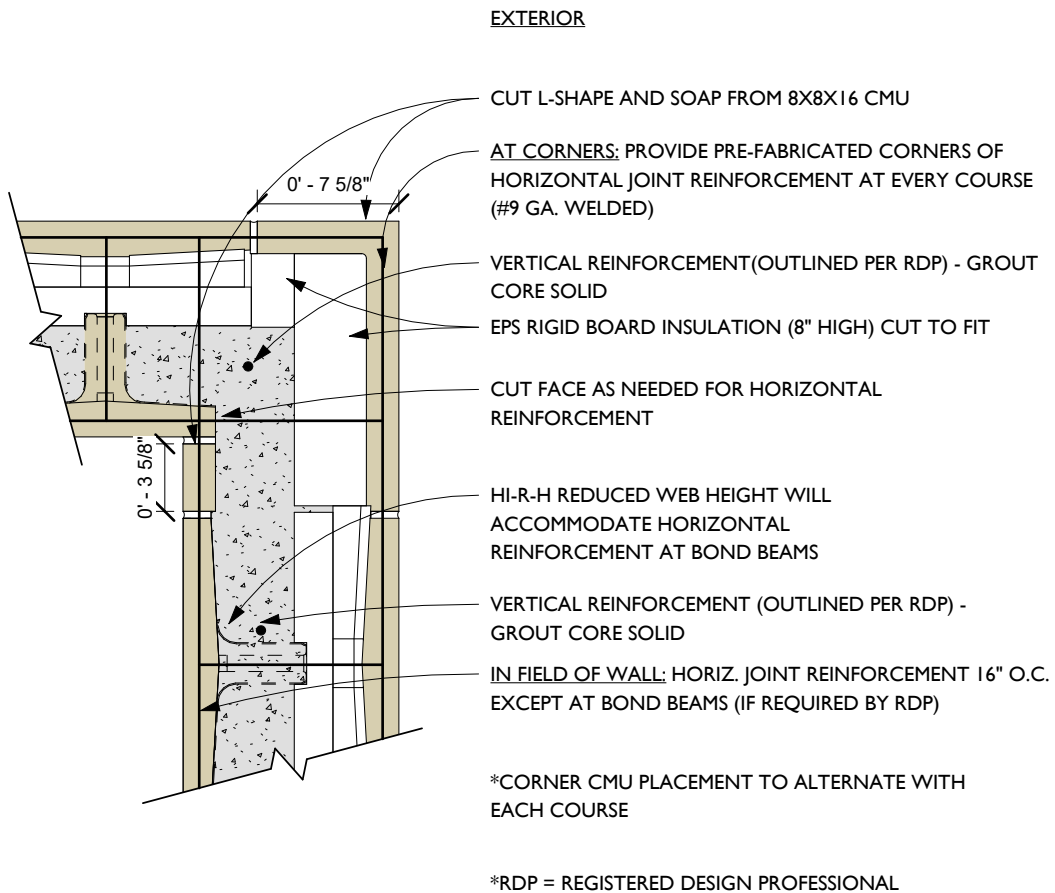

\*THIS DETAIL IS A STANDARD DETAIL. DESIGNERS SHOULD MAKE SITE SPECIFIC INVESTIGATIONS TO DETERMINE ACTUAL DESIGN REQUIREMENTS.

Detail 4-3122 - HI-R-H - Corner - 12X8X16 HI-R-H and CMU Unit Cuts

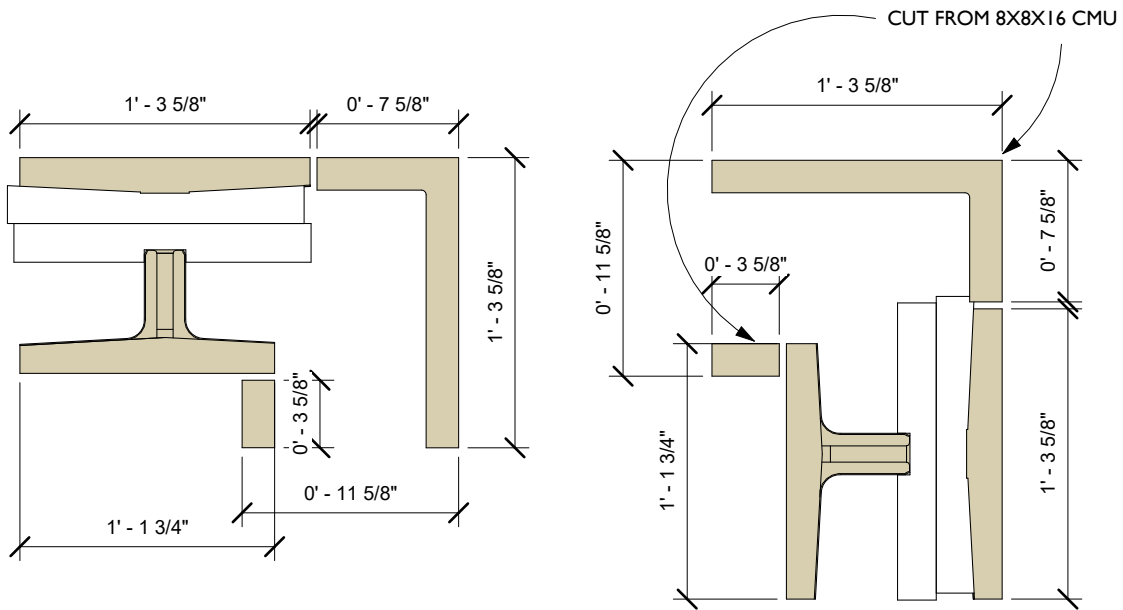

\*THIS DETAIL IS A STANDARD DETAIL. DESIGNERS SHOULD MAKE SITE SPECIFIC INVESTIGATIONS TO DETERMINE ACTUAL DESIGN REQUIREMENTS.

## Corners

### Detail 4-3123 - HI-R-H - Corner - 10X8X16 HI-R-H - First Course

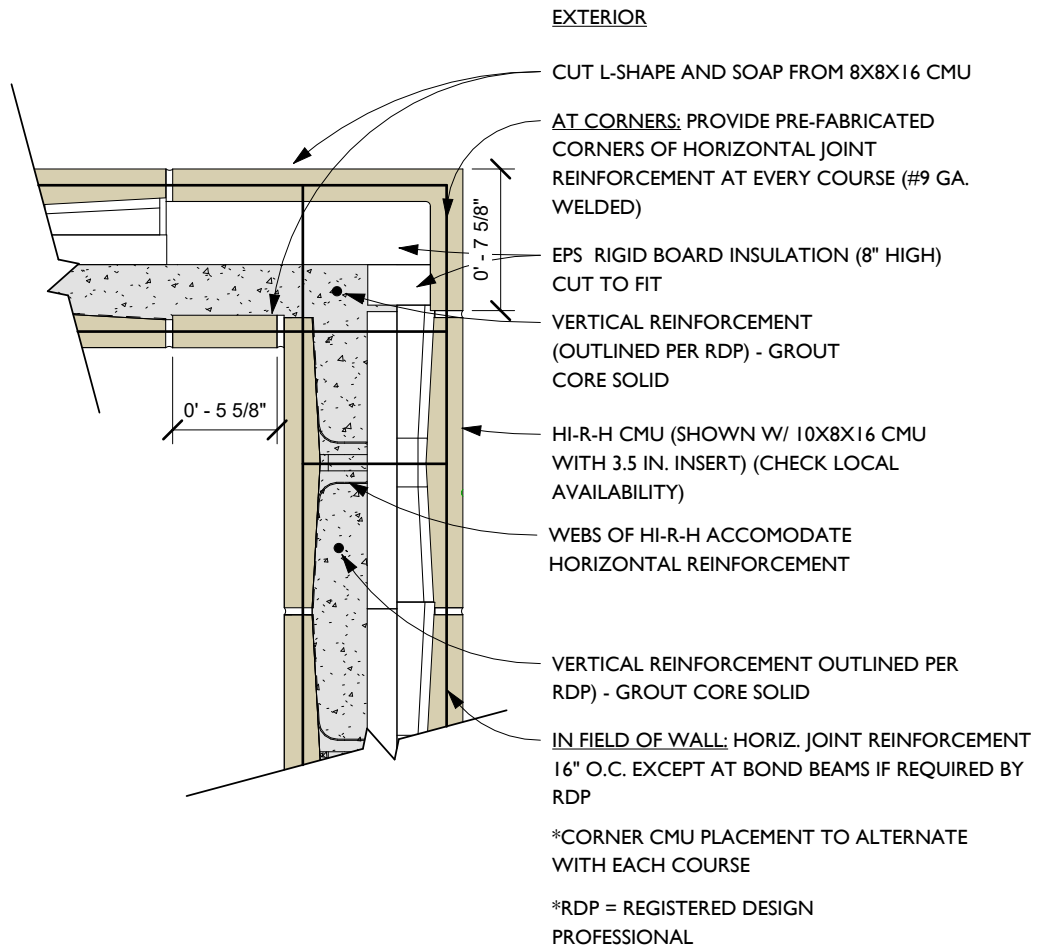

\*THIS DETAIL IS A STANDARD DETAIL. DESIGNERS SHOULD MAKE SITE SPECIFIC INVESTIGATIONS TO DETERMINE ACTUAL DESIGN REQUIREMENTS.

## Corners

### Detail 4-3124 - HI-R-H - Corner - 10X8X16 HI-R-H - Second Course

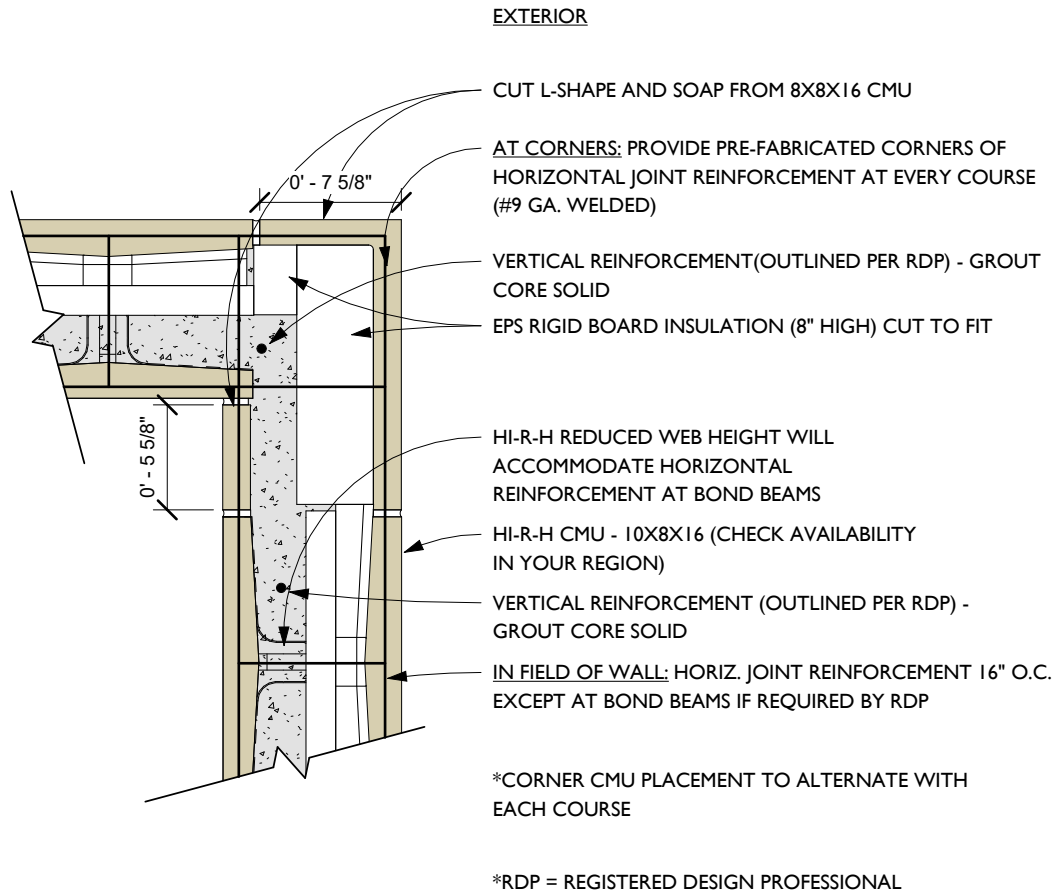

\*THIS DETAIL IS A STANDARD DETAIL. DESIGNERS SHOULD MAKE SITE SPECIFIC INVESTIGATIONS TO DETERMINE ACTUAL DESIGN REQUIREMENTS.

**Additional Notes – Corners:**

1. The use of an L-Shaped fitting and a soap cut from an 8X8X16 units has proven to be a popular choice for building corners. Another method uses the HI-R-H Sash/Jamb Unit cut for a corner. Of the two, the L-Shaped corner is generally preferred based on ease of installation.
2. Corners should be fully bonded and control joints placed no less than 2' 0" from corner.
3. The EPS corner pieces should be at least as thick as the HI-R insulation inserts to provide insulation as good or better than the HI-R-H units.
4. All details are available in Revit® and AutoCAD® – the numbering of the details in this manual corresponds to that used in the Revit® and AutoCAD® files.



**Corner Detail with L-Shaped Fitting Cut from 8x8x16 Jamb Unit with EPS Insulation Cut to Fit**

Detail 4-3200 – HI-R-H – Window Head and Lintel Using HI-R-H Unit

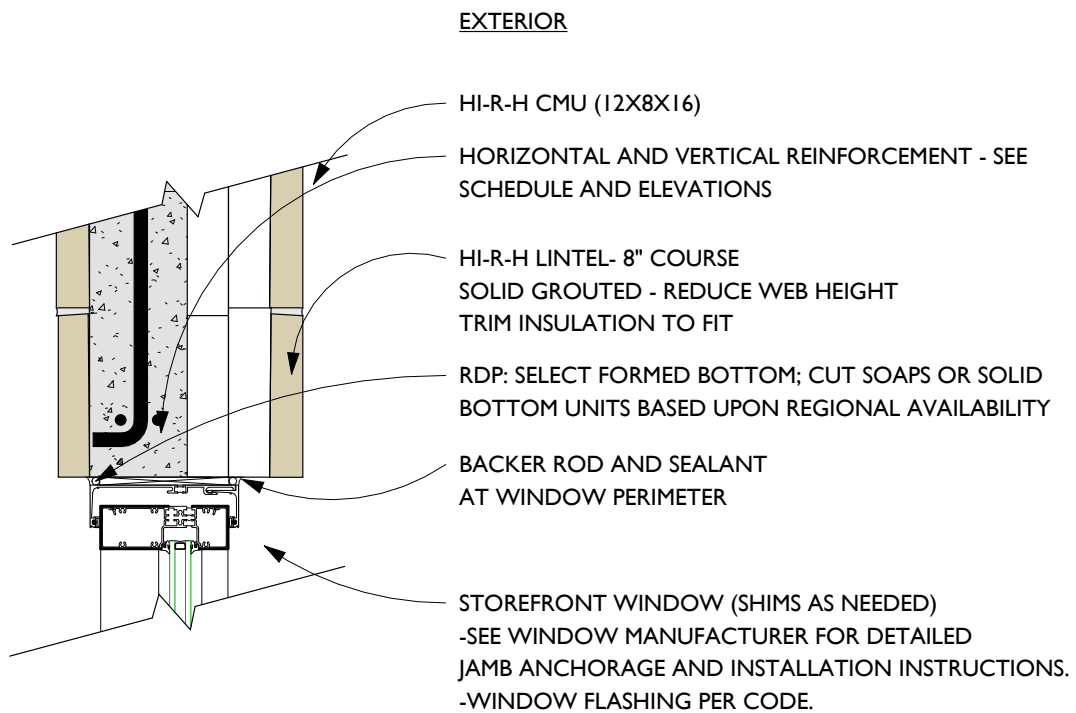

\*THIS DETAIL IS A STANDARD DETAIL. DESIGNERS SHOULD MAKE SITE SPECIFIC INVESTIGATIONS TO DETERMINE ACTUAL DESIGN REQUIREMENTS.

## Window Openings – Lintel

### Detail 4-3201 – HI-R-H – Window Head Using Inverted HI-R-H Unit

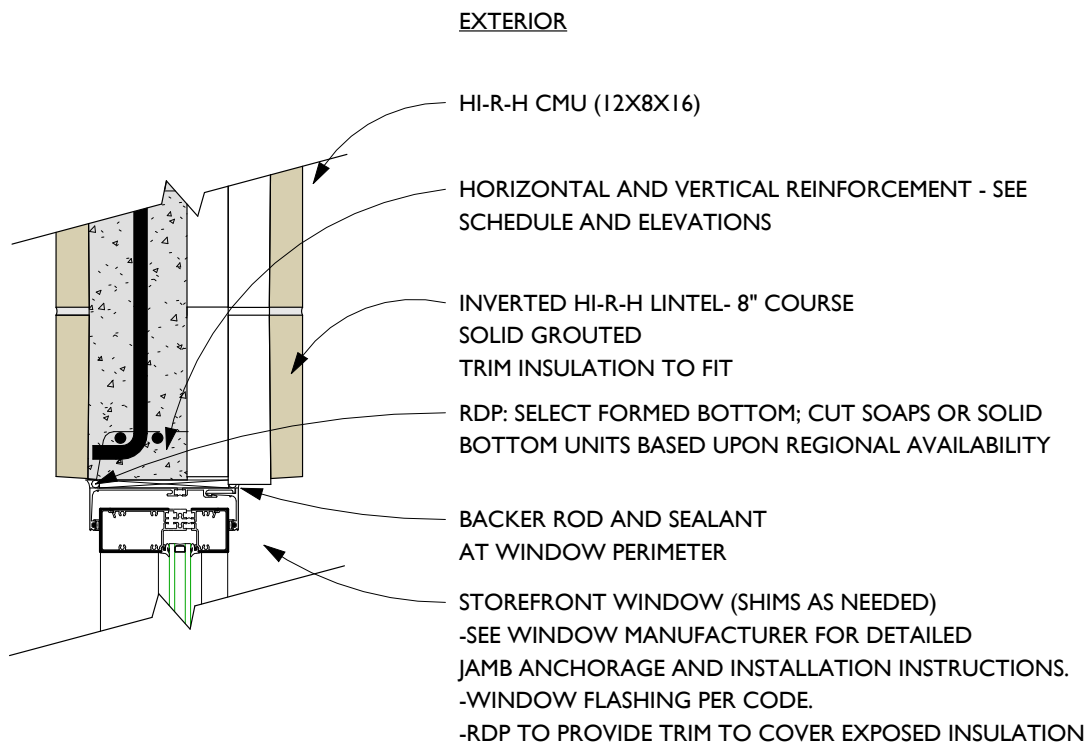

\*THIS DETAIL IS A STANDARD DETAIL. DESIGNERS SHOULD MAKE SITE SPECIFIC INVESTIGATIONS TO DETERMINE ACTUAL DESIGN REQUIREMENTS.

## Window Openings – Lintel

### Detail 4-3202- HI-R-H – Window Head and HI-R/HI-R-H Closed Bottom Lintel Unit

PLEASE CONFIRM  
LOCAL AVAILABILITY  
OF HI-R/HI-R-H CLOSED BOTTOM LINTEL  
PRIOR  
TO SPECIFYING

EXTERIOR

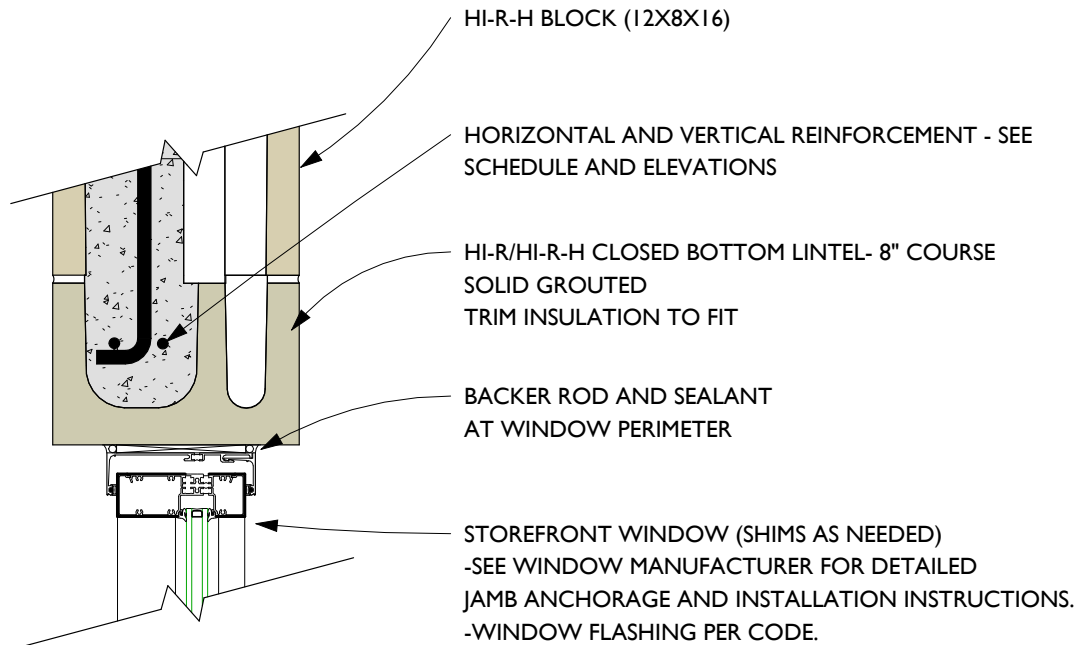

\*THIS DETAIL IS A STANDARD DETAIL. DESIGNERS SHOULD MAKE SITE SPECIFIC INVESTIGATIONS TO DETERMINE ACTUAL DESIGN REQUIREMENTS.

## Window Openings - Jamb

### Detail 4-3203 - HI-R-H - Window Jamb with CMU Jamb

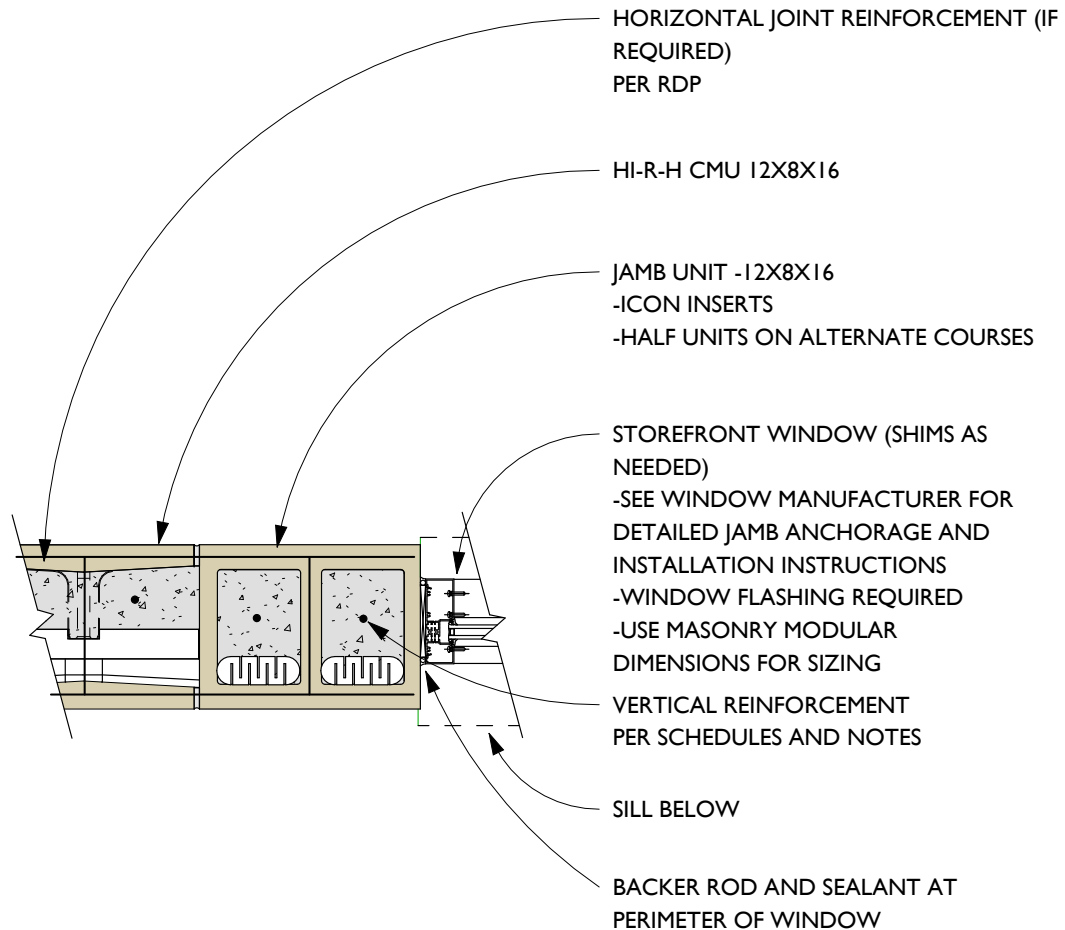

\*THIS DETAIL IS A STANDARD DETAIL. DESIGNERS SHOULD MAKE SITE SPECIFIC INVESTIGATIONS TO DETERMINE ACTUAL DESIGN REQUIREMENTS.

Detail 4-3204 - HI-R-H -Window Jamb with HI-R-H Sash/Jamb Unit

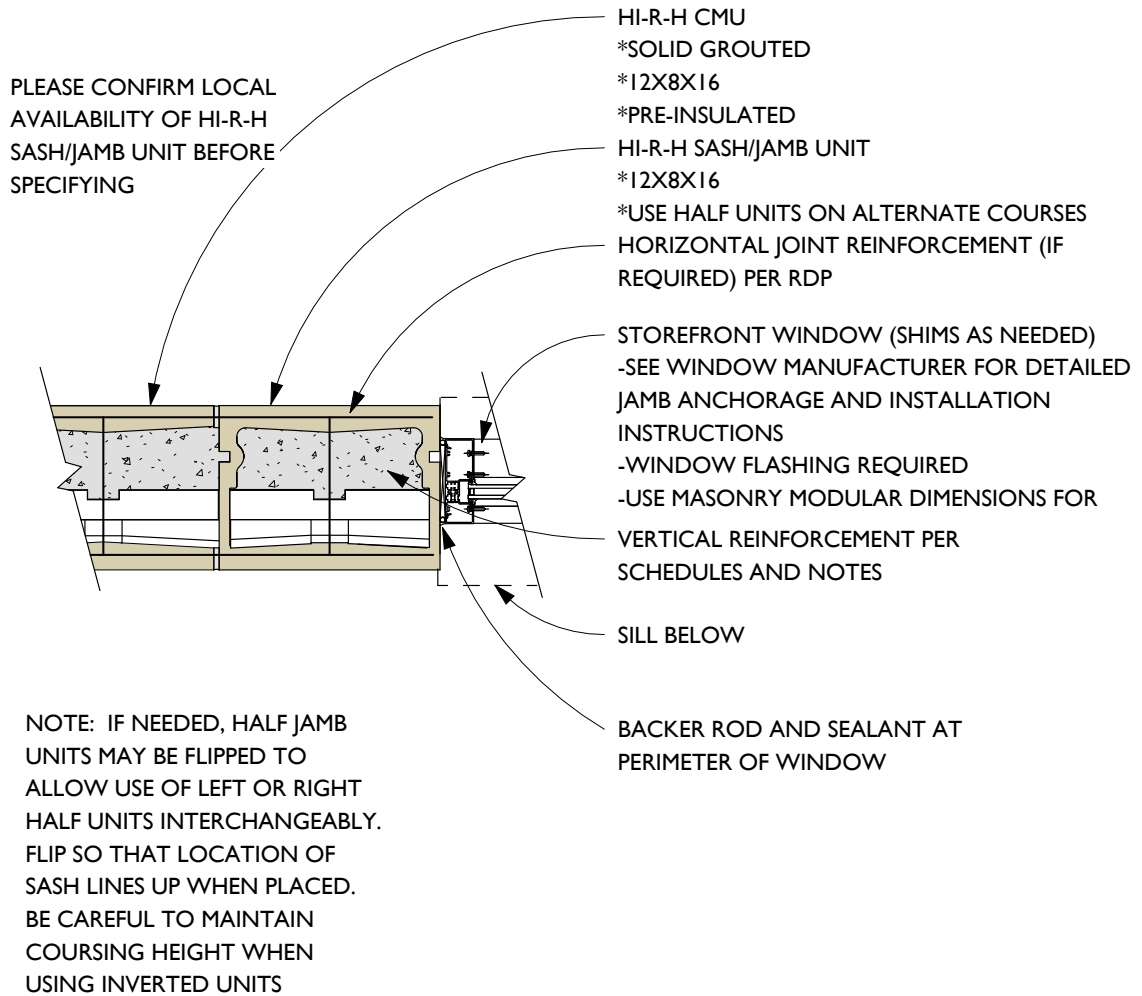

\*THIS DETAIL IS A STANDARD DETAIL. DESIGNERS SHOULD MAKE SITE SPECIFIC INVESTIGATIONS TO DETERMINE ACTUAL DESIGN REQUIREMENTS.

Detail 4-3205 - HI-R-H - Window Sill - 4" Sill Unit

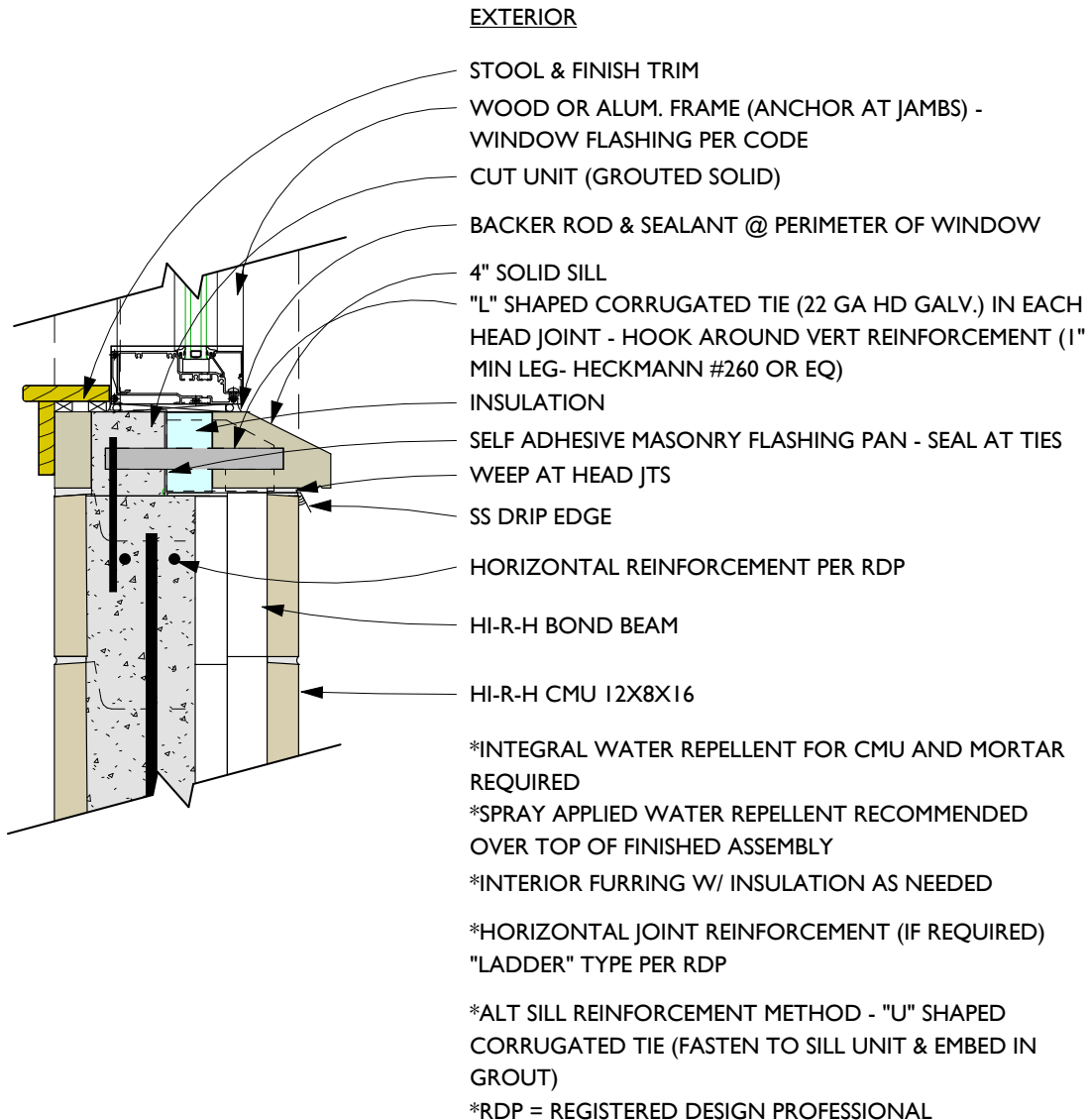

\*THIS DETAIL IS A STANDARD DETAIL. DESIGNERS SHOULD MAKE SITE SPECIFIC INVESTIGATIONS TO DETERMINE ACTUAL DESIGN REQUIREMENTS.

Detail 4-3206 - HI-R-H - Window Sill - 8" Sill Unit

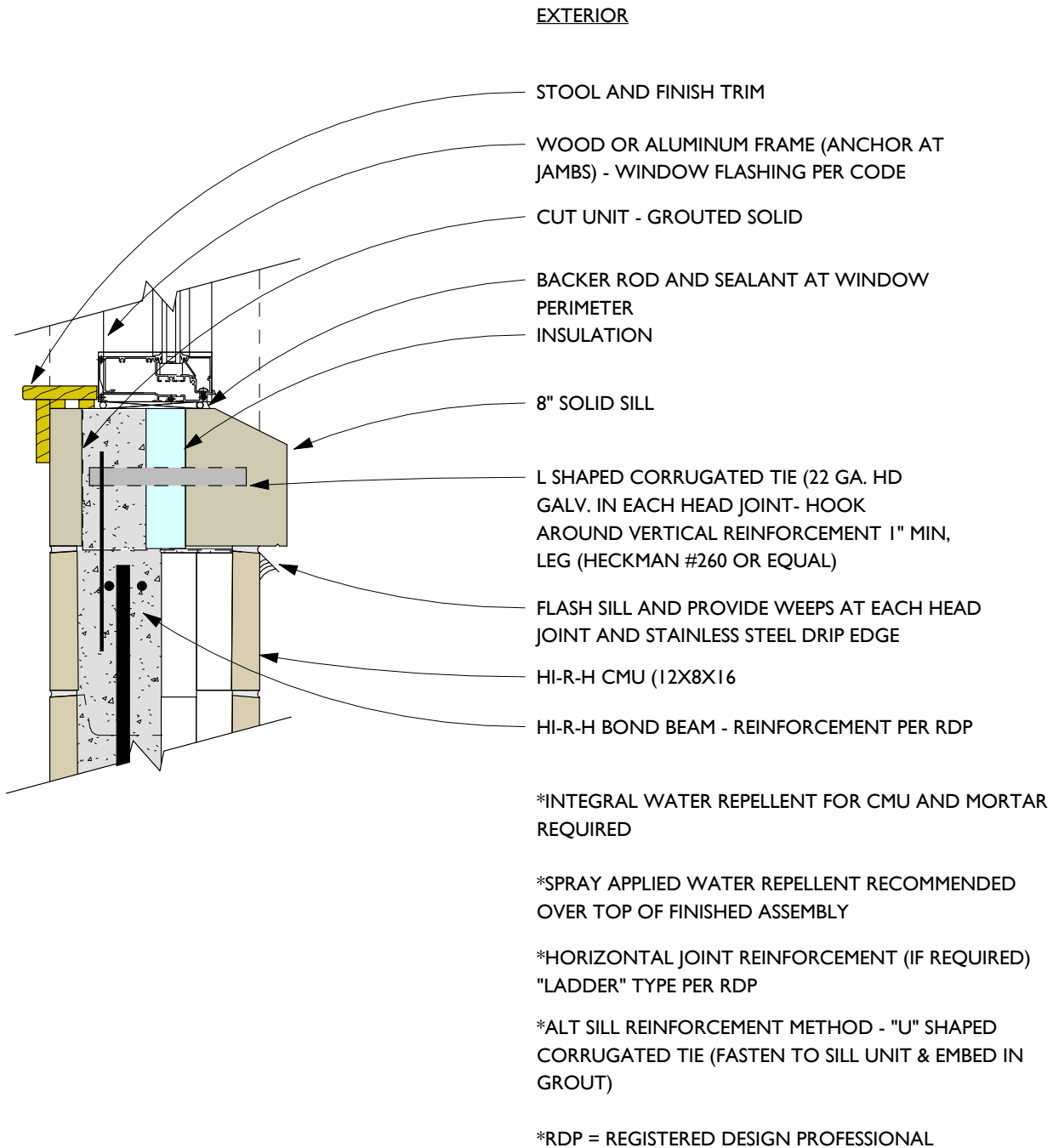

\*THIS DETAIL IS A STANDARD DETAIL. DESIGNERS SHOULD MAKE SITE SPECIFIC INVESTIGATIONS TO DETERMINE ACTUAL DESIGN REQUIREMENTS.

### Additional Notes – Window openings:

1. Lintels may either be formed from HI-R-H units (see notes regarding bond beams) or by using a specialized insulated HI-R/HI-R-H closed bottom lintel unit. This unit is only available in certain regions, so please check first before specifying. Lintels formed from HI-R-H units will require a surface treatment such as parging or finish trim since the lintel is open bottomed and the grout and inserts may be revealed without a finish treatment.
2. HI-R-H wall Jamb are typically formed using a CMU jamb unit with Icon® inserts or a specialized HI-R-H Sash/Jamb unit (check before specifying – regional availability only.) The thermal properties of the jamb should be considered when performing Energy Code compliance calculations.
3. The details show an insulated Window sill – choose rigid board insulation with sufficient thickness to meet requirements.
4. Always place and dimension openings with masonry modularity in mind – this will result in greatest cost efficiency.
5. All details are available in Revit® and AutoCAD® – the numbering of the details in this manual corresponds to that used in the Revit® and AutoCAD® files.



Lintel using HI-R-H Units shown under construction

Detail 4-3210 - HI-R-H - Door Head and Lintel with Inverted HI-R-H Unit

EXTERIOR

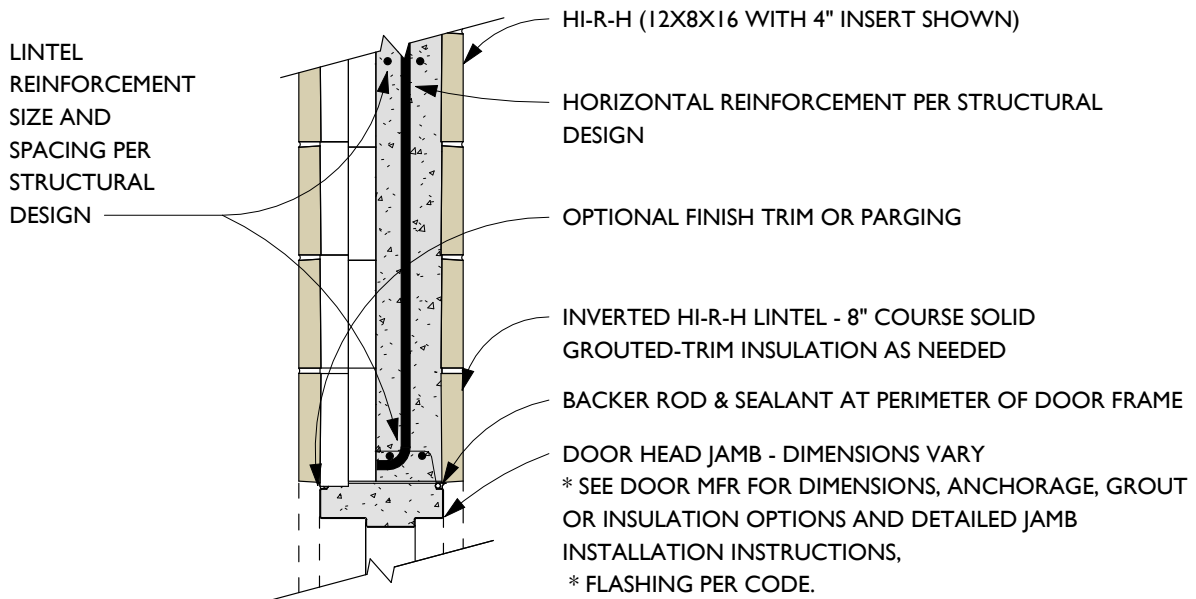

NOTE: PERSONNEL DOOR SHOWN - MODIFY FOR OVERHEAD DOOR SELECTED

\*THIS DETAIL IS A STANDARD DETAIL. DESIGNERS SHOULD MAKE SITE SPECIFIC INVESTIGATIONS TO DETERMINE ACTUAL DESIGN REQUIREMENTS.

## Door Openings - Lintel

### Detail 4-3211 - HI-R-H - Door Head and Lintel with HI-R/HI-R-H Closed Bottom Lintel Unit

PLEASE CONFIRM LOCAL AVAILABILITY  
OF HI-R/HI-R-H CLOSED BOTTOM LINTEL  
UNIT PRIOR TO SPECIFYING- NOT AVAILABLE  
IN ALL REGIONS

#### EXTERIOR

LINTEL  
REINFORCEMENT  
SIZE AND SPACING  
PER STRUCTURAL  
DESIGN

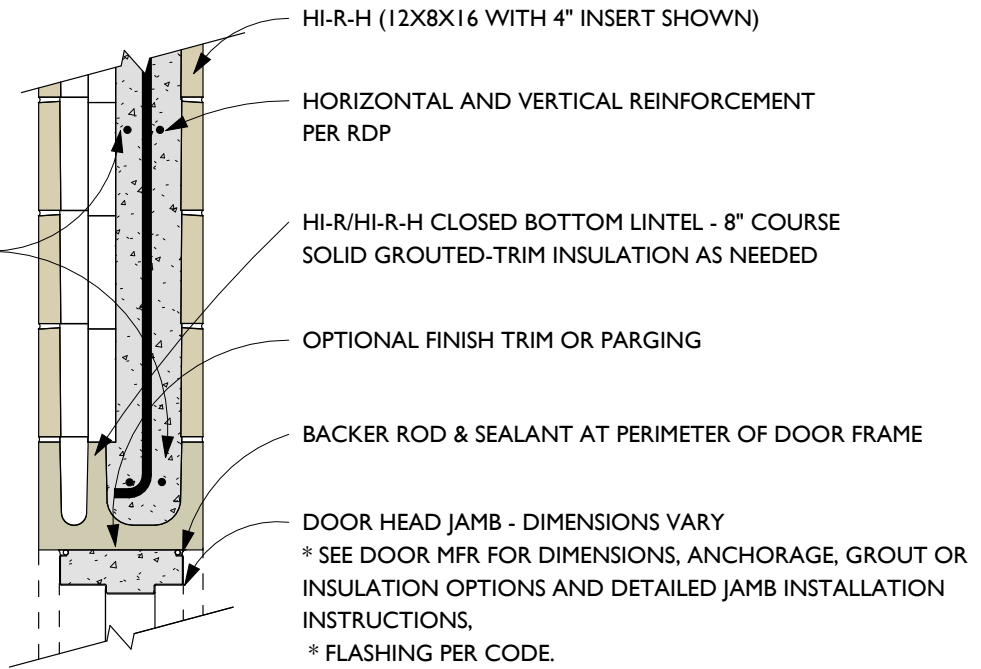

NOTE: PERSONNEL DOOR SHOWN - MODIFY FOR  
OVERHEAD DOOR SELECTED

\*THIS DETAIL IS A STANDARD DETAIL. DESIGNERS SHOULD MAKE SITE SPECIFIC INVESTIGATIONS TO DETERMINE ACTUAL DESIGN REQUIREMENTS.

Detail 4-3212 - HI-R-H - Door Jamb with HI-R-H Sash/Jamb Unit

PLEASE CONFIRM LOCAL AVAILABILITY OF HI-R-H SASH/JAMB UNIT BEFORE SPECIFYING

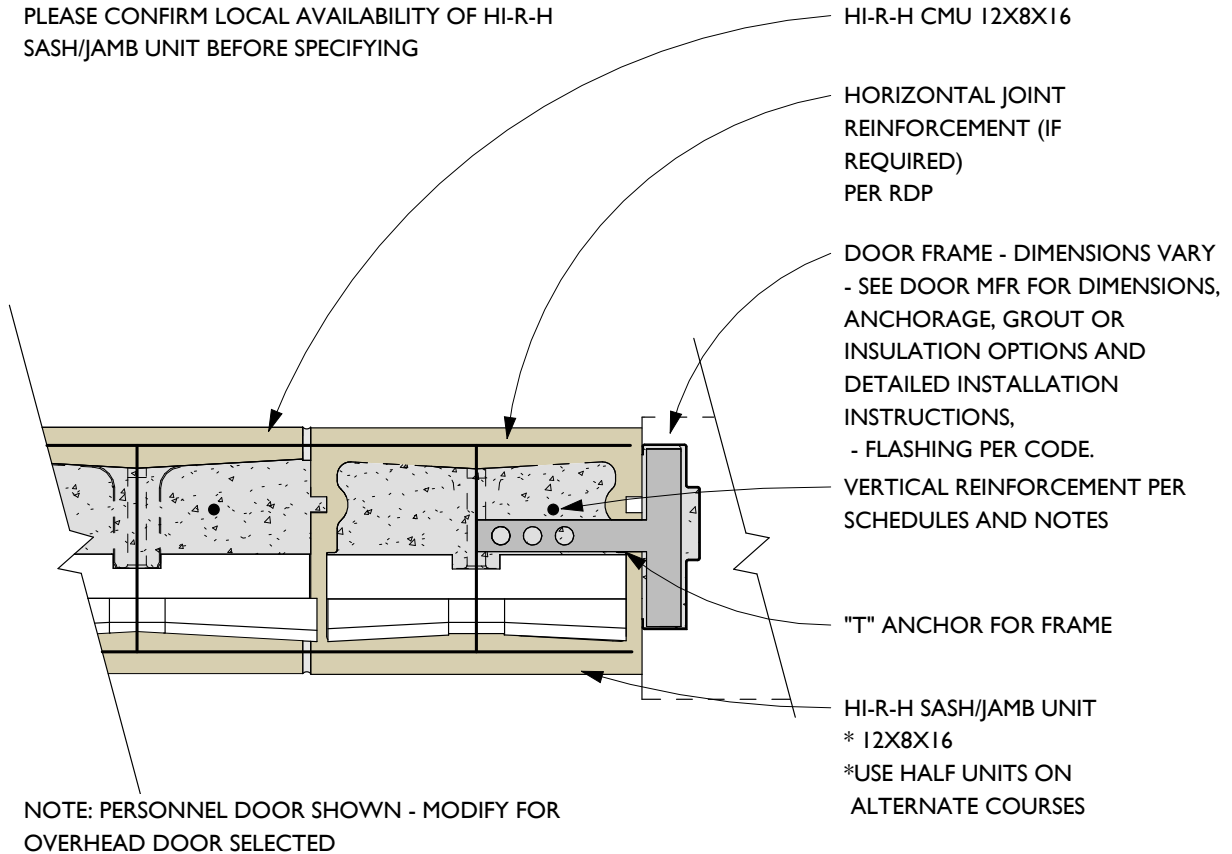

NOTE: HALF JAMB UNITS MAY BE FLIPPED TO ALLOW USE OF LEFT OR RIGHT HALF UNITS INTERCHANGEABLY. FLIP SO THAT LOCATION OF SASH LINES UP WHEN PLACED. BE CAREFUL TO MAINTAIN COURSE HEIGHT WHEN USING INVERTED UNITS

\*THIS DETAIL IS A STANDARD DETAIL. DESIGNERS SHOULD MAKE SITE SPECIFIC INVESTIGATIONS TO DETERMINE ACTUAL DESIGN REQUIREMENTS.

## Door Openings - Jamb

### Detail 4-3213 - HI-R-H - Door Jamb with CMU Jamb

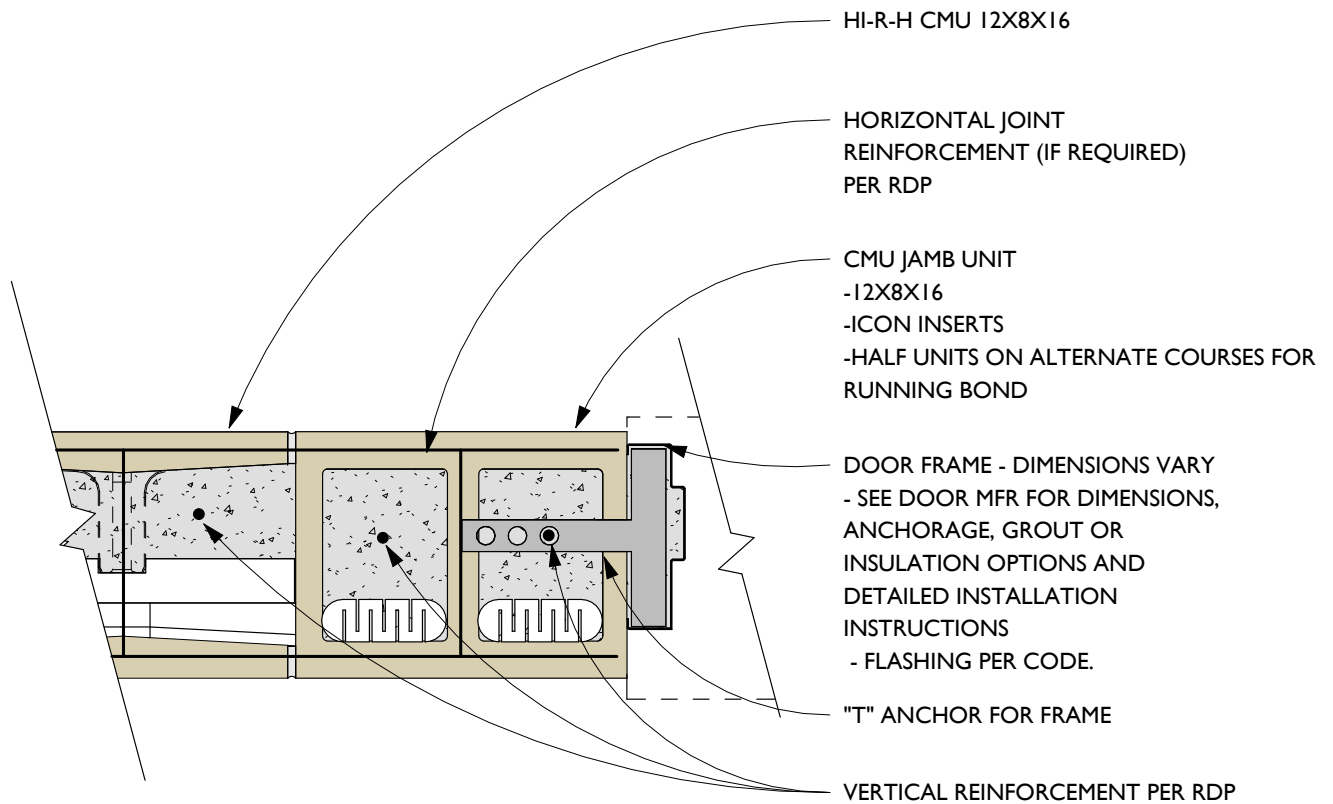

NOTE: PERSONNEL DOOR SHOWN - MODIFY FOR OVERHEAD DOOR SELECTED

\*THIS DETAIL IS A STANDARD DETAIL. DESIGNERS SHOULD MAKE SITE SPECIFIC INVESTIGATIONS TO DETERMINE ACTUAL DESIGN REQUIREMENTS.

**Additional Notes – Door openings:**

1. See notes to Window openings.
2. All details are available in Revit® and AutoCAD® – the numbering of the details in this manual corresponds to that used in the Revit® and AutoCAD® files.

Detail 4-3300 - HI-R-H - Precast Plank Bearing Wall

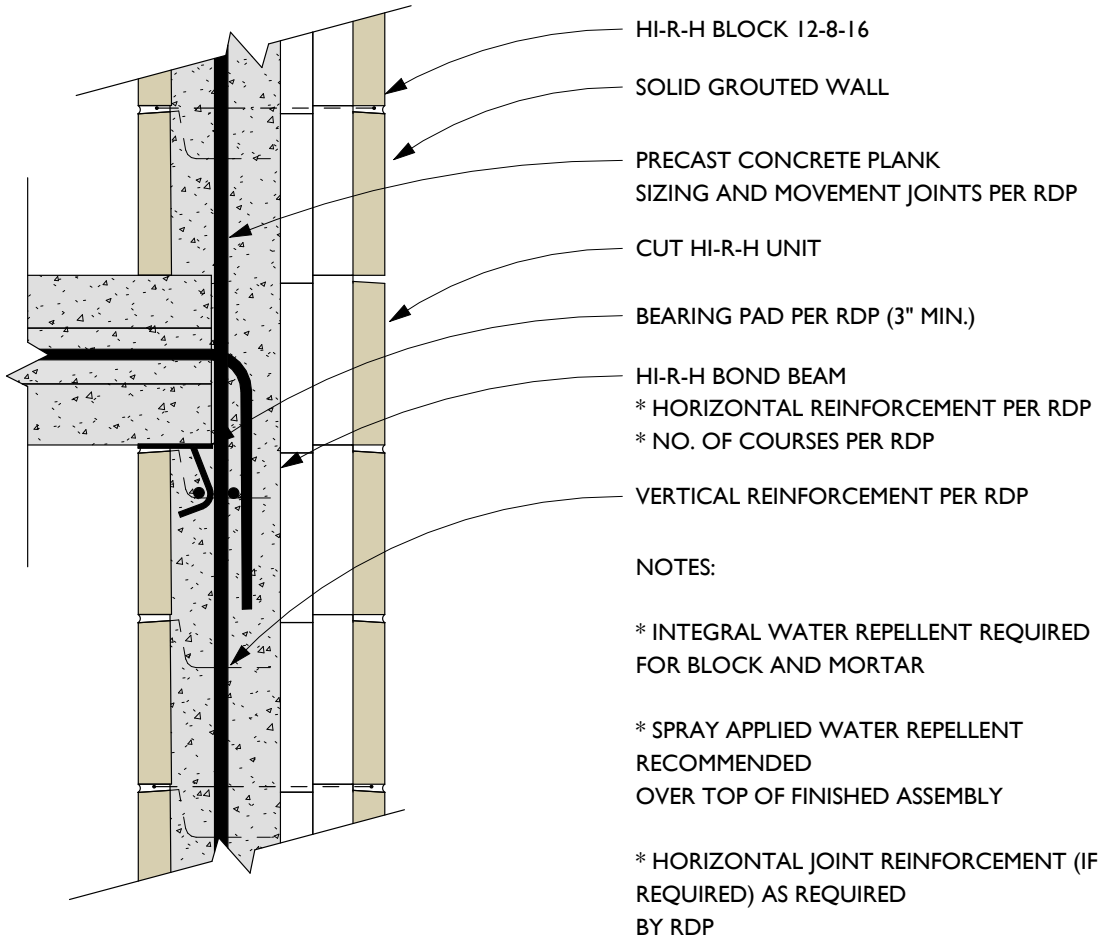

\*THIS DETAIL IS A STANDARD DETAIL. DESIGNERS SHOULD MAKE SITE SPECIFIC INVESTIGATIONS TO DETERMINE ACTUAL DESIGN REQUIREMENTS.

Detail 4-3301 - HI-R-H - Precast Plank Non-Bearing Wall

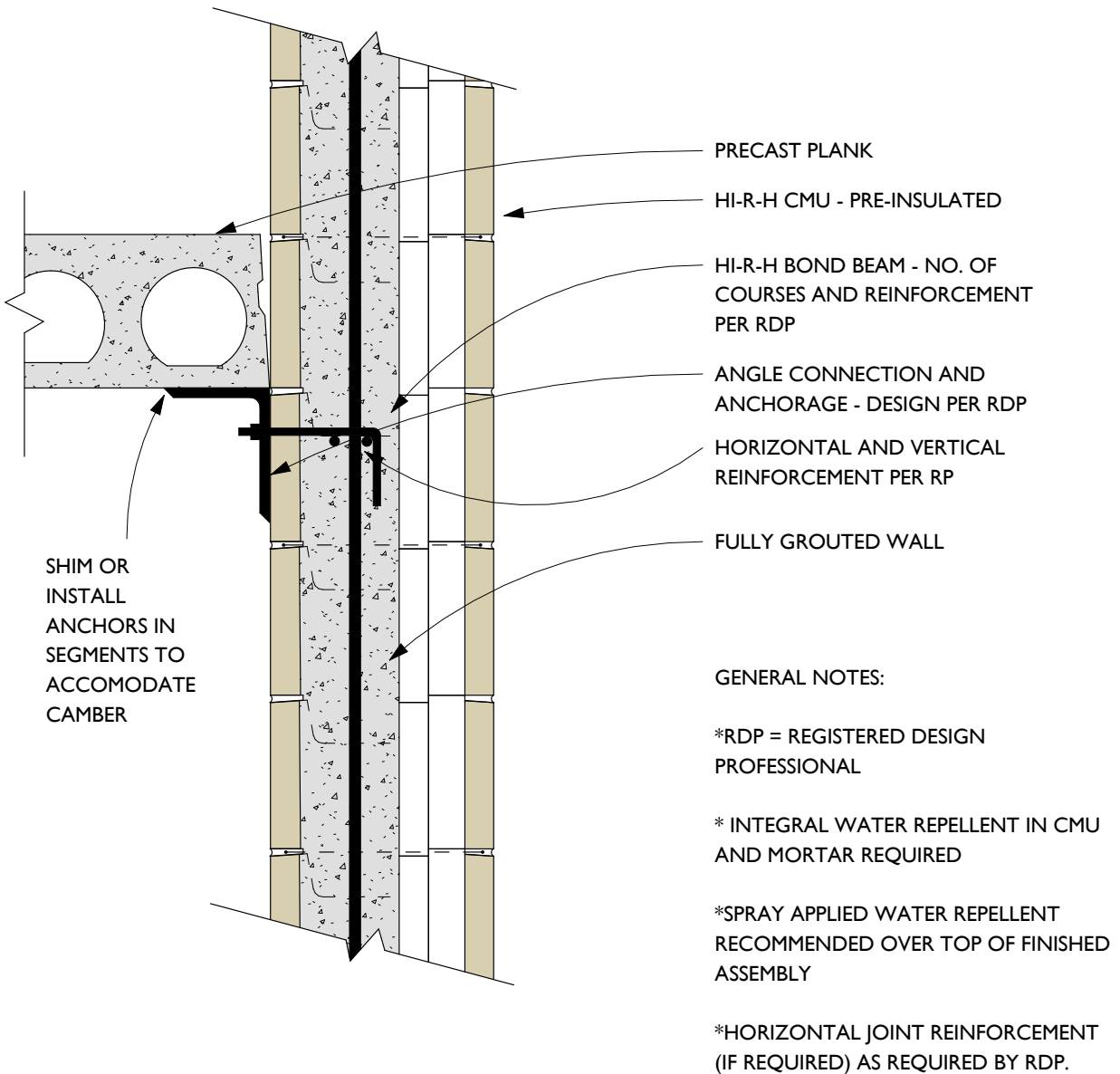

\*THIS DETAIL IS A STANDARD DETAIL. DESIGNERS SHOULD MAKE SITE SPECIFIC INVESTIGATIONS TO DETERMINE ACTUAL DESIGN REQUIREMENTS.

**Additional Notes – Planks:**

1. See notes to regarding bond beams.
2. All details are available in Revit® and AutoCAD® – the numbering of the details in this manual corresponds to that used in the Revit® and AutoCAD® files.

## Roof Joist and Parapet

### Detail 4-3310 - HI-R-H - Roof and Parapet - Bearing Wall

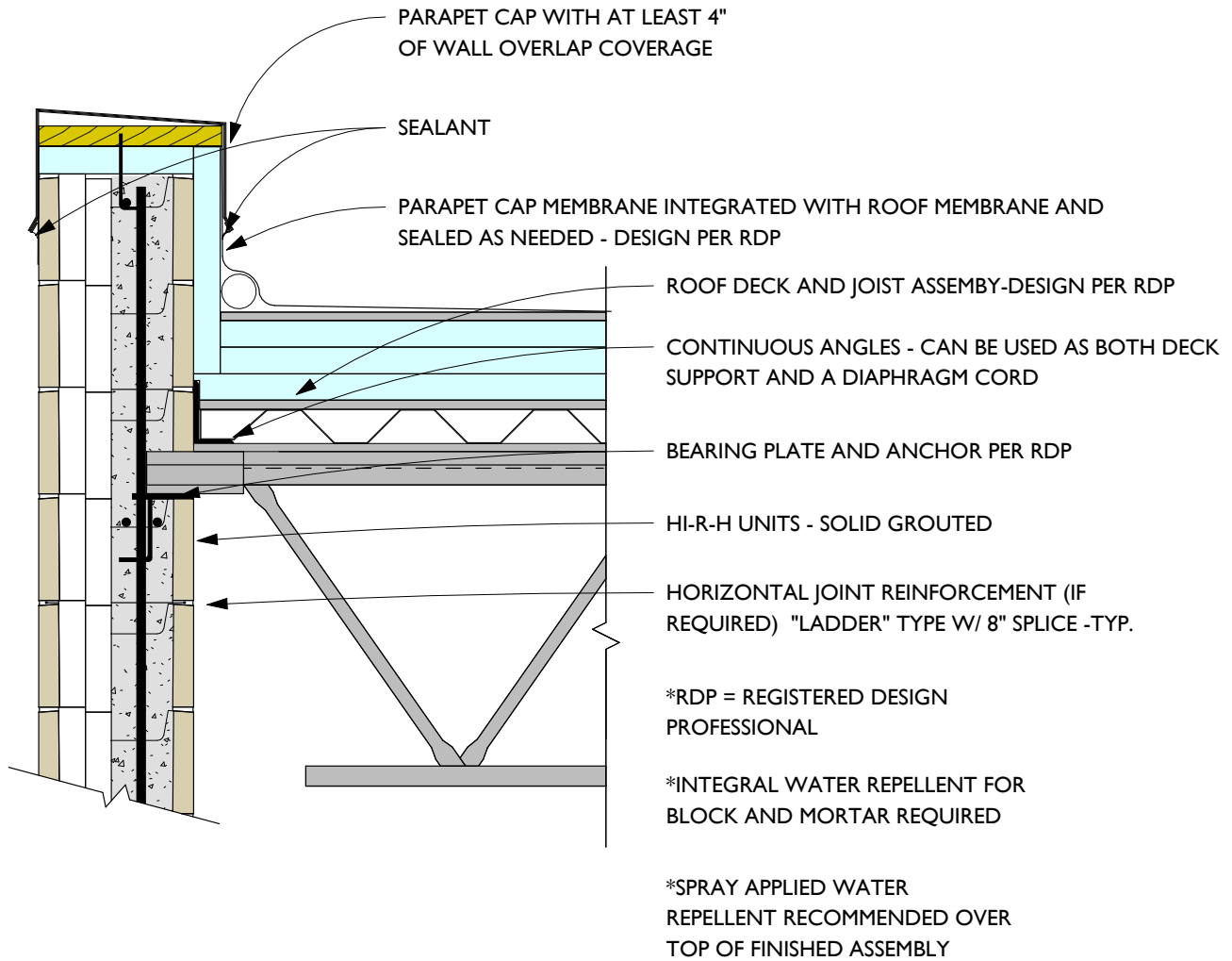

\*THIS DETAIL IS A STANDARD DETAIL. DESIGNERS SHOULD MAKE SITE SPECIFIC INVESTIGATIONS TO DETERMINE ACTUAL DESIGN REQUIREMENTS.

## Roof Joist and Parapet

### Detail 4-3311 - HI-R-H - Roof and Parapet - Non-Bearing Wall

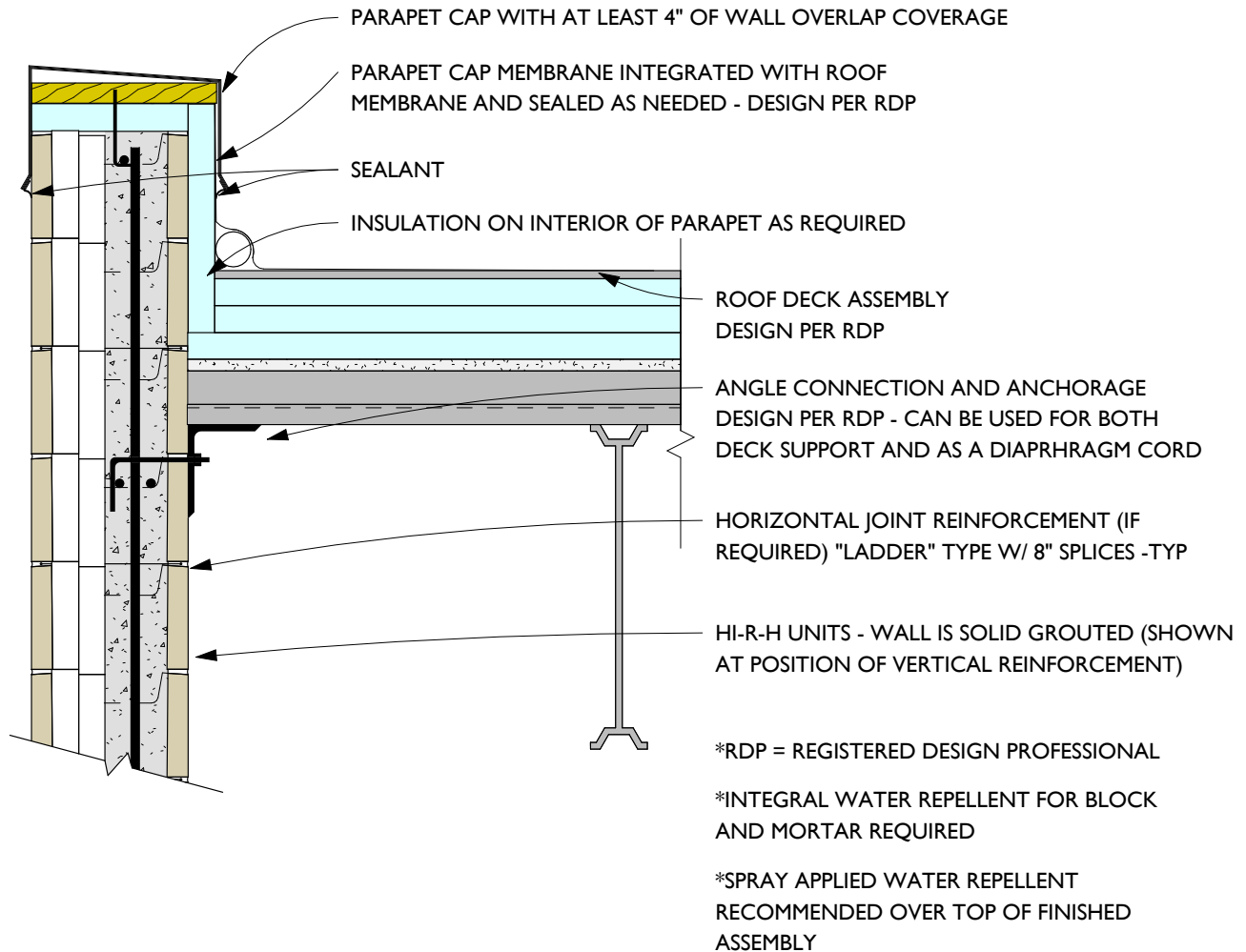

\*THIS DETAIL IS A STANDARD DETAIL. DESIGNERS SHOULD MAKE SITE SPECIFIC INVESTIGATIONS TO DETERMINE ACTUAL DESIGN REQUIREMENTS.

**Additional Notes – Roof Joist and Parapet:**

1. See notes regarding bond beams.
2. Insulating the inward face of the parapet provides protection against thermal bridging at that location.
3. All details are available in Revit® and AutoCAD® – the numbering of the details in this manual corresponds to that used in the Revit® and AutoCAD® files.

Detail 4-3320 - HI-R-H - CMU Pilaster Plan View

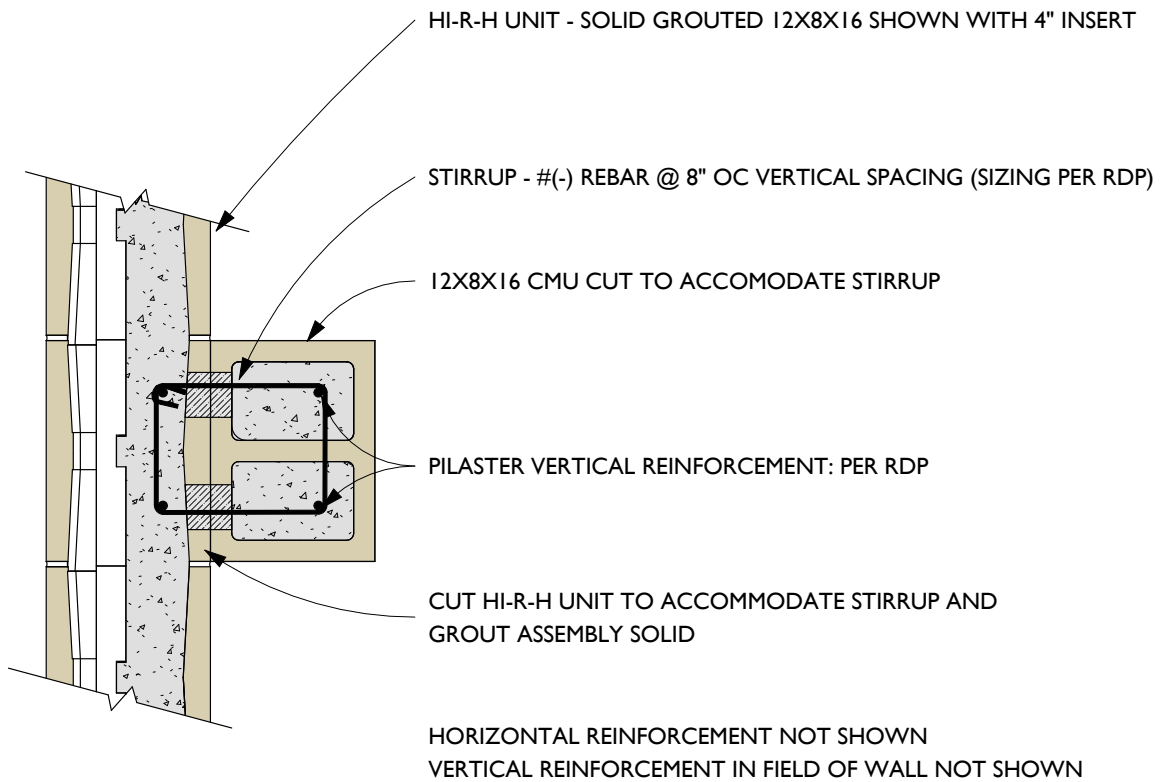

EXAMPLE ONLY; NOT FOR CONSTRUCTION  
REINFORCEMENT REQUIREMENTS VARY

\*THIS DETAIL IS A STANDARD DETAIL. DESIGNERS SHOULD MAKE SITE SPECIFIC INVESTIGATIONS TO DETERMINE ACTUAL DESIGN REQUIREMENTS.

Detail 4-3321 - HI-R-H - CMU Pilaster - Section View

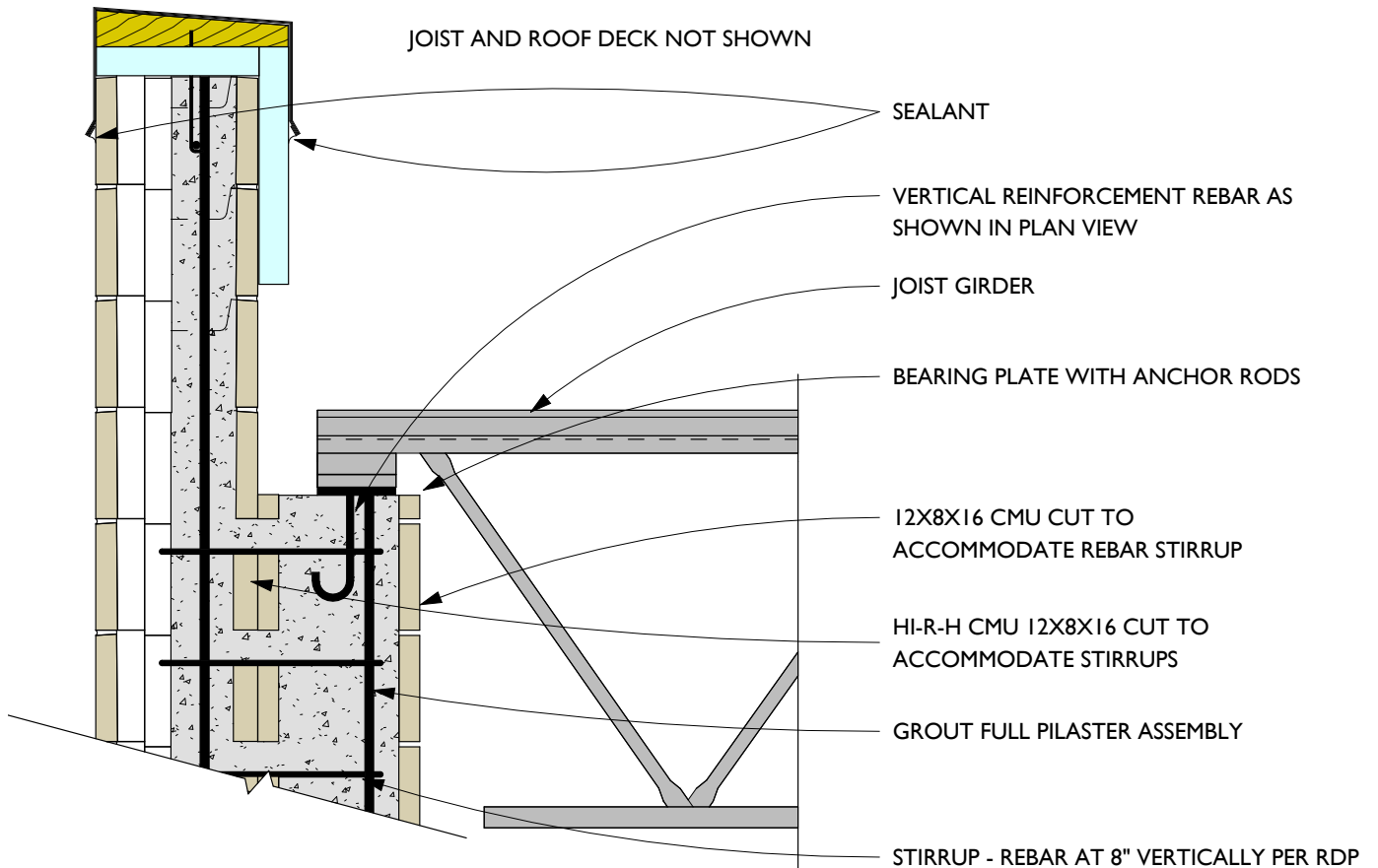

EXAMPLE ONLY; NOT FOR CONSTRUCTION -  
REINFORCEMENT REQUIREMENTS VARY

\*THIS DETAIL IS A STANDARD DETAIL. DESIGNERS SHOULD MAKE SITE SPECIFIC INVESTIGATIONS TO DETERMINE ACTUAL DESIGN REQUIREMENTS.

**Additional Notes – Pilaster:**

1. See notes regarding bond beams.
2. Pilasters are often a cost-effective addition to meet structural requirements for the building roof.
3. Insulating the inward face of the parapet provides protection against thermal bridging at that location.
4. All details are available in Revit® and AutoCAD® – the numbering of the details in this manual corresponds to that used in the Revit® and AutoCAD® files.



---

## HI-R Half High Construction Details

---

# HI-R® Half High

The **HI-R HALF HIGH** Masonry Unit has been designed to provide reduced thermal bridging. The system gives the designer choices for a wall system capable of achieving higher thermal R-values than conventional masonry and Code compliant designs for load resistance purposes. HI-R Half High units may be used in both fully and partially grouted wall assemblies with no need to remove the insulation inserts so thermal performance is uncompromised. The **Spec-Brik HI-R Wall System** adds Spec-Brik color blends to the HI-R Half High unit configuration. This allows the construction of walls that offer the look of brick while providing superior thermal performance to assist in meeting prevailing Codes and Standards.

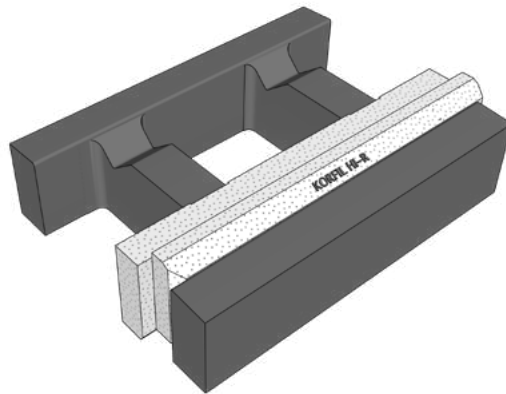

**HI-R HALF HIGH**

## Key Features

**Enhanced Thermal Protection.** HI-R Half High units provide the same level of thermal performance as full height Spec-Thermal HI-R units in terms of thermal mass and insulation, providing a considerable advantage over conventional masonry and other wall systems.

**Beauty.** Spec-Brik HI-R units are offered in dimensions and blended colors that provide the look of brick at affordable costs.

**Durability and Resilience.** Spec-Brik HI-R offers the durability of double exposed masonry to protect the insulation inserts and provide a long-lasting and resilient building envelope.

**Ease of Installation.** HI-R Half High is installed using standard methods. The units come pre-assembled with the insulation inserts. Construction of standard masonry details is straightforward. Units may be saw cut to reduce web height for use as knock out bond beam units to accommodate reinforcement.

**Consistent Insulation.** HI-R Half High units can be partially or fully grouted without removing the insulation inserts, so that thermal performance is maintained through the wall structure.

**Moisture Control.** Multiple measures resist moisture penetration. HI-R Half High units and the mortar can be specified to contain integral water repellent. A Post-Applied clear breathable water repellent is applied to the wall system. The interlocking insulation inserts provide increased resistance to wind driven rain. When partially grouted, drainage is provided in the cores to the flashing and weep systems. When fully grouted, no flashing or weeps are necessary except adjacent to certain openings in the wall.



# Wall System: 12×4×16 HI-R Half High

## Summary of System Component Options:

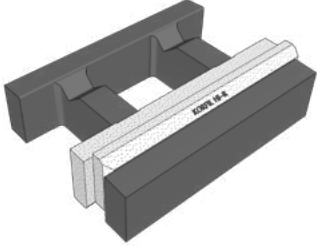
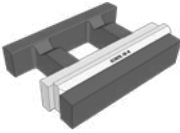
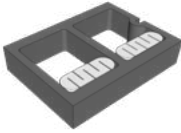
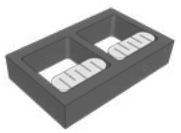
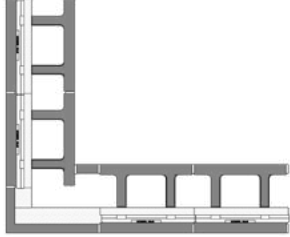
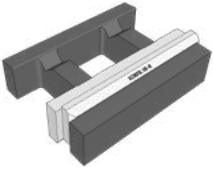
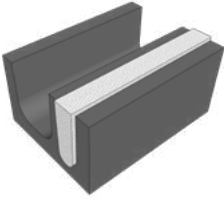
	<p>Main wall units: HI-R Half High 12×4×16 Stretcher Unit Insulation is 2.5" thick</p> <p>Bond beams: HI-R Half High 12×4×16 unit KOBB</p>			
<p>Control Joints: HI-R Michigan Style Control Joint or CMU Sash Unit</p>		 <p>HI-R Half High Unit</p>	 <p>CMU Sash Unit with Icon® Inserts</p>	 <p>CMU Jamb Unit with Icon® Inserts</p>
<p>Jambs: CMU Jamb Unit**</p>				
<p>Corners: L-Shaped CMU fitting with EPS Insulation</p>		 		
<p>Lintels: HI-R Half High units or HI-R 12×8×16 Insulated Lintel*</p>				

\* Availability may be limited in some regions. Please confirm local availability before specifying.

Detail 4-4000 HI-R Half High - CMU Foundation

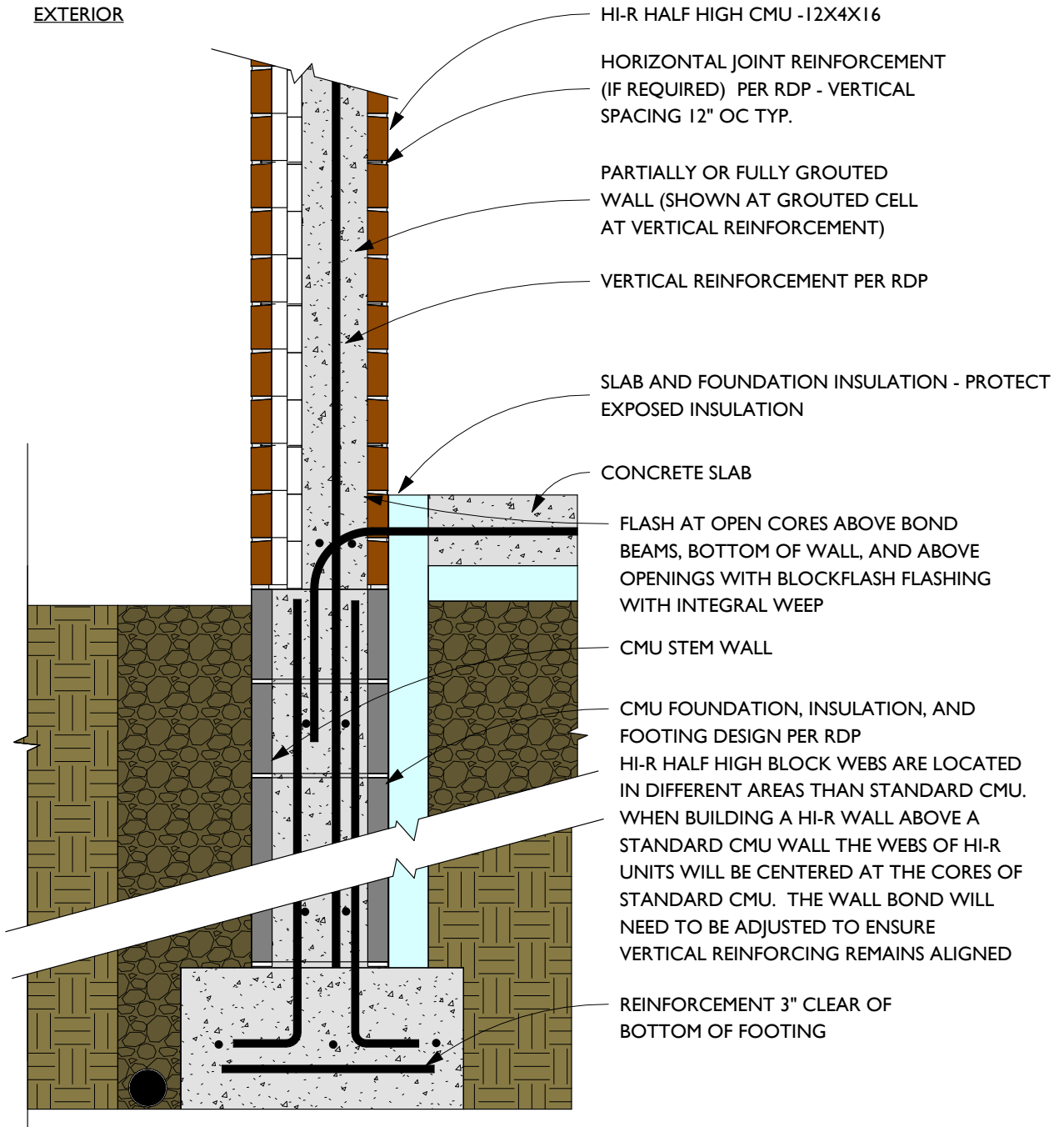

\*THIS DETAIL IS A STANDARD DETAIL. DESIGNERS SHOULD MAKE SITE SPECIFIC INVESTIGATIONS TO DETERMINE ACTUAL DESIGN REQUIREMENTS.

Detail 4-4001 HI-R Half High - Foundation - Concrete

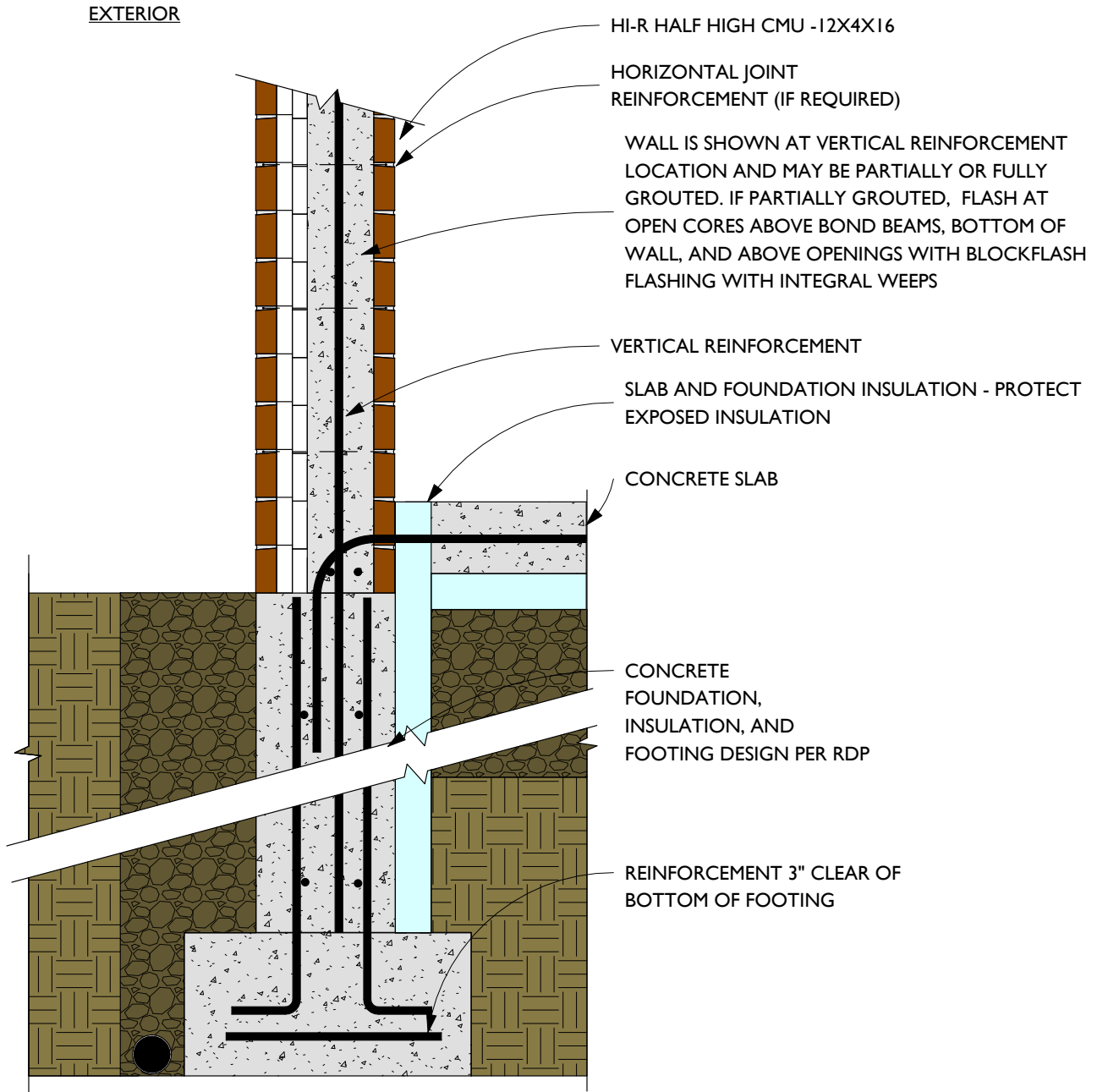

\*THIS DETAIL IS A STANDARD DETAIL. DESIGNERS SHOULD MAKE SITE SPECIFIC INVESTIGATIONS TO DETERMINE ACTUAL DESIGN REQUIREMENTS.

**Detail 4-4002 HI-R Half High – Foundation Fully Grouted HI-R Stem Wall**

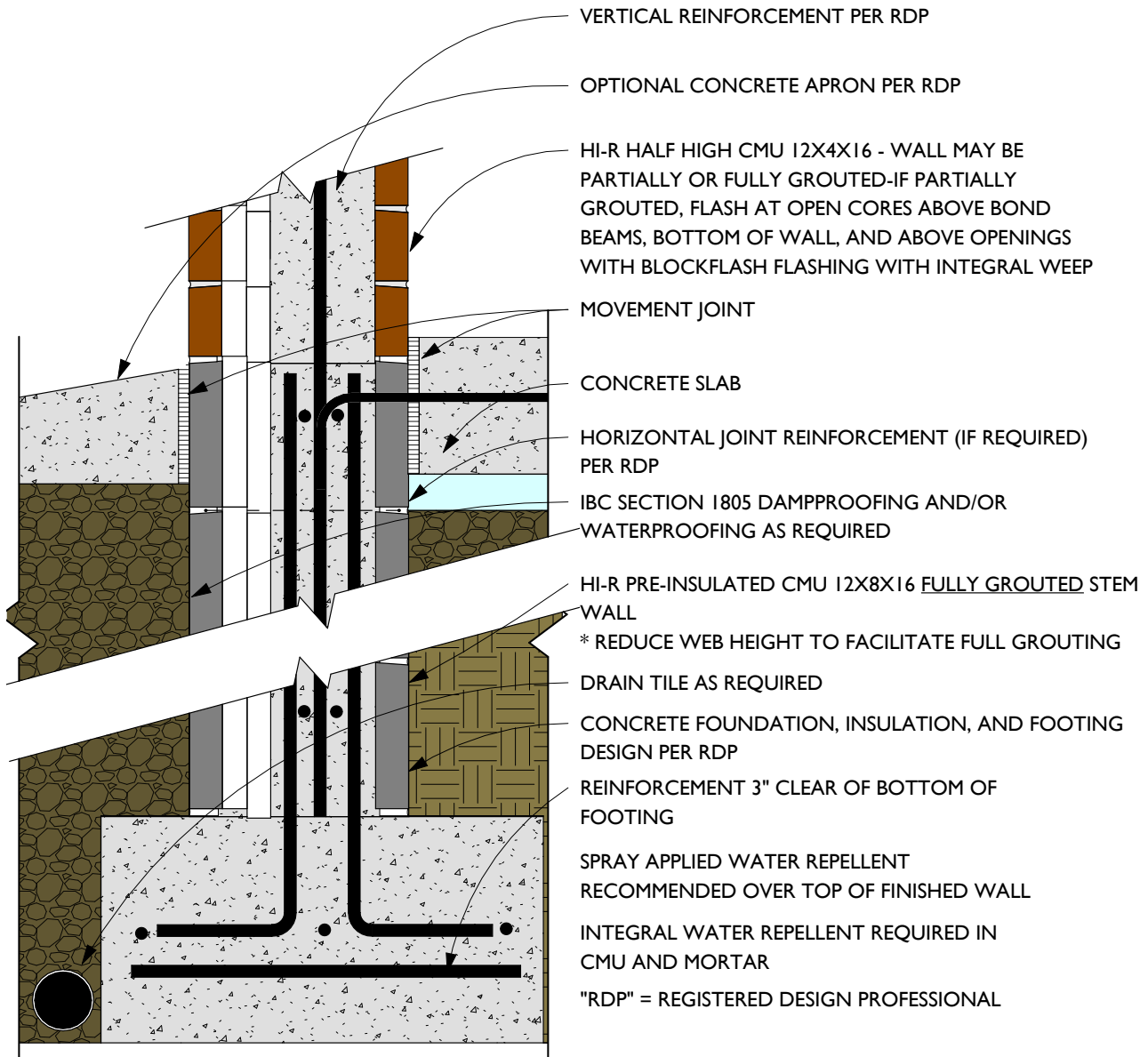

\*THIS DETAIL IS A STANDARD DETAIL. DESIGNERS SHOULD MAKE SITE SPECIFIC INVESTIGATIONS TO DETERMINE ACTUAL DESIGN REQUIREMENTS.

## Foundations

1. In this manual, we present three choices for foundation wall construction: poured in place concrete, CMU, and pre-insulated CMU – Spec-Thermal® HI-R or HI-R-H. Each will meet structural requirements when properly designed. Both the concrete and traditional CMU footing/stem/crawl space/foundations will typically require insulation placement either to the exterior or interior (or both) of the foundation wall. The HI-R foundation wall is fully grouted and pre-insulated with integral insulation in the unit. Consult with Structural and/or Geo-technical Engineers for appropriate below-grade insulation material and placement.
2. Check local Code for slab insulation requirements – if the slab is on grade, address the thermal bridge at the slab by either placing interior or exterior insulation at this location. Insulation placed at the exterior will typically require some form of hardened protective covering. For insulation requirements see e.g., IECC/IRC Section R402.2.10/N1102.2.10 Slab-On-Grade Floors.
3. The use of pre-insulated block for the foundation and above grade walls provides a simple way to meet insulation requirements for both types of walls. It also has structural benefits as the foundation wall is fully supported directly by the engineered soils. Full grout should be used for the foundation wall. The insulation is protected integral insulation which eliminates damage concerns.
4. Generally a damp-check needs be placed above the top of the damp-proofing or waterproofing for foundation walls, basement walls, or foundations. For below-grade masonry basement walls an additional damp check at the masonry starting course and above the damp-proofing or waterproofing for slabs and floors will further control moisture. An above-grade masonry course with flashing also performs as a damp-check.
5. A tapered (30° from horizontal) 6" zone of free-draining gravel extending from the height of the finished floor to the top of the engineered soil may be substituted for the concrete apron shown.
6. HI-R Half High single wythe walls above grade may be partially grouted or fully grouted. If partial grout is used, flashing and weeps should be placed at all interruptions in the drainage plane in the wall – typically these will occur at bond beams, lintels and the bottom of the wall.
7. There are a variety of time-proven methods to provide flashing. For single wythe walls, we suggest the use of the pan flashing system Blockflash® over traditional through wall flashing methods because it can be placed without interrupting the mortar bond in the bed joint between the units where it is placed.
8. To provide robust protection of above grade single wythe walls from moisture penetration, we recommend integral water repellent (IWR) be used in both the block and mortar. The IWR in the block and mortar need to be chemically compatible (check with block manufacturer for recommendations). Some exceptions to using IWR may apply such as for California masonry core testing. To provide additional protection, we recommend use of a post-applied breathable water repellent over the finished wall after cleaning has been completed and approved and the walls are completely dry.
9. If the zone near the above-grade wall or foundation wall is to be landscaped, do not place plant life, roots, irrigation, fertilizers or other chemicals within 3 feet of the above-grade wall or foundation wall. Isolate the above-grade wall, foundation wall, footing, foundation, and slab from such elements.
10. All details are available in Revit® and AutoCAD® – the numbering of the details in this manual corresponds to that used in the Revit® and AutoCAD® files.

Detail 4-4100 - HI-R Half High - Michigan Style Control Joint - Section View

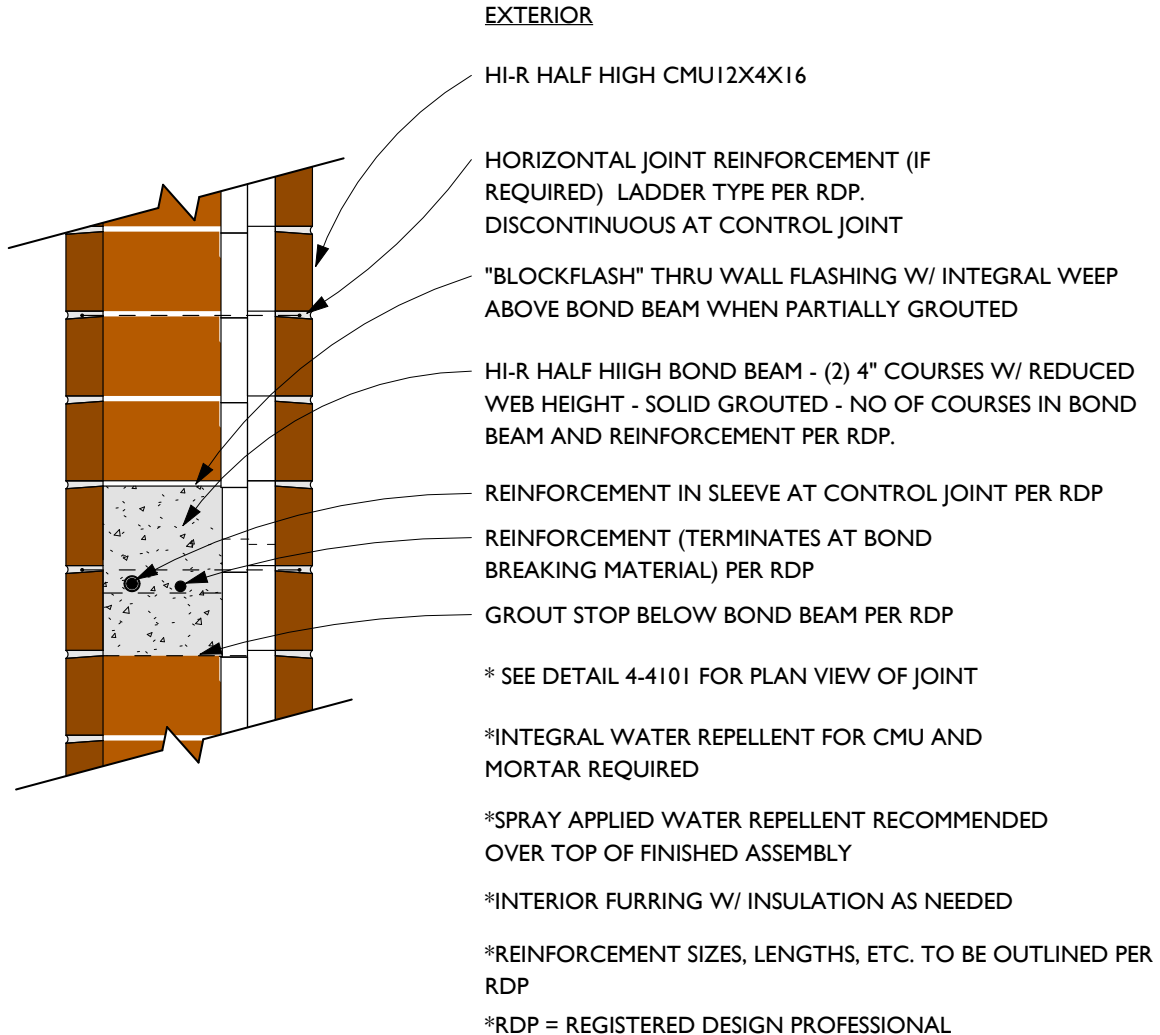

\*THIS DETAIL IS A STANDARD DETAIL. DESIGNERS SHOULD MAKE SITE SPECIFIC INVESTIGATIONS TO DETERMINE ACTUAL DESIGN REQUIREMENTS.

## Control Joint

### Detail 4-4101 - HI-R Half High - Michigan Style Control Joint at Bond Beam - Plan View

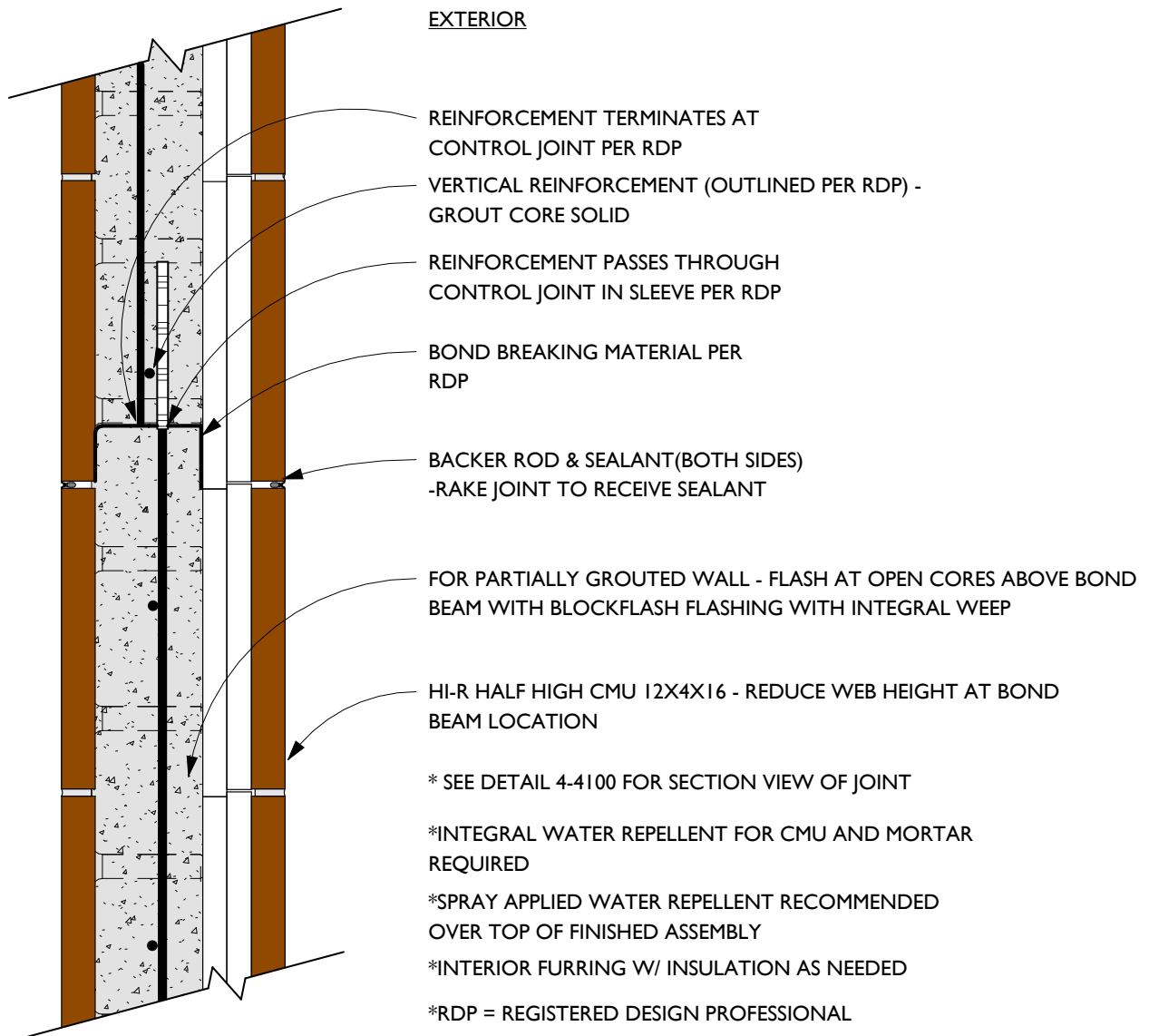

\*THIS DETAIL IS A STANDARD DETAIL. DESIGNERS SHOULD MAKE SITE SPECIFIC INVESTIGATIONS TO DETERMINE ACTUAL DESIGN REQUIREMENTS.

Control Joint

Detail 4-4102 - HI-R Half High - Control Joint

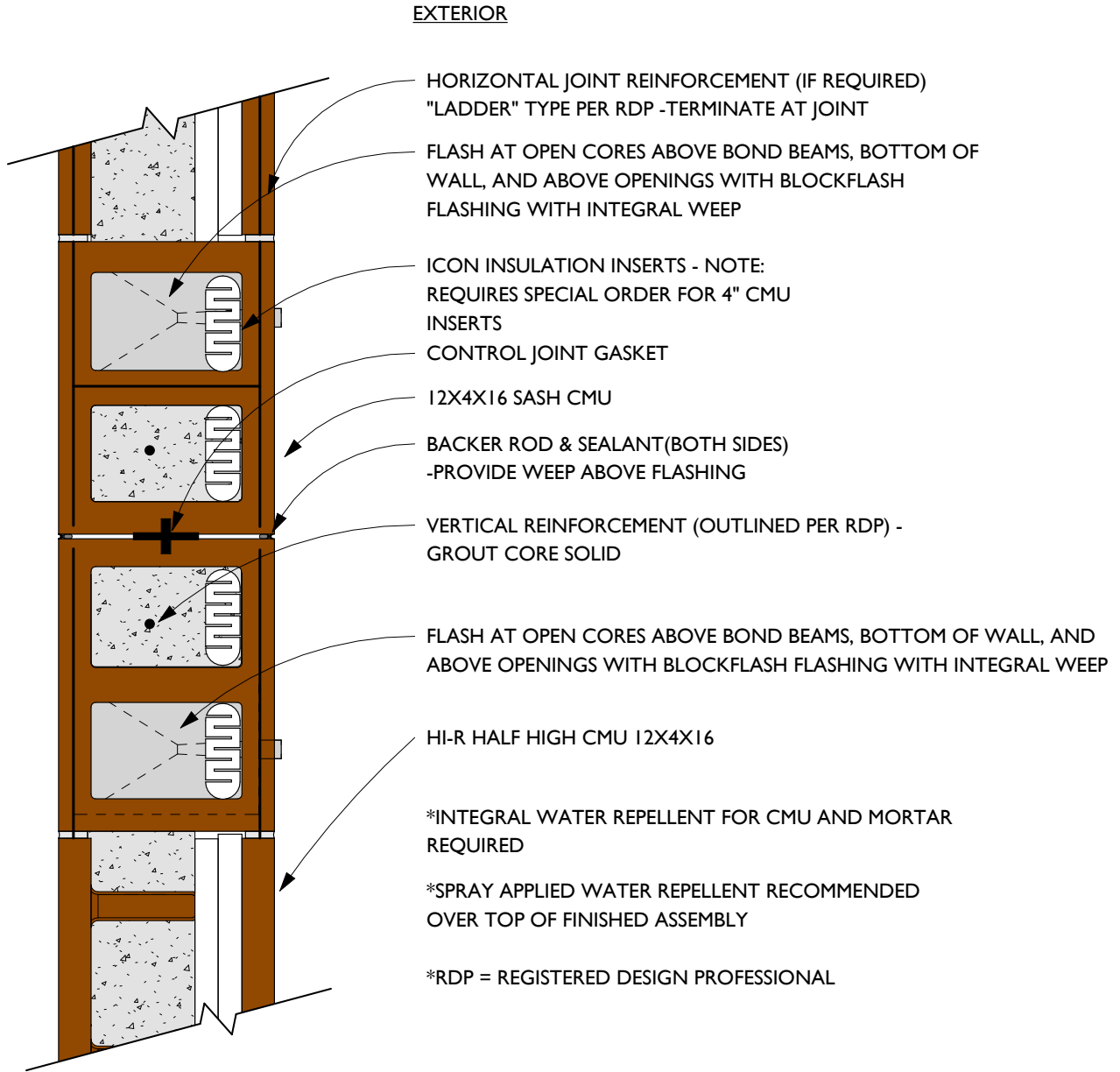

\*THIS DETAIL IS A STANDARD DETAIL. DESIGNERS SHOULD MAKE SITE SPECIFIC INVESTIGATIONS TO DETERMINE ACTUAL DESIGN REQUIREMENTS.

Detail 4-4103 - HI-R Half High - Bond Beam

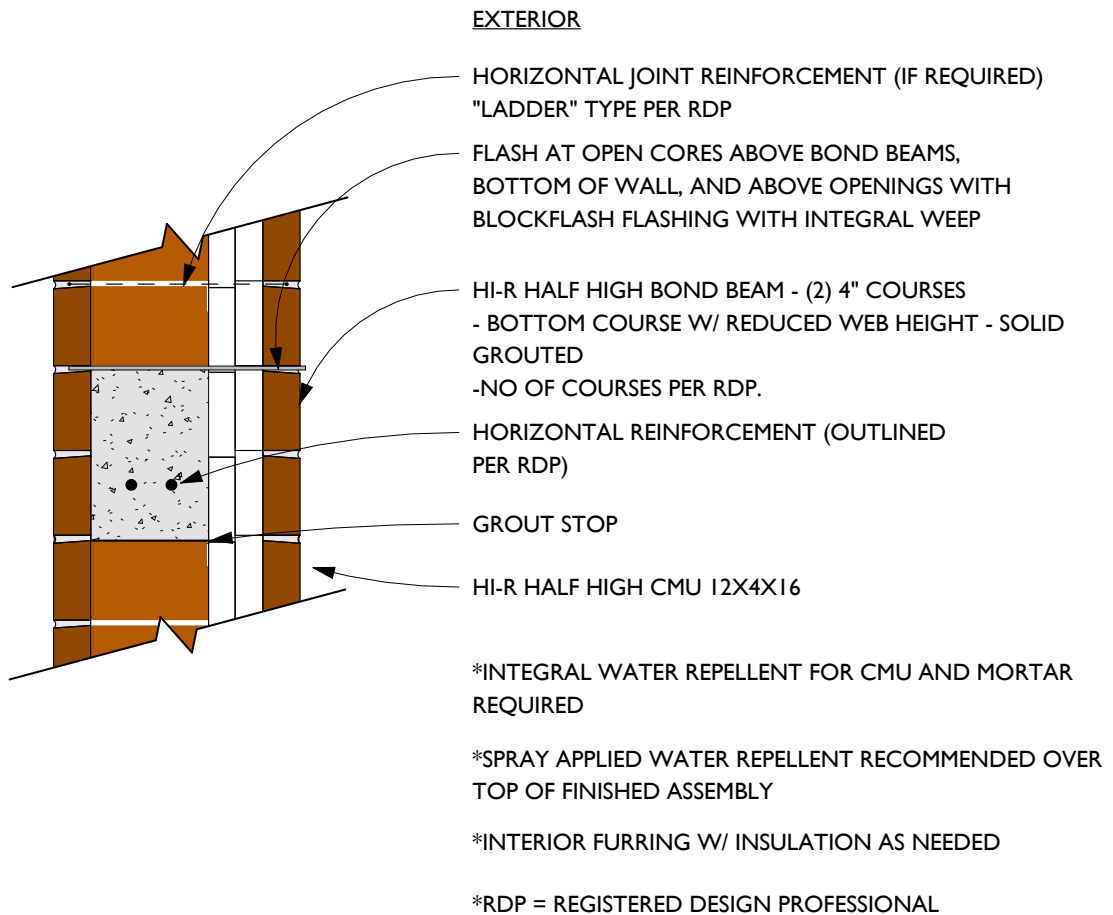

\*THIS DETAIL IS A STANDARD DETAIL. DESIGNERS SHOULD MAKE SITE SPECIFIC INVESTIGATIONS TO DETERMINE ACTUAL DESIGN REQUIREMENTS.

Horizontal Joint Reinforcement

Detail 4-4104 - HI-R Half High - Horizontal Joint Reinforcement

EXTERIOR

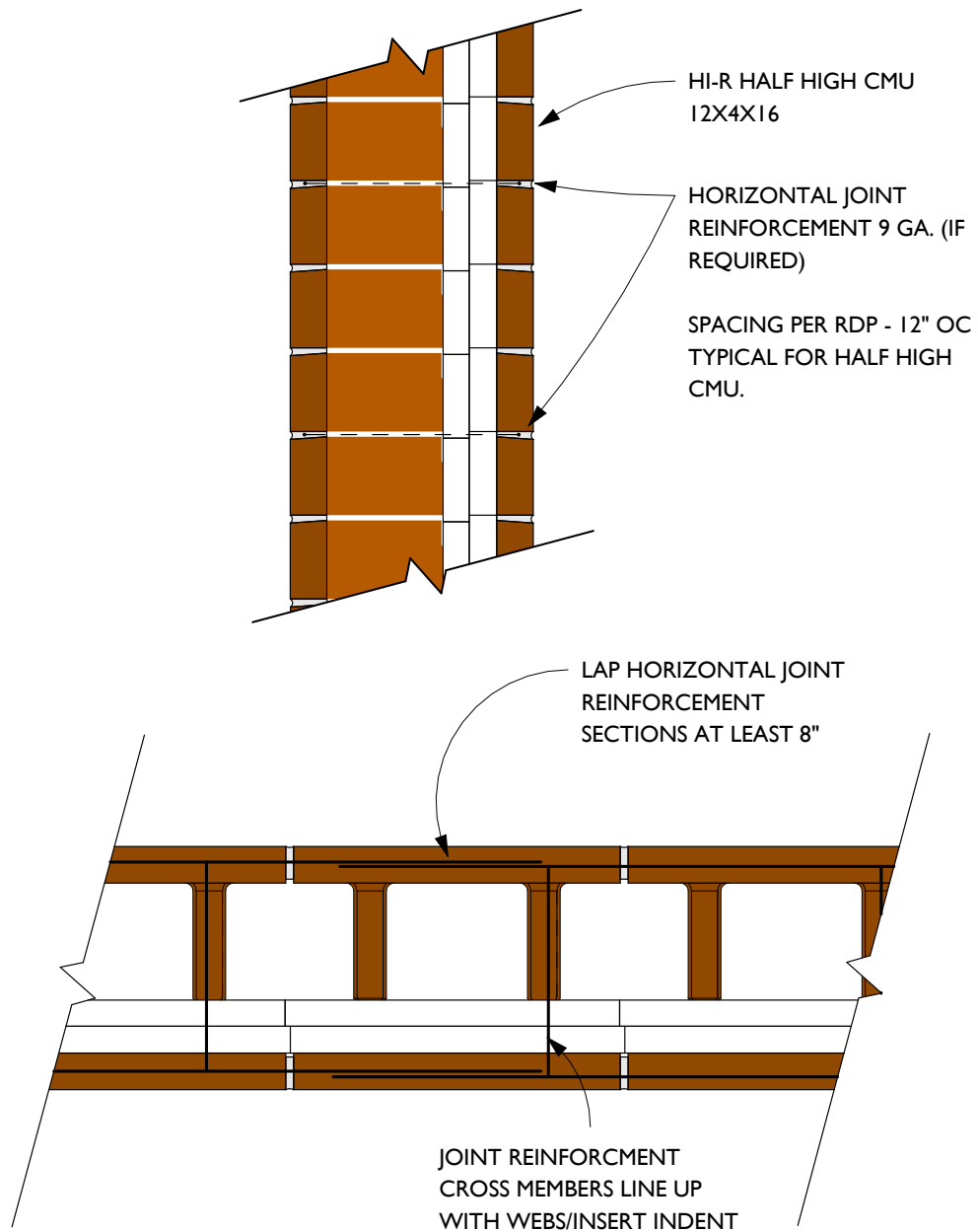

\*THIS DETAIL IS A STANDARD DETAIL. DESIGNERS SHOULD MAKE SITE SPECIFIC INVESTIGATIONS TO DETERMINE ACTUAL DESIGN REQUIREMENTS.

### Additional Notes Bond Beams and Joint

1. For half high units, the CMHA (formerly NCMA) recommends crack control horizontal joint reinforcement be placed at 12" OC vertically.
2. Bond beams are typically built using HI-R Half High units with reduced web heights. This is typically done by saw cutting the web to make the unit a knock out bond beam unit.
3. The Michigan style control joint allows the joint to have the same thermal properties as the main stretcher units. It is a more labor intensive choice compared to using the joint with a pre-formed gasket and sash unit. The trade-off is greater thermal performance vs. construction efficiency.
4. The HI-R system is designed to accommodate 9 ga. ladder type horizontal joint reinforcement. The insulation inserts have a slight indentation that aligns with the unit webs. HJR should be placed with the cross rods located at these indentations and block webs. 16" spacing of the cross rods is typical.
5. Control joints are a method to assist in controlling cracking in concrete masonry walls by allowing discrete panels in the field of a larger wall to accommodate shrinkage. There are a variety of methods to construct a control joint.
6. There are a variety of construction joints with differing names and purposes (and consistency of usage has been an issue). The joints shown in this manual are used with these meanings:
  - **Control Joint** – A joint used to break up a large field of concrete masonry into discrete panels for the purpose of allowing shrinkage and mitigating cracking.
  - **Movement Joint** – A generic term for a joint that may be intended to serve in multiple functions or accommodate multiple sources of movement.
  - **Relief Joint** – A weakened section of reinforced concrete masonry used to control and isolate the formation of shrinkage related cracks.
7. Though not depicted here, another important use for joints is in areas where there are interfaces between materials that may have different expansion properties. One example would be placing a section of clay brick (tends to expand over time) above or below a section of concrete masonry (tends to shrink over time) in a wall. Placing a joint between the differing materials will accommodate any slight differential in expansion/contraction properties.
8. In general, the specific spacing and placement of control joints for a project should be reviewed by the project structural engineer who can design the joint spacing in the most efficient manner. Refer to the CMHA (formerly NCMA) TEK notes for required horizontal reinforcement for crack control based on upon joint sizes and locations selected by RDP. Horizontal reinforcement can be provided by either use of horizontal joint reinforcement or horizontal reinforcing rebar.
9. For best results, **remember masonry modularity when placing joints (also true for designing the length and height for walls and the size and placement of openings)** This means these locations should be in multiples of 8 inches from the end of the wall. Designing with modularity in mind will result in optimal efficiency when the wall is built, because if the dimensions are not consistent with masonry modularity then the mason contractor will have to cut units in the field to fit the design.

Corners

Detail 4-4120 - HI-R Half High - Corner - 12X8X16 - CMU Fitting Course 1

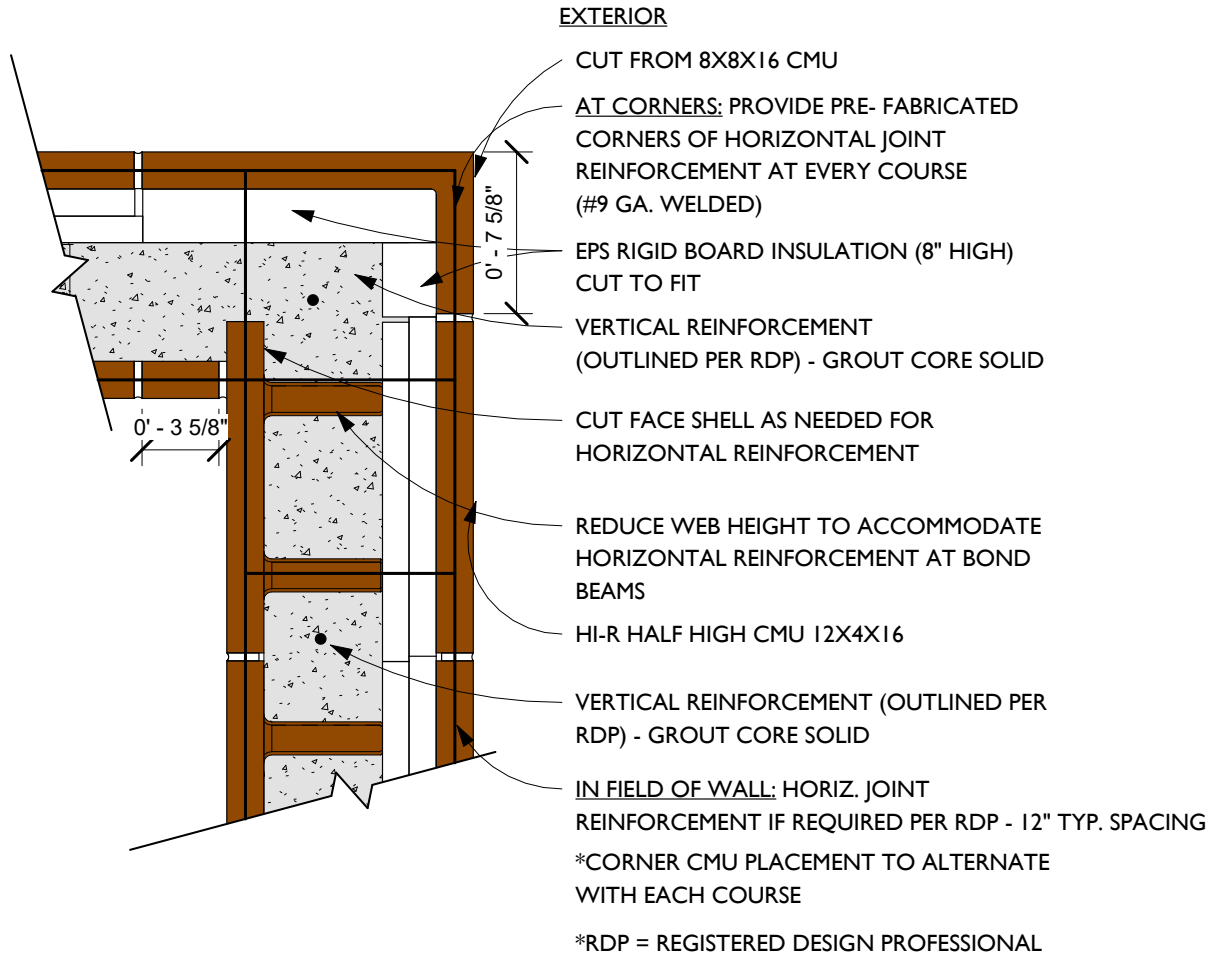

\*THIS DETAIL IS A STANDARD DETAIL. DESIGNERS SHOULD MAKE SITE SPECIFIC INVESTIGATIONS TO DETERMINE ACTUAL DESIGN REQUIREMENTS.

## Corners

### Detail 4-4121 - HI-R Half High - Corner - 12X8X16 - CMU Fitting Course 2

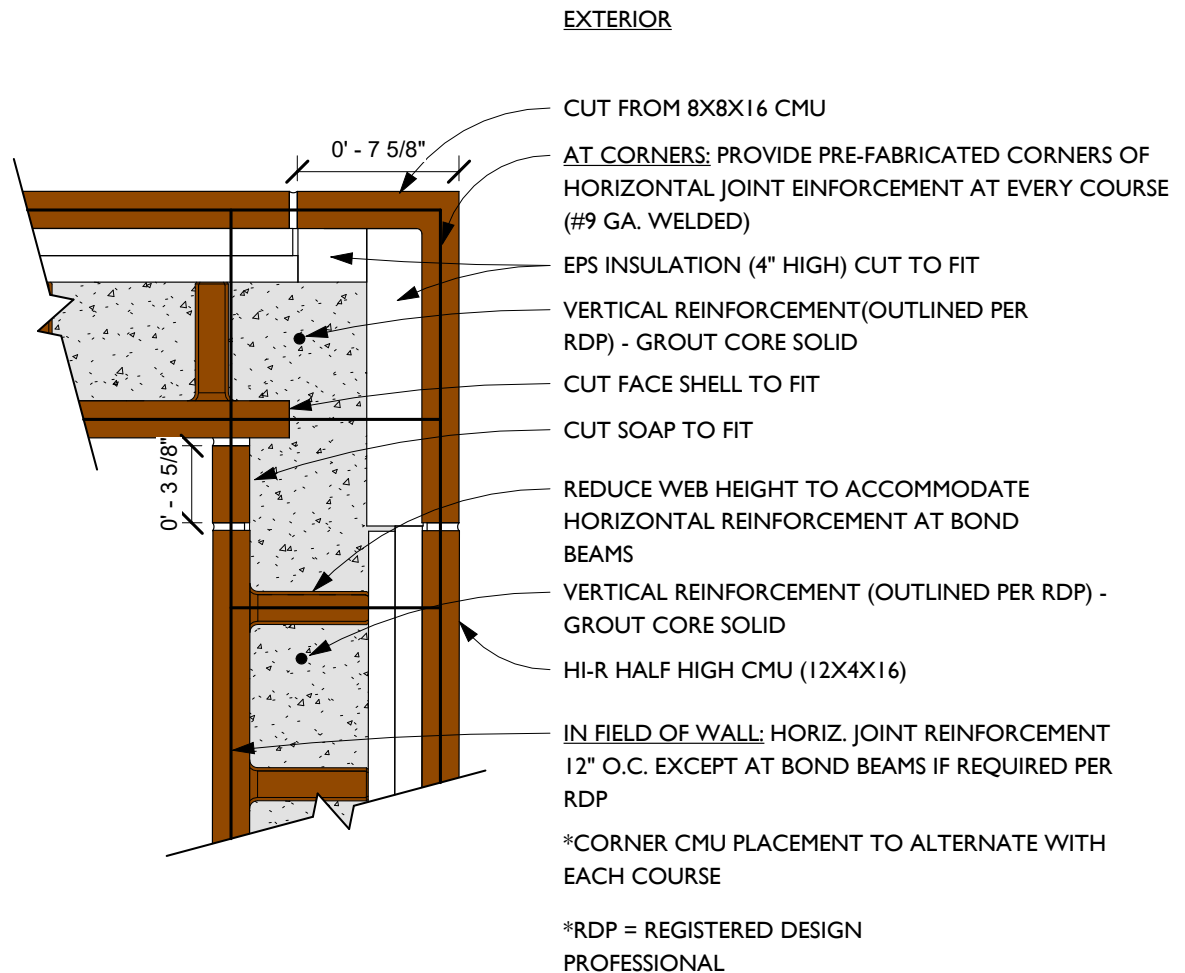

\*THIS DETAIL IS A STANDARD DETAIL. DESIGNERS SHOULD MAKE SITE SPECIFIC INVESTIGATIONS TO DETERMINE ACTUAL DESIGN REQUIREMENTS.

### **Additional Notes – Corners:**

1. The use of an L-Shaped fitting and a soap cut from an 8X8X16 CMU has proven to a popular choice for building corners. Another method uses a 8×8×16 corner unit with Icon® insulation but this style of corner has thermal bridges so that it does not protect the corner as well thermally.
2. The EPS corner pieces should be at least as thick as the HI-R insulation inserts to provide insulation as good or better than the HI-R units.
3. All details are available in Revit® and AutoCAD® – the numbering of the details in this manual corresponds to that used in the Revit® and AutoCAD® files.

## Window Openings - Lintels

### Detail 4-4200 - HI-R Half High - Window Head & Lintel with HI-R Half High Units

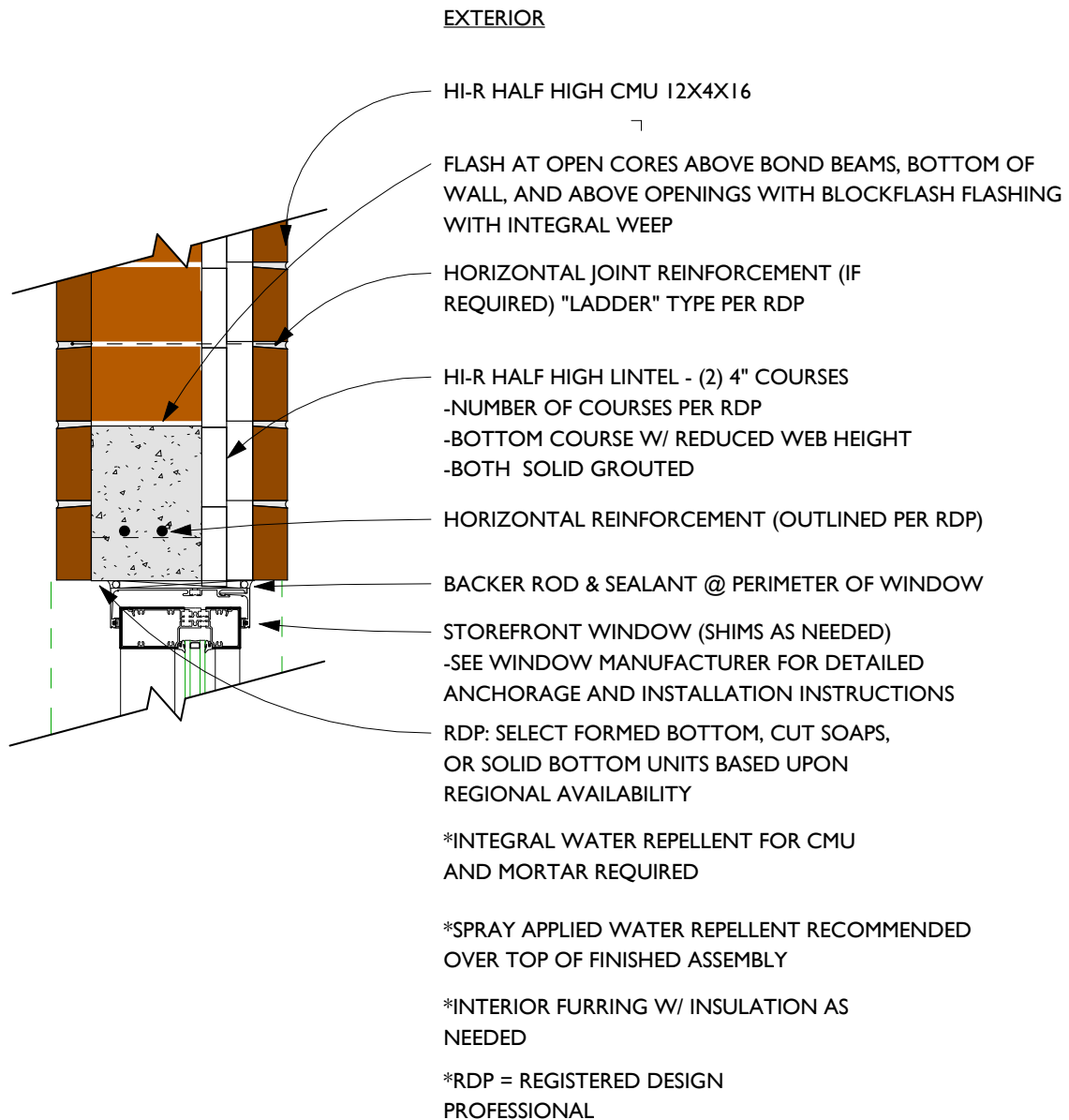

\*THIS DETAIL IS A STANDARD DETAIL. DESIGNERS SHOULD MAKE SITE SPECIFIC INVESTIGATIONS TO DETERMINE ACTUAL DESIGN REQUIREMENTS.

**Detail 4-4201 - HI-R Half High - Window Head & Lintel Using HI-R/HI-R-H Closed Bottom Lintel**

PLEASE CONFIRM  
LOCAL AVAILABILITY  
OF HI-R/HI-R-H CLOSED BOTTOM LINTEL  
PRIOR  
TO SPECIFYING

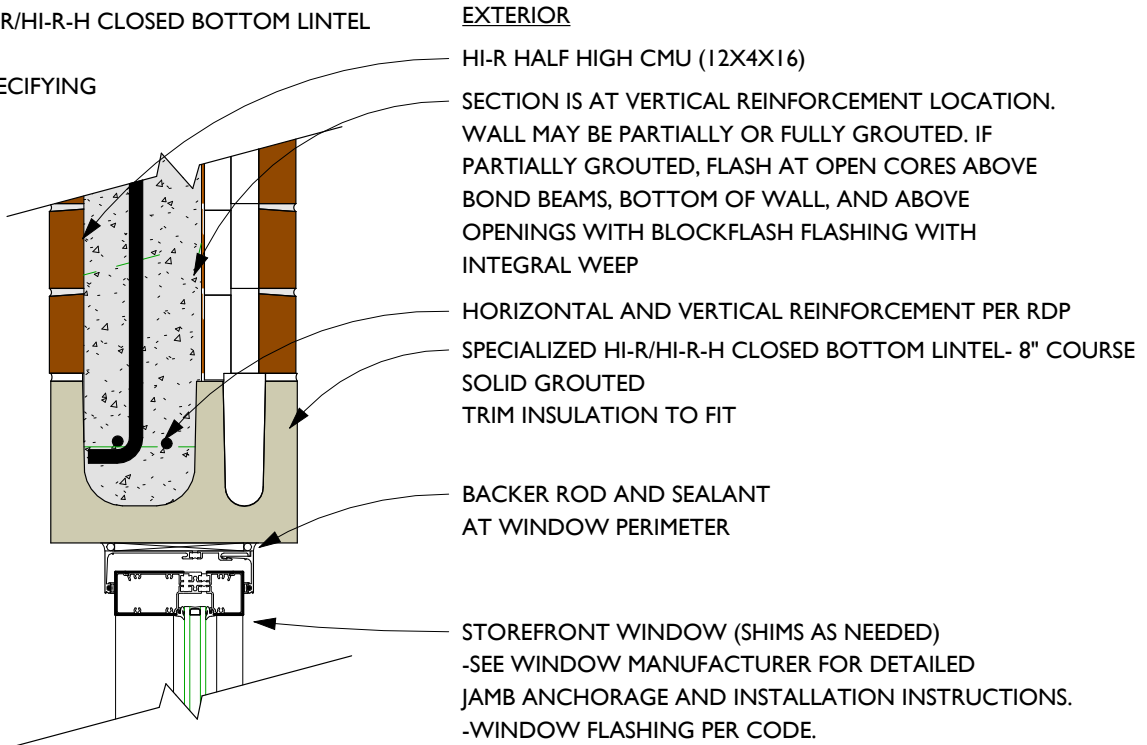

\*THIS DETAIL IS A STANDARD DETAIL. DESIGNERS SHOULD MAKE SITE SPECIFIC INVESTIGATIONS TO DETERMINE ACTUAL DESIGN REQUIREMENTS.

**Detail 4-4202 - HI-R Half High - Window Jamb with CMU Jamb**

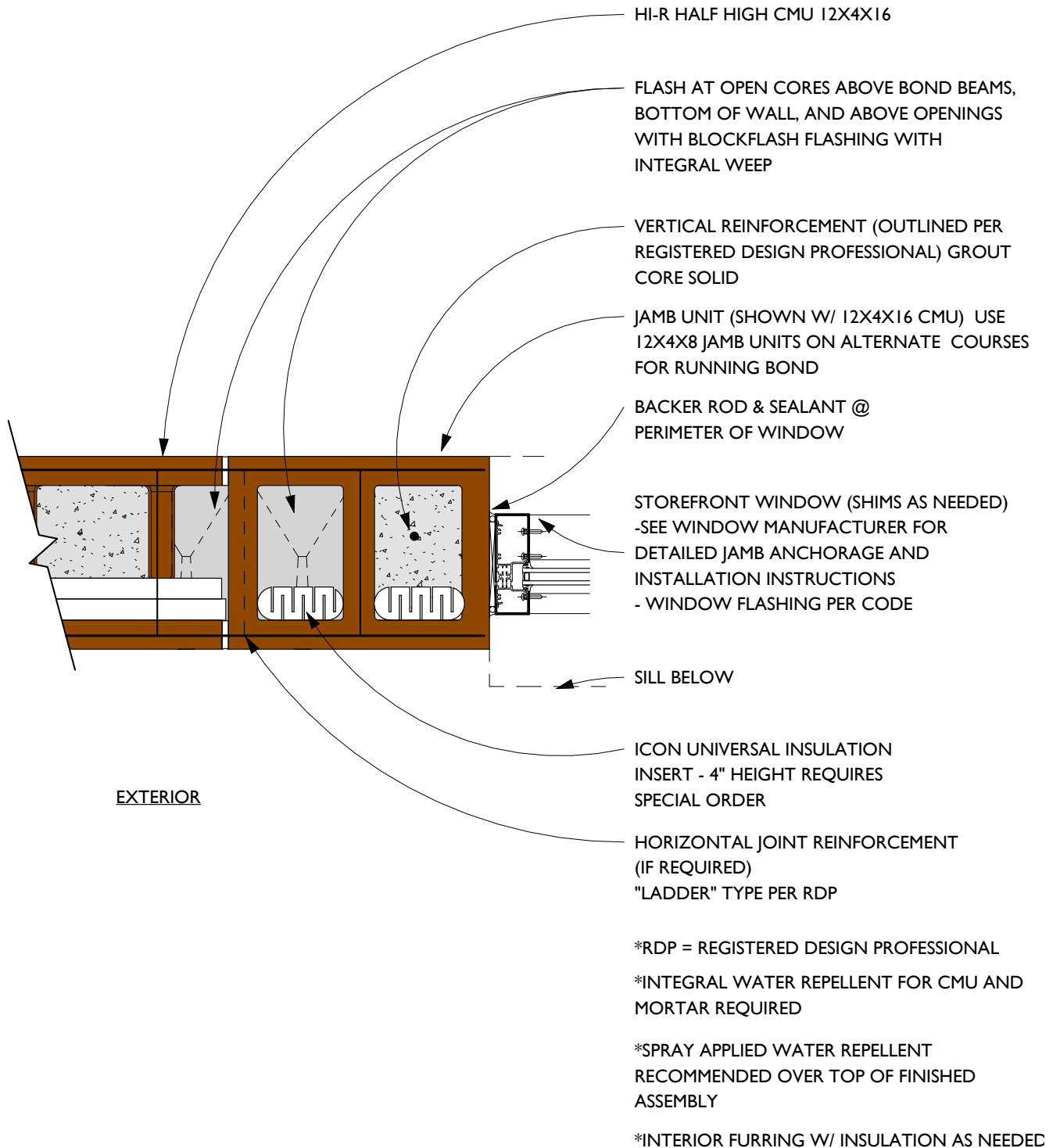

\*THIS DETAIL IS A STANDARD DETAIL. DESIGNERS SHOULD MAKE SITE SPECIFIC INVESTIGATIONS TO DETERMINE ACTUAL DESIGN REQUIREMENTS.

Detail 4-4205 - HI-R Half High - 4" Sill

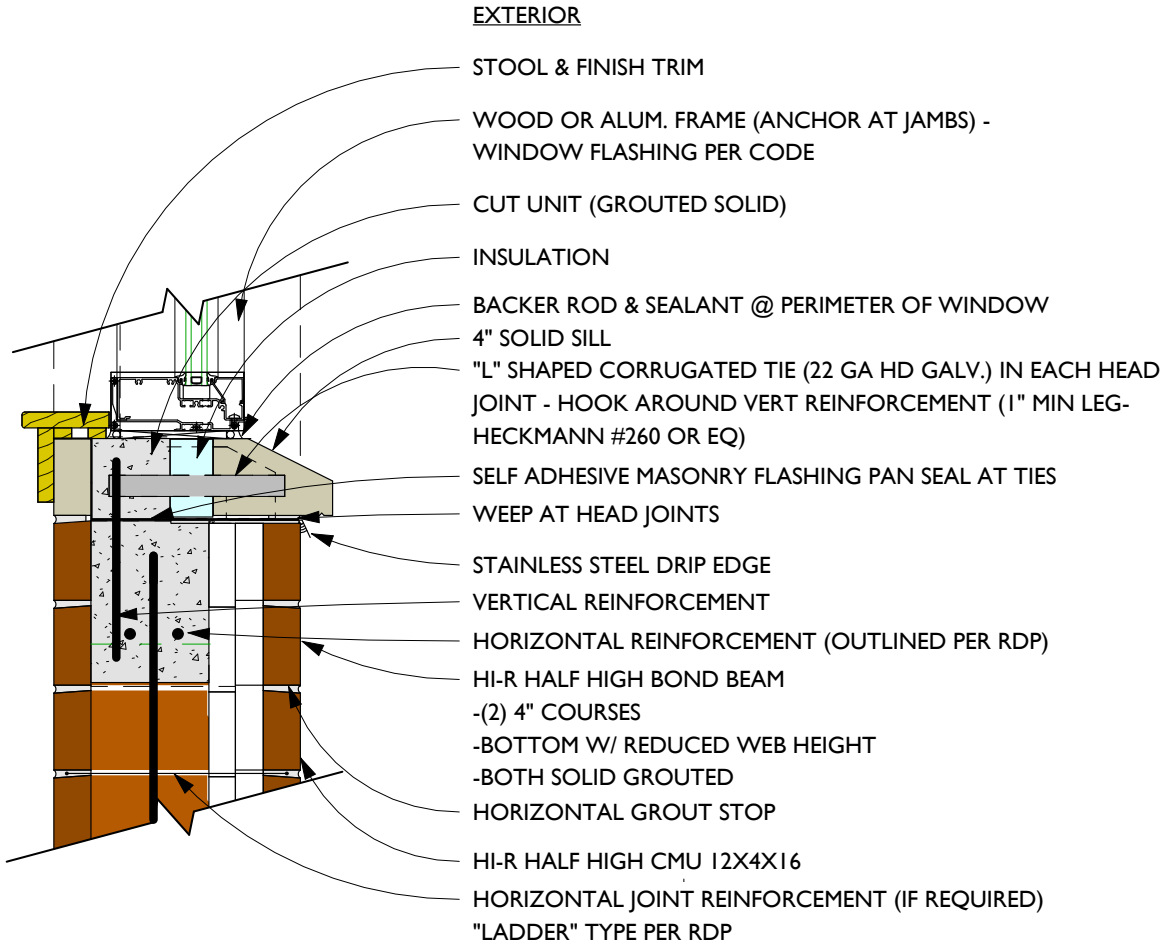

\*INTEGRAL WATER REPELLENT FOR CMU AND MORTAR REQUIRED

\*SPRAY APPLIED WATER REPELLENT RECOMMENDED OVER TOP OF FINISHED ASSEMBLY

\*INTERIOR FURRING W/ INSULATION AS NEEDED

\*RDP = REGISTERED DESIGN PROFESSIONAL

\*THIS DETAIL IS A STANDARD DETAIL. DESIGNERS SHOULD MAKE SITE SPECIFIC INVESTIGATIONS TO DETERMINE ACTUAL DESIGN REQUIREMENTS.

**Window Openings - Sills**

**Detail 4-4206 - HI-R Half High - 8" Sill**

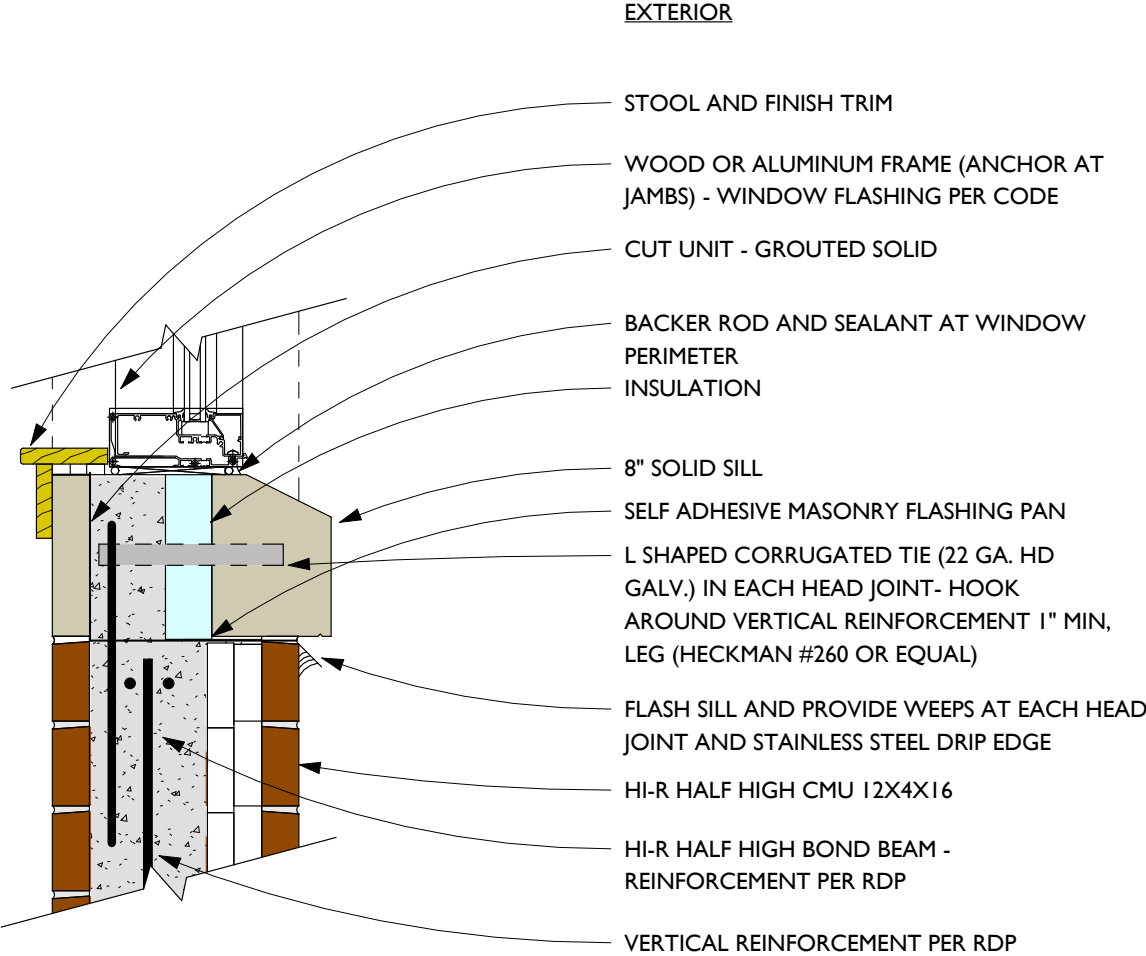

EXTERIOR

- STOOL AND FINISH TRIM
- WOOD OR ALUMINUM FRAME (ANCHOR AT JAMBS) - WINDOW FLASHING PER CODE
- CUT UNIT - GROUTED SOLID
- BACKER ROD AND SEALANT AT WINDOW PERIMETER
- INSULATION
- 8" SOLID SILL
- SELF ADHESIVE MASONRY FLASHING PAN
- L SHAPED CORRUGATED TIE (22 GA. HD GALV.) IN EACH HEAD JOINT- HOOK AROUND VERTICAL REINFORCEMENT 1" MIN, LEG (HECKMAN #260 OR EQUAL)
- FLASH SILL AND PROVIDE WEEPS AT EACH HEAD JOINT AND STAINLESS STEEL DRIP EDGE
- HI-R HALF HIGH CMU 12X4X16
- HI-R HALF HIGH BOND BEAM - REINFORCEMENT PER RDP
- VERTICAL REINFORCEMENT PER RDP

\*INTEGRAL WATER REPELLENT FOR CMU AND MORTAR REQUIRED

\*SPRAY APPLIED WATER REPELLENT RECOMMENDED OVER TOP OF FINISHED ASSEMBLY

\*INTERIOR FURRING W/ INSULATION AS NEEDED

\*RDP = REGISTERED DESIGN PROFESSIONAL

\*THIS DETAIL IS A STANDARD DETAIL. DESIGNERS SHOULD MAKE SITE SPECIFIC INVESTIGATIONS TO DETERMINE ACTUAL DESIGN REQUIREMENTS.

**Additional Notes – Window openings:**

1. Lintel may either be formed from HI-R Half High units with reduced webs (see notes regarding bond beams) or by using a specialized insulated HI-R/HI-R-H closed bottom lintel unit. This unit is only available in certain regions, so please check first before specifying. Lintels formed from HI-R Half High units will require a surface treatment such as parging or finish trim since the lintel is open bottomed and the grout and inserts may be revealed without a finish treatment.
2. Jambs are typically formed using a CMU jamb unit with Icon® inserts. The thermal properties of the jamb should be considered when performing Energy Code compliance calculations.
3. Details 4-4205 and 4-4206 show an insulated Window sill – choose rigid board insulation with sufficient thickness to meet requirements. Anchorage for sills shown for 16" partial sill units; modify for larger units.
4. All details are available in Revit® and AutoCAD® – the numbering of the details in this manual corresponds to that used in the Revit® and AutoCAD® files.



**Forms supporting lintel during construction (shown with HI-R-H units)**

Detail 4-4210 – HI-R Half High – Door Head – HI-R Half High Stretcher for Lintel

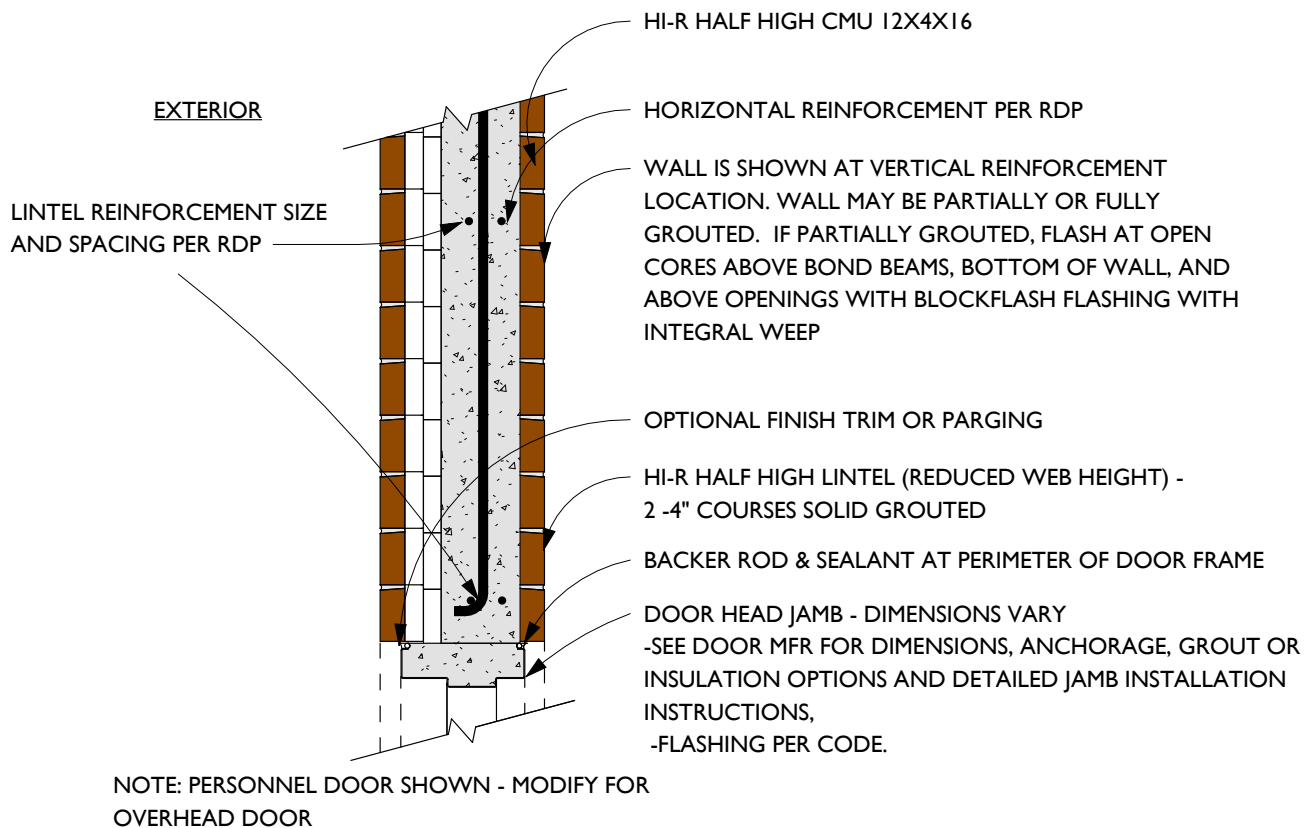

\*THIS DETAIL IS A STANDARD DETAIL. DESIGNERS SHOULD MAKE SITE SPECIFIC INVESTIGATIONS TO DETERMINE ACTUAL DESIGN REQUIREMENTS.

Detail 4-4211 – HI-R Half High – Door Head – HI-R/HI-R-H Closed Bottom Lintel Unit

PLEASE CONFIRM  
LOCAL AVAILABILITY  
OF HI-R/HI-R-H CLOSED BOTTOM LINTEL  
PRIOR  
TO SPECIFYING

EXTERIOR

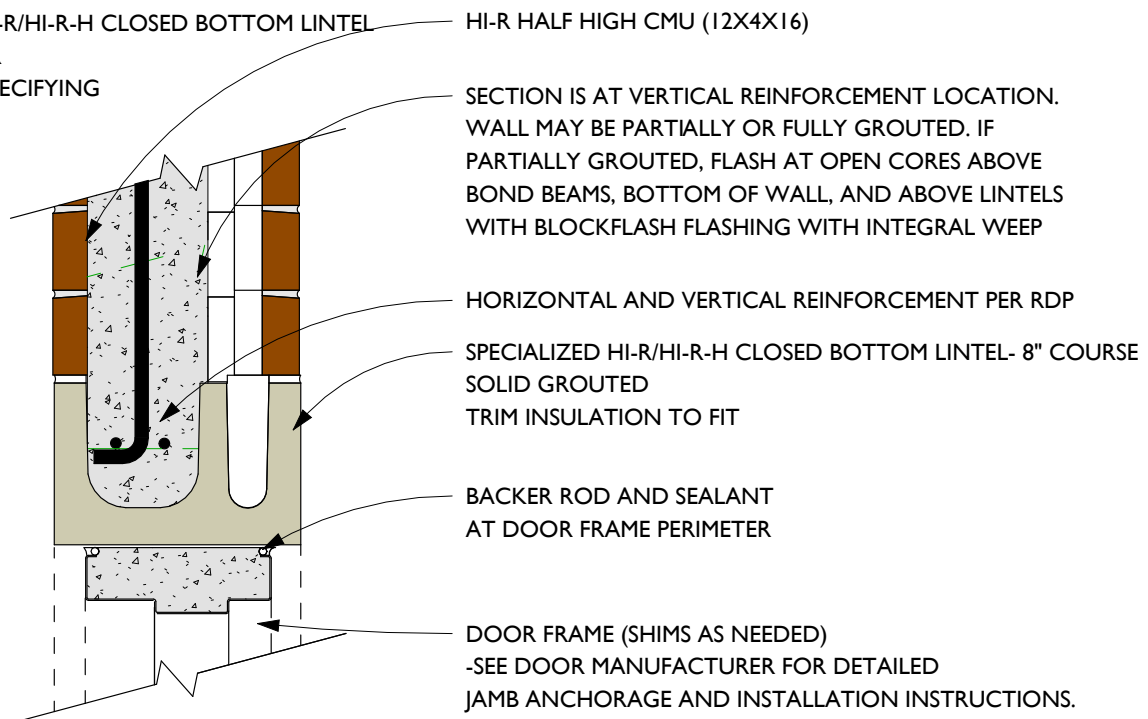

\*THIS DETAIL IS A STANDARD DETAIL. DESIGNERS SHOULD MAKE SITE SPECIFIC INVESTIGATIONS TO DETERMINE ACTUAL DESIGN REQUIREMENTS.

## Door Openings

### Detail 4-4212 - HI-R Half High - Door Jamb

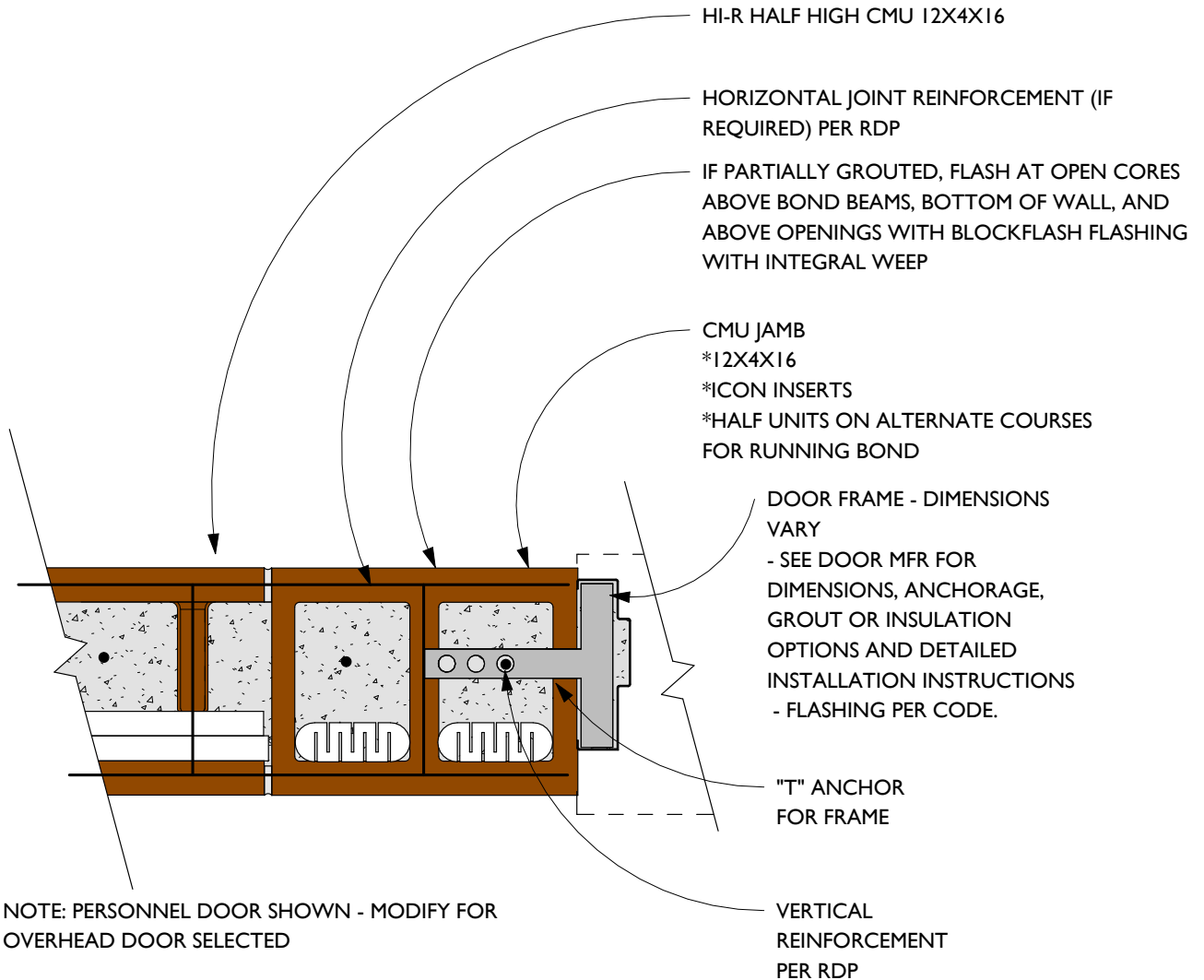

\*THIS DETAIL IS A STANDARD DETAIL. DESIGNERS SHOULD MAKE SITE SPECIFIC INVESTIGATIONS TO DETERMINE ACTUAL DESIGN REQUIREMENTS.

### **Additional Notes – Door openings:**

1. See notes to Window openings.
2. All details are available in Revit® and AutoCAD® – the numbering of the details in this manual corresponds to that used in the Revit® and AutoCAD® files.

Detail 4-4300 - HI-R Half High - Precast Plank Bearing Wall

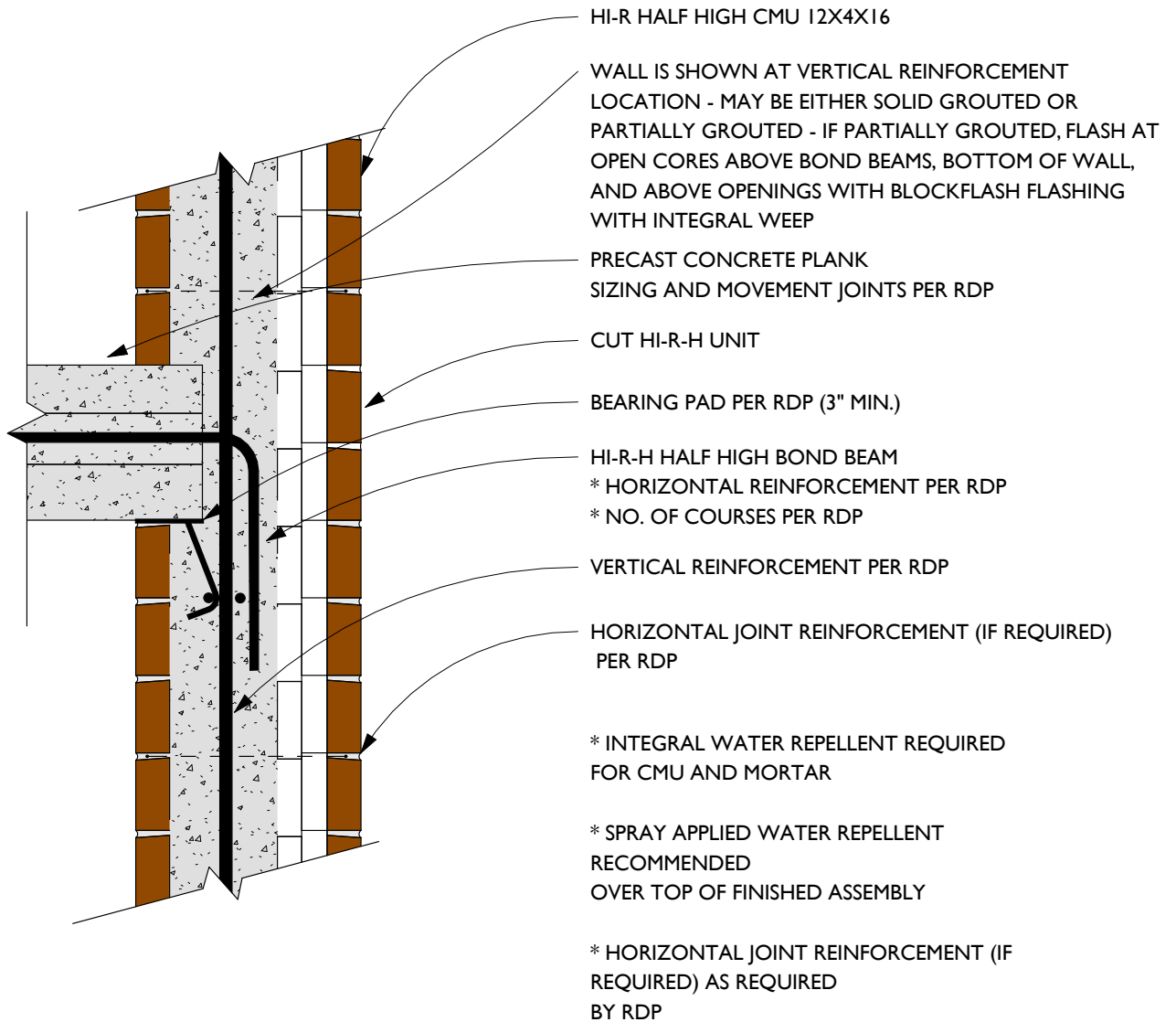

\*THIS DETAIL IS A STANDARD DETAIL. DESIGNERS SHOULD MAKE SITE SPECIFIC INVESTIGATIONS TO DETERMINE ACTUAL DESIGN REQUIREMENTS.

Detail 4-4301 - HI-R Half High - Precast Plank Non-Bearing Wall

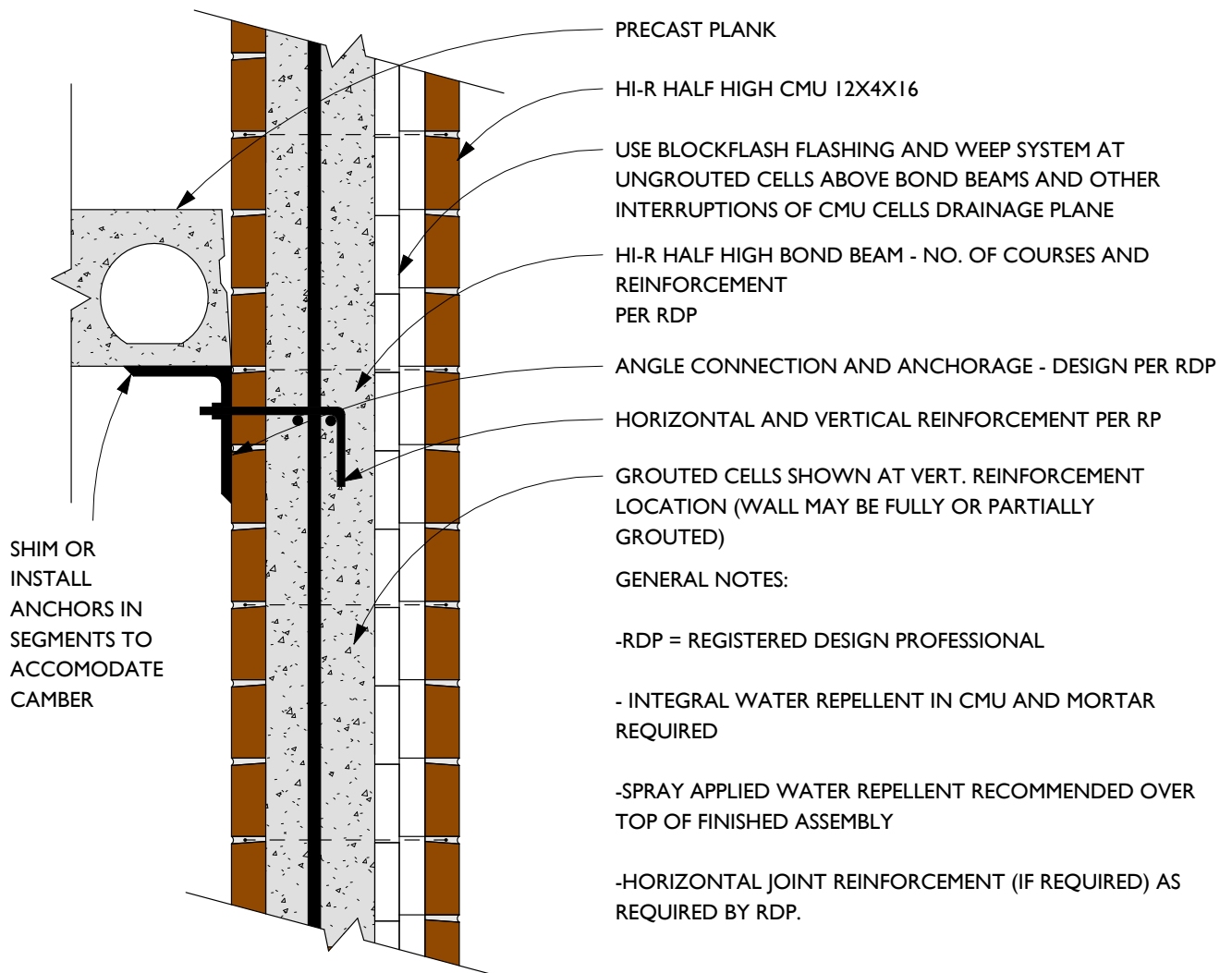

\*THIS DETAIL IS A STANDARD DETAIL. DESIGNERS SHOULD MAKE SITE SPECIFIC INVESTIGATIONS TO DETERMINE ACTUAL DESIGN REQUIREMENTS.

**Additional Notes – Planks:**

1. See Detail 4-4103 regarding bond beams.
2. All details are available in Revit® and AutoCAD® – the numbering of the details in this manual corresponds to that used in the Revit® and AutoCAD® files.

Detail 4-4310 - HI-R Half High - Parapet Bearing Wall

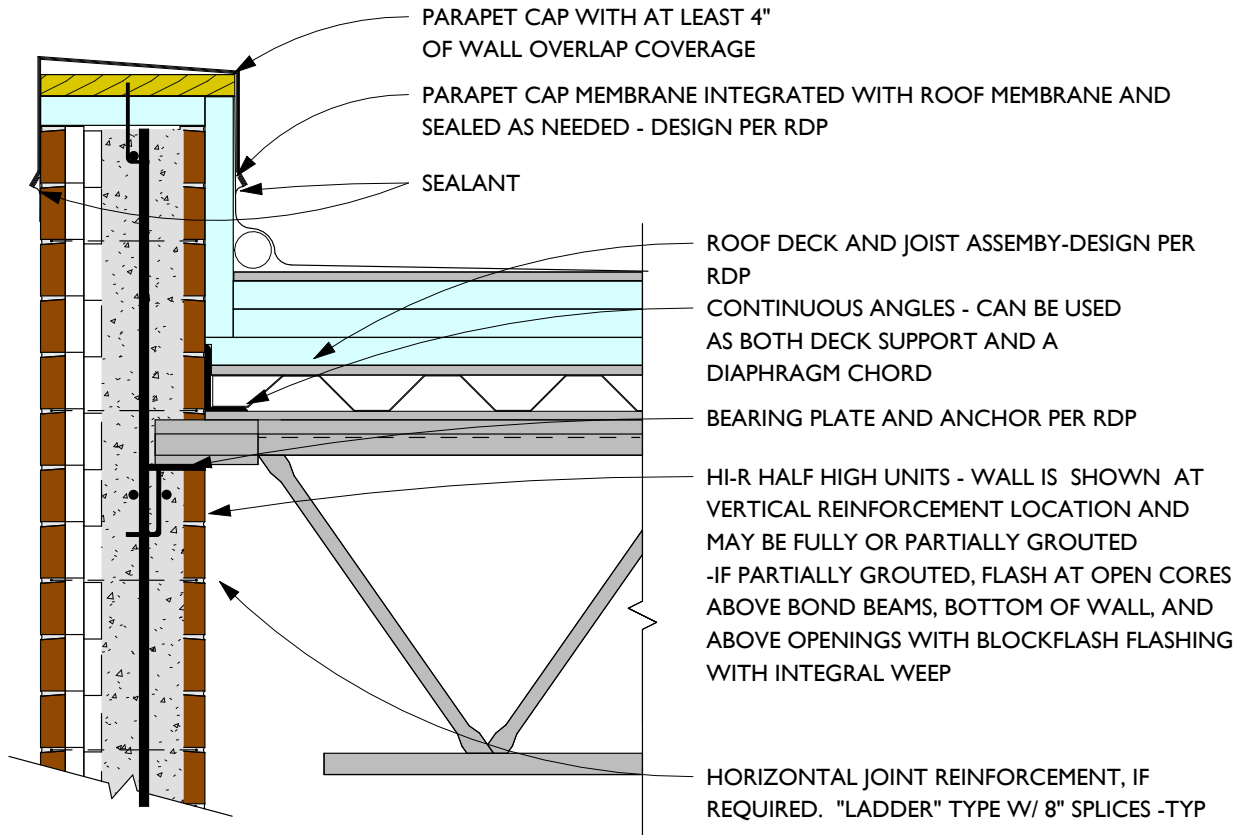

\*RDP = REGISTERED DESIGN PROFESSIONAL

\*INTEGRAL WATER REPELLENT FOR CMU AND MORTAR REQUIRED

\*SPRAY APPLIED WATER REPELLENT RECOMMENDED OVER TOP OF FINISHED ASSEMBLY

\*THIS DETAIL IS A STANDARD DETAIL. DESIGNERS SHOULD MAKE SITE SPECIFIC INVESTIGATIONS TO DETERMINE ACTUAL DESIGN REQUIREMENTS.

Detail 4-4311 - HI-R Half High - Parapet Non-Bearing Wall

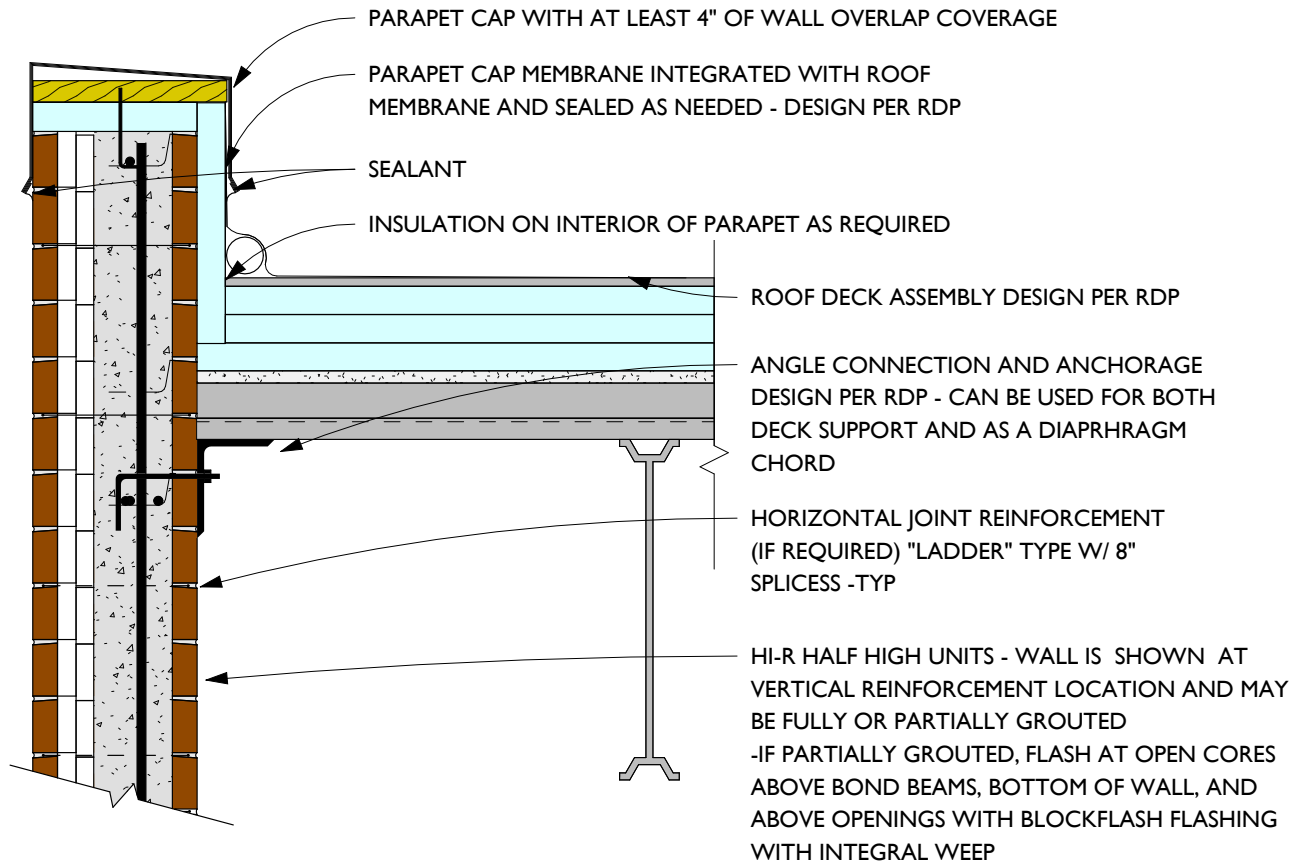

\*RDP = REGISTERED DESIGN PROFESSIONAL

\*INTEGRAL WATER REPELLENT FOR CMU AND MORTAR REQUIRED

\*SPRAY APPLIED WATER REPELLENT RECOMMENDED OVER TOP OF FINISHED ASSEMBLY

\*THIS DETAIL IS A STANDARD DETAIL. DESIGNERS SHOULD MAKE SITE SPECIFIC INVESTIGATIONS TO DETERMINE ACTUAL DESIGN REQUIREMENTS.

**Additional Notes – Roof Joist and Parapet:**

1. See detail 4-4103 regarding bond beams.
2. Insulating the inward face of the parapet provides protection against thermal bridging at that location.
3. All details are available in Revit® and AutoCAD® – the numbering of the details in this manual corresponds to that used in the Revit® and AutoCAD® files.

Pilaster

Detail 4-4320 - HI-R Half High - Pilaster Section View

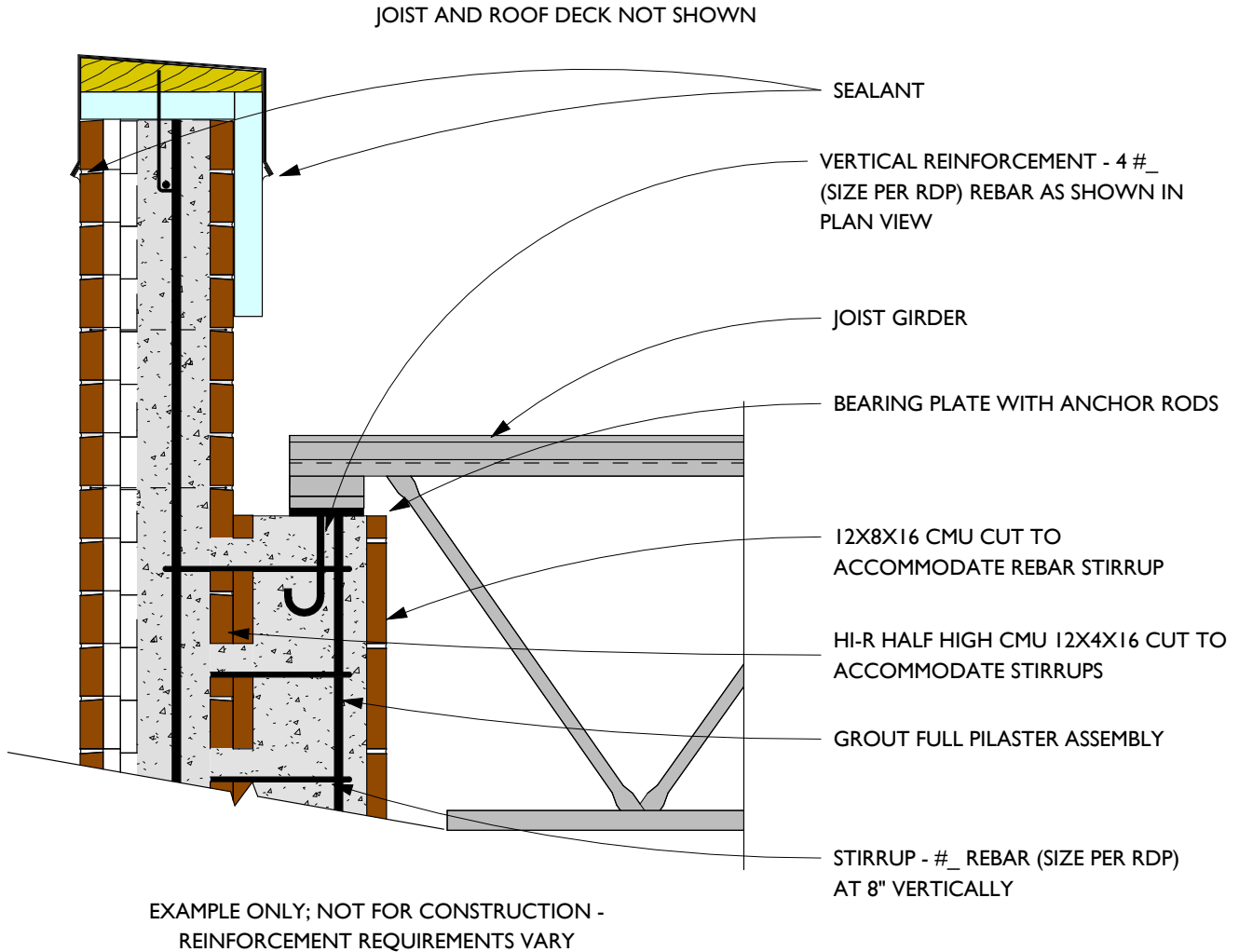

\*THIS DETAIL IS A STANDARD DETAIL. DESIGNERS SHOULD MAKE SITE SPECIFIC INVESTIGATIONS TO DETERMINE ACTUAL DESIGN REQUIREMENTS.

Detail 4-4321 - HI-R Half High - Pilaster Plan View

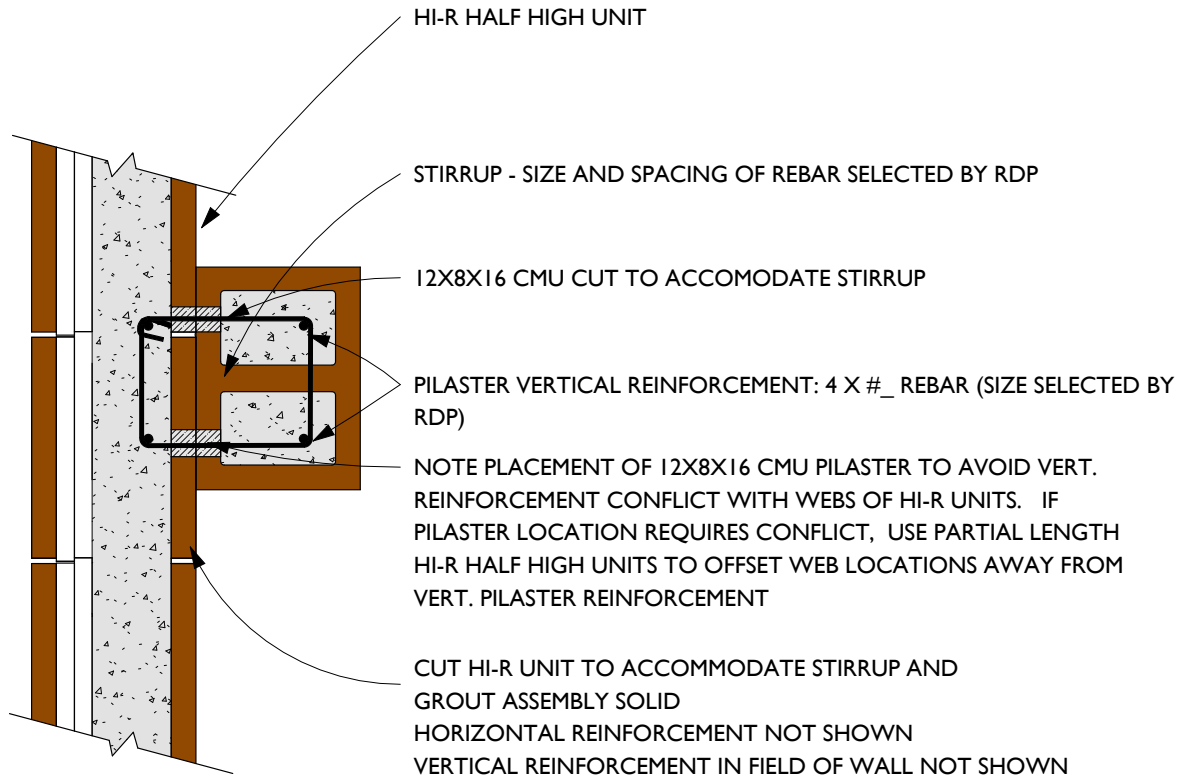

EXAMPLE ONLY; NOT FOR CONSTRUCTION -  
REINFORCEMENT REQUIREMENTS VARY

RDP = REGISTERED DESIGN PROFESSIONAL

\*THIS DETAIL IS A STANDARD DETAIL. DESIGNERS SHOULD MAKE SITE SPECIFIC INVESTIGATIONS TO DETERMINE ACTUAL DESIGN REQUIREMENTS.

**Additional Notes – Pilaster:**

1. Pilasters are often a cost-effective addition to meet structural requirements for the building roof.
2. All details are available in Revit® and AutoCAD® – the numbering of the details in this manual corresponds to that used in the Revit® and AutoCAD® files.



---

## HI-R-H Half High Construction Details

---

## Spec-Thermal HI-R-H® Half High

**HI-R-H Half High** is a single web pre-insulated masonry unit with 4" x 16" face dimension that is suitable for fully grouted walls intended for the most demanding climates and structural needs. When made with Spec-Brik colors, the product is called Spec-Brik HI-R-H

HI-R-H Half High has the thickest (4") inserts in the HI-R-H product line, and offers the highest level of thermal performance.

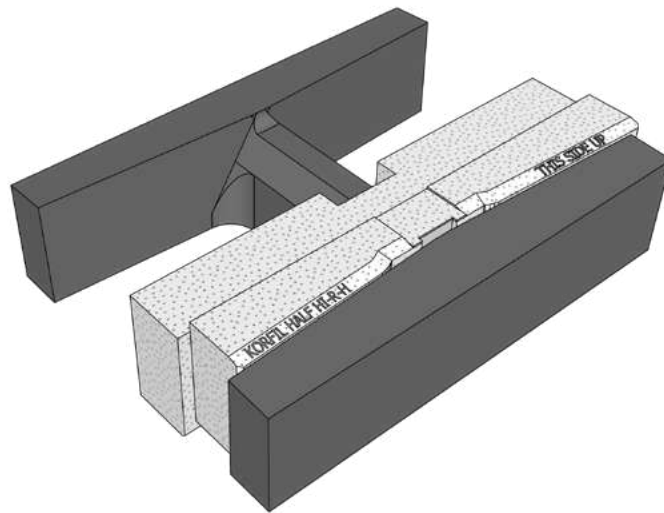

**12×4×16 Spec-Thermal  
HI-R-H Half High Unit**

### Key Features

**Aesthetics.** Double exposed masonry with brick aesthetics -durable architectural finishes inside and out.

**Thermal Performance.** Two-part 4" nominal offset interlocking EPS insulation insert – thickest insert currently available. Interlocking insulation covers all mor-

tar joints. Insert uses higher density EPS to enhance thermal performance. Single partial height web for reduced thermal bridging. Thermal mass exposed to the interior, conditioned space for optimal thermal performance Fully Grouted Wall System.

**Fully Grouted Wall Benefits.** Barrier wall performance resists moisture penetration/condensation issues with use of integral water repellent in block and mortar and post-applied water repellent sealer. Fire resistance: Four hour fire rating is typical. No additional air barrier or vapor retarder is required with fully grouted masonry walls (assumes use of integral water repellent in unit and mortar). Great choice for structures designed to be resilient against natural hazards and for demanding applications requiring extensive reinforcement.

**Construction Efficiency.** Shape eases placement even with tight reinforcement spacing. No modification to stretcher unit required for bond beam construction. Utilities (plumbing and electrical) readily fit in unit cores and groutable spaces. Single trade installs interior and exterior finishes, structure and insulation in one step- no separate construction of framing, exterior veneer and insulation is required.



**Durable Masonry Beauty – Inside and Out**

## Wall System: 12×4×16 HI-R-H Half High

### Summary of System Component Options:

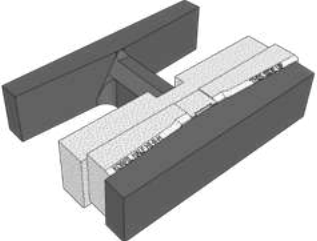
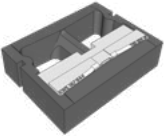
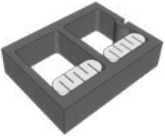
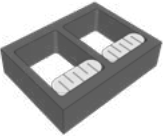
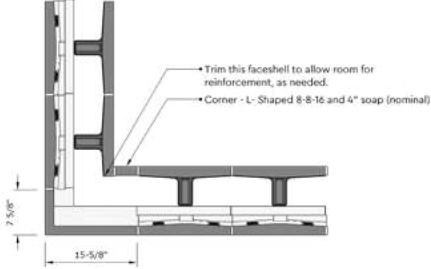
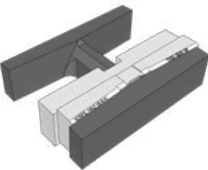
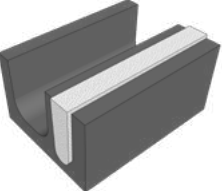
	<p><b>Main wall units:</b> HI-R-H 12×4×16 Stretcher Unit Insulation is 4" thick</p> <p><b>Bond beams:</b> HI-R-H 12×4×16 Stretcher Unit</p>			
	<p><b>Control Joints:</b> HI-R-H Half High Sash/Jamb Unit* or Half High CMU Sash</p>	 <p>HI-R-H Half High Sash/Jamb Unit</p>	 <p>CMU Sash Unit with Icon® Inserts</p>	 <p>CMU Jamb Unit with Icon® Inserts</p>
	<p><b>Jamb:</b> HI-R-H Half High Sash/Jamb Unit* or Half High CMU Jamb</p>			
	<p><b>Corners:</b> L-Shaped CMU fitting with EPS Insulation</p>			
	<p><b>Lintels:</b> HI-R-H Half High units or HI-R/HI-R-H Closed Bottom Lintel*</p>			

\* Availability may be limited in some regions. Please confirm local availability before specifying.

Detail 4-5000 HI-R-H Half High - CMU Foundation

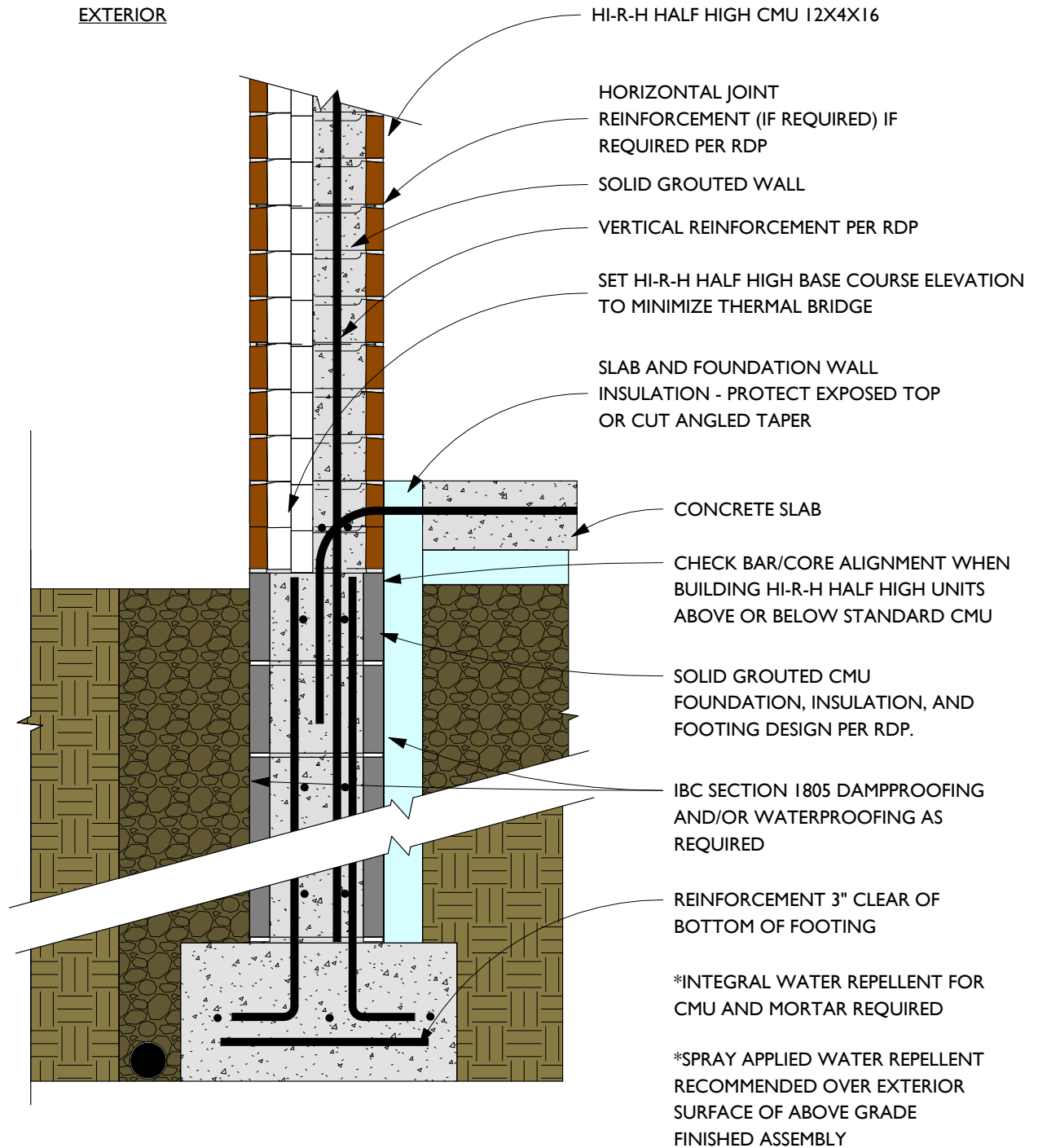

\*THIS DETAIL IS A STANDARD DETAIL. DESIGNERS SHOULD MAKE SITE SPECIFIC INVESTIGATIONS TO DETERMINE ACTUAL DESIGN REQUIREMENTS.

Detail 4-5001 - HI-R-H Half High - Concrete Foundation

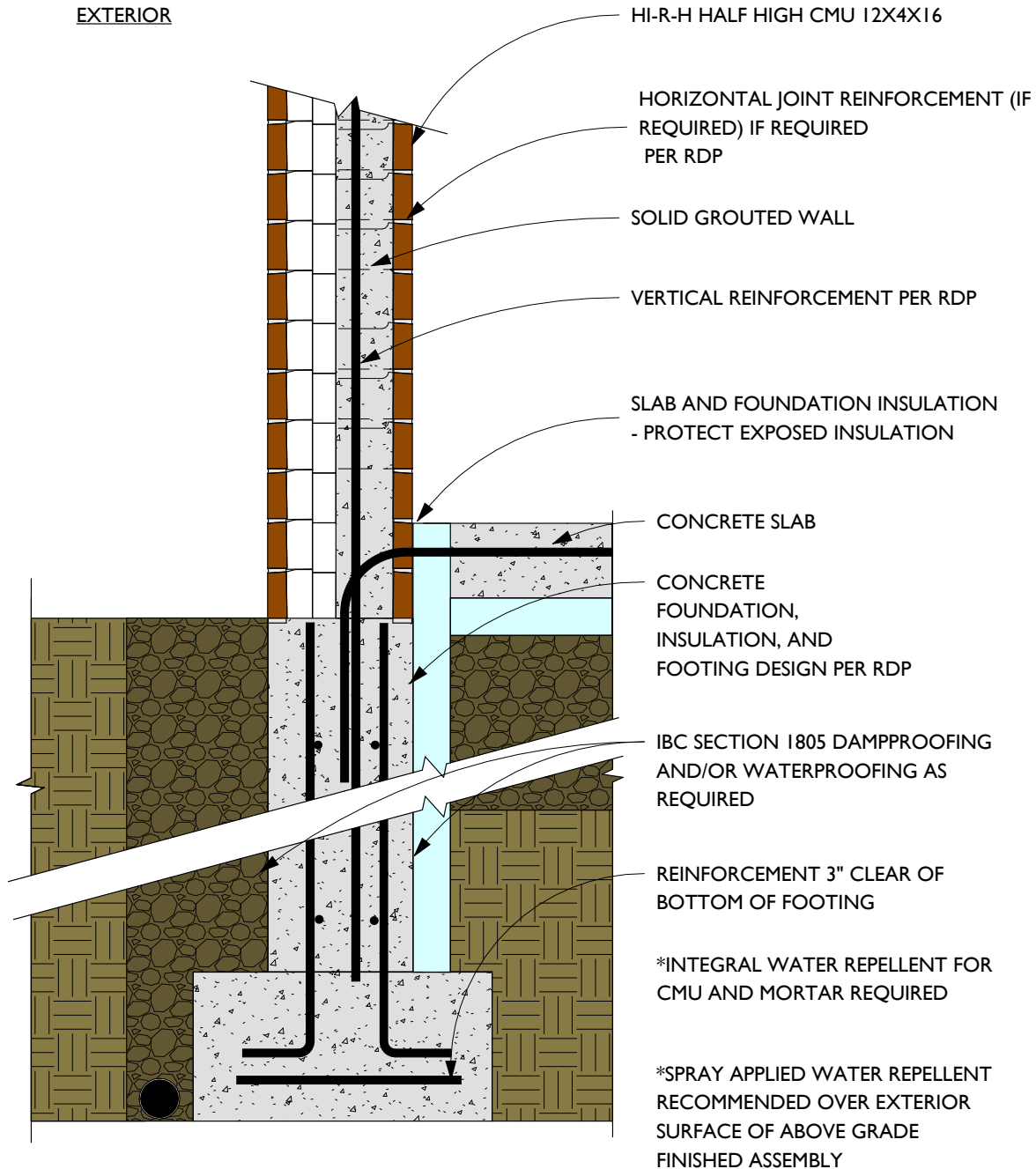

\*THIS DETAIL IS A STANDARD DETAIL. DESIGNERS SHOULD MAKE SITE SPECIFIC INVESTIGATIONS TO DETERMINE ACTUAL DESIGN REQUIREMENTS.

Detail 4-5002 - HI-R-H Half High - HI-R-H Foundation

EXTERIOR

INTERIOR

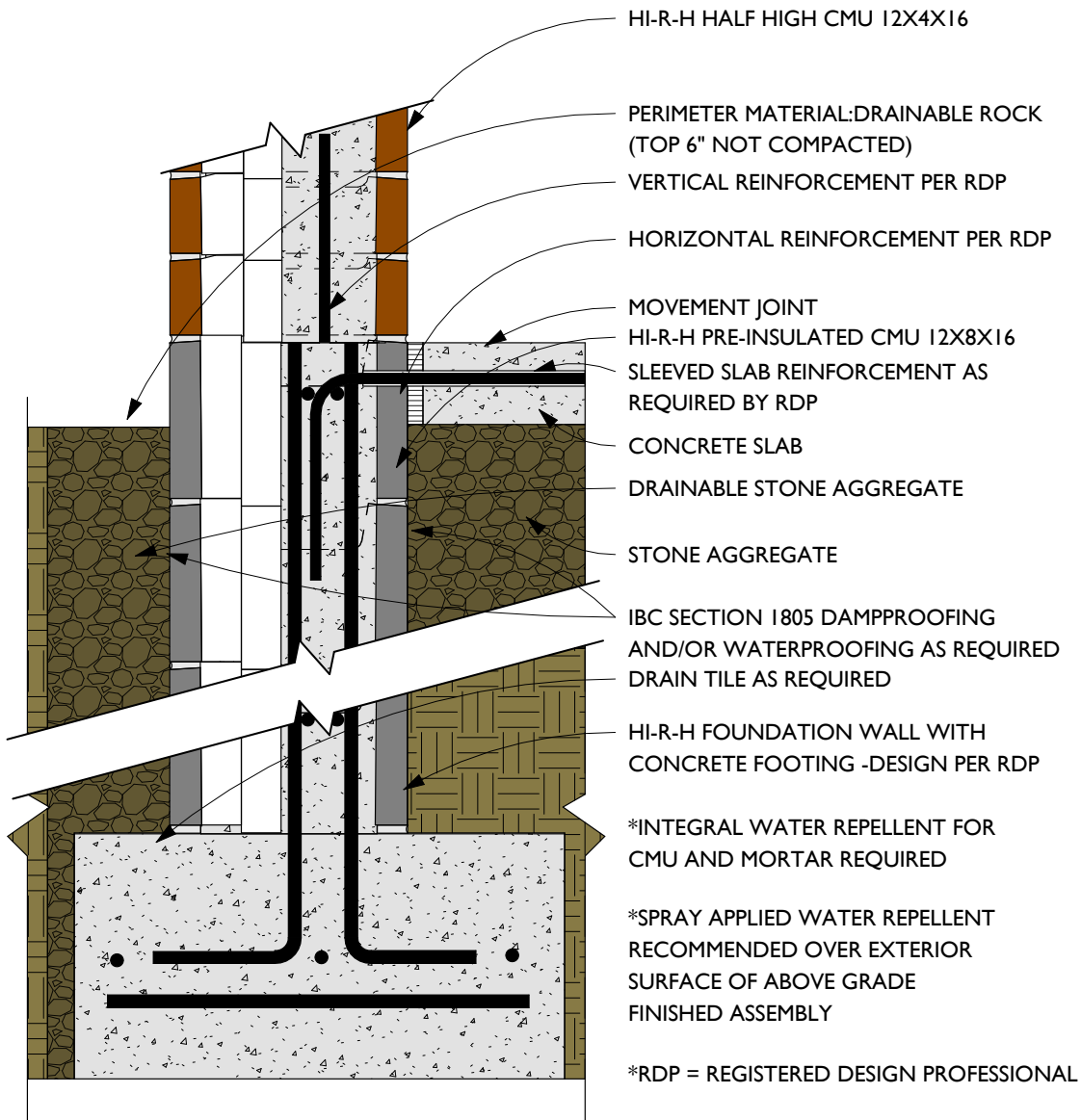

\*THIS DETAIL IS A STANDARD DETAIL. DESIGNERS SHOULD MAKE SITE SPECIFIC INVESTIGATIONS TO DETERMINE ACTUAL DESIGN REQUIREMENTS.

Detail 4-5003 - HI-R-H Half High - HI-R-H Foundation - Slab below grade

INTERIOR

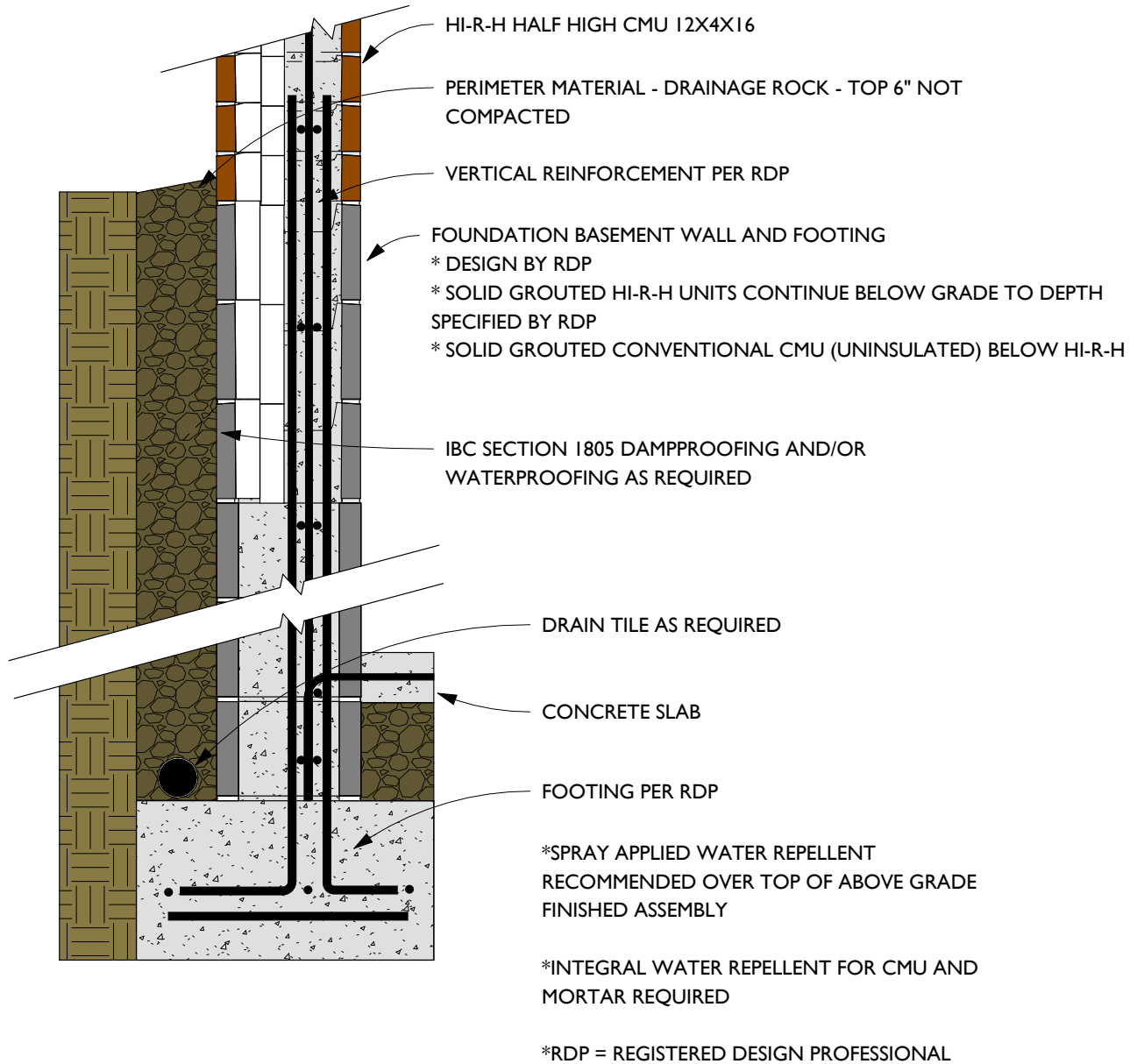

\*THIS DETAIL IS A STANDARD DETAIL. DESIGNERS SHOULD MAKE SITE SPECIFIC INVESTIGATIONS TO DETERMINE ACTUAL DESIGN REQUIREMENTS.

## Foundations – Additional Notes

1. In this manual, we present three choices for foundation wall construction: poured in place concrete, CMU, and pre-insulated CMU – Spec-Thermal® HI-R or HI-R-H. Each will meet structural requirements when properly designed. Both the concrete and traditional CMU footing/stem/crawl space/foundations will typically require insulation placement either to the exterior or interior (or both) of the foundation wall. The HI-R-H or HI-R foundation wall is pre-insulated with integral insulation in the unit and is fully grouted. Consult with Structural and/or Geo-technical Engineers for appropriate below-grade insulation material and placement.
2. Check local Code for slab insulation requirements – if the slab is on grade, address the thermal bridge at the slab by either placing interior or exterior insulation at this location. Insulation placed at the exterior will typically require some form of hardened protective covering. For insulation requirements see e.g., IECC/IRC Section R402.2.10/N1102.2.10 Slab-On-Grade Floors.
3. The use of pre-insulated block for the foundation and above grade walls provides a simple way to meet insulation requirements for both types of walls. It also has structural benefits as the foundation wall is fully supported directly by the engineered soils. Full grout should be used for the foundation wall. The insulation is protected integral insulation which eliminates damage concerns.
4. Generally a damp-check needs be placed above the top of the damp-proofing or waterproofing for foundation walls, basement walls, or foundations. For below-grade masonry basement walls an additional damp check at the masonry starting course and above the damp-proofing or waterproofing for slabs and floors will further control moisture. An above-grade masonry course with flashing also performs as a damp-check.
5. A tapered (30° from horizontal) 6" zone of free-draining gravel extending from the height of the finished floor to the top of the engineered soil may be substituted for the concrete apron shown.
6. To provide robust protection of above-grade single wythe walls from moisture penetration, we recommend integral water repellent (IWR) be used in both the block and mortar. The IWR in the block and mortar need to be chemically compatible (check with block manufacturer for recommendations). Some exceptions to using IWR may apply such as for California masonry core testing. To provide additional protection, we recommend use of a post-applied breathable water repellent over the finished wall after cleaning has been completed, cleaning results approved and the walls have completely dried.
7. If the zone near the above-grade wall or foundation wall is to be landscaped, do not place plant life, roots, irrigation, fertilizers or other chemicals within 3 feet of the above-grade wall or foundation wall. Isolate the above-grade wall, foundation wall, footing, foundation, and slab from such elements.
8. All details are available in Revit® and AutoCAD® – the numbering of the details in this manual corresponds to that used in the Revit® and AutoCAD® files.

Detail 4-5100 - HI-R-H Half High - Bond Beam

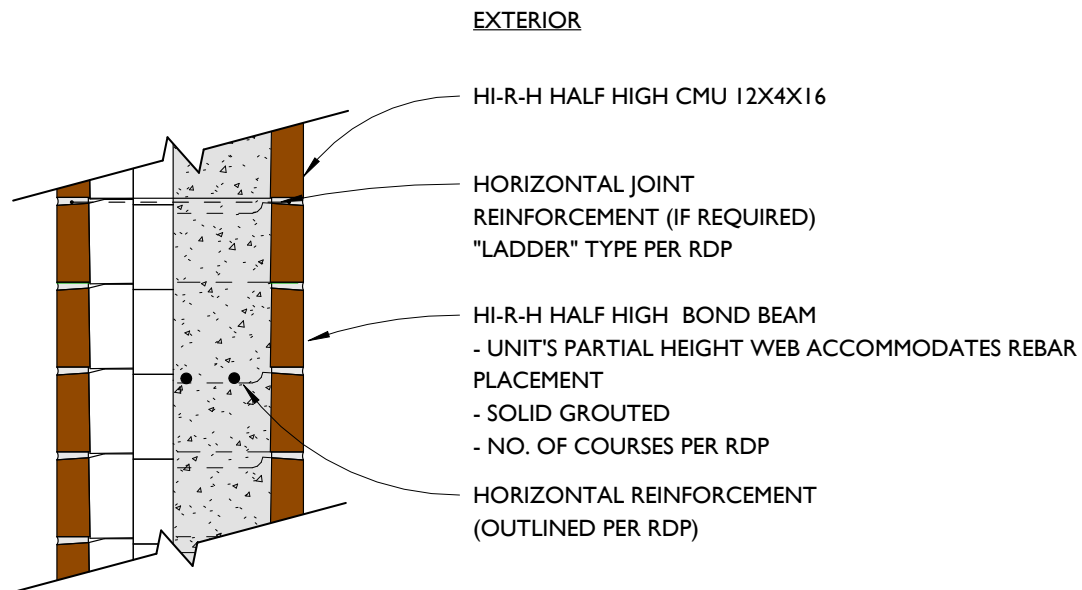

EXTERIOR

HI-R-H HALF HIGH CMU 12X4X16

HORIZONTAL JOINT  
REINFORCEMENT (IF REQUIRED)  
"LADDER" TYPE PER RDP

HI-R-H HALF HIGH BOND BEAM  
- UNIT'S PARTIAL HEIGHT WEB ACCOMMODATES REBAR  
PLACEMENT  
- SOLID GROUTED  
- NO. OF COURSES PER RDP

HORIZONTAL REINFORCEMENT  
(OUTLINED PER RDP)

\*INTEGRAL WATER REPELLENT FOR CMU AND  
MORTAR REQUIRED

\*SPRAY APPLIED WATER REPELLENT  
RECOMMENDED OVER TOP OF FINISHED  
ASSEMBLY

\*RDP = REGISTERED DESIGN PROFESSIONAL

\*THIS DETAIL IS A STANDARD DETAIL. DESIGNERS SHOULD MAKE SITE SPECIFIC INVESTIGATIONS TO DETERMINE ACTUAL DESIGN REQUIREMENTS.

## Horizontal Joint Reinforcement

### Detail 4-5101 - HI-R-H Half High - Horizontal Joint Reinforcement

EXTERIOR

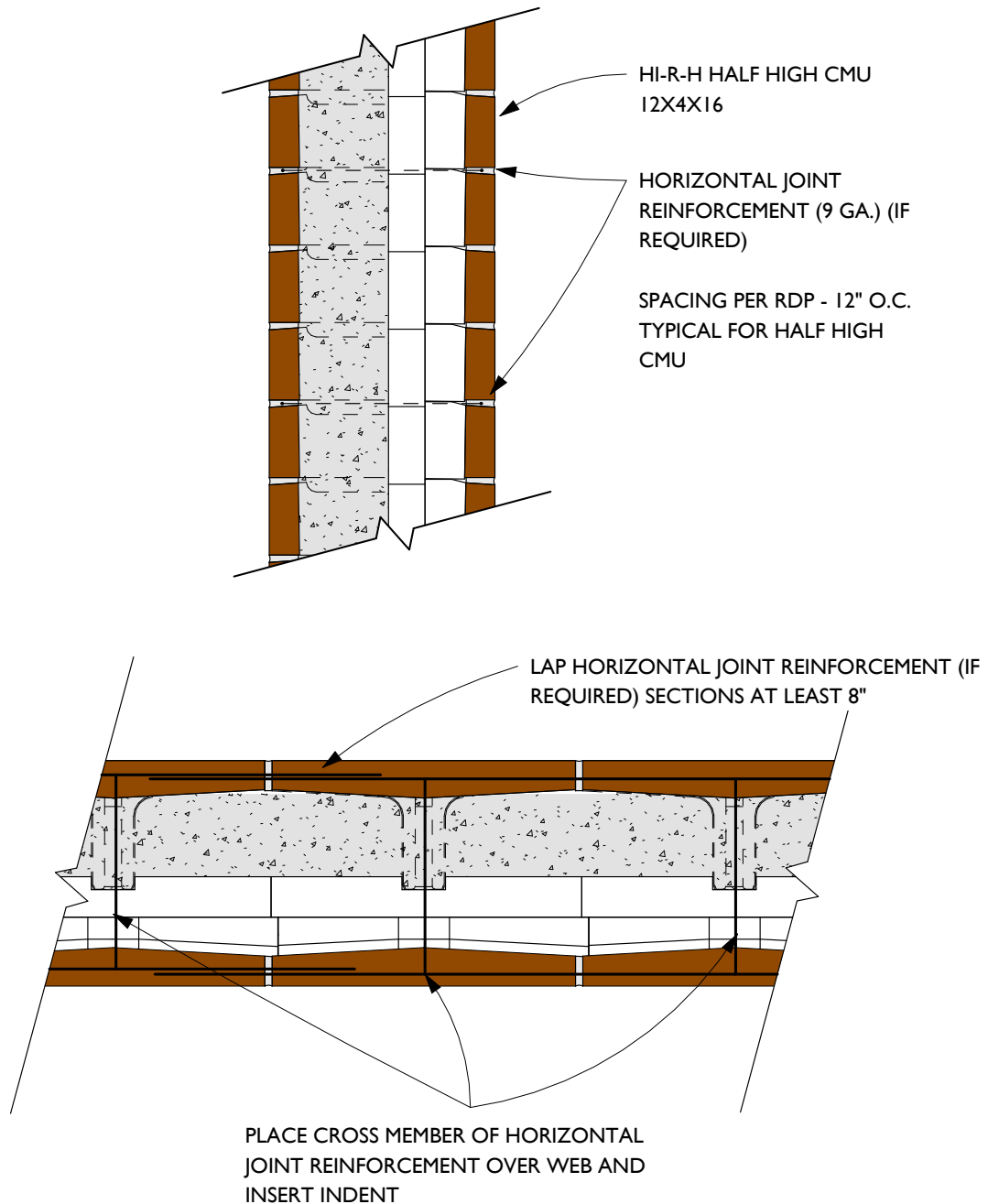

\*THIS DETAIL IS A STANDARD DETAIL. DESIGNERS SHOULD MAKE SITE SPECIFIC INVESTIGATIONS TO DETERMINE ACTUAL DESIGN REQUIREMENTS.

Control Joint

Detail 4-5109- HI-R-H Half High – Piers, Control Joint and Jamb

COURSE 1

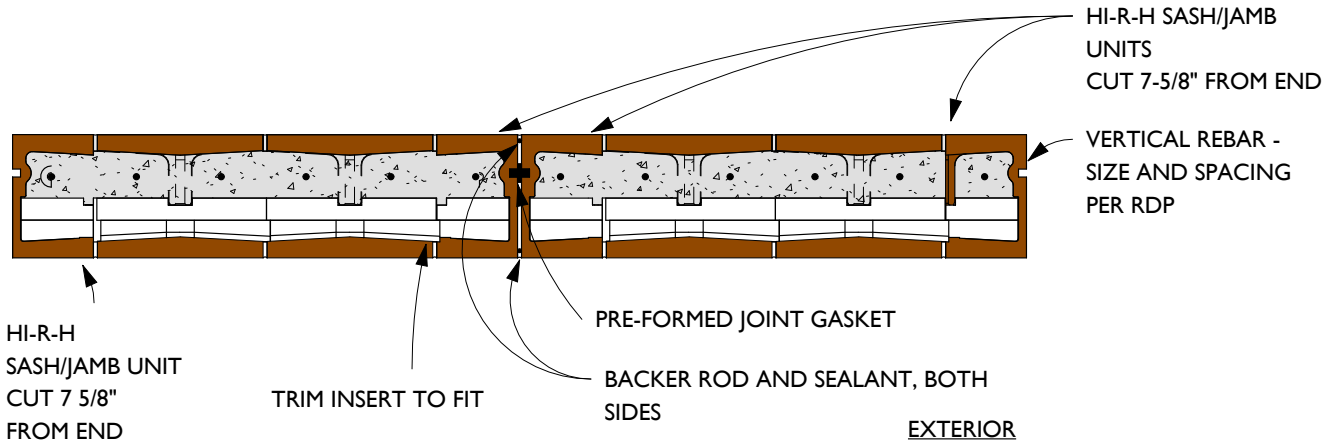

COURSE 2

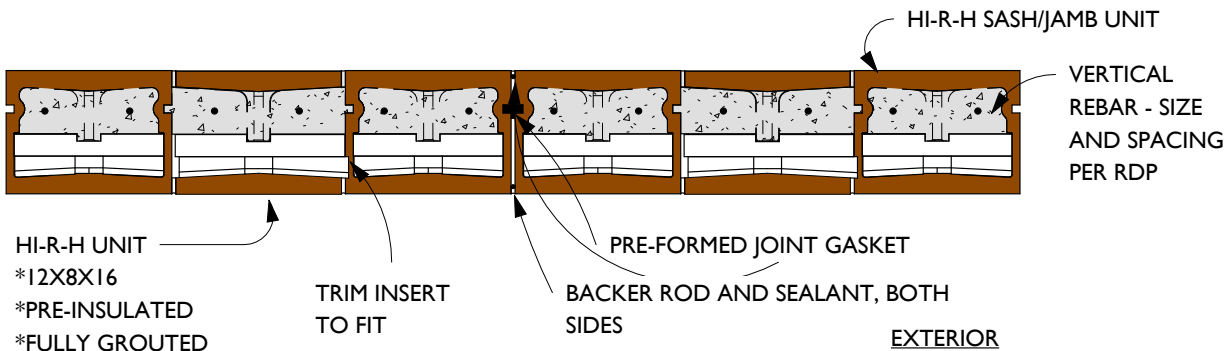

PLEASE CONFIRM LOCAL AVAILABILITY OF HI-R-H SASH/JAMB UNIT PRIOR TO SPECIFYING

\*THIS DETAIL IS A STANDARD DETAIL. DESIGNERS SHOULD MAKE SITE SPECIFIC INVESTIGATIONS TO DETERMINE ACTUAL DESIGN REQUIREMENTS.

Control Joint

Detail 4-5110- HI-R-H Half High – Piers, Control Joint and Jamb -Hooked Rein.

COURSE 1

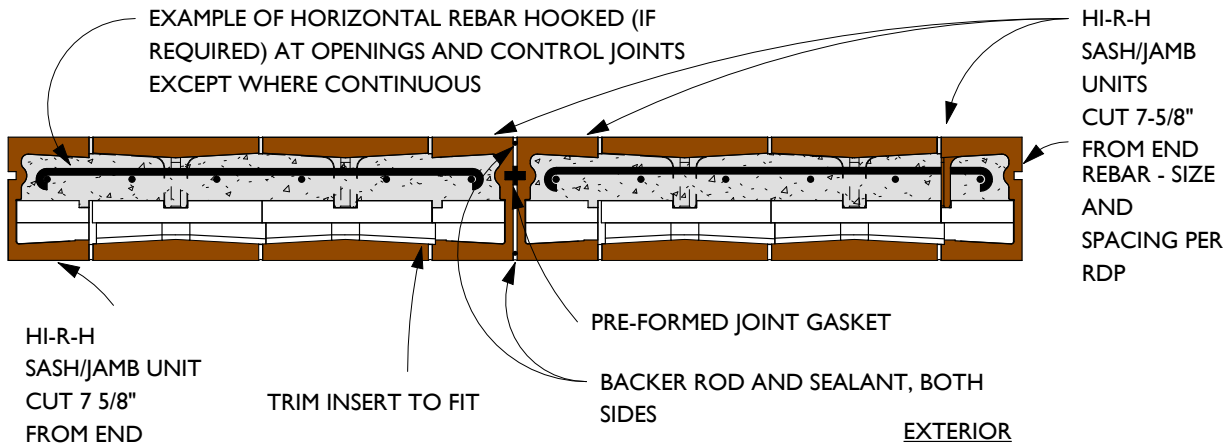

COURSE 2

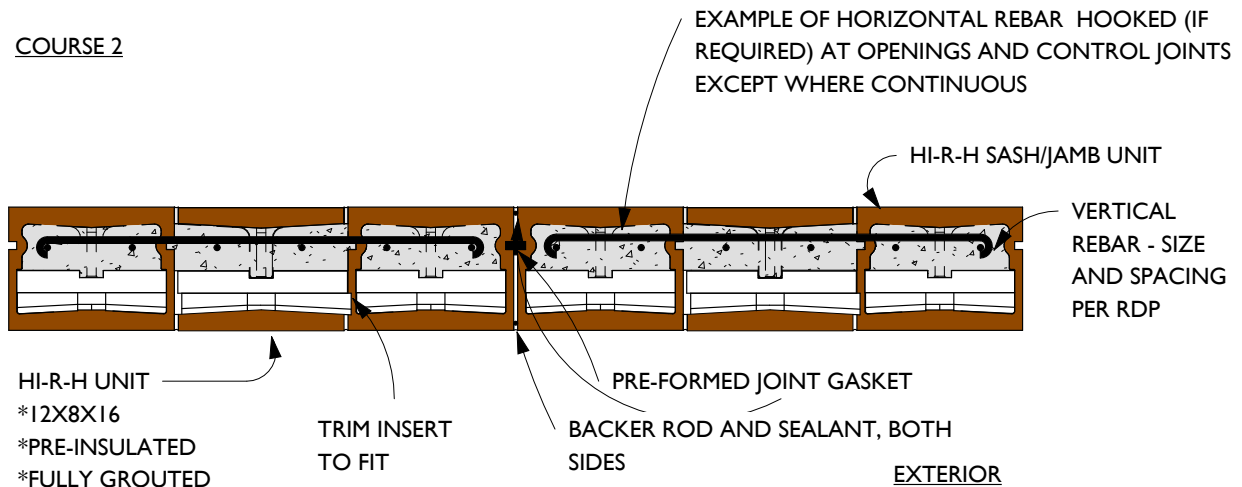

PLEASE CONFIRM LOCAL AVAILABILITY OF HI-R-H SASH/JAMB UNIT PRIOR TO SPECIFYING

\*THIS DETAIL IS A STANDARD DETAIL. DESIGNERS SHOULD MAKE SITE SPECIFIC INVESTIGATIONS TO DETERMINE ACTUAL DESIGN REQUIREMENTS.

Control Joint

Detail 4-5111 - HI-R-H Half High - Control Joint - CMU Sash

EXTERIOR

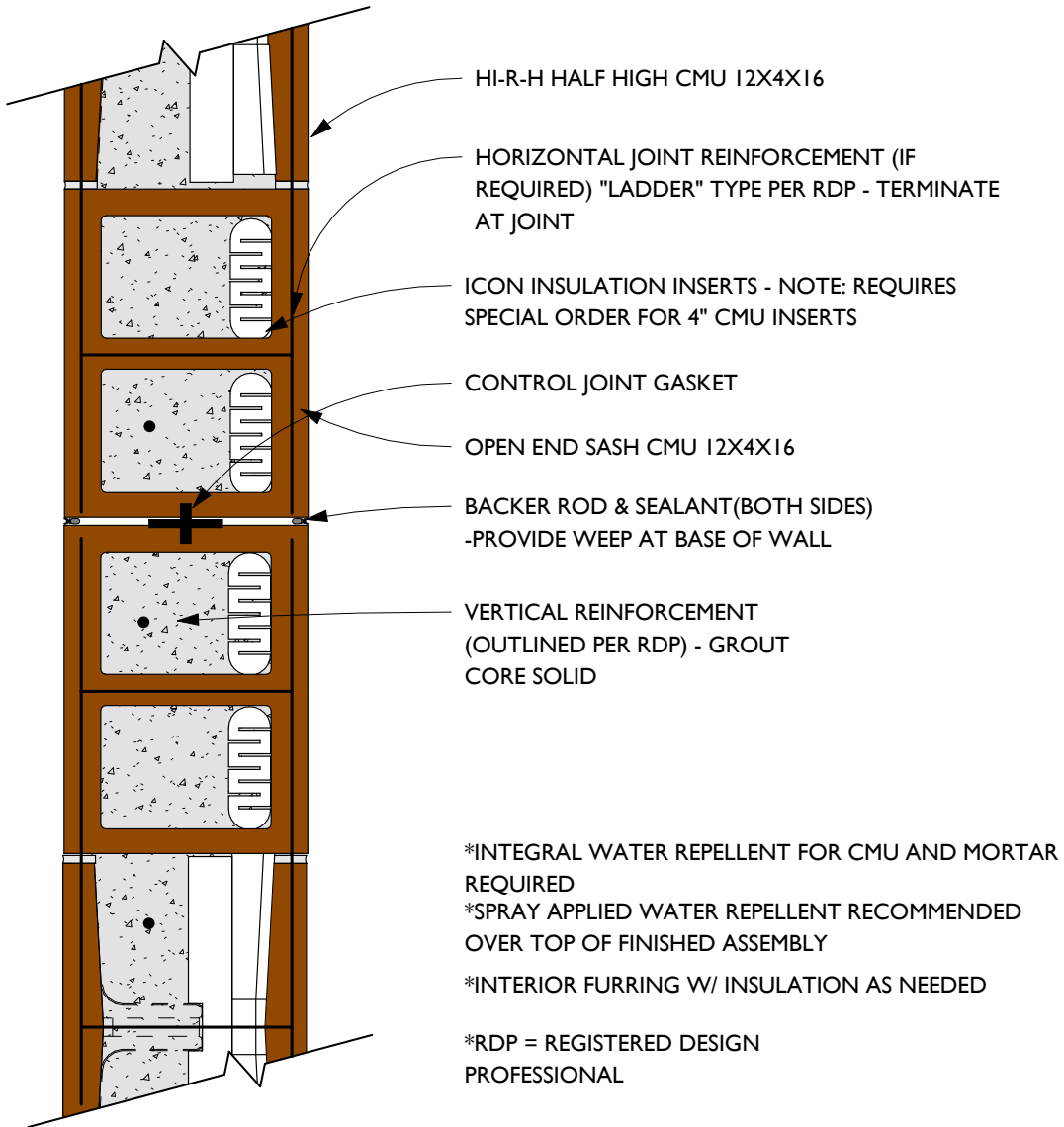

\*THIS DETAIL IS A STANDARD DETAIL. DESIGNERS SHOULD MAKE SITE SPECIFIC INVESTIGATIONS TO DETERMINE ACTUAL DESIGN REQUIREMENTS.

Control Joint

Detail 4-5112 - HI-R-H Half High - Control Joint - HI-R-H Half High Sash/Jamb Unit

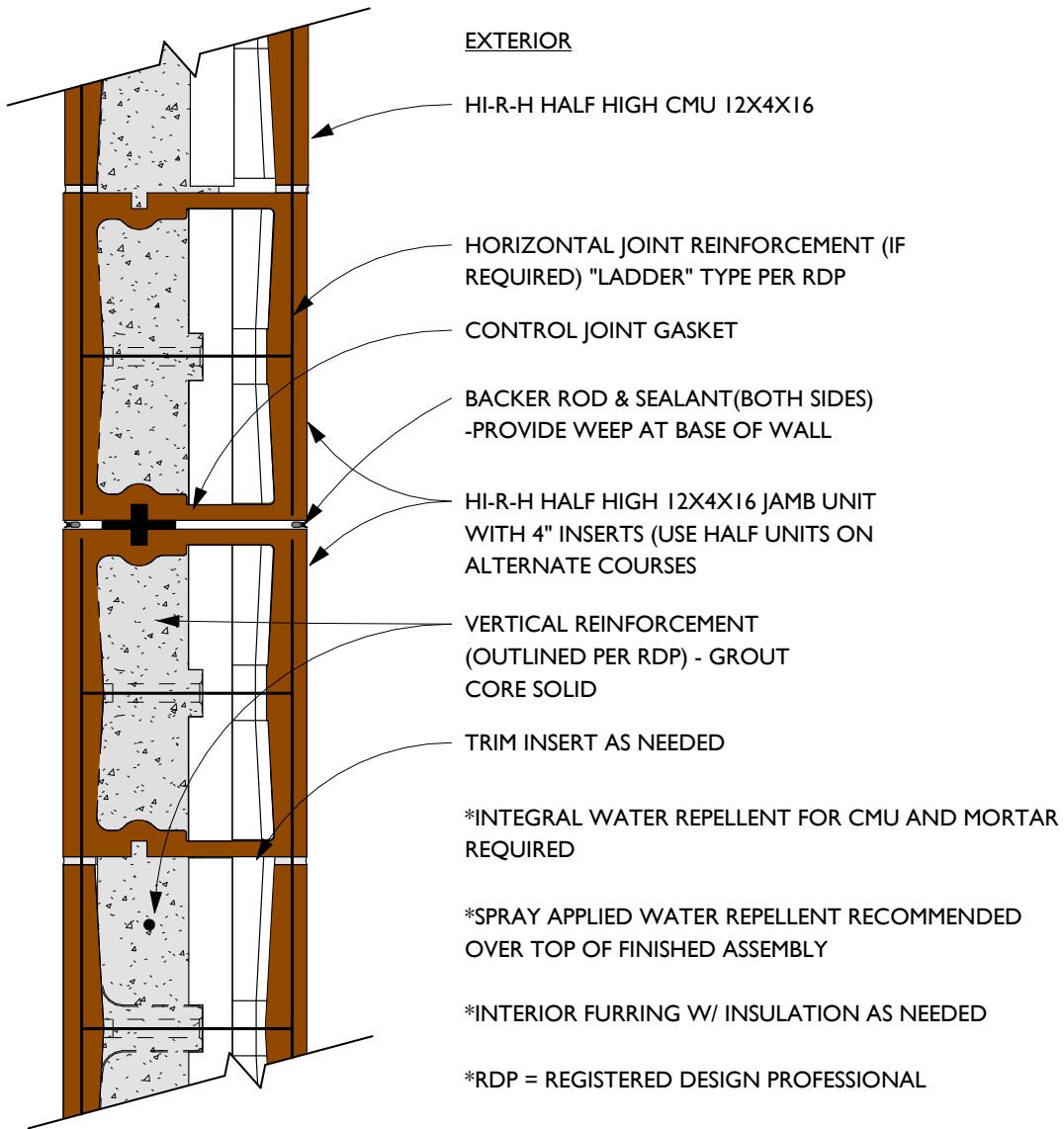

NOTE: CHECK ON REGIONAL AVAILABILITY OF HI-R-H HALF HIGH SASH/JAMB UNIT BEFORE SPECIFYING

\*THIS DETAIL IS A STANDARD DETAIL. DESIGNERS SHOULD MAKE SITE SPECIFIC INVESTIGATIONS TO DETERMINE ACTUAL DESIGN REQUIREMENTS.

**Additional Notes – Bond Beams and Joints:**

1. For half high units, the CMHA (formerly NCMA) recommends aesthetic crack control horizontal joint reinforcement be placed at 12" O.C. vertically.
2. Bond beams are typically built using HI-R-H Half High units without the need for any modifications due to the unit's reduced web height.
3. The HI-R-H Half High system is designed to accommodate 9 ga. ladder type horizontal joint reinforcement. The insulation inserts have a slight indentation that aligns with the unit webs. HJR should be placed with the cross rods located at these indentations and block webs. 16" spacing of the cross rods is typical.
4. Control joints are a method to assist in controlling cracking in concrete masonry walls by allowing discrete panels in the field of a larger wall to accommodate shrinkage. There are a variety of methods to construct a control joint.
5. There are a variety of construction joints with differing names and purposes (and consistency of usage has been an issue). The joints shown in this manual are used with these meanings:
  - **Control Joint** – A joint used to break up a large field of concrete masonry into discrete panels for the purpose of allowing shrinkage and mitigating cracking.
  - **Movement Joint** – A generic term for a joint that may be intended to serve in multiple functions or accommodate multiple sources of movement.
  - **Relief Joint** – A weakened section of reinforced concrete masonry used to control and isolate the formation of shrinkage related cracks.
6. Though not depicted here, another important use for joints is in areas where there are interfaces between materials that may have different expansion properties. One example would be placing a section of clay brick (tends to expand over time) above or below a section of concrete masonry (tends to shrink over time) in a wall. Placing a joint between the differing materials will accommodate any slight differential in expansion/contraction properties.
7. In general, the specific spacing and placement of control joints for a project should be reviewed by the project structural engineer who can design the joint spacing in the most efficient manner. Refer to the CMHA (formerly NCMA) TEK notes for required horizontal reinforcement for crack control based on upon joint sizes and locations selected by RDP. Horizontal reinforcement can be provided by either use of horizontal joint reinforcement or horizontal reinforcing rebar.
8. For best results, **remember masonry modularity when placing joints (also true for designing the length and height for walls and the size and placement of openings)** This means these locations should be in multiples of 8 inches from the end of the wall. Designing with modularity in mind will result in optimal efficiency when the wall is built, because if the dimensions are not consistent with masonry modularity then the mason contractor will have to cut units in the field to fit the design.

## Corners

### Detail 4-5120 - HI-R-H Half High - Corner - CMU Fitting - Course 1

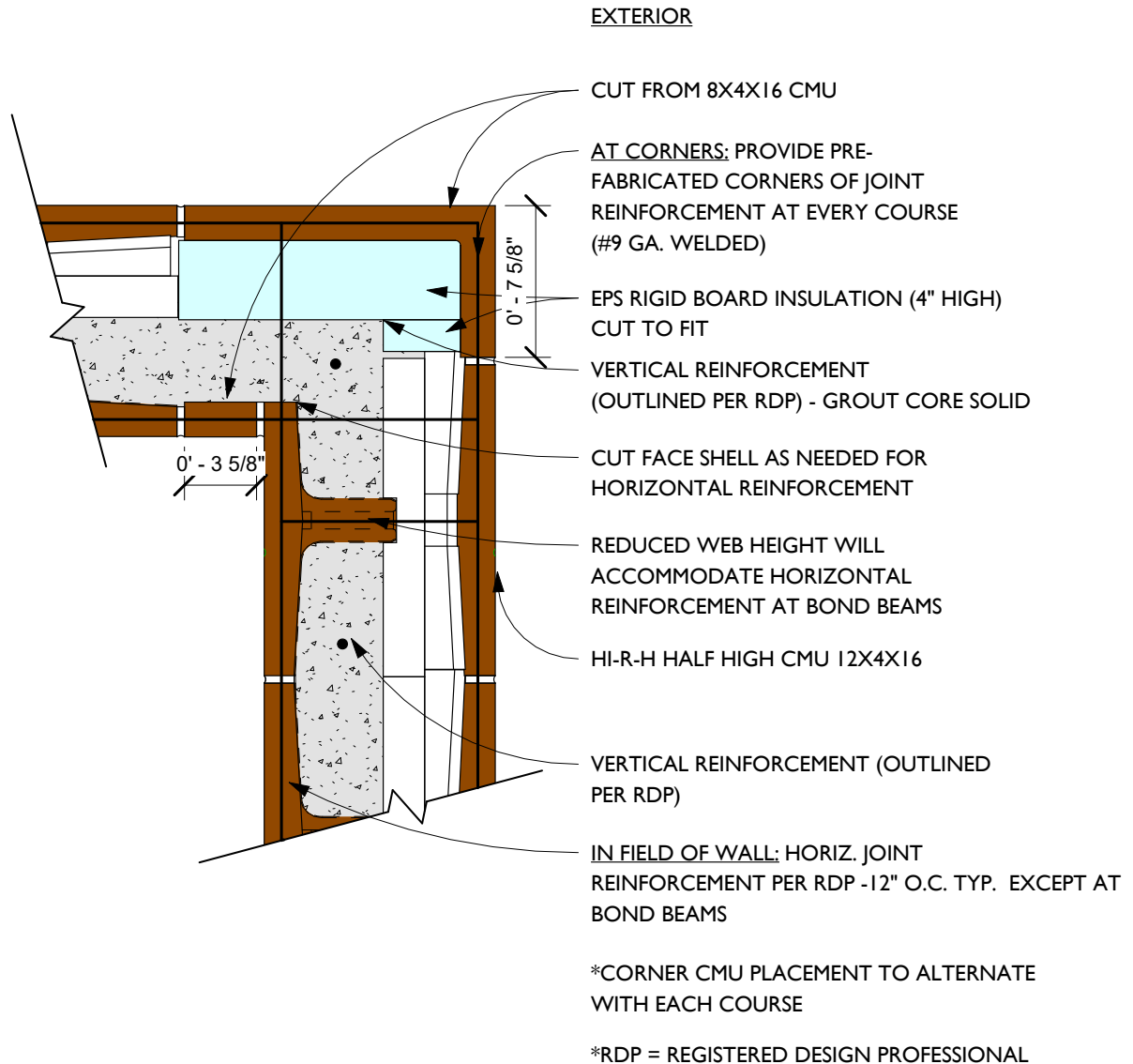

\*THIS DETAIL IS A STANDARD DETAIL. DESIGNERS SHOULD MAKE SITE SPECIFIC INVESTIGATIONS TO DETERMINE ACTUAL DESIGN REQUIREMENTS.

**Corners**

**Detail 4-5121 - HI-R-H Half High - Corner - CMU Fitting - Course 2**

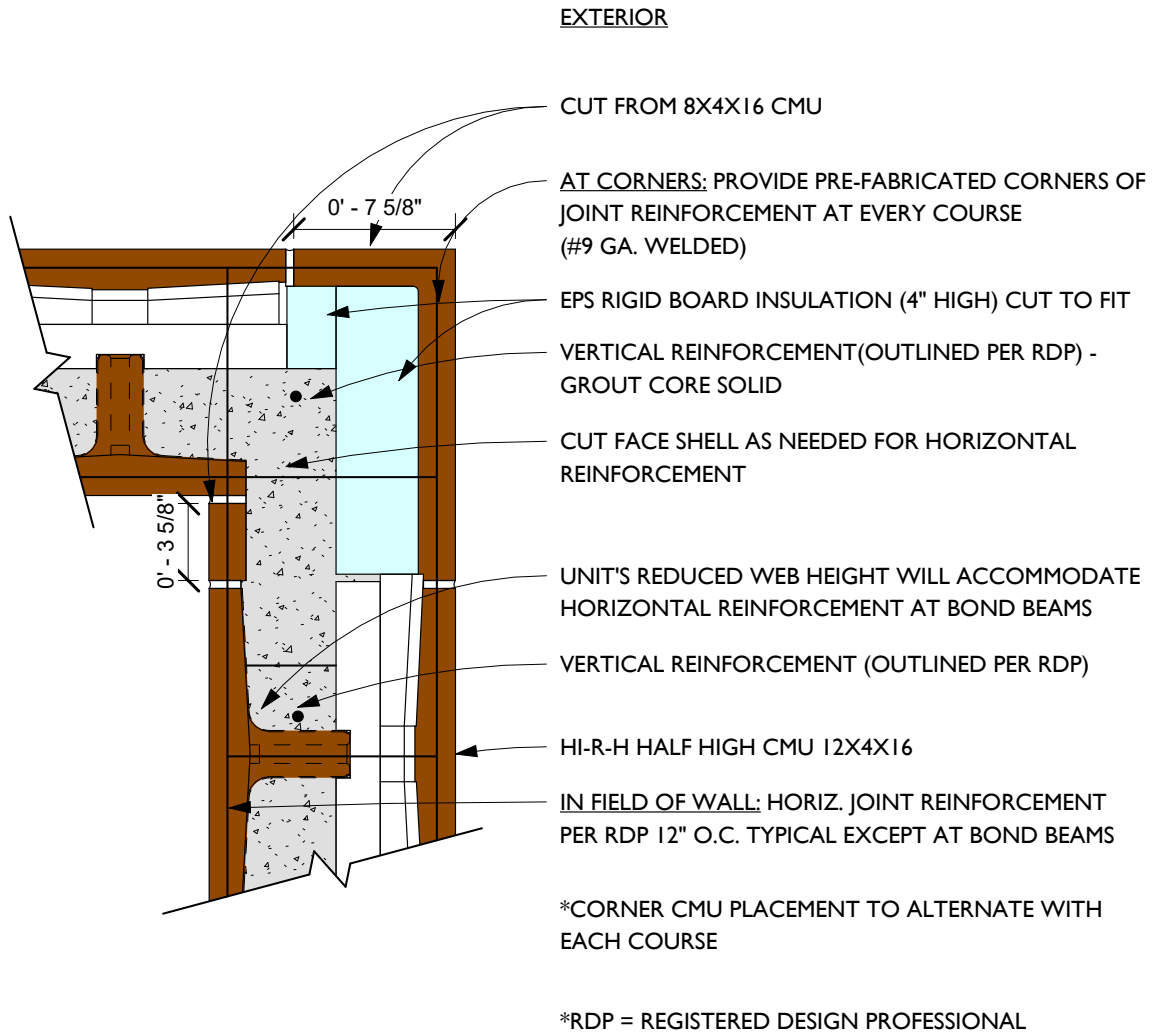

\*THIS DETAIL IS A STANDARD DETAIL. DESIGNERS SHOULD MAKE SITE SPECIFIC INVESTIGATIONS TO DETERMINE ACTUAL DESIGN REQUIREMENTS.

Corners

Detail 4-5122 - HI-R-H Half High - Corner - 12X8X16 HI-R-H and CMU Fitting (unit cuts)

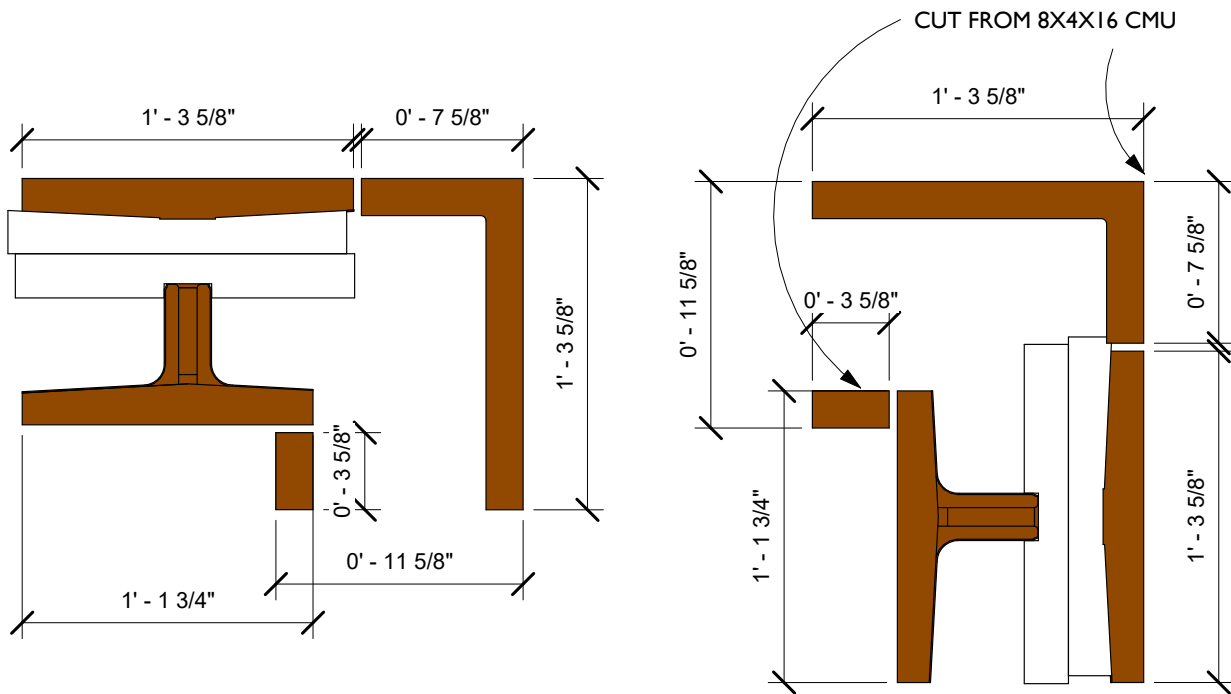

\*THIS DETAIL IS A STANDARD DETAIL. DESIGNERS SHOULD MAKE SITE SPECIFIC INVESTIGATIONS TO DETERMINE ACTUAL DESIGN REQUIREMENTS.

**Additional Notes – Corners:**

1. The use of an L-Shaped fitting and a soap cut from an 8X8X16 CMU has proven to a popular choice for building corners. Another method uses the HI-R-H Half High Jamb Unit cut for a corner. Of the two, the L-Shaped corner is generally preferred for ease of installation.
2. The EPS corner pieces should be at least as thick as the HI-R insulation inserts to provide insulation as good or better than the HI-R-H units.
3. All details are available in Revit® and AutoCAD® – the numbering of the details in this manual corresponds to that used in the Revit® and AutoCAD® files.

## Window Opening - Lintels

### Detail 4-5200 - HI-R-H Half High - Window Head & Lintel with HI-R-H Half High Unit

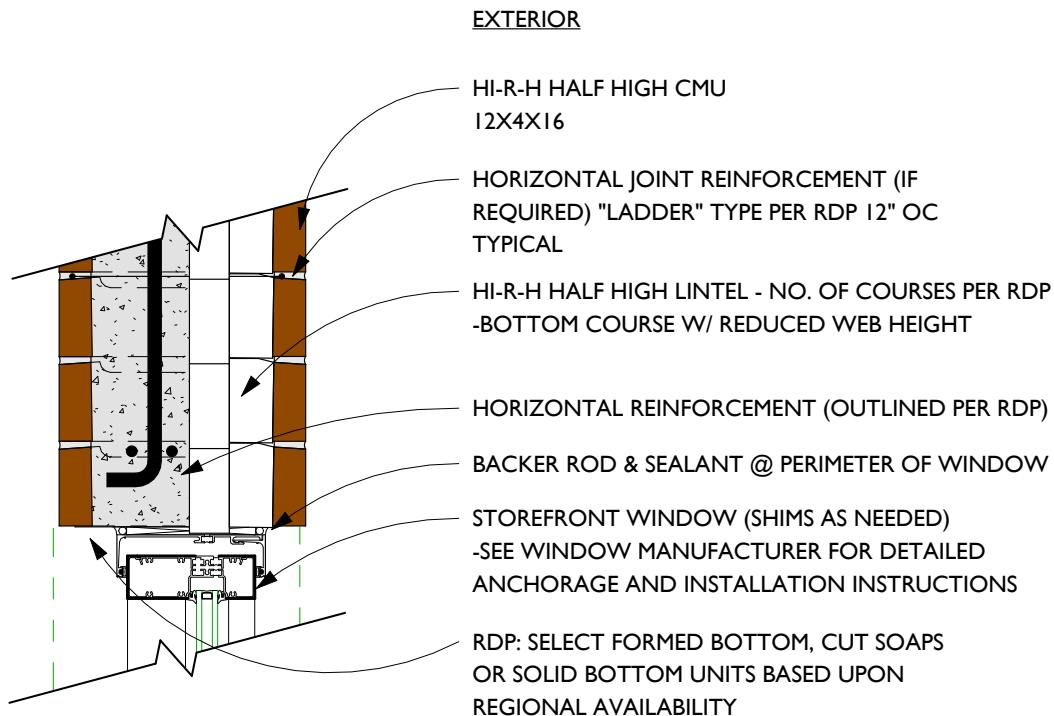

\*INTEGRAL WATER REPELLENT FOR CMU  
AND MORTAR REQUIRED

\*SPRAY APPLIED WATER REPELLENT  
RECOMMENDED OVER TOP OF FINISHED  
ASSEMBLY

\*RDP = REGISTERED DESIGN  
PROFESSIONAL

\*THIS DETAIL IS A STANDARD DETAIL. DESIGNERS SHOULD MAKE SITE SPECIFIC INVESTIGATIONS TO DETERMINE ACTUAL DESIGN REQUIREMENTS.

## Window Opening – Lintels

### Detail 4-5201 – HI-R-H Half High – Window Head & Lintel with HI-R/HI-R-H Closed Bottom Lintel Unit

PLEASE CONFIRM  
LOCAL AVAILABILITY  
OF HI-R/HI-R-H CLOSED BOTTOM LINTEL  
PRIOR TO SPECIFYING

EXTERIOR

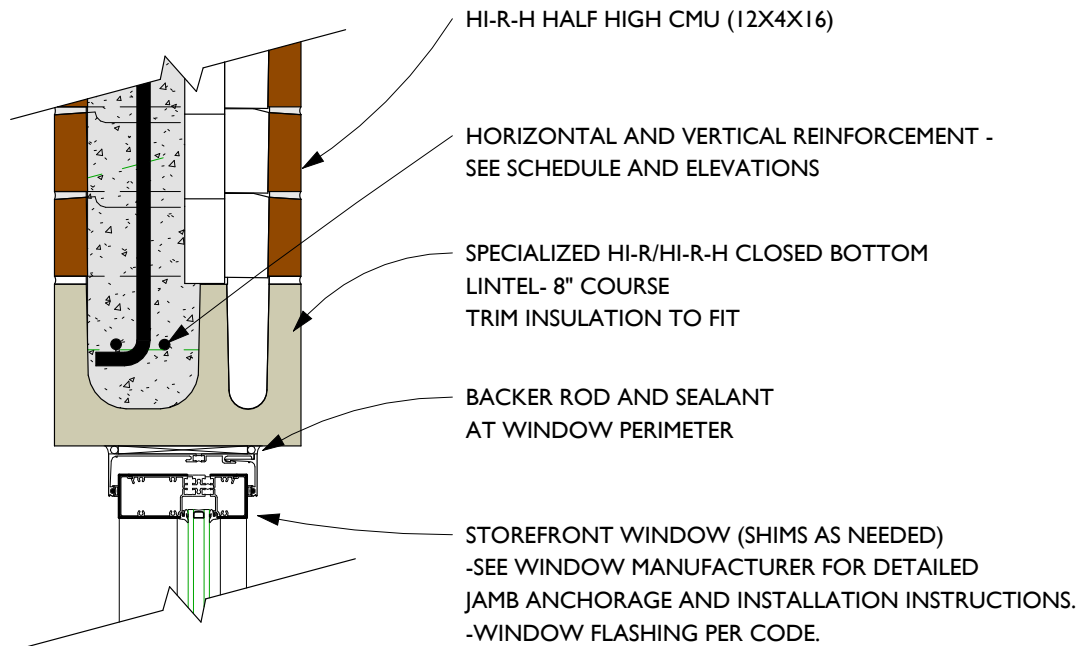

\*RDP = REGISTERED DESIGN PROFESSIONAL

\*INTEGRAL WATER REPELLENT FOR CMU  
AND MORTAR REQUIRED

\*SPRAY APPLIED WATER REPELLENT  
RECOMMENDED OVER TOP OF FINISHED  
ASSEMBLY

\*THIS DETAIL IS A STANDARD DETAIL. DESIGNERS SHOULD MAKE SITE SPECIFIC INVESTIGATIONS TO DETERMINE ACTUAL DESIGN REQUIREMENTS.

## Window Openings - Jamb

### Detail 4-5202 - HI-R-H Half High - Window Jamb with CMU Jamb

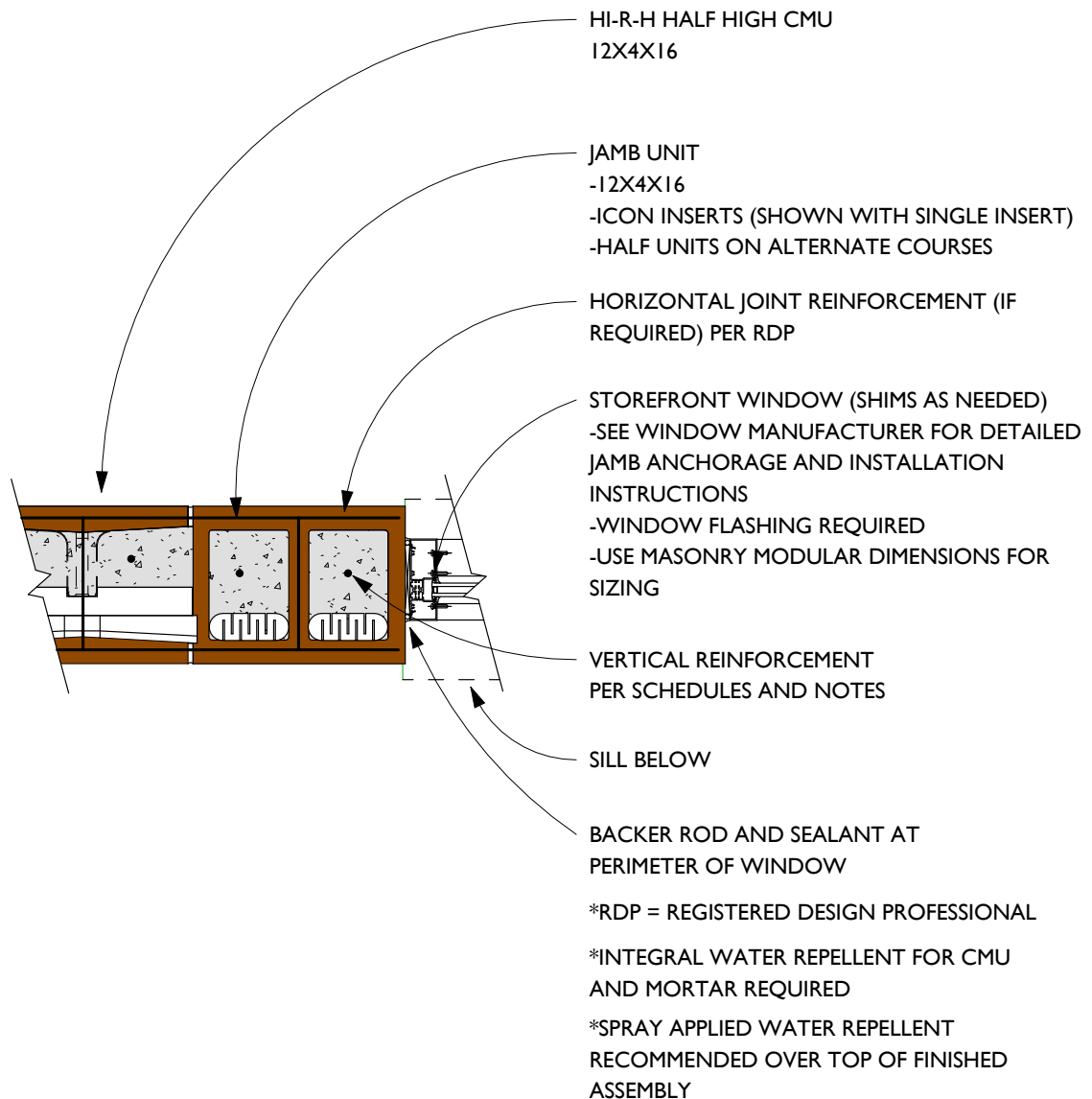

\*THIS DETAIL IS A STANDARD DETAIL. DESIGNERS SHOULD MAKE SITE SPECIFIC INVESTIGATIONS TO DETERMINE ACTUAL DESIGN REQUIREMENTS.

**Window Openings - Jamb**

**Detail 4-5203 - HI-R-H Half High - Window Jamb with HI-R-H Half High Sash/Jamb Unit**

PLEASE CONFIRM LOCAL AVAILABILITY OF HI-R-H HALF HIGH SASH/JAMB UNIT BEFORE SPECIFYING

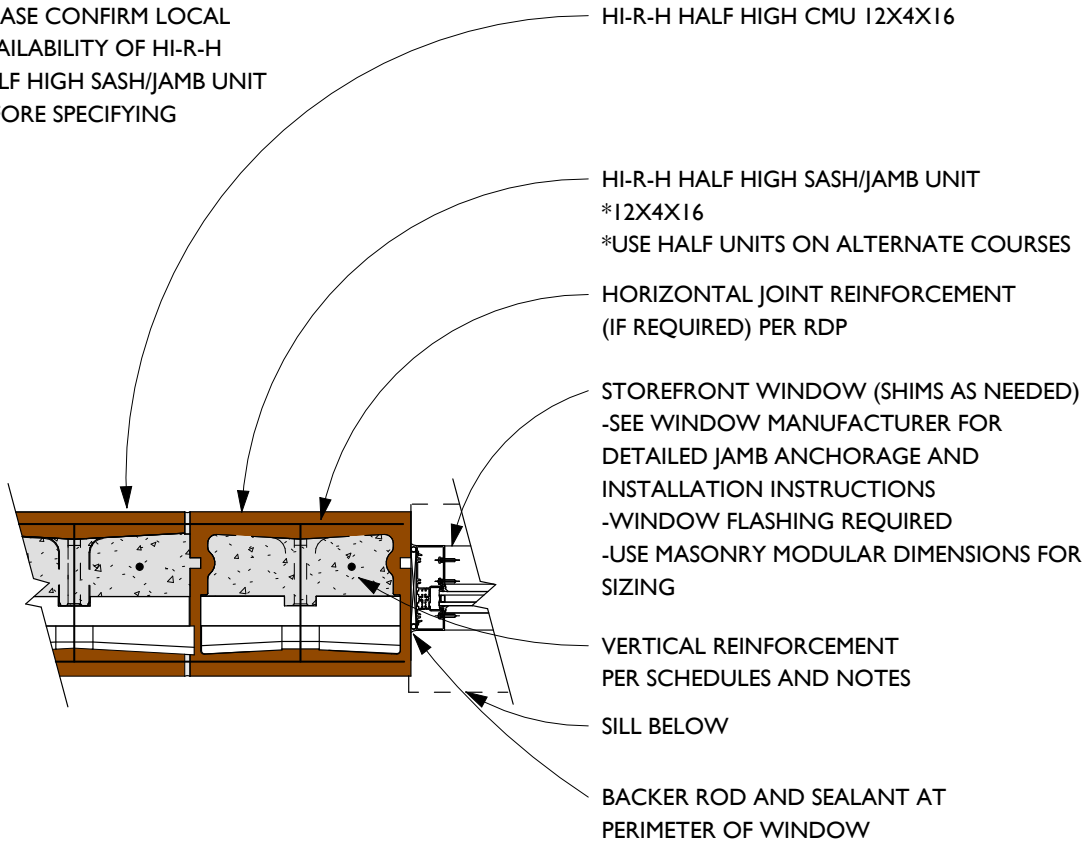

HI-R-H HALF HIGH CMU 12X4X16

HI-R-H HALF HIGH SASH/JAMB UNIT  
\*12X4X16  
\*USE HALF UNITS ON ALTERNATE COURSES

HORIZONTAL JOINT REINFORCEMENT  
(IF REQUIRED) PER RDP

STOREFRONT WINDOW (SHIMS AS NEEDED)  
-SEE WINDOW MANUFACTURER FOR DETAILED JAMB ANCHORAGE AND INSTALLATION INSTRUCTIONS  
-WINDOW FLASHING REQUIRED  
-USE MASONRY MODULAR DIMENSIONS FOR SIZING

VERTICAL REINFORCEMENT  
PER SCHEDULES AND NOTES

SILL BELOW

BACKER ROD AND SEALANT AT PERIMETER OF WINDOW

NOTE: IF NECESSARY, HALF JAMB UNITS MAY BE FLIPPED TO ALLOW USE OF LEFT OR RIGHT HALF UNITS INTERCHANGEABLY. FLIP SO THAT LOCATION OF SASH LINES UP WHEN PLACED. TAKE CARE WITH COURSE HEIGHT IF THIS IS DONE.

\*RDP = REGISTERED DESIGN PROFESSIONAL

\*INTEGRAL WATER REPELLENT FOR CMU AND MORTAR REQUIRED

\*SPRAY APPLIED WATER REPELLENT RECOMMENDED OVER TOP OF FINISHED ASSEMBLY

\*THIS DETAIL IS A STANDARD DETAIL. DESIGNERS SHOULD MAKE SITE SPECIFIC INVESTIGATIONS TO DETERMINE ACTUAL DESIGN REQUIREMENTS.

Detail 4-5204 - HI-R-H Half High - Window Sill - 4" Sill Unit

EXTERIOR

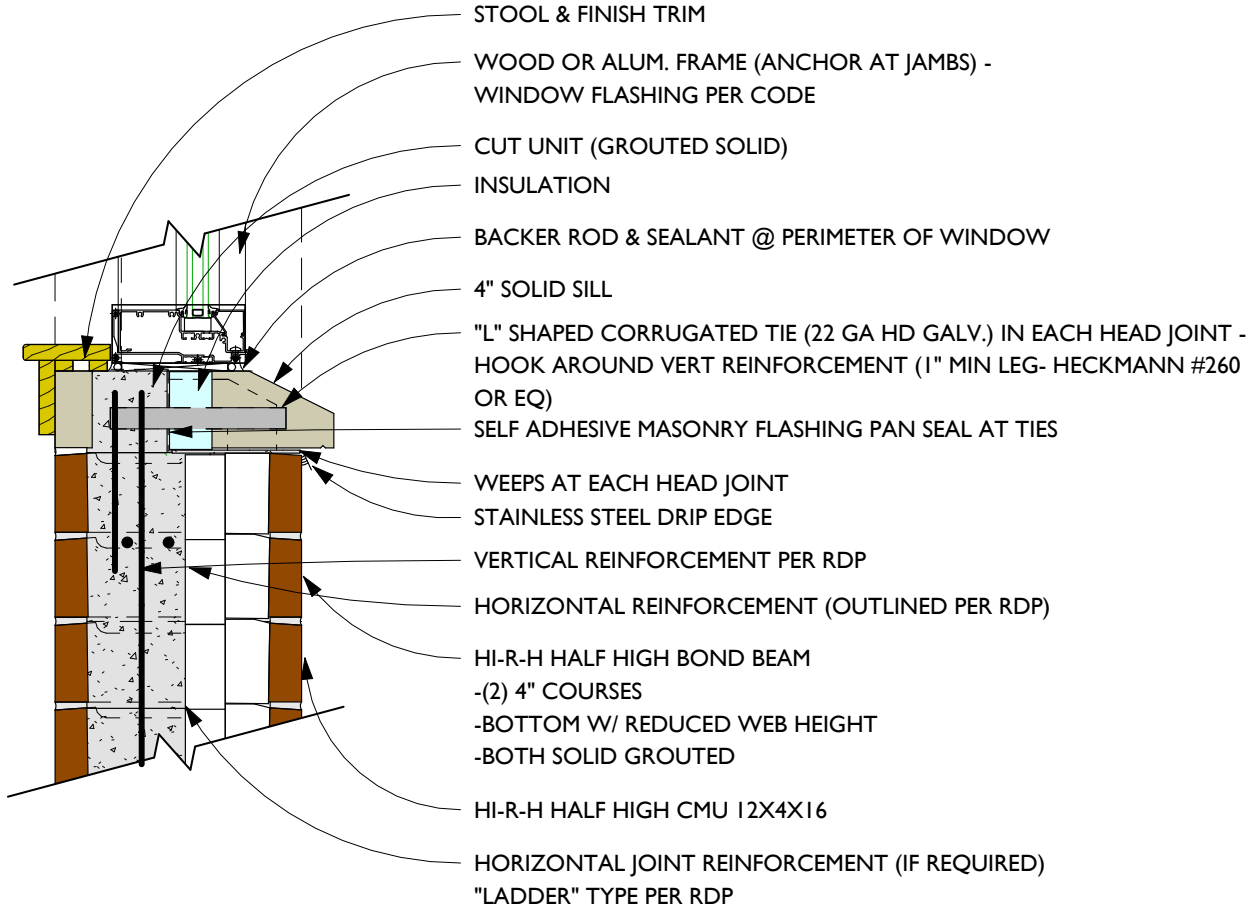

\*INTEGRAL WATER REPELLENT FOR CMU AND MORTAR REQUIRED

\*SPRAY APPLIED WATER REPELLENT RECOMMENDED OVER TOP OF FINISHED ASSEMBLY

\*RDP = REGISTERED DESIGN PROFESSIONAL

\*THIS DETAIL IS A STANDARD DETAIL. DESIGNERS SHOULD MAKE SITE SPECIFIC INVESTIGATIONS TO DETERMINE ACTUAL DESIGN REQUIREMENTS.

Detail 4-5205 – HI-R-H Half High – Window Sill – 8" Sill Unit

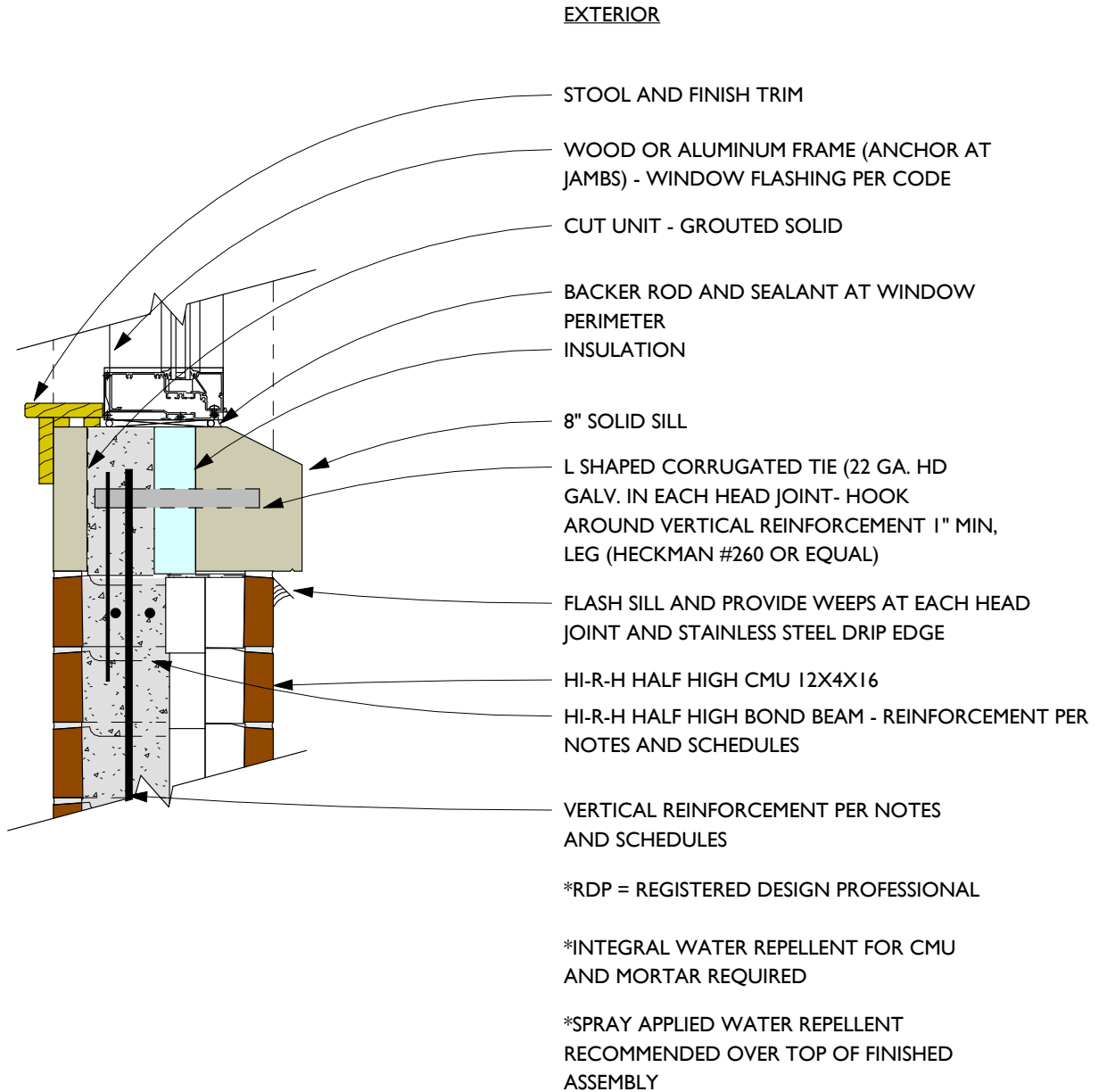

\*THIS DETAIL IS A STANDARD DETAIL. DESIGNERS SHOULD MAKE SITE SPECIFIC INVESTIGATIONS TO DETERMINE ACTUAL DESIGN REQUIREMENTS.

**Additional Notes – Window openings:**

1. Lintel may either be formed from HI-R-H Half High units (see notes regarding bond beams) or by using a specialized insulated HI-R/HI-R-H closed bottom lintel unit. This unit (available in 12X8X16 only) is only available in certain regions, so please check first before specifying. Lintel formed from HI-R units will require a surface treatment such as parging or finish trim since the lintel is open bottomed and the grout and inserts may be revealed without a finish treatment.
2. Jambs are typically formed using a CMU jamb unit with Icon® inserts or by using a HI-R-H half high jamb unit that is regionally available. Icon® inserts are standardly manufactured for 8" high block, and need to be special ordered to be cut for use with 4" high block. The thermal properties of the jamb should be considered when performing Energy Code compliance calculations.
3. We show an insulated Window sill – choose rigid board insulation with sufficient thickness to meet requirements.
4. All details are available in Revit® and AutoCAD® – the numbering of the details in this manual corresponds to that used in the Revit® and AutoCAD® files.

## Door Openings – Lintel

### Detail 4-5210 – HI-R-H Half High – Door Head and Lintel Using HI-R-H Half High Units

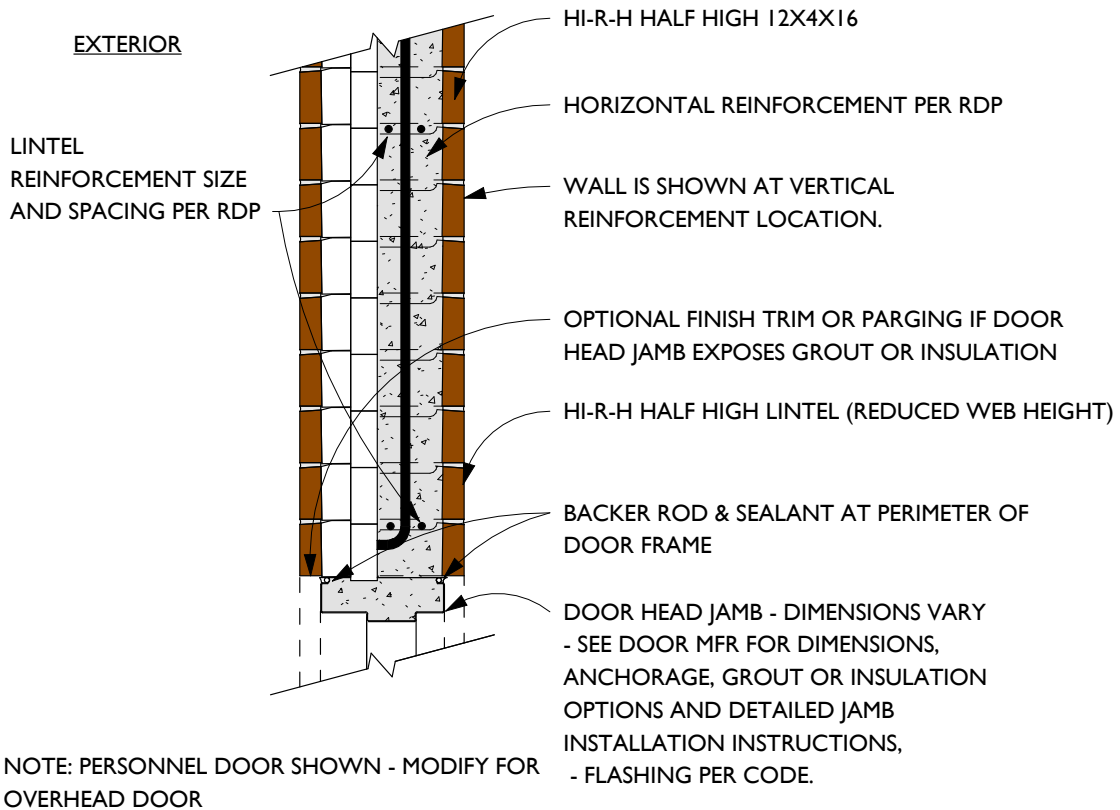

\*RDP = REGISTERED DESIGN PROFESSIONAL

\*INTEGRAL WATER REPELLENT FOR CMU AND MORTAR REQUIRED

\*SPRAY APPLIED WATER REPELLENT RECOMMENDED OVER TOP OF FINISHED ASSEMBLY

\*THIS DETAIL IS A STANDARD DETAIL. DESIGNERS SHOULD MAKE SITE SPECIFIC INVESTIGATIONS TO DETERMINE ACTUAL DESIGN REQUIREMENTS.

## Door Openings-Lintel

### Detail 4-5211 - HI-R-H Half High - Door Head and Lintel Using HI-R/HI-R-H Closed Bottom Lintel Unit

PLEASE CONFIRM  
LOCAL AVAILABILITY  
OF HI-R/HI-R-H CLOSED BOTTOM LINTEL  
PRIOR  
TO SPECIFYING

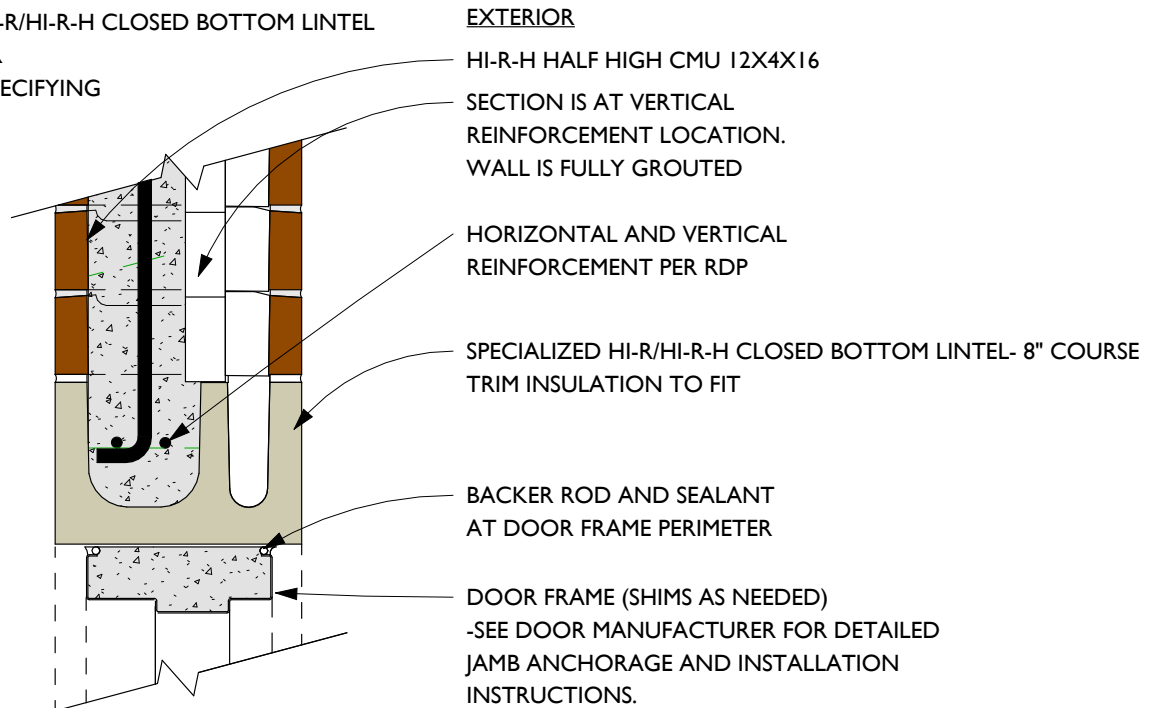

\*RDP = REGISTERED DESIGN PROFESSIONAL

\*INTEGRAL WATER REPELLENT FOR CMU AND MORTAR REQUIRED

\*SPRAY APPLIED WATER REPELLENT RECOMMENDED OVER TOP OF FINISHED ASSEMBLY

\*THIS DETAIL IS A STANDARD DETAIL. DESIGNERS SHOULD MAKE SITE SPECIFIC INVESTIGATIONS TO DETERMINE ACTUAL DESIGN REQUIREMENTS.

## Door Opening - Jamb

### Detail 4-5212 - HI-R-H Half High - Door Jamb - HI-R-H Half High Jamb Unit

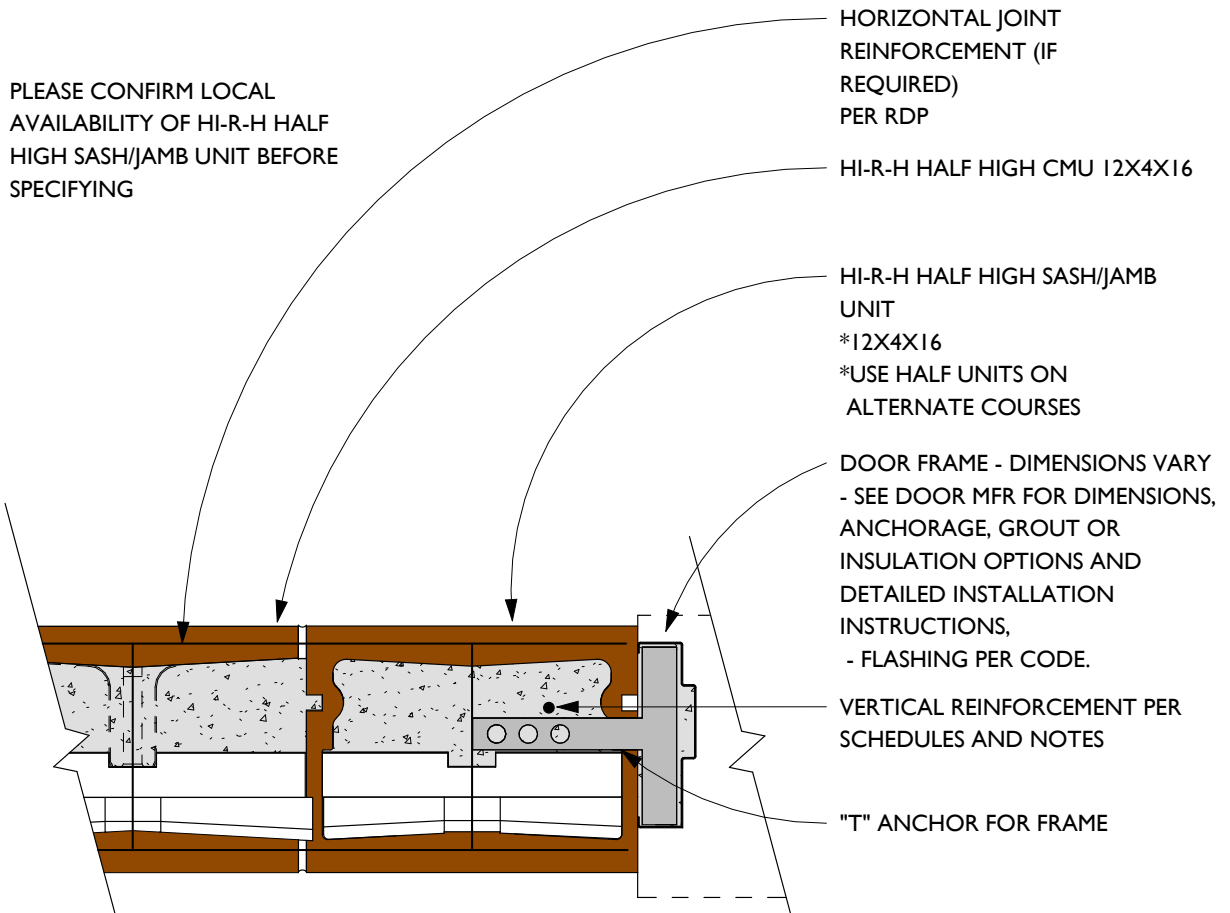

NOTE: PERSONNEL DOOR SHOWN -  
MODIFY FOR OVERHEAD DOOR  
SELECTED

NOTE: HALF JAMB UNITS MAY BE  
FLIPPED TO ALLOW USE OF LEFT  
OR RIGHT HALF UNITS  
INTERCHANGEABLY. FLIP SO  
THAT LOCATION OF SASH LINES  
UP WHEN PLACED. TAKE CARE  
TO MAINTAIN COURSE HEIGHT  
WHEN USING FLIPPED UNITS

\*THIS DETAIL IS A STANDARD DETAIL. DESIGNERS SHOULD MAKE SITE SPECIFIC INVESTIGATIONS TO DETERMINE ACTUAL DESIGN REQUIREMENTS.

Detail 4-5213 - HI-R-H Half High - Door Jamb - CMU Jamb

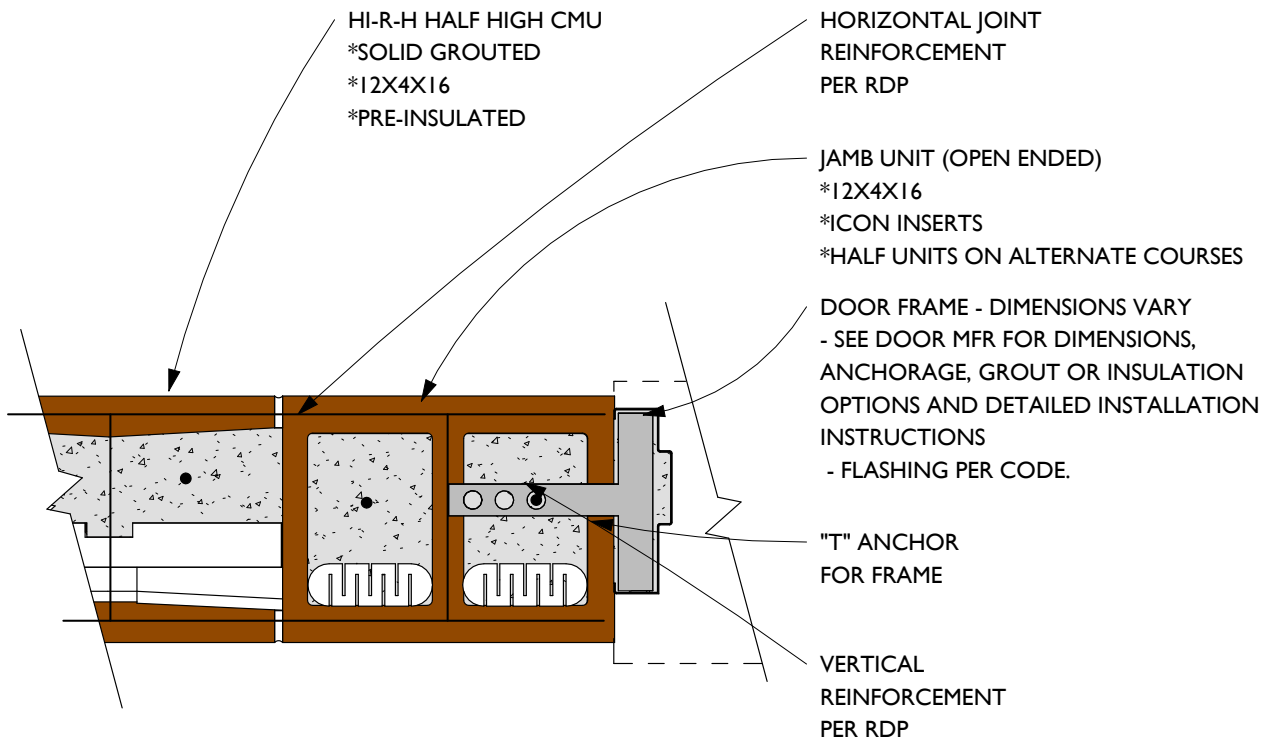

NOTE: PERSONNEL DOOR SHOWN -  
MODIFY FOR OVERHEAD DOOR  
SELECTED

\*RDP = REGISTERED DESIGN PROFESSIONAL

\*INTEGRAL WATER REPELLENT FOR CMU  
AND MORTAR REQUIRED

\*SPRAY APPLIED WATER REPELLENT  
RECOMMENDED OVER TOP OF FINISHED  
ASSEMBLY

\*THIS DETAIL IS A STANDARD DETAIL. DESIGNERS SHOULD MAKE SITE SPECIFIC INVESTIGATIONS TO DETERMINE ACTUAL DESIGN REQUIREMENTS.

### **Additional Notes – Door openings:**

1. See notes to Window openings.
2. All details are available in Revit® and AutoCAD® – the numbering of the details in this manual corresponds to that used in the Revit® and AutoCAD® files.

**Detail 4-5300- HI-R-H Half High - Precast Plank Non-Bearing Wall**

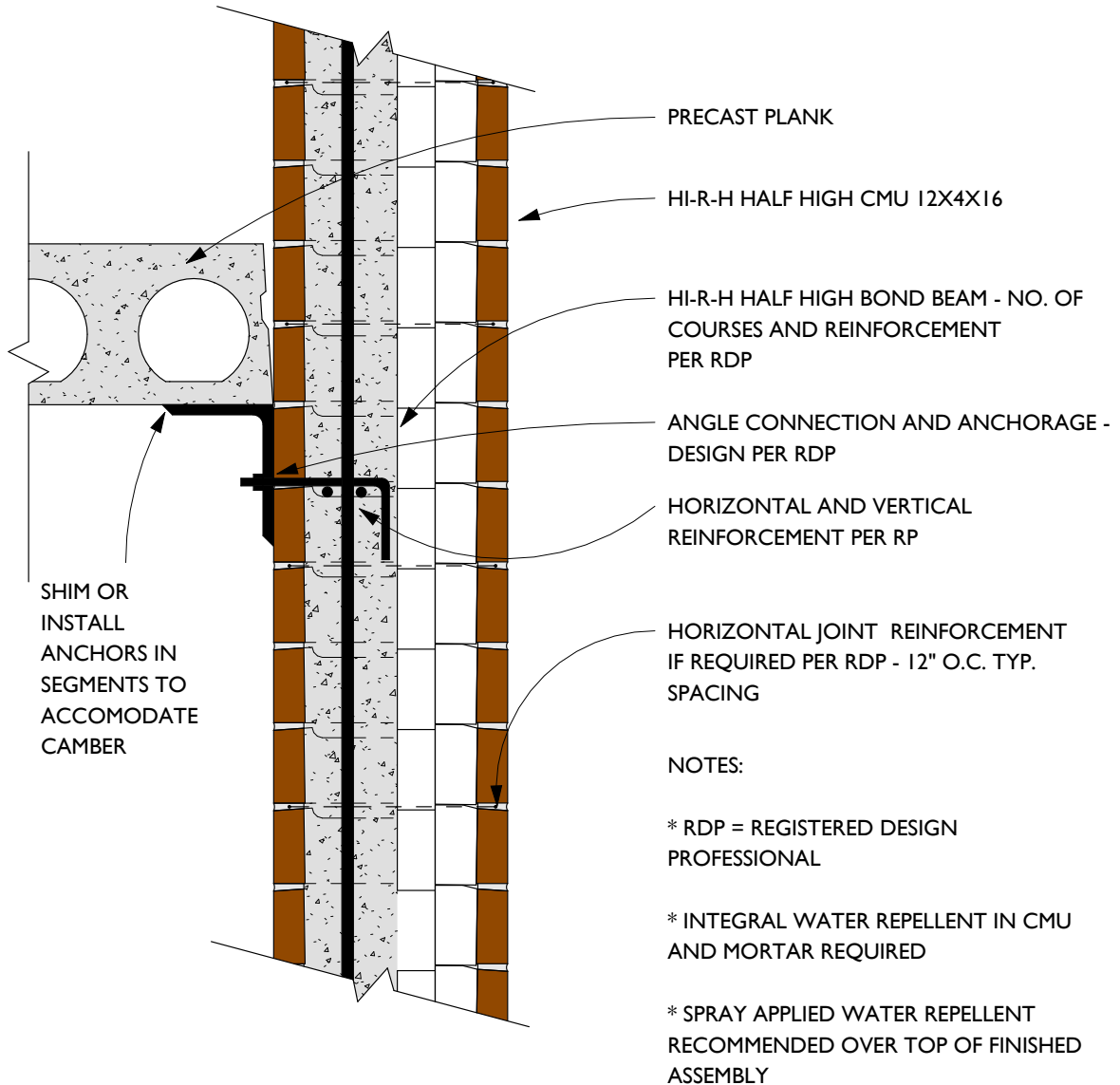

\*THIS DETAIL IS A STANDARD DETAIL. DESIGNERS SHOULD MAKE SITE SPECIFIC INVESTIGATIONS TO DETERMINE ACTUAL DESIGN REQUIREMENTS.

Detail 4-5301- HI-R-H Half High - Precast Plank Bearing Wall

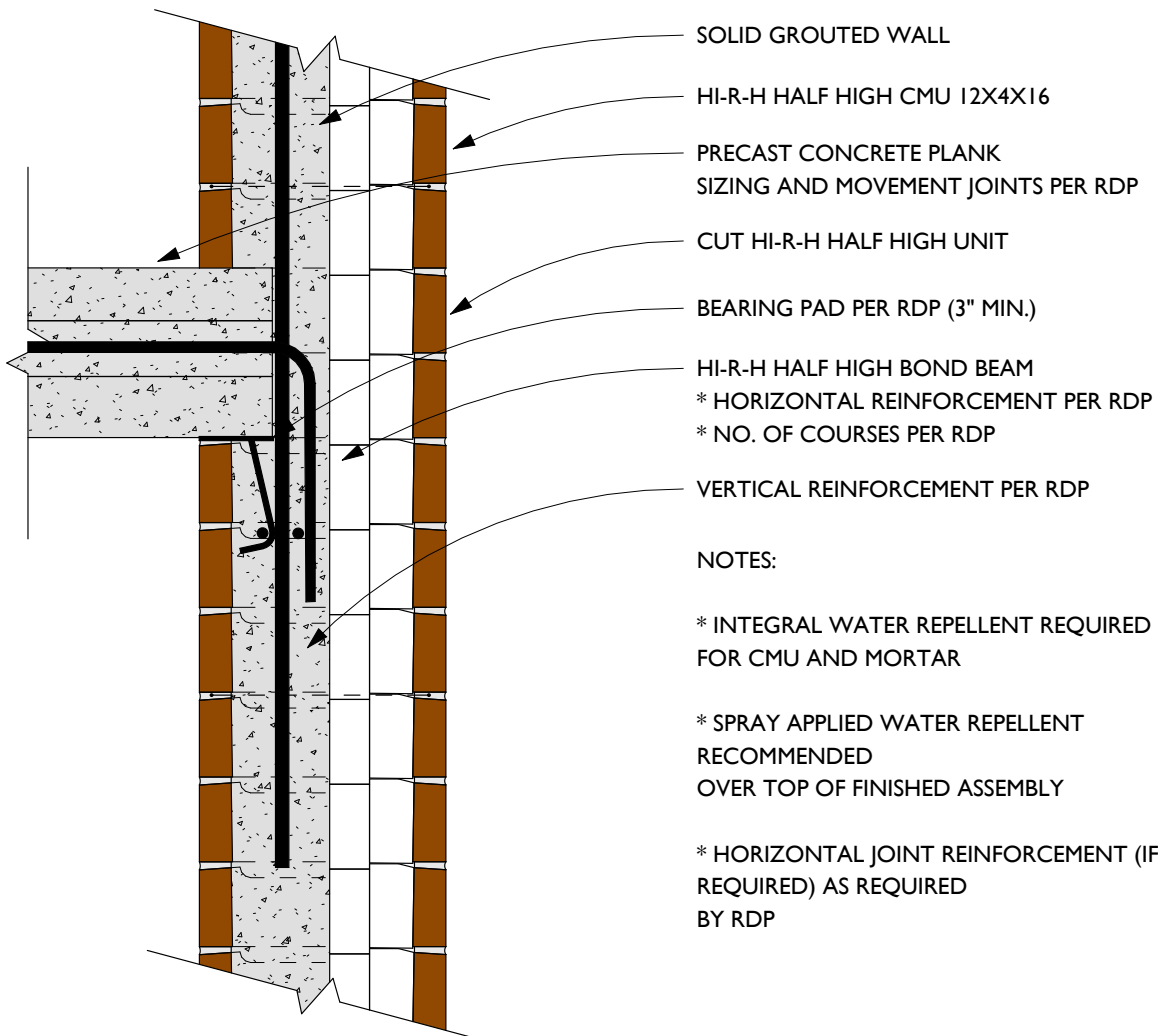

\*THIS DETAIL IS A STANDARD DETAIL. DESIGNERS SHOULD MAKE SITE SPECIFIC INVESTIGATIONS TO DETERMINE ACTUAL DESIGN REQUIREMENTS.

**Additional Notes – Planks:**

1. See notes to regarding bond beams.
2. All details are available in Revit® and AutoCAD® – the numbering of the details in this manual corresponds to that used in the Revit® and AutoCAD® files.

Detail 4-5310 - HI-R-H Half High - Parapet Bearing Wall

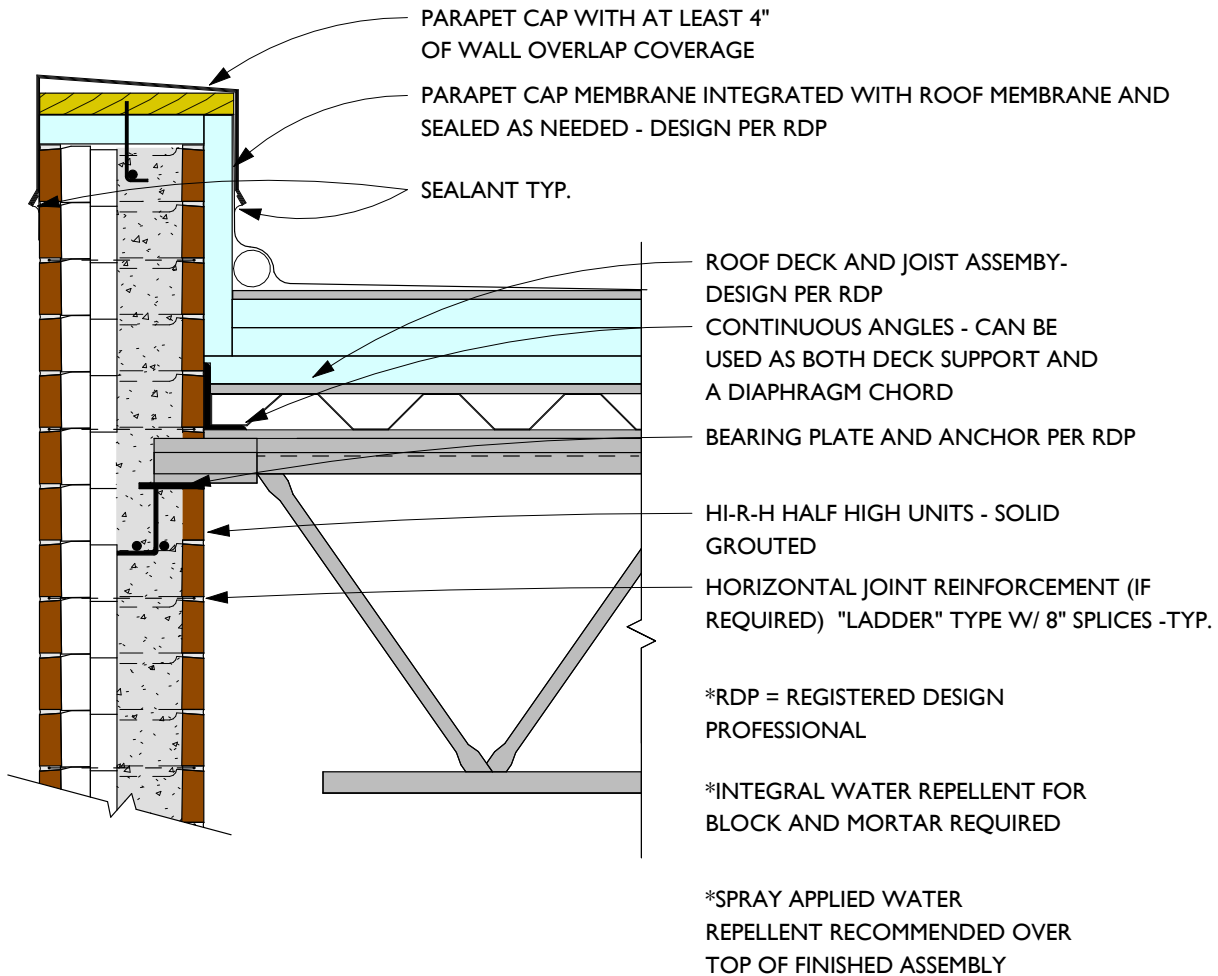

\*THIS DETAIL IS A STANDARD DETAIL. DESIGNERS SHOULD MAKE SITE SPECIFIC INVESTIGATIONS TO DETERMINE ACTUAL DESIGN REQUIREMENTS.

Detail 4-5311 - HI-R-H Half High - Parapet Non-Bearing Wall

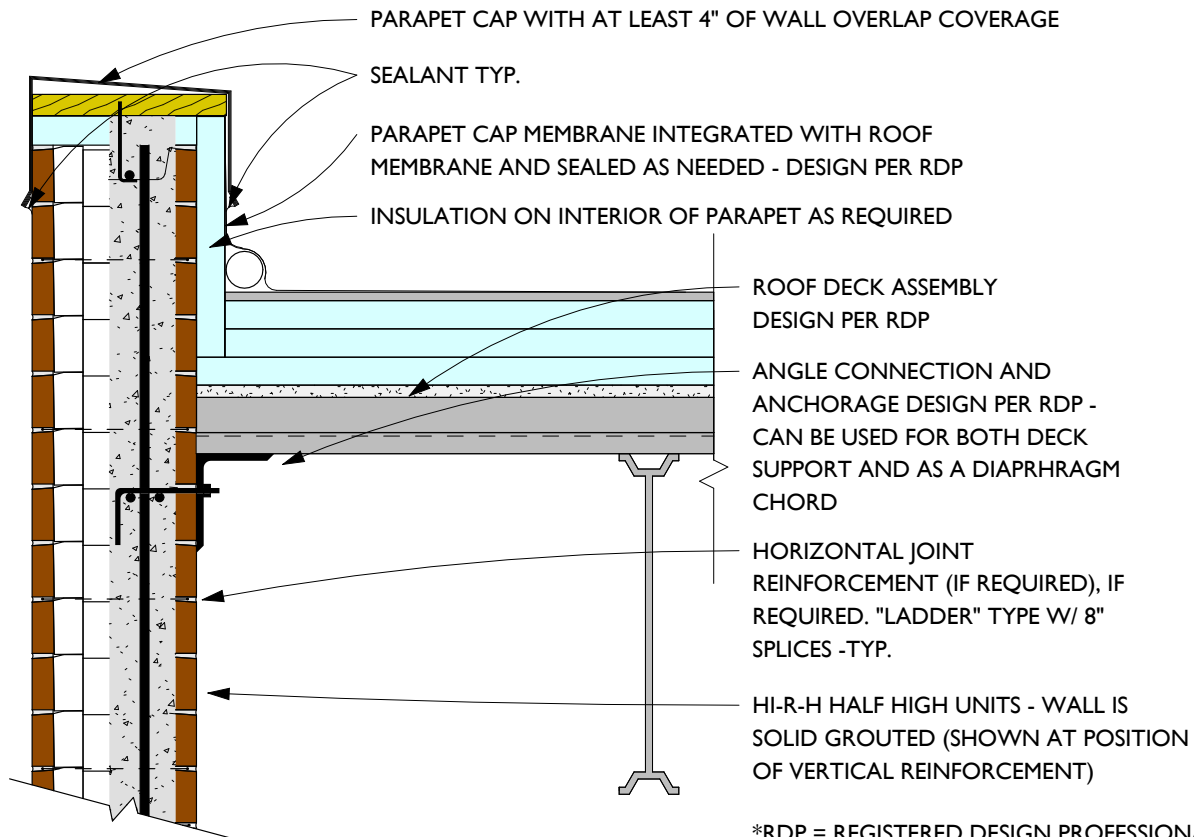

\*RDP = REGISTERED DESIGN PROFESSIONAL

\*INTEGRAL WATER REPELLENT FOR BLOCK AND MORTAR REQUIRED

\*SPRAY APPLIED WATER REPELLENT RECOMMENDED OVER TOP OF FINISHED ASSEMBLY

\*THIS DETAIL IS A STANDARD DETAIL. DESIGNERS SHOULD MAKE SITE SPECIFIC INVESTIGATIONS TO DETERMINE ACTUAL DESIGN REQUIREMENTS.

**Additional Notes – Roof Joist and Parapet:**

1. See notes regarding bond beams.
2. Insulating the inward face of the parapet provides protection against thermal bridging at that location.
3. All details are available in Revit® and AutoCAD® – the numbering of the details in this manual corresponds to that used in the Revit® and AutoCAD® files.

Detail 4-5320 - HI-R-H Half High - Pilaster Section View

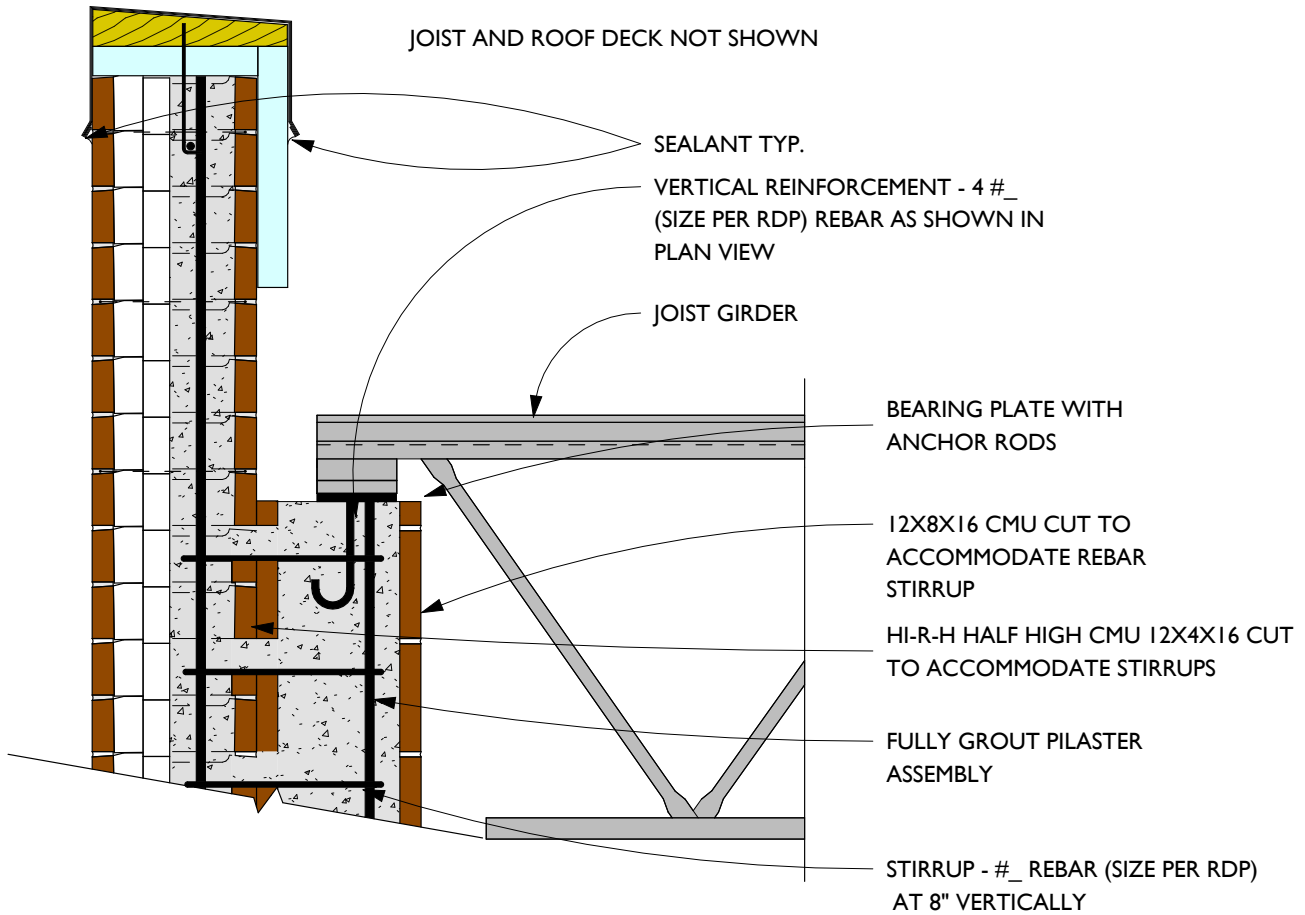

EXAMPLE ONLY; NOT FOR CONSTRUCTION -  
REINFORCEMENT REQUIREMENTS VARY

\*RDP = REGISTERED DESIGN PROFESSIONAL

\*INTEGRAL WATER REPELLENT FOR CMU  
AND MORTAR REQUIRED

\*SPRAY APPLIED WATER REPELLENT  
RECOMMENDED OVER TOP OF FINISHED  
ASSEMBLY

\*THIS DETAIL IS A STANDARD DETAIL. DESIGNERS SHOULD MAKE SITE SPECIFIC  
INVESTIGATIONS TO DETERMINE ACTUAL DESIGN REQUIREMENTS.

Detail 4-5321 - HI-R-H Half High - Pilaster Plan View

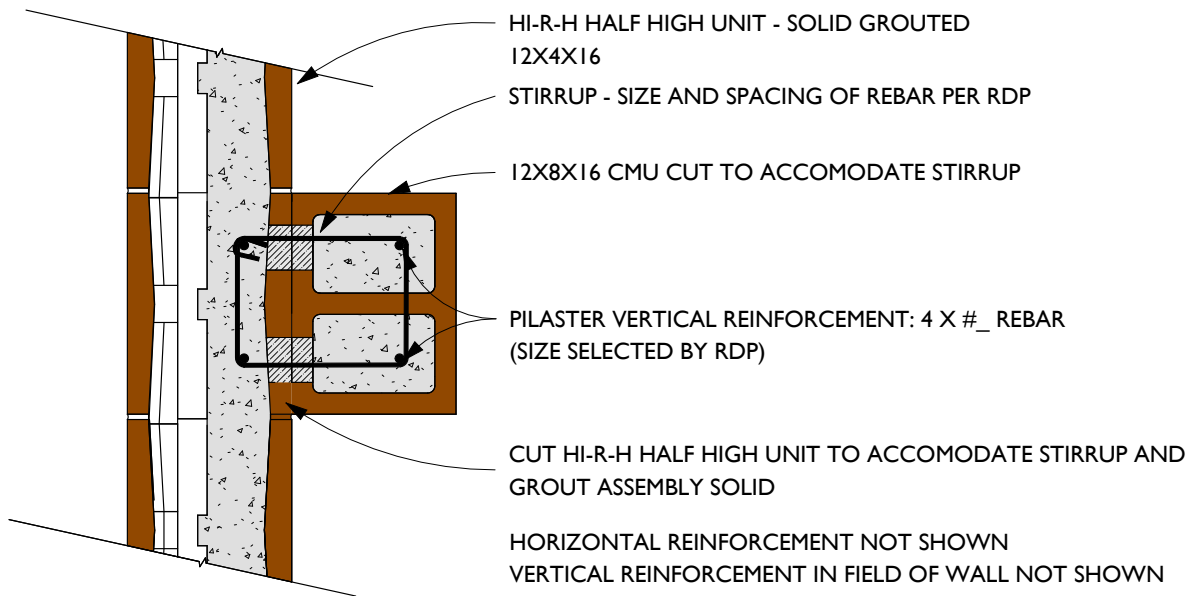

\*RDP = REGISTERED DESIGN PROFESSIONAL

\*INTEGRAL WATER REPELLENT FOR BLOCK  
AND MORTAR REQUIRED

\*SPRAY APPLIED WATER REPELLENT  
RECOMMENDED OVER TOP OF FINISHED  
ASSEMBLY

\*THIS DETAIL IS A STANDARD DETAIL. DESIGNERS SHOULD MAKE SITE SPECIFIC INVESTIGATIONS TO DETERMINE ACTUAL DESIGN REQUIREMENTS.

**Additional Notes – Pilaster:**

1. See notes regarding bond beams.
2. Pilasters are often a cost-effective addition to meet structural requirements for the building roof.
3. Insulating the inward face of the parapet provides protection against thermal bridging at that location.
4. All details are available in Revit® and AutoCAD® – the numbering of the details in this manual corresponds to that used in the Revit® and AutoCAD® files.



---

## GENERAL CMU DETAILS

---

Detail 4-0001 - CMU - Concrete Foundation - At Opening

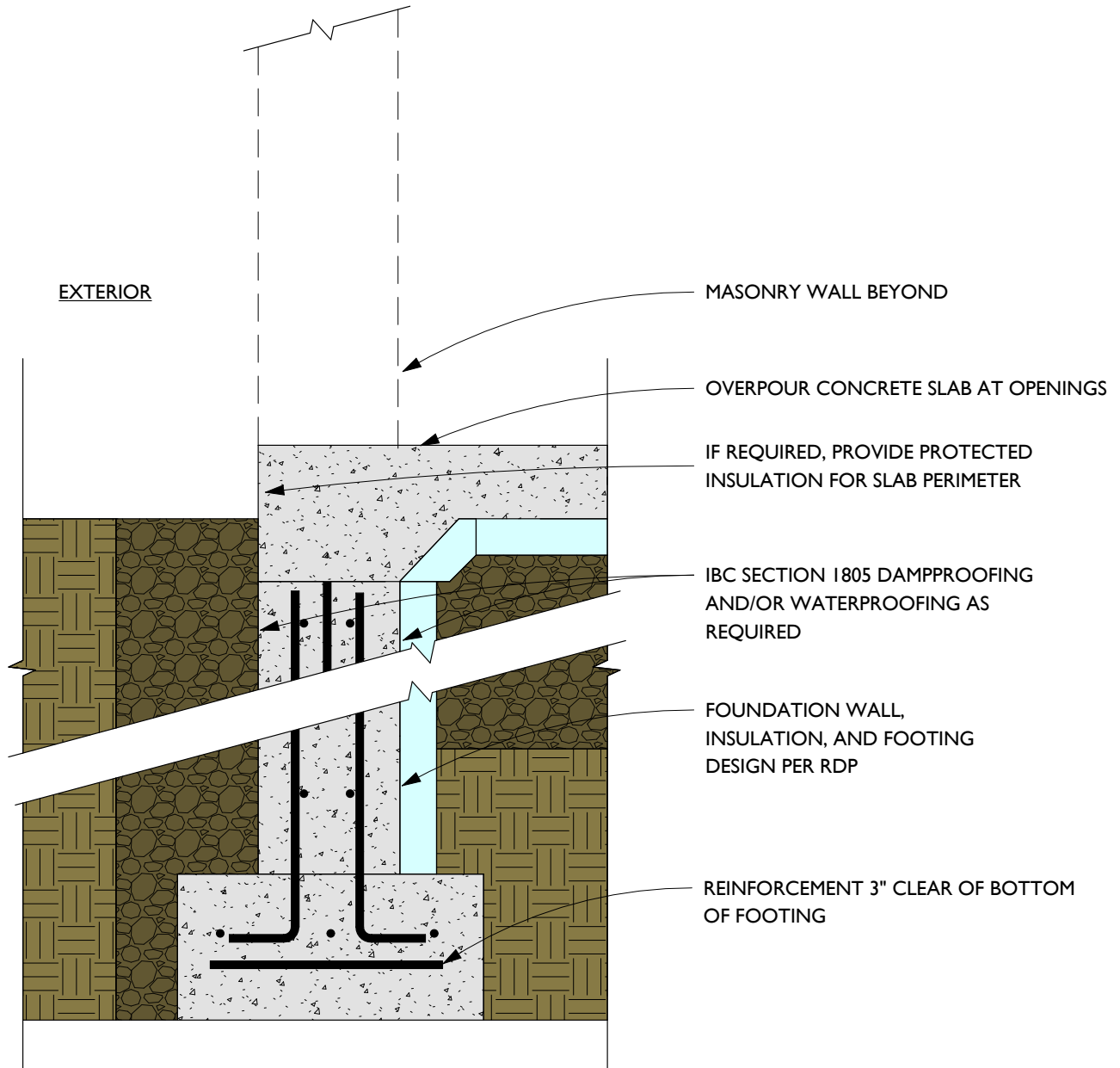

\*THIS DETAIL IS A STANDARD DETAIL. DESIGNERS SHOULD MAKE SITE SPECIFIC INVESTIGATIONS TO DETERMINE ACTUAL DESIGN REQUIREMENTS.

Detail 4-0002 - CMU - Concrete Foundation - Loading Dock

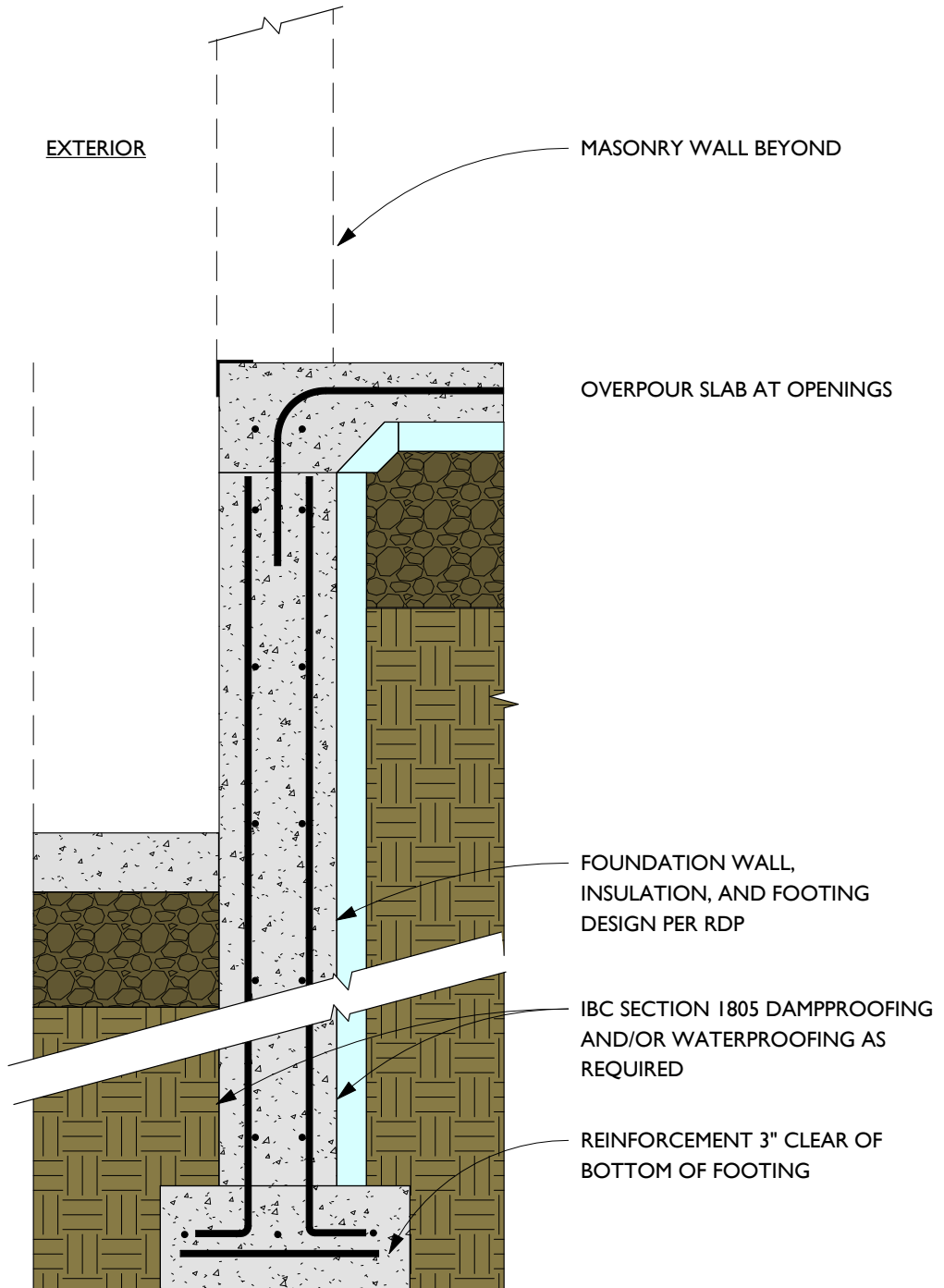

\*THIS DETAIL IS A STANDARD DETAIL. DESIGNERS SHOULD MAKE SITE SPECIFIC INVESTIGATIONS TO DETERMINE ACTUAL DESIGN REQUIREMENTS.

Detail 4-0004 - CMU - CMU Foundation - At Opening

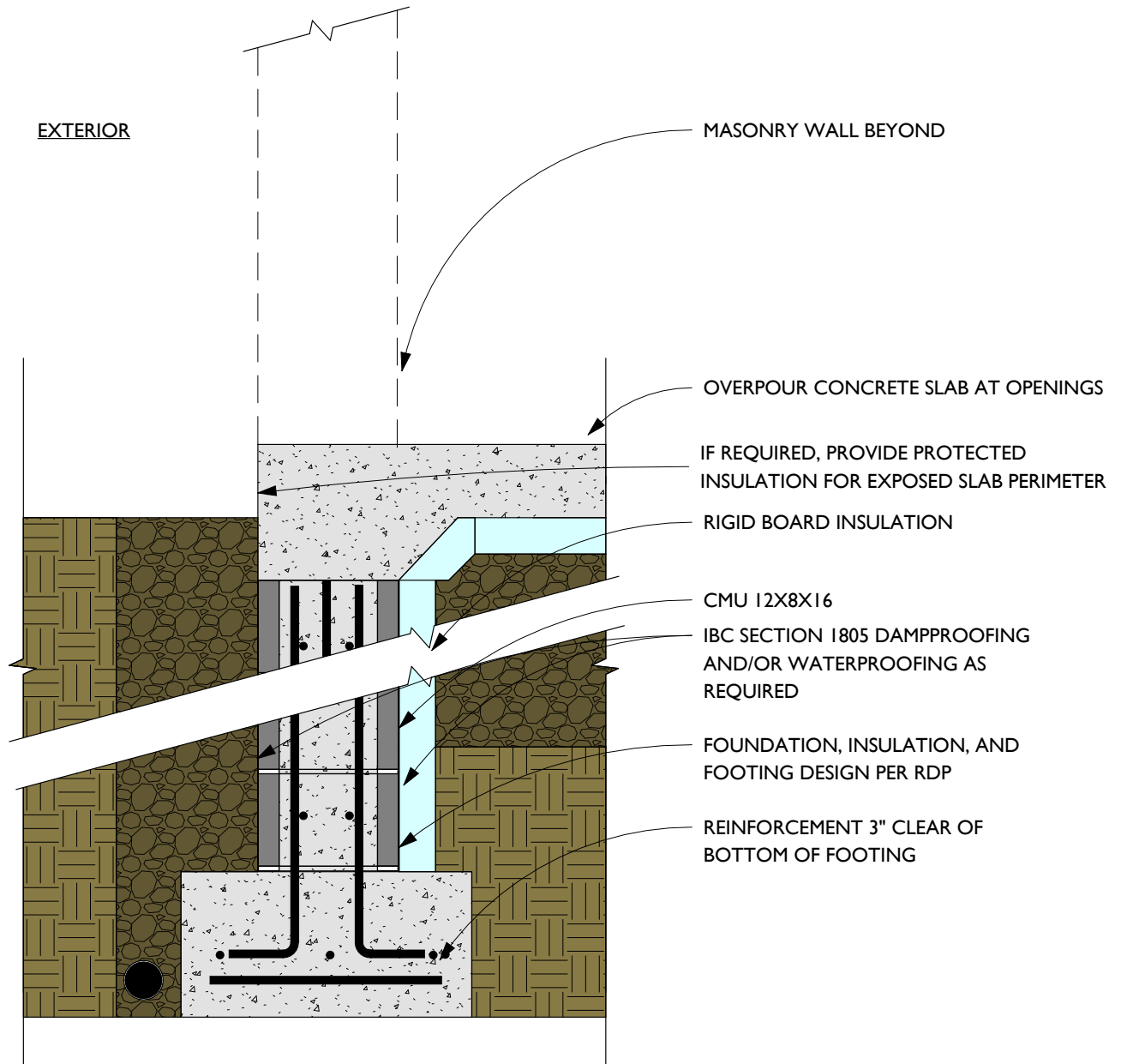

\*THIS DETAIL IS A STANDARD DETAIL. DESIGNERS SHOULD MAKE SITE SPECIFIC INVESTIGATIONS TO DETERMINE ACTUAL DESIGN REQUIREMENTS.



# Service and Support

The Concrete Products Group LLC (CPG) consists of regional market leaders in the concrete products industry. CPG provides industry leading support and service throughout the nation. CPG is organized to provide consistent, top-quality products to regional and national customers.

Please contact us if we can assist with your next project.

[www.concreteproductsgroup.com](http://www.concreteproductsgroup.com)

800-789-0872

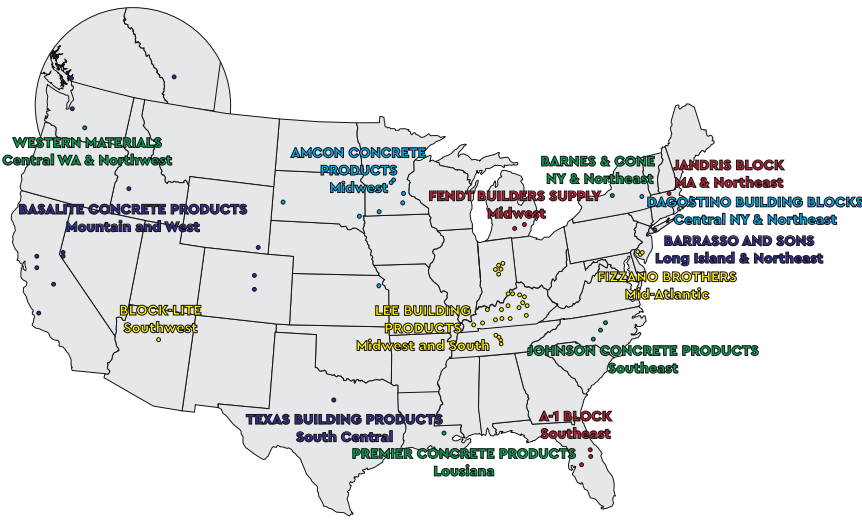

**A-1 BLOCK**  
1617 South  
Division Avenue  
Orlando, FL 32805

**AMCON CONCRETE  
PRODUCTS, LLC**  
2025 Centre Pointe  
Blvd., Suite 300  
Mendota Heights, MN  
55120-1221

**BARNES & CONE**  
P.O. Box 280  
5894 Court St. Rd.  
Syracuse, NY  
13206-0280

**BASALITE CONCRETE  
PRODUCTS LLC**  
605 Industrial Way  
Dixon, CA  
95620

**BARRASSO AND SONS  
INC**  
160 Floral Park Street  
Islip Terrace, NY  
11752

**BLOCK-LITE COMPANY**  
900 E Industrial Dr,  
Flagstaff, AZ 86004

**DAGOSTINO BUILDING  
BLOCKS, INC.**  
1111 Altamont Avenue  
Schenectady, NY 12303

**FENDT BUILDERS  
SUPPLY**  
22005 Gill Rd,  
Farmington, MI  
48335

**FIZZANO BROTHERS  
CONCRETE  
PRODUCTS, INC.**  
1776 Chester Pike  
Crum Lynne, PA  
19022-1299

**JANDRIS BLOCK**  
202 High St.  
Gardner, MA  
01440

**JOHNSON CONCRETE  
COMPANY**  
217 Klumac Road  
Salisbury, NC 28144

**PREMIER COICRETE  
PRODUCTS**  
38200 LA Highway 16  
Denham Springs, LA  
70706

**LEE BUILDING  
PRODUCTS**  
4301 Industrial Drive  
Bowling Green, KY  
42101

**TEXAS BUILDING  
PRODUCTS**  
3261 Highway 108  
Strawn, Texas 76454

**WESTERN MATERIALS  
COMPANY**  
1202 South First Street  
Yakima, WA 98901



**CONCRETE  
PRODUCTS GROUP**