

Modular Access Systems

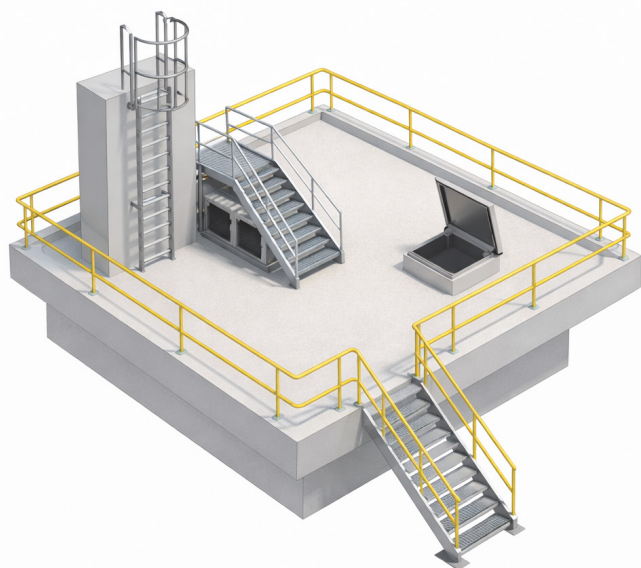

Material

- Manufactured from high grade structural aluminium
- Modular Access fixing brackets, joining plates and support feet manufactured from profiled stainless steel plate powder coated
burnt orange
- Modular Access T-Bolt manufactured from stainless steel

Dimensions

- Modular Access 80 extrusion: 80 x 38mm
- Modular Access 180 extrusion: 180 x 32mm
- Platform support extrusion: 58 x 38mm
- Stair tread: 250 x 40mm
- Handrail post extrusion: 58 x 38mm
- Aluminium expanded mesh: 600 x 13mm
- Fixings
- Modular Access T-Bolt: M10 x 25
- Tek screw: 12g stainless steel
- Weight
- Modular Access 80 extrusion: 2.6kg/m
- Modular Access 180 extrusion: 4.0kg/m
- Modular Access platform deck
(aluminium mesh only - 600mm wide): 4.2kg/m²
- Modular Access stair tread: 3.9kg/m

Working Load Limit

- Modular Access platforms are designed to BS EN ISO 14122:2016
(Platform working load limit 2.5kPa)
- Modular Access stairs are designed to BS EN ISO 14122:2016
(Stair working load limit 2.5kPa)

Characteristics

- Modular Design
- High Strength Aluminium construction
- Unique, self-locking Modular Access T-Bolt assembly
- Lightweight components
- Strong & Durable

Quality Assurance

All Modular Access components are manufactured by our ISO-9001 certified partners. Steelway Safety recognises the importance of all products being consistent in quality and regularly inspects the production process to ensure best quality products are produced.

Compliance

Steelway Modular Access Systems are designed and tested to comply with requirements of BS EN ISO 14122:2016 and relevant statutory HSE guidelines.

Product Warranty

25 years from date of purchase subject to correct installation, use and maintenance, in accordance with manufacturer's specifications and recommendations.

Inspection & Maintenance

Inspection and certification required every 12 months by competent person, in accordance with manufacturer's specification and relevant HSE statutory guidelines.

Important Notes

Failure to supply and/or install proprietary product in accordance with above standards and codes, specifications and instructions voids complete system certification and/or warranty.

Modular Access Systems

Step Units

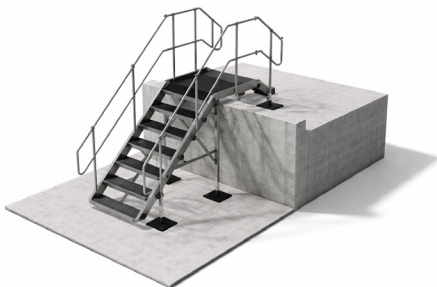
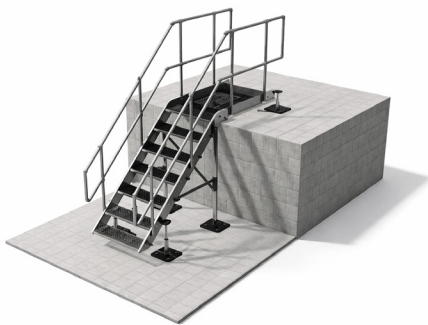
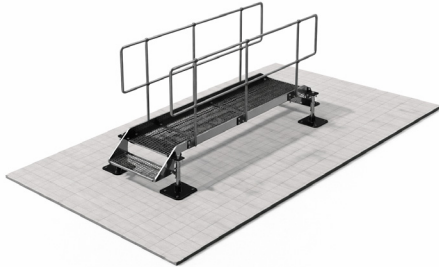

Step Units provide a straightforward solution to complex access challenges. They allow safe access over ducting, pipework, cable trays, gutters, and parapet walls

Our step range has been developed to deliver a standardised, off-the-shelf solution in galvanised mild steel. These flat-pack step units are engineered to meet the practical challenges of creating safe rooftop and industrial access - combining convenience with performance.

Extensive research and development, along with investment in advanced design and manufacturing technology, has enabled us to create a fully compliant system designed and manufactured to the highest industry standards.

- Designed in accordance with BS 4592-0:2006 + A1:2012 – Flooring, stair treads and handrails for industrial use
- Manufactured to BS EN ISO 3834-2:2005
- Manufactured to BS EN 1090-1:2009 + A1:2011 & 2:2008
- Fully CE Marked

The result is a precision-manufactured product that is simple to specify, easy to install, and built to last.

Key Features

- On-site adjustability with the safety and finish of a bespoke solution
- Available in Up & Onto or Up & Over configurations
- Compatible with a range of platforms to safely clear obstructions
- Supplied with freestanding feet without roof penetration
- Fully approved through required structural and safety calculations
- Step Units deliver the flexibility you need with full compliance

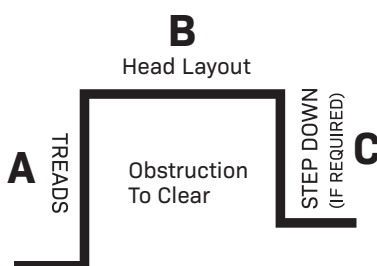

Height A (mm)	Treads	Height C (mm)
287 - 407	1	292 - 407
432 - 627	2	432 - 627
652 - 847	3	652 - 847
872 - 1067	4	872 - 1067
1092 - 1287	5	1092 - 1287
1312 - 1727	6	1212 - 1512
1533 - 1727	7	1533 - 1727

Up & Over Platform B (mm)	Part	Up & Onto Platform B (mm)
Up to 538	1	Up to 502
Up to 1038	2	Up to 1002
Up to 1538	3	Up to 1502
Up to 2038	4	Up to 2002
Up to 2538	5	

Step Units are manufactured in galvanised mild steel with freestanding feet. Step units are based on 800mm wide treads and include handrail to both sides. All products have been approved through the necessary safety & structural calculations. brackets to suit masonry, steel or metal profile cladding.

Modular Access Systems / Staircases & Platforms

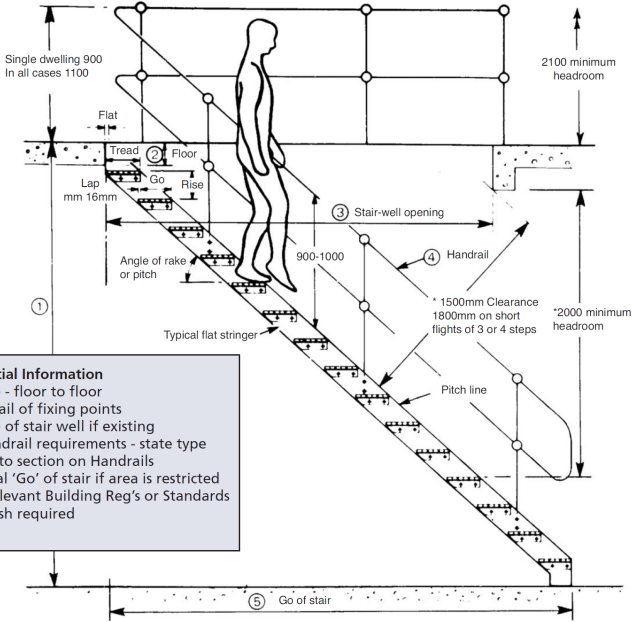

Essential Information

1. Rise - floor to floor
2. Detail of fixing points
3. Size of stair well if existing
4. Handrail requirements - state type Refer to section on Handrails
5. Total 'Go' of stair if area is restricted
- *6. Relevant Building Reg's or Standards
7. Finish required

Ship type /companion ladders, offer an alternative option in a situation where a vertical ladder is unsuitable and there is insufficient space for a staircase.

The 65 degree to 75 degree slope is easier to negotiate than a vertical or near vertical ladder. We recommend that the maximum vertical rise should not exceed 3000mm and the width between stringers should preferably be between limits of 450mm and 550mm. It should be noted that 250mm minimum foot space should be allowed from the nose of treads to the wall, platform face or other obstruction, see illustration. A top tread should be provided at floor level, or the platform can be arranged to run over, but the minimum foot space should still be maintained. Handrails are necessary on this type of ladder and should be provided on both sides without exception.

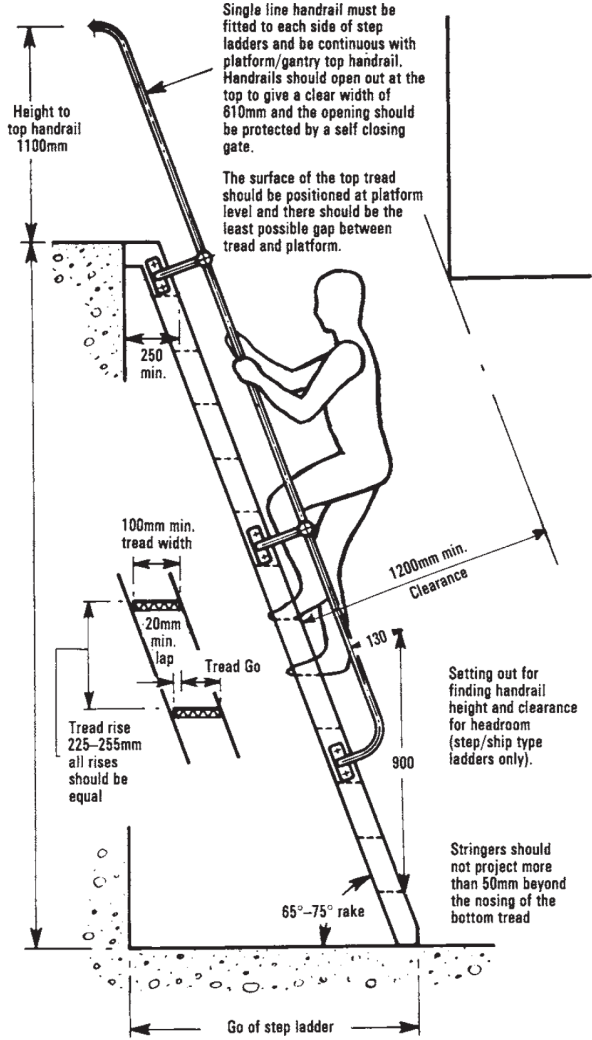

Staircase Recommendations Chart

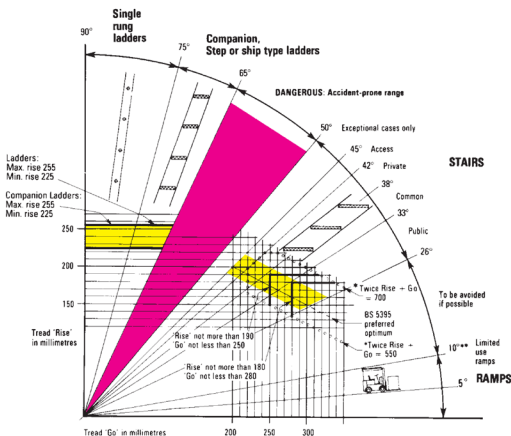

This chart gives preferred rise/go dimensions see section coloured yellow for any given rake of staircase or ladder and is based on our recommended formula:

Twice the rise plus the go = not less than 570mm nor more than 640mm (550 to 700).

'Go' is the term used for the horizontal dimension of a stair or tread. 'Rise' is the vertical dimension.

'Overlap' is the amount the nosing of one tread overlaps the one below (minimum 16mm).

Example: A single flight stair has a rise of 2600mm and has to comply with a minimum tread 'go' of 250mm and a maximum rise of 190mm. From the chart below we see with a 'go' of 250mm an acceptable rise will be about 185mm. This will give 14 equal rises. The stair will thus have an angle of rake pitch of 36° 36' and will fall within the limits required for this type of stair. Also the aggregate of twice the rise plus the go equals 620mm, close to the optimum

Modular Access Systems

Industrial Flooring - Open Type Flooring - Diamond Pattern

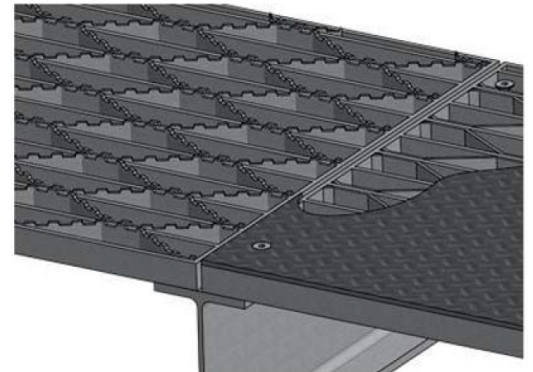
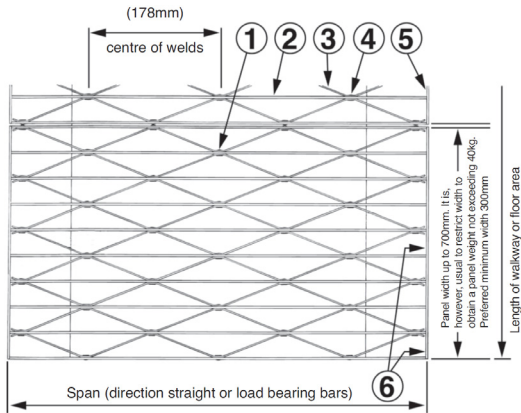

KEY

1. "Steelway" mild steel diamond pattern open mesh flooring of all welded construction.
2. Straight bar (load bearing bars).
3. Pressed bar, acts as spacer and transmits localised loads to adjacent load-bearing bars.
4. Strong stitch welded joints.
5. Nosing bar (binding bar) 5mm thick flat bar welded along the span edge of all panels. Nosing bars are not intended to be load bearing.
6. Every fourth or fifth straight bar and the edge bars are strongly

Correct (Right)

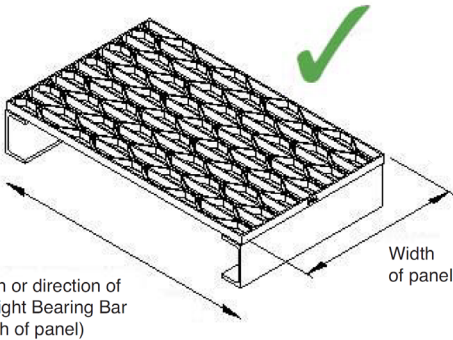

Incorrect (Wrong)
Ends of Load Bearing Bars are not supported

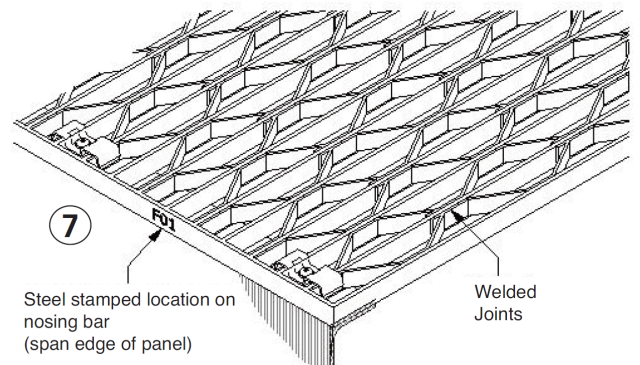
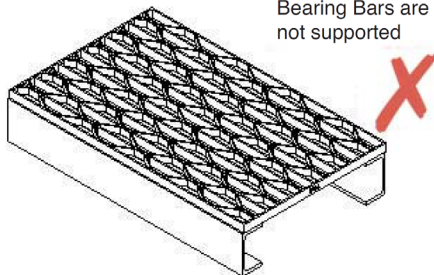

Modular Access Systems

Industrial Flooring - Open Type Flooring - Diamond Pattern



Load Bearing bars (mm)	Type	Mass kg/m ²		Clear span (mm)												Max'm span (mm) for 5 kN/m ²	Max'm span (mm) for 1.5 kN	
				600	750	900	1050	1200	1350	1500	1650	1800	1950	2100	2250			2400
FL25	20x3	32.26	U.D.L	39.28	20.16	10.37	5.60	3.26									1080	
			C.L	7.99	5.02	3.07	1.92	1.26	0.90									
FL25H	20x3	41.99	U.D.L	63.19	32.36	16.64	8.98	5.27	3.29								1133	
			C.L	10.68	6.71	4.10	2.57	1.71	1.20	0.87								1133
FL30L	25x3	39.47	U.D.L	68.04	34.84	17.92	9.67	5.67	3.54								1133	
			C.L	13.83	8.76	5.35	3.35	2.23	1.57	1.14	0.85							1133
FL30H	20x3	51.12	U.D.L	109.20	55.91	28.76	15.52	9.10	5.68	3.73	2.55						1133	
			C.L	19.20	12.16	7.43	4.65	3.10	2.17	1.58	1.19	0.91						1133
FL35L	20x3	42.88	U.D.L	100.75	55.32	28.46	15.36	9.00	5.62	3.69	2.52						1133	
			C.L	15.99	11.81	7.22	4.52	3.01	2.11	1.54	1.15	0.89						1133
FL35H	20x3	56.58	U.D.L	161.79	88.78	45.67	24.65	14.45	9.02	5.92	4.04	2.85					1133	
			C.L	22.26	16.45	10.05	6.29	4.20	2.94	2.14	1.60	1.23	0.97	0.78				1133
FL40L	20x3	46.28	U.D.L	131.66	82.58	42.48	22.93	13.44	8.39	5.51	3.76	2.65					1133	
			C.L	18.05	13.86	9.31	5.83	3.89	2.72	1.98	1.49	1.14	0.90					1133
FL40H	20x3	62.04	U.D.L	211.40	132.53	68.17	36.80	21.57	13.47	8.84	6.03	4.26	3.09				1133	
			C.L	26.25	20.17	13.54	8.47	5.65	3.96	2.88	2.16	1.66	1.31	1.05	0.85			1133
FL45L	20x3	49.68	U.D.L	166.70	106.56	60.48	32.65	19.14	11.95	7.84	5.35	3.76	2.74				1133	
			C.L	20.68	15.88	12.00	7.51	5.01	3.51	2.55	1.92	1.47	1.16	0.93	0.75			1133
FL45H	20x3	67.50	U.D.L	267.63	171.11	97.07	52.39	30.71	19.17	12.58	8.59	6.07	4.40	3.27			1133	
			C.L	6.61	20.44	15.45	9.67	6.45	4.52	3.29	2.47	1.90	1.49	1.19	0.97	0.80		
FL50L	20x3	53.08	U.D.L	205.86	131.61	82.96	44.78	26.25	16.39	10.75	7.34	5.19	3.76	2.60			1133	
			C.L	20.41	15.68	12.72	8.24	5.50	3.85	2.80	2.10	1.62	1.27	1.02	0.83			1133
FL50H	20x3	72.96	U.D.L	330.49	211.32	133.15	71.87	42.13	26.30	17.26	11.79	8.32	6.04	4.49	3.41	2.63	1133	
			C.L	31.39	24.12	19.56	12.67	8.45	5.92	4.31	3.23	2.49	1.95	1.56	1.27	1.05		
FL65H	40x3	100.36	U.D.L	558.69	357.30	247.90	157.90	92.56	57.78	37.91	25.89	18.28	13.27	9.87	5.78	5.78	1133	
			C.L	68.68	52.79	42.85	36.00	24.02	16.82	12.24	9.18	7.07	5.55	4.44	2.97	2.97		
FL70	40x3	105.82	U.D.L	648.03	414.46	287.58	197.21	115.60	72.17	47.35	32.34	22.84	16.58	12.33	7.23	7.23	1133	
			C.L	65.38	50.25	40.78	34.30	24.63	17.25	12.55	9.42	7.24	5.69	4.56	3.05	3.05		

When using the load tables please consider the following notes:

1. Material grade S275JR, $f_y = 275\text{N/mm}^2$ in accordance with BS EN 1993-1-1 (EC3).
2. Flooring panels simply supported.
3. The loads shown in the table are based upon the design strength divided by a partial safety factor, $Q = 1.5$, allowance for the self weight of the flooring has been included.
4. Deflections limited to $L/200$, 10mm or 4mm* whichever is the lesser. * The difference in level between loaded and unloaded neighbouring panels has been limited to 4mm in accordance with BS EN ISO 14122-2:2001+A1:2010 & BS 4592-0:2006+A1:2012. Should the neighbouring panels be secured together the 4mm deflection rule need not apply and larger spans may be achievable, contact our sales team for further information.
5. Serrated load bearing bars to provide enhanced slip resistance are available upon request, contact our sales team for further information.
6. Steelway Diamond pattern flooring complies with clause 4.2.4.4 of BS EN ISO 14122-2:2001 and 5.1 of BS 4592-0:2006+A1:2012, where the maximum opening shall not permit the passage of a 35mm diameter sphere. Should the working platform be above a place where people are continuously working, as opposed to passing occasionally or on fire escapes then the maximum opening should not permit the passage of a 20mm diameter sphere and an alternative floor type / means of protection to prevent falling objects should be provided. For further information and advice please contact our sales team.
7. Values in red are below the required UDL or CL load requirements for general duty loading of table ,1 BS 4592-0:2006+A1:2012.
8. U.D.L = Uniformly Distributed Load per square metre C.L = Concentrated load over 200mm x 200mm

Modular Access Systems

Industrial Flooring - Rectangular - Open Type Flooring

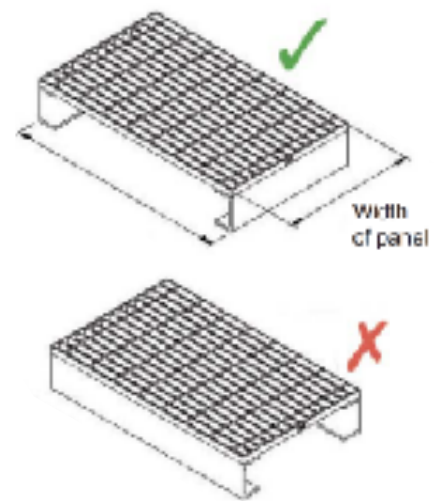
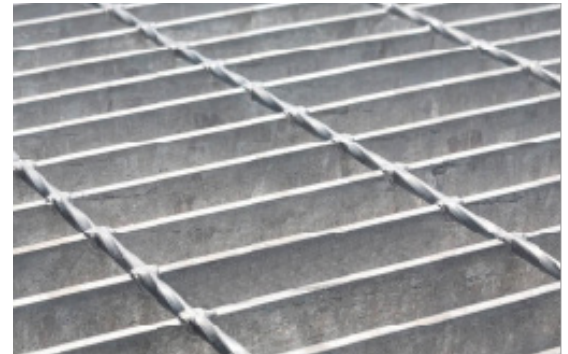
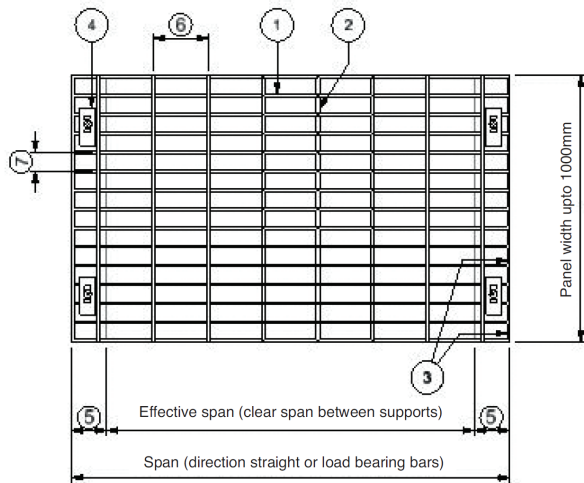

KEY

1. Load bearing bars (Straight bars).
2. Transverse twisted bars.
3. Nosing Bar (Binding bar) to be welded perpendicular to every fourth or fifth load bearing bar. Nosing bars are not intended to be load bearing. Bars shall be of equal thickness to the thickness of the load bearing bars and shall be flush with the top of the load bearing bars.
4. Fixing clip. Minimum four number clips per panel.
5. Load bearing bars must be supported at each end by a minimum of 25mm.
6. Transverse twisted bar centres Generally 50 or 100.
7. Load bearing bar centres. Generally 30, 34 or 41

Available in Mild Steel (self-colour or hot dip galvanised), & Stainless Steel

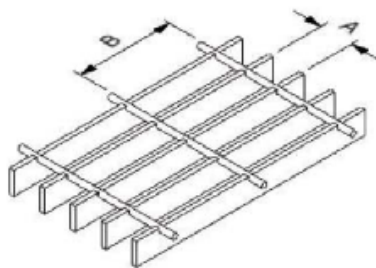

Stock Panels

These can be supplied in nominal 6m lengths by 1m wide.

Plain and Serrated Load Bearing Bars

Our standard range of gratings with the special transverse twisted bar provide better than average slip resistance. Where oily or icy conditions are likely to be prevalent, then gratings with serrated edge load bearing bars can be supplied for improved grip.

Fabrication

Your specific requirements are undertaken after submission of our detailed drawings for your approval. Our proposals will provide you with the optimum layout taking account of all requirements for cut-outs, shaping and supporting steelwork. For ease of installation on site, each fabricated panel is hard stamped on the binding bar with an erection mark to correspond with our layout drawings.

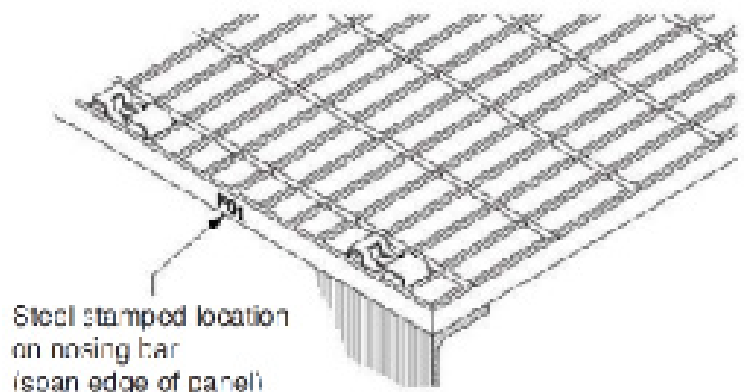

Pattern	Dim 'A'	Dim 'B'	Prevent passing of 35mm dia ball	Prevent passing of 20mm dia ball
41/100	41	100	No	No
41/50	41	50	No	No
34/100	34	100	Yes	No
34/50	34	50	Yes	No
30/100	30	100	Yes	No
30/50	30	50	Yes	No
23/100	23	100	Yes	Yes
41/24	41	24	Yes	Yes

Modular Access Systems

Industrial Flooring -Rectangular - Open Type Flooring



Rectangular Pattern Type 34/100

Load Bearing bars (mm)	Type	Mass kg/m ²	Load Type	Clear span (mm)												Max'm span (mm) for 5 kN/m ²	Max'm span (mm) for 1.5 kN	
				600	750	900	1050	1200	1350	1500	1650	1800	1950	2100	2250			2400
20 x 3	34/100	16.67	U.D.L	22.40	11.47	5.90	3.18										938	
			C.L	2.07	1.30	0.79												
25 x 3	34/100	20.20	U.D.L	43.75	22.40	11.52	6.22	3.65									1109	
			C.L	4.03	2.53	1.55	0.97											902
25 x 5	34/100	31.81	U.D.L	72.92	37.33	19.20	10.37	6.08	3.79								1260	
			C.L	6.72	4.22	2.58	1.62	1.08	0.75									1069
30 x 3	34/100	23.74	U.D.L	75.60	38.71	19.91	10.75	6.30	3.93	2.58							1271	
			C.L	6.91	4.38	2.68	1.67	1.12	0.78									1082
30 x 5	34/100	37.70	U.D.L	126.00	64.51	33.19	17.91	10.50	6.56	4.30	2.94						1445	
			C.L	11.52	7.30	4.46	2.79	1.86	1.30	0.95								1283
35 x 3	34/100	27.27	U.D.L	112.09	61.47	31.62	17.07	10.00	6.25	4.10	2.80						1427	
			C.L	9.41	6.95	4.25	2.66	1.77	1.24	0.90								1263
35 x 5	34/100	43.59	U.D.L	186.84	102.44	52.70	28.44	16.67	10.41	6.83	4.66	3.29					1622	
			C.L	15.68	11.59	7.08	4.43	2.96	2.07	1.51	1.13	0.87						1497
40 x 3	34/100	30.80	U.D.L	146.44	91.75	47.20	25.48	14.93	9.32	6.12	4.18	2.95					1578	
			C.L	12.29	9.44	6.34	3.97	2.65	1.86	1.35	1.01	0.78						1433
40 x 5	34/100	49.48	U.D.L	244.08	152.92	78.66	42.46	24.89	15.54	10.19	6.96	4.92	3.57	2.65			1792	
			C.L	20.49	15.74	10.57	6.62	4.41	3.09	2.25	1.69	1.30	1.02	0.82				1711
50 x 5	34/100	61.25	U.D.L	381.50	244.00	153.64	82.93	48.61	39.35	19.91	13.60	9.60	6.97	5.18	3.93	3.04	2119	
			C.L	32.03	24.61	19.97	12.92	8.62	6.04	4.39	3.30	2.54	1.99	1.59	1.30	1.07		2138
60 x 5	34/100	73.03	U.D.L	549.47	351.47	243.91	143.30	84.00	52.44	34.41	23.50	16.59	12.05	8.96	6.80	5.25	2429	
			C.L	46.14	35.46	28.78	22.33	14.90	10.43	7.59	5.70	4.38	3.44	2.76	2.24	1.84		2566

When using the load tables please consider the following notes:

1. Material grade S275JR, fy = 275N/mm² in accordance with BS EN 1993-1-1 (EC3).
2. Flooring panels simply supported.
3. The loads shown in the table are based upon the design strength divided by a partial safety factor, Q = 1.5, allowance for the self weight of the flooring has been included.
4. Deflections limited to L/200, 10mm or 4mm* whichever is the lesser. * The difference in level between loaded and unloaded neighbouring panels has been limited to 4mm in accordance with BS EN ISO 14122-2:2001+A1:2010 & BS 4592-0:2006+A1:2012. Should the neighbouring panels be secured together the 4mm deflection rule need not apply and larger spans may be achievable, contact our sales team for further information.
5. Serrated load bearing bars to provide enhanced slip resistance are available upon request, contact our sales team for further information.
6. All floor types with the exception of the 41mm pattern comply with clause 4.2.4.4 of BS EN ISO 14122-2:2001 and 5.1 of BS 4592-0:2006+A1:2012, where the maximum opening shall not permit the passage of a 35mm diameter sphere. Should the working platform be above a place where people are continuously working, as opposed to passing occasionally or on fire escapes then the maximum opening should not permit the passage of a 20mm diameter sphere and an alternative floor type / means of protection to prevent falling objects should be provided. For further information and advice please contact our sales team.
7. Values in red are below the required UDL or CL load requirements for general duty loading of table 1, BS 4592-0:2006+A1:2012.
8. U.D.L = Uniformly Distributed Load per square metre, kN/m². C.L = Concentrated load over 200mm x 200mm, kN.

Modular Access Systems

Industrial Flooring -Rectangular - Open Type Flooring



Rectangular Pattern Type 30/100 and 30/50

Load Bearing bars (mm)	Type	Mass kg/m ²	Load Type	Clear span (mm)												Max'm span (mm) for 5 kN/m ²	Max'm span (mm) for 1.5 kN		
				600	750	900	1050	1200	1350	1500	1650	1800	1950	2100	2250			2400	
20 x 3	30/100	18.53	U.D.L	25.39	13.00	6.69	3.61											968	
			C.L	2.36	1.48	0.91													
25 x 3	30/100	22.54	U.D.L	49.58	25.39	13.06	7.05	4.13	2.58									1114	
			C.L	4.61	2.90	1.77	1.11												943
25 x 5	30/100	35.69	U.D.L	82.64	42.31	21.76	11.75	6.89	4.30	2.82								1300	
			C.L	7.68	4.83	2.95	1.85	1.23	0.86										1118
30 x 3	30/100	26.54	U.D.L	85.68	43.87	22.57	12.18	7.14	4.46	2.92								1312	
			C.L	7.90	5.00	3.06	1.91	1.28	0.89										1131
30 x 5	30/100	42.37	U.D.L	142.80	73.11	37.61	20.30	11.90	7.43	4.87	3.33							1490	
			C.L	13.16	8.34	5.10	3.19	2.13	1.49	1.08	0.81								1341
35 x 3	30/100	30.54	U.D.L	127.04	69.66	35.83	19.34	11.34	7.08	4.64	3.17							1473	
			C.L	10.75	7.95	4.86	3.04	2.03	1.42	1.03	0.78								1320
35 x 5	30/100	49.04	U.D.L	211.75	116.10	59.72	32.24	18.90	11.80	7.74	5.29	3.73	2.71					1673	
			C.L	17.92	13.24	8.09	5.07	3.38	2.37	1.72	1.29	0.99	0.78						1565
40 x 3	30/100	34.55	U.D.L	165.97	103.98	53.49	28.87	16.92	10.57	6.93	4.73	3.34						1628	
			C.L	14.05	10.79	7.25	4.54	3.03	2.12	1.54	1.16	0.89							1509
40 x 5	30/100	55.71	U.D.L	276.63	173.31	89.15	48.12	28.21	17.61	11.55	7.89	5.57	4.05	3.01				1849	
			C.L	23.42	17.99	12.08	7.65	5.04	3.53	2.57	1.93	1.48	1.17	0.93	0.76				1789
50 x 5	30/100	69.06	U.D.L	432.37	276.64	174.12	93.99	55.09	34.39	22.57	15.41	10.88	7.90	5.87	4.46	3.44		2186	
			C.L	36.61	28.13	22.83	14.77	9.85	6.90	5.02	3.77	2.90	2.28	1.82	1.48	1.22			2236
60 x 5	30/100	82.40	U.D.L	622.73	398.33	22.83	162.41	95.20	59.43	38.99	26.63	18.80	13.65	10.15	7.70	5.95		2507	
			C.L	52.73	40.42	32.89	25.52	17.03	11.93	8.69	6.51	5.01	3.94	3.15	2.56	2.11			2683

*For mass Type 30/50 add 2.8 kg/m²

Modular Access Systems

Industrial Flooring -Rectangular - Open Type Flooring



Rectangular Pattern Type 41/100 and 41/50

Load Bearing bars (mm)	Type	Mass kg/m ²	Load Type	Clear span (mm)												Max'm span (mm) for 5 kN/m ²	Max'm span (mm) for 1.5 kN		
				600	750	900	1050	1200	1350	1500	1650	1800	1950	2100	2250			2400	
20 x 3	41/100	14.35	U.D.L	18.67	9.56	4.92	2.65											896	
			C.L	1.77	1.11														
25 x 3	41/100	17.30	U.D.L	36.46	18.67	9.60	5.18	3.04										1059	
			C.L	3.46	2.17	1.33	0.83												
25 x 5	41/100	26.97	U.D.L	60.76	31.11	16.00	8.64	5.06	3.16									1204	
			C.L	5.76	3.62	2.21	1.38	0.92											
30 x 3	41/100	20.24	U.D.L	63.00	32.26	16.59	8.96	5.25	3.28									1215	
			C.L	5.92	3.75	2.29	1.44	0.96											
30 x 5	41/100	31.88	U.D.L	105.00	53.76	27.65	14.93	8.75	5.46	3.58								1380	
			C.L	9.87	6.26	3.82	2.39	1.60	1.12	0.81									
35 x 3	41/100	23.18	U.D.L	93.41	51.22	26.35	14.22	8.34	5.20	3.41								1364	
			C.L	8.06	5.96	3.64	2.28	1.52	1.07	0.77									
35 x 5	41/100	36.79	U.D.L	155.69	85.37	43.91	23.70	13.89	8.67	5.69	3.89	2.74						1549	
			C.L	13.44	9.93	6.07	3.80	2.53	1.78	1.29	0.97								
40 x 3	41/100	26.13	U.D.L	122.03	76.46	39.33	21.23	12.44	7.77	5.10	3.48							1507	
			C.L	10.54	8.09	5.44	3.40	2.27	1.59	1.16	0.87								
40 x 5	41/1041	41.69	U.D.L	203.40	127.43	65.55	35.38	20.74	12.95	8.50	5.80	4.10	2.97					1713	
			C.L	17.56	13.49	9.06	5.67	3.78	2.65	1.93	1.45	1.11	0.87						
50 x 5	41/100	51.50	U.D.L	317.91	203.33	128.03	69.11	40.51	25.29	16.59	11.33	8.00	5.81	4.32	3.28	2.53		2025	
			C.L	27.46	21.10	17.12	11.08	7.39	5.18	3.77	2.83	2.17	1.71	1.37	1.11	0.91			
60 x 5	41/100	61.32	U.D.L	457.89	292.89	203.26	119.42	70.00	43.70	28.67	19.58	13.83	10.04	7.46	5.66	4.38		2321	
			C.L	39.55	30.39	24.67	19.14	12.77	8.94	6.51	4.88	3.76	2.95	2.36	1.92	1.58			

*For mass Type 41/50 add 2.8 kg/m²

Modular Access Systems / GPR System

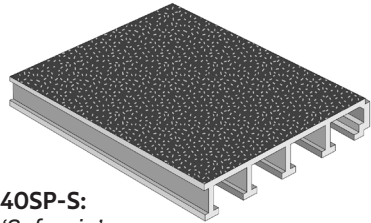

40SP-S:
'Safegrip'

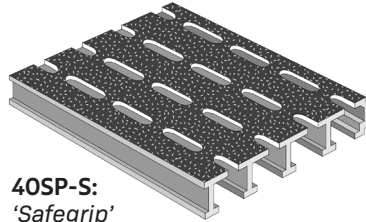

40SP-S:
'Safegrip'

Complete support structures are available constructed from GRP sections with stainless steel fixings, in both fire and non fire retardant GRP materials

The benefits of GRP materials are numerous;

- High strength
- Low weight
- Corrosion resistance
- Low maintenance
- Low conductivity to heat and electricity
- Non magnetic
- Non sparking

GRP 'Safegrip' Stairtreads

Stairtreads from GRP grating / solid have a square sitting bar to the front of the tread which also acts as a high stress absorber where most of the force is applied in use. The sitting bar is of a contrasting colour, normally yellow.

GRP 'Safegrip' Planking

Solid (40SP-S) or perforated (40SP-P) from stock in 6m x 500m panels or cut to size and shape. Adjacent panels connect by tongue and groove joints. Supplied with a plain or gritted top walking surface. Fixings are stainless steel.

GRP Moulded Gratings

Available 25mm or 40mm thick in stock panels 1.22m * 2.44m having a 40mm square perforated grid pattern. With plain or gritted slip resistant top walking surface.

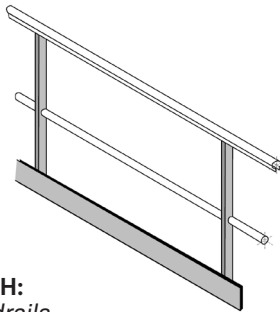

GPR-H:
Handrails

- Light, medium and heavy duty designs
- Posts are square or rectangular sections
- Contrasting colour posts and rails available
- With or without kickplate
- Supplied in kit form for ease of installation.

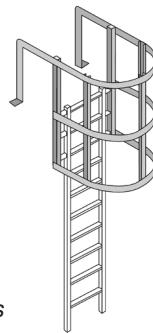

GPR-L:
Ladders

- Stringers are square or rectangular hollow sections for greater stiffness and strength
- Serrated rungs offer good grip
- Contrasting colours for rungs and stringers available
- Complete with GRP safety cages where required
- Stays and feet in GRP or stainless steel to suit