

Revolution® 75 Series High-Volume, Low-Speed (HVLS) Fan

Now cooling with direct drive technology.



Performance

- » Improve productivity by providing evaporative cooling
- » Exclusive Propell-Aire™ aluminum blades with standard mill finish. Incorporates tilt, taper, and twist to produce consistent airflow across the entire length of the blade, eliminating pockets of stagnant air under the center of the fan
- » Covers 31,000 sq. ft., moving air up to 100 ft. in all directions from the center of the fan

Construction

- » Vibration-dampening material is incorporated to reduce stress to the hub by 50 to 75%
- » The blade and hub are balanced for smooth, efficient performance
- » Maximum weight is 250 lbs. Actual weight varies according to the fan size and mounting style
- » Backed by Rite-Hite's 50 year track record as an industrial manufacturer

NOTE: Fan assembly is pre-wired with a NEMA twist-lock plug and 5' cord.

Safety

- » All fans feature a hub to motor connection with redundant safety cable, stabilizing cables, and mounting bracket
- » A unique safety system is provided for back-up security for the motor to hub connection

Warranties

- » 3 year parts & 3 year labor warranty
- » 10 year structural integrity warranty
- » Lifetime warranty on workmanship of blades and interlocking fan arms
- » 12 month limited money-back guarantee
- » Listed to UL507 Standard

Direct Drive Motor

- » Motor is nearly silent operating between 38 to 42 dBA, depending on fan speed. Ideal for environments with sound concerns
- » Direct drive design does not require oil
- » Simplified design reduces installation time and costs

Wireless Controls

- » Customizable 7-day scheduling. Manage up to 24 fans from the wireless touch screen control station
- » Standard Ethernet connectivity allows remote access to fan controls from a PC or mobile device



Fan-Commander®

NOTE: Control box ships standard with connection locations to receive a low voltage stop signal from a fire panel to comply with NFPA 13

Specifications/Survey

Fan Dimensions and Mounting Guidelines

REVOLUTION
75 SERIES

Date _____

Company Name _____

Address _____

City _____

State _____ Zip Code _____

Representative _____

Salesperson _____

Quantity _____ Signature _____

Fan Diameter:

- 8' (2440 mm)
- 12' (3660 mm)
- 16' (4880 mm)

Mounting Option:

- I-Beam Bracket
- Truss Kit

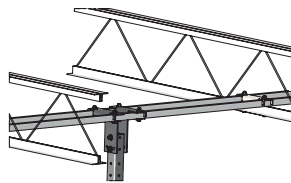
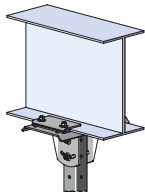

- Purlin Kit
- Laminated Beam Kit

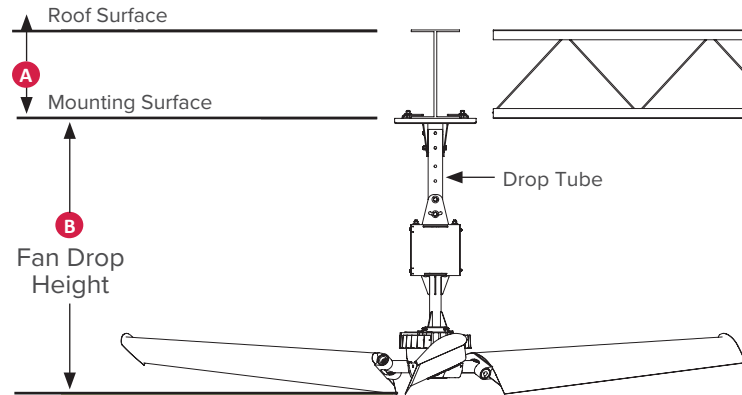
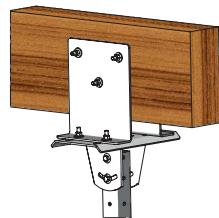
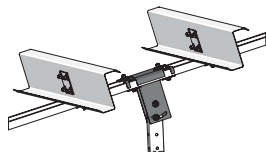

B Fan Drop Height (See Chart):

- 43" (1100 mm) (No Drop Tube)
- 56" (1430 mm)
- 68" (1730 mm)
- 86" (2190 mm)

Drop tubes may be cut on site to decrease Fan Drop Height. See the Owner's Manual for cut lengths and fan clearances.

Voltage/Phase:

- 200-240V / 1 phase
- 200-240V / 3 phase
- 277V / 1 phase
- 400-480V / 3 phase

600 Volt Transformer:

- No
- Yes (requires 480V / 3 phase)

EMC Compliance:

- No
- Yes

Shipment Destination:

- North America
- International

Custom Color: Blades and Hub:

- No. Standard Mill Finish
- Yes.
RAL K5# _____ (20% gloss)

A Roof Surface to Mounting Surface	B Fan Drop Height <i>Minimum height required for air intake</i>		
	8' Fan Diameter	12' Fan Diameter	16' Fan Diameter
0" - 18" (0 mm - 457 mm)	43"	43"	56"
19" - 48" (483 mm - 1210 mm)	43"	43"	43"

Minimum Fan Drop Height assumes a flat roof surface. Fan Drop Height may need to be increased for roofs with a steeper pitch.

Note: Controls are not included. Please order Fan-Commander® separately.

RITEHITE
ALWAYS LOOKING AHEAD

Milwaukee, Wisconsin, USA

www.ritehite.com

P 414-355-2600 (800-456-0600)

F 414-355-9248

Rite-Hite®, Fan-Commander®, Propell-Aire™ and Revolution® are trademarks of Rite-Hite Holding Corporation. Rite-Hite products may be covered by one or more U.S. Patents with other U.S. and foreign patents pending. Patent coverage: www.ritehite.com/patents. The information herein is provided as a general reference only regarding the use of the applicable products. The specifications stated here are subject to change. Manufactured by Rite-Hite Engineered Solutions Group, Inc.