

GateKeeper® Mezzanine Safety Gate

Ensure full time safety at the edge of a mezzanine.



Mezzanine and Elevated Platform Barriers

As companies look to maximize existing space within their facilities, many are turning to mezzanines, elevated work platforms, or multi-level racking systems to create additional storage space or work areas for employees.

These multi-level work environments allow companies to expand usable floor space

above existing operations. In many cases, expanding “up” is less costly and time-consuming than expanding “out,” which usually means adding onto existing space, leasing new space or constructing a new facility.

Meets applicable OSHA, ANSI and IBC standards

- » Designed to support compliance with applicable OSHA standard 1910 Subpart D, helping provide continuous fall protection for employees on walking-working surfaces. This includes any surface higher than 4' (1200 mm) above lower level
- » Developed in alignment with industry-recognized ANSI best practices for fall protection and open-edge guarding reinforcing a strong safety culture
- » Where building code requirements apply, guardrail design aligns with commonly adopted IBC provisions for guard height, strength and opening limitations, helping prevent falls from elevated surfaces

Features

- » Exclusive Saf-T-Latch prevents workers from raising the gate from the mezzanine side, helping prevent falls during the loading and unloading process
- » Unique link bar design ensures both gates move in unison to maintain full-time fall protection
- » Patent-pending spring lift reduces operator strain while maintaining durability
- » Toeboard helps prevent materials from being pushed off elevated platforms to a lower level
- » 3" (75 mm) galvanized track and nylon rollers provide smooth, consistent gate motion
- » Steel side frames provide built-in track protection
- » Optional powered push-button model improves ergonomics and offers effortless operation for larger gate sizes

Specifications/Survey

Date _____

Company Name _____

Address _____

City _____

State _____ Zip Code _____

Representative _____

Salesperson _____

Quantity: _____ Signature: _____

Specifications:

- » 10 Gauge Steel Frame Powder Coat Yellow
- » 4" (100 mm) Wide x 8.375" (215 mm) Deep Vertical Frames
- » 6" (150 mm) Formed Front & Side Headers
- » 4" (100 mm) Integral Toe Boards
- » Front Rails Heights of 21" (535 mm) and 42" (1065 mm) per OSHA 1910 Subpart D
- » 3" (75mm) Galvanized Steel Roller Track with Nylon Wheels
- » Manual GateKeeper includes Saf-T-Latch with Two Hand Operation

GateKeeper with Operator:

- » Operator 120V / 1 phase
- » Field Installed Left or Right
- » Open / Stop / Close Buttons with Photoeyes
- » #40 Chain and Sprocket Trolley System
- » Additional Side Clearance Required



10ISGGKSS0326AMEN03

Milwaukee, Wisconsin, USA

www.ritehite.com

P 414-355-2600 (800-456-0600)

F 414-355-9248

GateKeeper

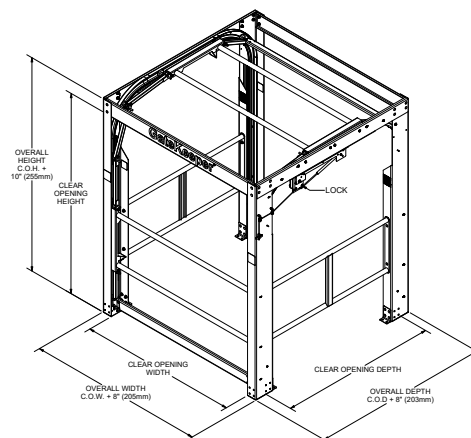

GateKeeper with Operator

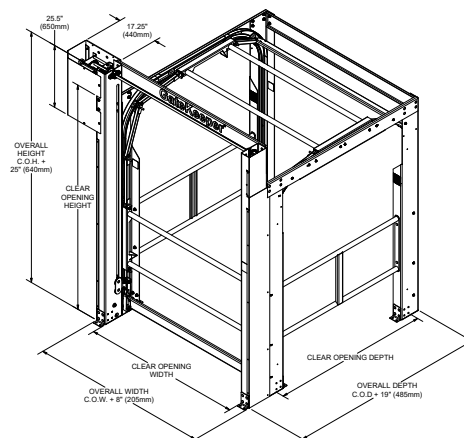

Clear Opening Width:

- Single Pallet Width: 5'6" (1675 mm)
 - Double Pallet Width: 8'6" (2590 mm)
 - Other Pallet Width: _____ ft _____ in OR _____ mm
- Acceptable Clear Opening Width: 4'0" to 8'6" (1220 to 2590 mm)

Clear Opening Height:

- Standard Height: 6'8" (2030 mm)
 - Other Pallet Height: _____ ft _____ in OR _____ mm
- Acceptable Clear Opening Height: 5'10" to 9'0" (1778 to 2745 mm)

Clear Opening Depth:

- Single Pallet Depth: 5'6" (1675 mm)
 - Double Pallet Depth: 8'6" (2590 mm)
 - Other Pallet Depth: _____ ft _____ in OR _____ mm
- Acceptable Clear Opening Depth: 4'0" to 8'6" (1220 to 2590 mm)

Operator*: YES NO

**If GateKeeper is being sold with an operator outside the United States, consult Applications. Extended lead times will apply.*

Rite-Hite® and GateKeeper® are trademarks of Rite-Hite Holding Corporation. Rite-Hite products may be covered by one or more U.S. and/or foreign patents and patents pending, with patent coverage information available at www.ritehite.com/patents. The information herein is provided as a general reference only regarding the use of the applicable products. The specifications stated here are subject to change. Copyright 2026. All rights reserved.