

4

3

2

1

OPTIONAL VERTICAL SUPPORT

OPTIONAL VERTICAL SUPPORT

OPENING WIDTH

HEADER

REVISION HISTORY

REV.	DATE	NOTE	ECN	BY
F	6/17/2019	CONVERT TO SOLIDWORKS	7766	SHC

SPECIFICATIONS:

SIZE LIMITS	MINIMUM WIDTH: 24" [610mm]
	MINIMUM HEIGHT: 24" [610mm]
	MAXIMUM WIDTH: 144" [3,658mm]
	MAXIMUM HEIGHT: 144" [3,658mm]
CURTAIN MATERIAL	40 MIL ORANGE PVC 35 OZ BLACK SUPERWEAR
PNEUMATIC CYLINDER	1" [25mm] BORE RODLESS BAND SEALED CYLINDER
HEADER MATERIAL	2" [51mm] x 4" [102mm] ALUMINUM EXTRUSION
OPTIONAL EXTENDED CURTAIN NOSE	NONE (SHOWN); 2" [51mm]; 6" [152mm]
OPTIONAL 24VDC JUNCTION BOX	SIZE: 10 1/2" [267mm] x 8 1/2" [216mm] x 6 1/4" [159mm] WITH TERMINAL BLOCKS AND 24VDC 4 WAY CONTROL VALVE
OPTIONAL 110VAC JUNCTION BOX	SIZE: 10 1/2" [267mm] x 8 1/2" [216mm] x 6 1/4" [159mm] WITH TERMINAL BLOCKS AND 110VAC 4 WAY CONTROL VALVE
OPTIONAL 110VAC CONTROL BOX	SIZE: 10 1/2" [267mm] x 8 1/2" [216mm] x 6 1/4" [159mm] WITH OPEN, STOP & CLOSE PUSHBUTTONS AND 110VAC 4 WAY CONTROL VALVE
OPTIONAL PROXIMITY SWITCHES	STORAGE POSITION; EXTENDED POSITION 24VDC, N/O CONTACT, PNP, M8x1-3PIN PLUG
OPTIONAL PROXIMITY SWITCH CABLES	STORAGE POSITION: M8x1-3PIN x 197" [5,000mm] EXTENDED POSITION: M8x1-3PIN x 394" [10,000mm]

B

B

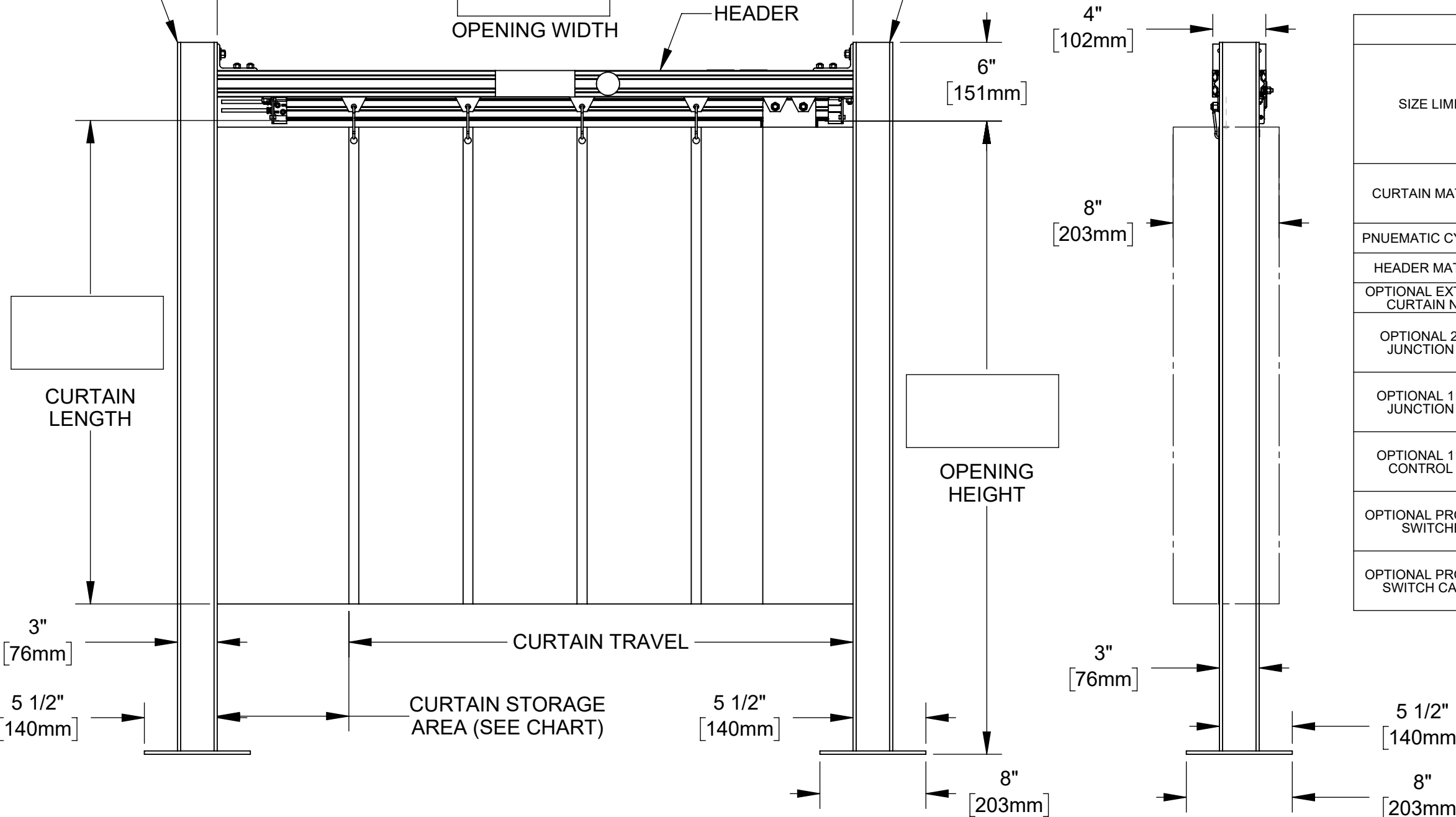

CURTAIN STORAGE AREA**	OPENING WIDTH
15" [279mm]	24" [610mm] ≤ DOW < 27" [686mm]
17" [330mm]	27" [686mm] ≤ DOW < 49" [1,245mm]
19" [381mm]	49" [1,245mm] ≤ DOW < 70" [1,778mm]
21" [432mm]	70" [1,778mm] ≤ DOW < 91" [2,286mm]
25" [483mm]	91" [2,286mm] ≤ DOW < 113" [2,870mm]
27" [533mm]	113" [2,870mm] ≤ DOW < 134" [3,404mm]
29" [584mm]	134" [3,404mm] ≤ DOW ≤ 144" [3,658mm]

\*\*ADD EXTENDED CURTAIN NOSE LENGTH, IF CHOSEN

A

A

SINGLE VERTICAL SUPPORT

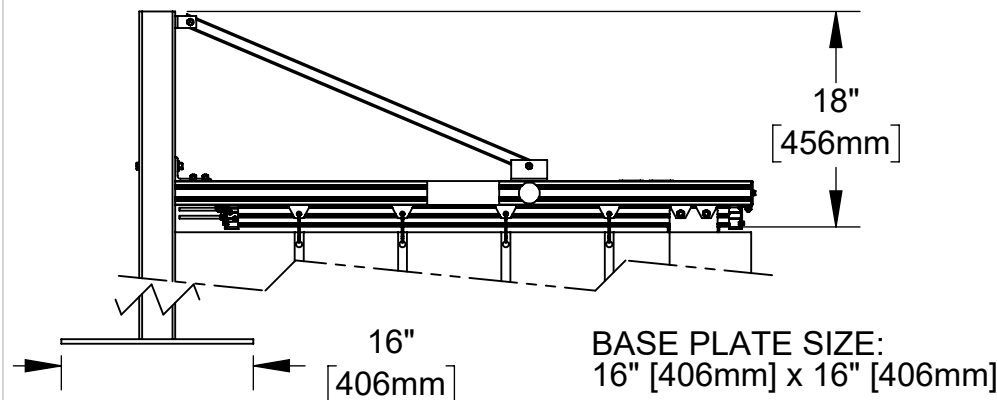

FINISH

UNLESS OTHERWISE SPECIFIED DIMENSIONS ARE IN INCHES.

TOLERANCES:

.X = ±.050  
.XX = ±.010  
.XXX = ±.005  
ANGLE = ±1.0°

THIRD ANGLE PROJECTION

© 2010 RITE-HITE® DOORS INC.

MATERIAL

DRAWN BY SHC  
DRAWN DATE 06/12/2019  
INITIAL ECN 7766  
DATE ISSUED 6/17/2019

REFERENCE

ALL SHEETS ARE THE SAME REVISION STATUS

DO NOT SCALE DRAWING

**RITE-HITE® DOORS INC.**

TITLE ARCHITECTURAL APPROVAL DRAWING SLIDE AIR - STATIONARY

SIZE MODEL DWG NO REV  
B SLDAIR 5220A001 F

SCALE 1:9 PART# SHEET 1 OF 1

4

3

2

1