

Model: FSTX

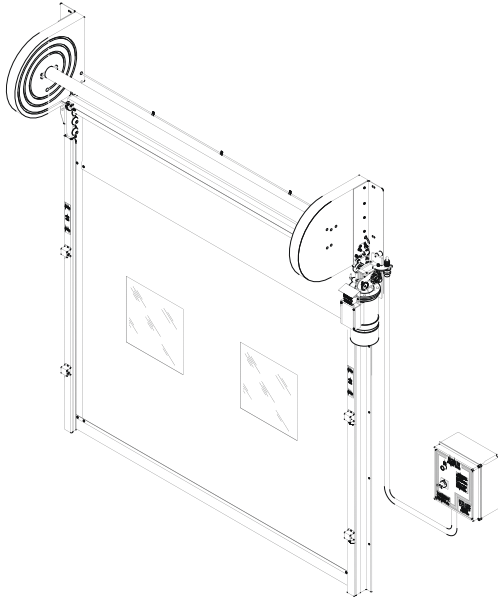

Model: FSTXLD (Large Driver)

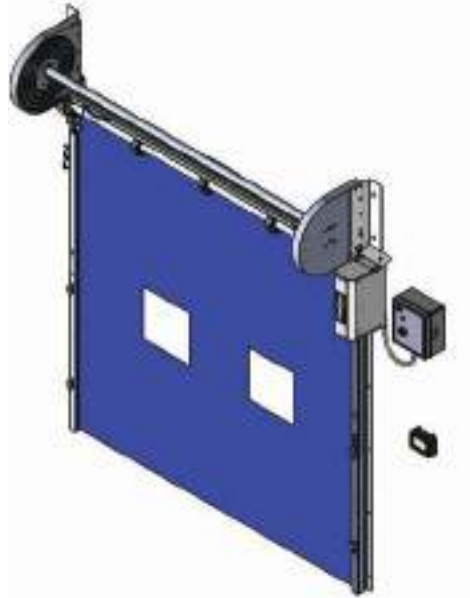

Model: FSTXFR (Freezer)

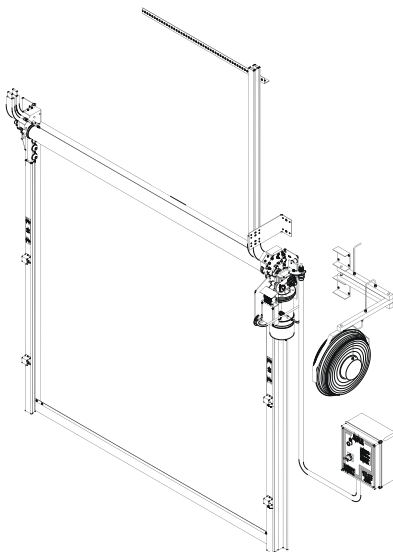

Model: FSTXFRLD (Freezer/Large Driver)



NOTICE TO USER	3	TROUBLESHOOTING	73
SAFETY	4	PARTS	
FEATURES	6	Control Box (FSTX/FSTXLD)	76
INSTALLATION		Control Box (FSTXFR/FSTXFRLD)	77
Preparation	7	Virtual Vision/Curtain Fan Junction Box	78
Door Jamb	8	Miscellaneous	80
Mounting Methods	10	Drive System (FasTrax, FasTrax FR)	82
Lower Track	18	Drive System (FasTrax LD, FasTrax FR LD)	84
Perimeter Seal (FasTrax FR, FasTrax FR LD)	20	Curtain	86
Upper Track	23	Tracks, Spreader Bar	87
Drive Tube	31	Photoeye	87
Motor/Encoder (FasTrax, FasTrax FR)	32	Drive Tube Assembly	87
Motor/Encoder (FasTrax LD, FasTrax FR LD)	34	Lower Track Assembly, Radial	88
Motor Phasing	35	Brackets, Guards	88
N.P.O. (Non-Powered Opening) (OPTIONAL)	36	Track, Re-feeds, Kits	89
Power Outage Procedure	39	Drive Cage	89
Curtain	40	Radial Center Shroud (FasTrax, FasTrax LD)	90
Electrical	42	N.P.O.	90
Doors Less than 8ft 0in [2438mm] D.O.H.	59	Upper Track	91
Poly Lumber (FasTrax FR, FasTrax FR LD) (OPTIONAL)	60	ABBREVIATIONS	92
Poly Lumber (FasTrax, FasTrax LD) (OPTIONAL)	61	WARRANTY	96
Radial Center Shroud (FasTrax, FasTrax LD) (OPTIONAL)	62		
Weld Plate (OPTIONAL)	63		
Wireless Activation (OPTIONAL)	64		
Labels/Shrouds	65		
Final Checklist	66		
OPERATION			
Close, Stop, and Open	67		
Security	67		
Common Locations (i-COMM 3)	68		
Common Tasks (i-COMM 3)	68		
Verify Operation	69		
Photoeye Adjustment	69		
Power Outage Procedure	69		
MAINTENANCE			
Planned Maintenance	70		
Encoder Replacement	71		
Drive Sphere Replacement	71		
Retention Strip Replacement	71		
Gearbox Oil	72		

NOTICE TO USER

Thank you for purchasing a Rite-Hite product.

FasTrax High Speed Doors are fabric doors that help to maintain and separate different atmospheres.

The information in this manual applies to FSTX, FSTXLD, FSTXFR and FSTXFRLD, unless otherwise noted.

Read and understand manual before beginning the installation, operation or servicing of this door.

Before work begins, verify space clearance requirements from architectural drawings.

Use i-COMM™ 3 manual with this manual for complete installation and operation instructions.

Complete "**Final Checklist**" [page 66](#) before leaving site.

Store manual near the unit.

The English version of this manual shall prevail over any error in, or conflicting interpretation of, any translations.

Rite-Hite reserves the right to substitute and/or modify parts and drawings (electrical and architectural) from those contained in this manual. Separate prints may be included with the unit.

When ordering parts, include your door serial or RHC number located on the label on the lower track.

For best results, have this product serviced by an authorized Rite-Hite representative.

A Planned Maintenance Program (P.M.P.), customized to your specific operation is available and recommended.

For a P.M.P., contact your local Rite-Hite representative or Rite-Hite technical support at (U.S.) 1-563-589-2722, 1-888-456-3625, (S.A.) +55 21 99616 4421, (E.U.) +49-5693 98700.

NOTICE

Store dry between 40° and 80° F, [4° and 27° C].

The Rite-Hite® products in this manual are covered by one or more of the following U.S. patents: 6192960, 6212826, 6330763, 6360487, 6481487, 6560927, 6598648, 6615898, 6688374, 6837296, 6901703, 6964289, 7034682, 7045764, 7111661, 7114753, 7151450, 7578097, 7699089, 7748431, 7757437, 8037921, 8167020, 8113265, 8863815, 8857498, 9222304, 9388634, 9309717, 9493984, 9556672, 9631427, 9771754 and may be covered by additional pending U.S. and foreign patent applications.

Rite-Hite®, i-COMM™, FasTrax®, FasTrax® FR, FasTrax® FR LD, FasTrax® LD, FasTrax® Washdown, FasTrax® XL are trademarks of Rite-Hite.

Manufactured by Rite-Hite Doors, Inc.

FCC Compliance

NOTE: This equipment has been tested and found to comply with the limits for a Class A digital device, pursuant to Part 15 of the FCC Rules. These limits are designed to provide reasonable protection against harmful interference when the equipment is operated in a commercial environment. This equipment generates, uses, and can radiate radio frequency energy and, if not installed and used in accordance with the instruction manual, may cause harmful interference to radio communications. Operation of this equipment in a residential area is likely to cause harmful interference in which case the user will be required to correct the interference at his own expense.

NOTE: Changes or modifications not expressly approved by the party responsible for compliance could void the user's authority to operate the equipment.

This device complies with Part 15 of the FCC Rules. Operation is subject to the following two conditions:

1. This device may not cause harmful interference.
2. This device must accept any interference received, including interference that may cause undesirable operation.

SAFETY

Safety Identifications

DANGER

Indicates a hazardous situation which, if not avoided, will result in death or serious injury.

Indique une situation dangereuse qui, si elle n'est pas évitée, peut entraîner la mort ou de graves blessures.

WARNING/AVERTISSEMENT

Indicates a hazardous situation which, if not avoided, could result in death or serious injury.

Indique une situation dangereuse qui, si elle n'est pas évitée, peut entraîner la mort ou des blessures graves.

CAUTION/ATTENTION

Indicates a hazardous situation which, if not avoided, could result in minor or moderate injury.

Indique une situation dangereuse qui, si elle n'est pas évitée, peut entraîner des blessures légères à modérées.

NOTICE

Indicates a situation which can cause damage to the equipment, personal property and/or the environment, or cause the equipment to operate improperly.

NOTE: A note is used to inform you of important installation, operation, or maintenance information.

Lockout Procedure

Barricade work area and post safety warnings.

Power supply and control must:

- Be disconnected or locked in OFF position using a lockout device approved by local codes.
 - Have signage that;
 - Clearly states repairs are being made.
 - Identifies person responsible for lockout condition.
- NOTE:** Only this person should be able to remove warnings and lockout device.
- Withstands environmental conditions (weather, wet, and damp, etc.) and remains readable.

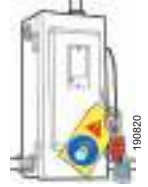

General

DANGER

A qualified electrician should install the wiring in accordance with local electrical codes.

Use lockout procedures to prevent death or severe personal injury.

L'installation du câblage doit être effectuée par un électricien qualifié, conformément aux normes électriques nationales et locales.

Afin de réduire le risque de blessures graves ou mortelles, utilisez des procédures de verrouillage.

DANGER

To reduce risk of injury or death, an earth ground connection must be made to the green/yellow control box ground terminal.

If metal conduit is used as the ground connector, a ground bushing and green/yellow wire must be properly attached to the conduit for connection to the ground terminal, per local electrical codes.

Pour réduire le risque de blessures ou de décès, un raccordement de terre doit être fait à la boîte de contrôle verte/jaune de la borne de terre.

Si le connecteur de terre utilisé est un conduit métallique, un manchon de mise à la terre et un câble vert/jaune doivent être correctement fixés au conduit un raccordement à la borne de terre, par codes électriques locales.

SAFETY

General *Continued*

WARNING/AVERTISSEMENT

Failure to restrict the curtain speed can result in damage to product or injury to personnel. The curtain may close very quickly if the brake is fully released.

Partially release the brake to close the door smoothly.

Le non-respect de restreindre le rideau vitesse peut entraîner des dommages au produit ou blesser le personnel. Le rideau peut fermer très rapidement si le frein est complètement desserré.

Relâchez partiellement le frein pour fermer la porte en douceur.

WARNING/AVERTISSEMENT



**STAND CLEAR!
TENEZ-VOUS À L'ÉCART**

Rapid moving door could cause serious injury or death.

La porte mobile rapide peut causer des blessures graves ou la mort.

Door could close automatically.

La porte peut se fermer automatiquement.

DO NOT stand in the doorway, and **DO NOT** walk under moving door. Keep door in full view and free of obstructions while operating.

NE PAS rester debout dans la porte et **Ne PAS** marcher sous la porte mobile. Garder la porte en pleine vue et sans obstruction pendant l'opération.

Repairs or adjustments should be made only by a trained door systems technician.

Les réparations ou les ajustements ne doivent être effectués que par un technicien agréé.

WARNING/AVERTISSEMENT

The Variable Frequency Drive (in control box) has a stored charge, it is unsafe to work on for 10 minutes after disconnecting power.

Le variateur de fréquence (dans la boîte de contrôle) a une mémoire de charge, il est dangereux de travailler pendant 10 minutes après la coupure de l'alimentation.

WARNING/AVERTISSEMENT

Cancer and Reproductive Harm
www.P65Warnings.ca.gov

Canver al problèmes du système de reproduction
www.P65Warnings.ca.gov

CAUTION/ATTENTION

During installation and repair, barricade both sides of the door to prevent unauthorized use.

Pendant l'installation et la réparation, délimitez et protégez les deux côtés de la porte pour éviter toute utilisation non autorisée.

NOTICE

The safest location for conduit is at the bottom of the control box. Failure to install conduit at the bottom of the control box may void the warranty.

Be extremely careful when drilling conduit holes into the control box. Drilling too deeply or allowing debris to fall into electrical components may cause severe equipment damage or component failure.

DO NOT turn control box upside down when drilling holes. Holes on top of control box may allow dust and moisture to enter the control box.

NOTICE

In freezer and cooler applications where a conduit passes from a warm to cold temperature zone, the conduit must be sealed with an approved material per local electrical codes.

FEATURES

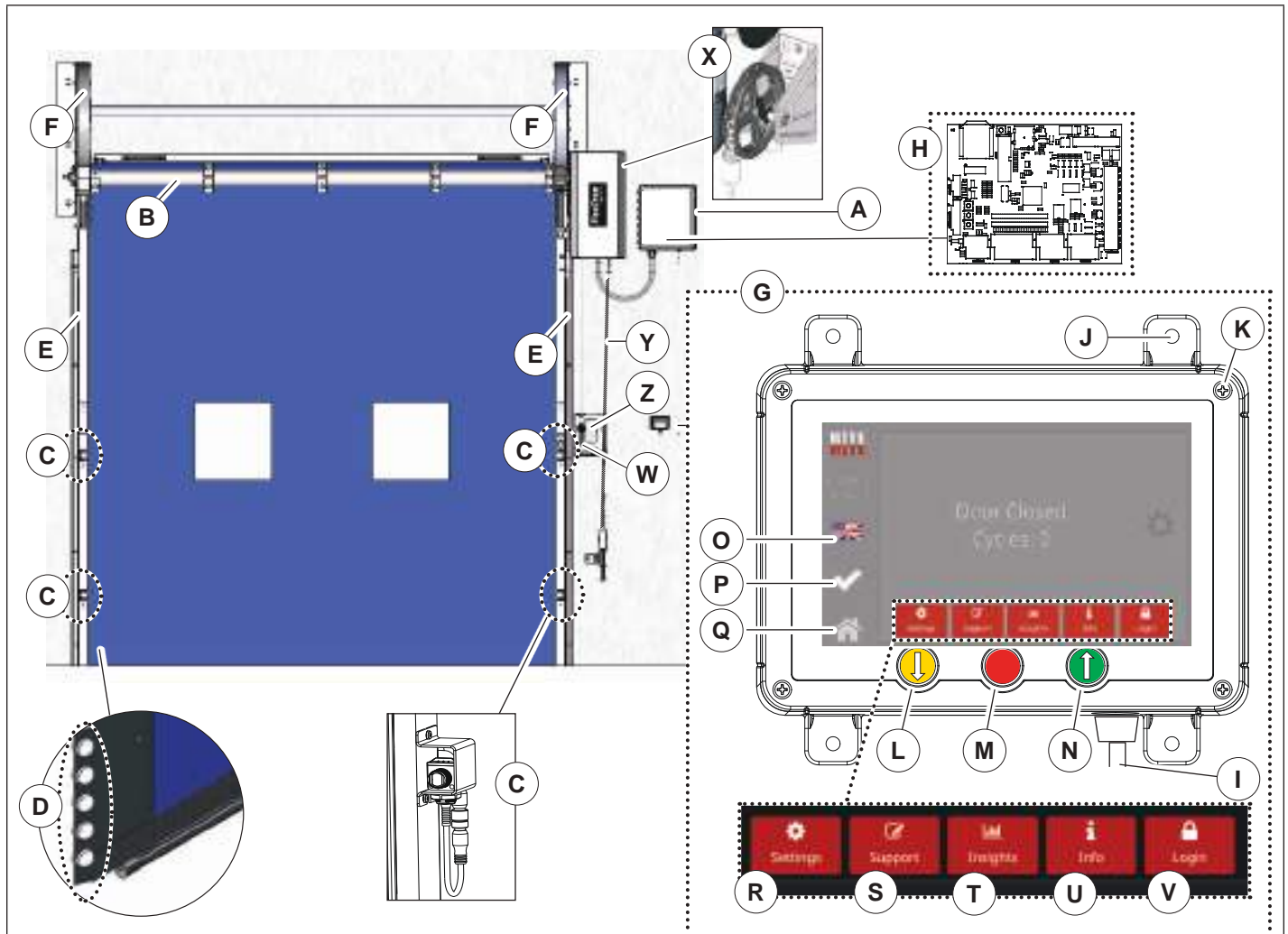

- A. Control Box
Serial Number Label
- B. Drive Tube
- C. Photoeye
- D. Spheres
- E. Lower Track
- F. Upper Track
(may be radial in design)
- G. Touch Screen Controls/GUI
- H. i-COMM 3
- I. Communication Cable
- J. Wall Attachment (x4)
- K. Enclosure screw (x4)

Buttons:

- L. Close (Yellow)*
- M. Stop (Red)*
- N. Open/Reset (Green)*
- O. Language indicator
- P. Door Status:

	Red	Fault
	Yellow	Warning
	White	Operating Normally

- Q. Home
- R. Settings**
- S. Support**
- T. Insights**
- U. Info**
- V. Login**

Optional:

- W. Brake Release Lever
- X. Non-Powered Opening (N.P.O.)
- Y. N.P.O. Hand chain
- Z. N.P.O. Label
(operating instructions)

Shown: FSTXLD
 *Buttons are mirrored on the i-COMM 3 for use during installation.
 **Conditional buttons. Shown: Home Screen.

Figure 1

INSTALLATION

Preparation

NOTE: Refer to i-COMM 3 Installation/Service manual for GUI/Touchscreen installation.

1. Check for electrical prints included in the parts or control box. They supersede any prints in this manual.
2. Alternate measurements in brackets are in [metric].
3. Make sure you are working at the correct location and have any required work permits.
4. Inspect installation site to make sure area is free of overhead obstructions (sprinkler pipes, HVAC systems, electrical supply lines, etc.) that might interfere with the lifting of the header assembly during installation.
5. Detour material handling equipment (fork lift trucks, etc.) during the installation of the door.
6. Make sure that the electrician is ready to bring the correct electrical power supply to the door control box.
7. Make sure that the electrical power can be shut off without interfering with other plant operations.
8. Move the entire crate of the door components as close to the door opening as possible.
9. If multiple doors are being installed, the control box must be installed with the matching door unit. The serial number for your door is on a label located on the side of the control box and side support post (**Figure 43 on page 44**).
10. To verify proper installation, use **"Final Checklist" on page 66**.
11. Install *Activation* and *Optional* equipment after verifying door operation.

Required Tools

Fork and scissors lift	Hammer drill (cordless or electric)
Level (laser or hydro)	25ft [8m] tape measure
Ladder 6ft-8ft [2m-2.5m]	Wire strippers (small-22 AWG [.64mm])
Utility knife	6ft [2m] carpenter's level
Electrical tape	Square/straight edge
Hammer	5/16in [10mm] nut driver
Plumb bob	"C" clamps
7/16in, 1/2in, 9/16in, 3/4in, 15/16in open end and/or socket wrench	
11/16in x 12in [17mm x 305mm] drill bit for through bolting	
Straight/Phillips screwdrivers (small 1/8in [3mm] spade)	
Phillips bit and drill bits for drill	
1/2in [13mm] masonry and/or drill bit for through bolting	
Allen wrench set (1/8in, 3/16in, 5/32in, 1/4in, 2mm)	
Stainless steel mounting hardware (supplied by others)	

INSTALLATION

Door Jamb

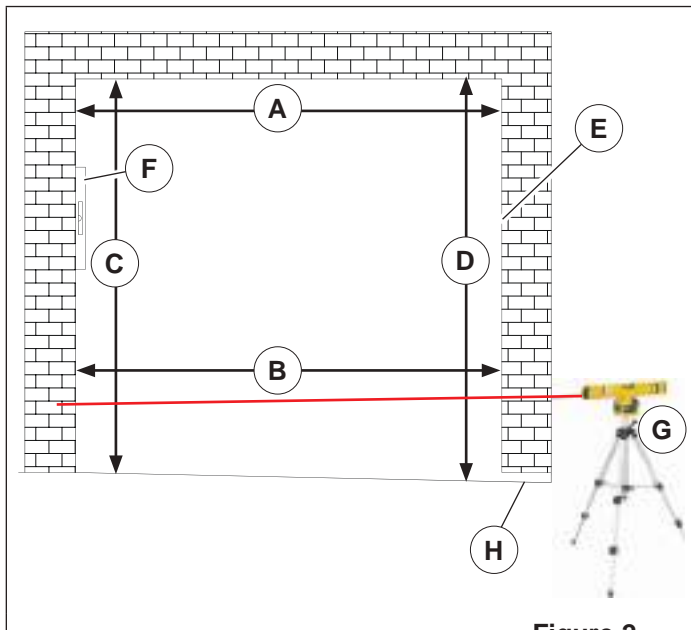

Figure 2

NOTE: For space clearance requirements, refer to architectural drawings (sent with unit) or call your Rite-Hite Representative.

1. Measure Door Opening Width (D.O.W.) at the top (A) and floor (B).
2. Measure Door Opening Height (D.O.H.) at left side (C) and right side (D).
3. Dimensions from Steps 1-2 should be $\pm 1/2$ in [13mm] of the dimensions listed on the serial number label. If the measurements do not agree, STOP! Contact your Rite-Hite representative.
4. Surface MUST be flat, smooth and on the same plane with opposite side (E).
5. Using a 6ft [2m] carpenter's level (F), verify that the door jambs and header are plumb and perpendicular.
6. Using a laser level (G), place a mark where the laser is sighted on each side of the jamb to determine if the floor is level. Measure both sides from floor to the mark and if the floor is not level to $\pm 1/8$ in [3mm], shim under the lower track that will be located on the low side (H) (greatest measurement) of the door opening.

INSTALLATION

Mounting Methods

Acceptable Anchor Types

These anchor types provide the necessary strength for secure attachment of the unit to the building wall.

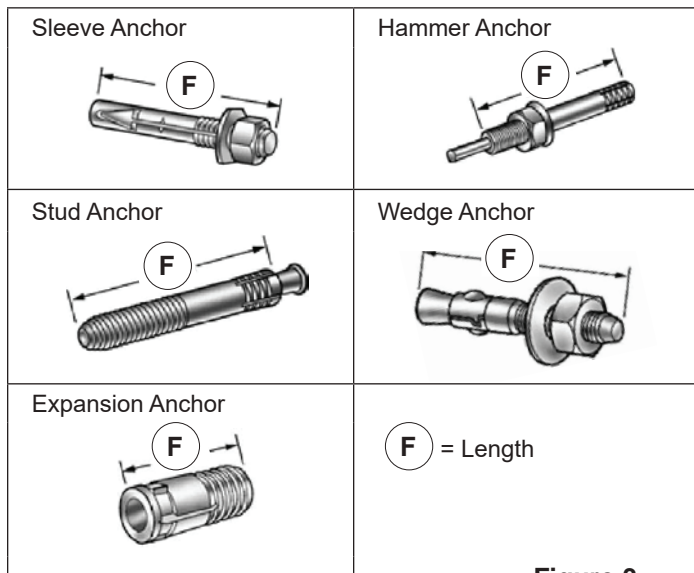

Figure 3

Length of anchor should be long enough to engage concrete structure by a minimum of 2in [51mm]. Length should be increased to allow anchor to extend through any brick or aggregate fascia on exterior into concrete structure a minimum of 2in [51mm].

Unacceptable Anchor Types

These anchor types are not strong enough for this application and do not provide the ability to tightly secure the unit to the building wall.

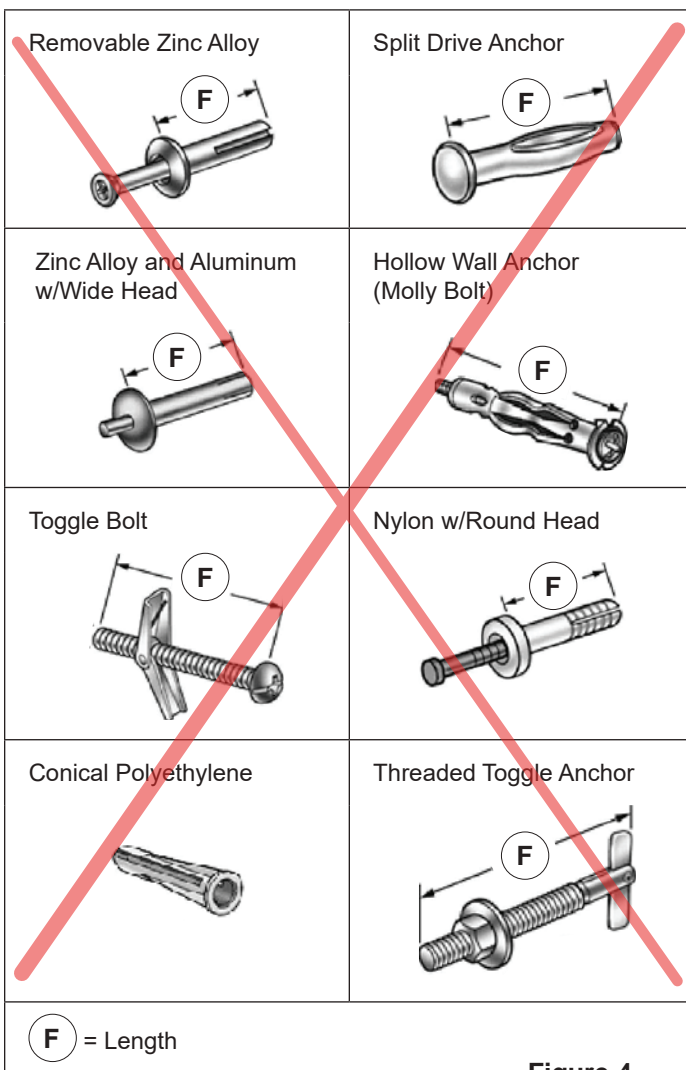

Figure 4

INSTALLATION

Mounting Methods *Continued*

Acceptable Fasteners



<p>Threaded rods can be used and cut to length in the field to suit the application.</p> 
<p>Hex head bolts can be used, but length must be determined ahead of time to make sure fasteners will work with application.</p> 
<p>Wall Sleeve 3/8in [M10] ID Ø</p> 
<p>Backer Plate 1/8in x 6in [3mm x 152mm] Ø</p> 

Figure 5

Typical Fastener Spacing

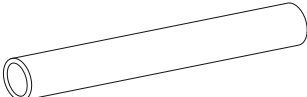
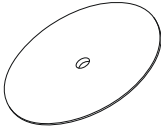
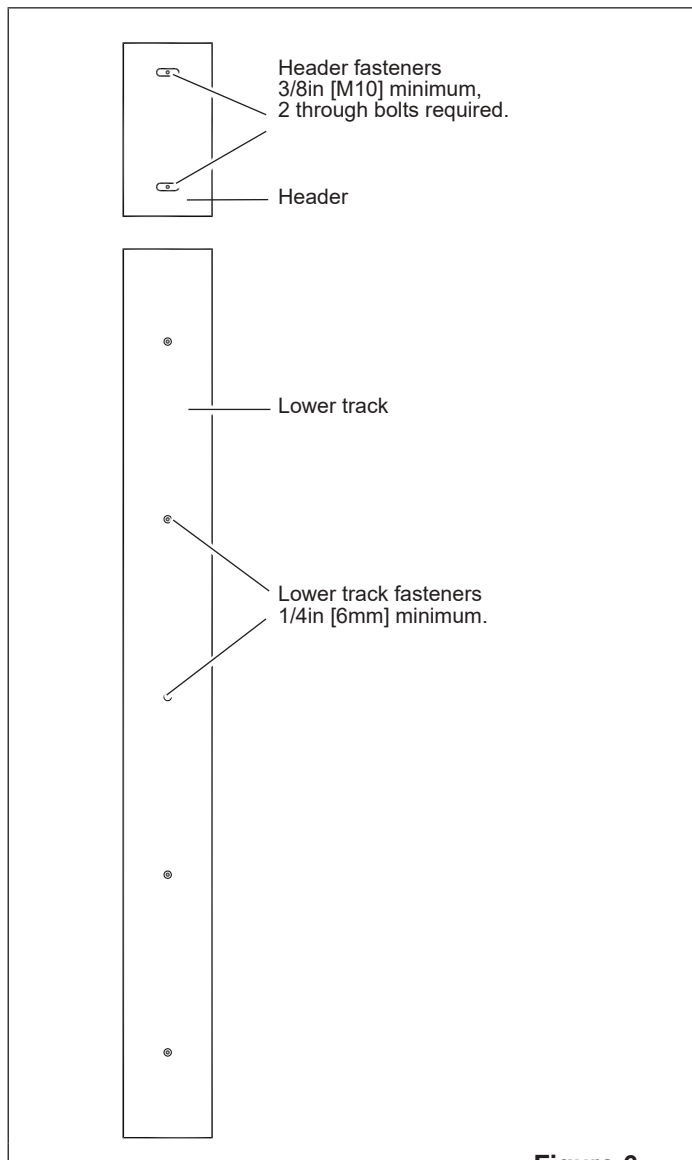

Figure 6

Walls constructed of wood, dry wall, stone block, or insulation require further jamb preparation.

The fastening method, is the responsibility of the installer. It requires the door to remain attached to the wall if, for example, a door fails to open when a vehicle approaches and impacts the non-mounted side. Lower tracks are required to be through bolted a minimum of every 4ft [1.2m] with 1/4in [M6] minimum fasteners filling in the remaining holes (**Figure 6**).

Wall sleeves and backer plates (**Figure 5**) may be required if wall crushes when fasteners are tightened.

Backer plates (if used) must be clean and either painted or a non-ferrous material.

INSTALLATION

Mounting Methods *Continued*

NOTICE

Wall material and mounting surface must be strong enough to support the weight of the door assembly in addition to lateral loads that the door assembly may be subjected to.

Through bolts must be used with concrete block and brick walls. **DO NOT** use anchors.

Concrete Wall

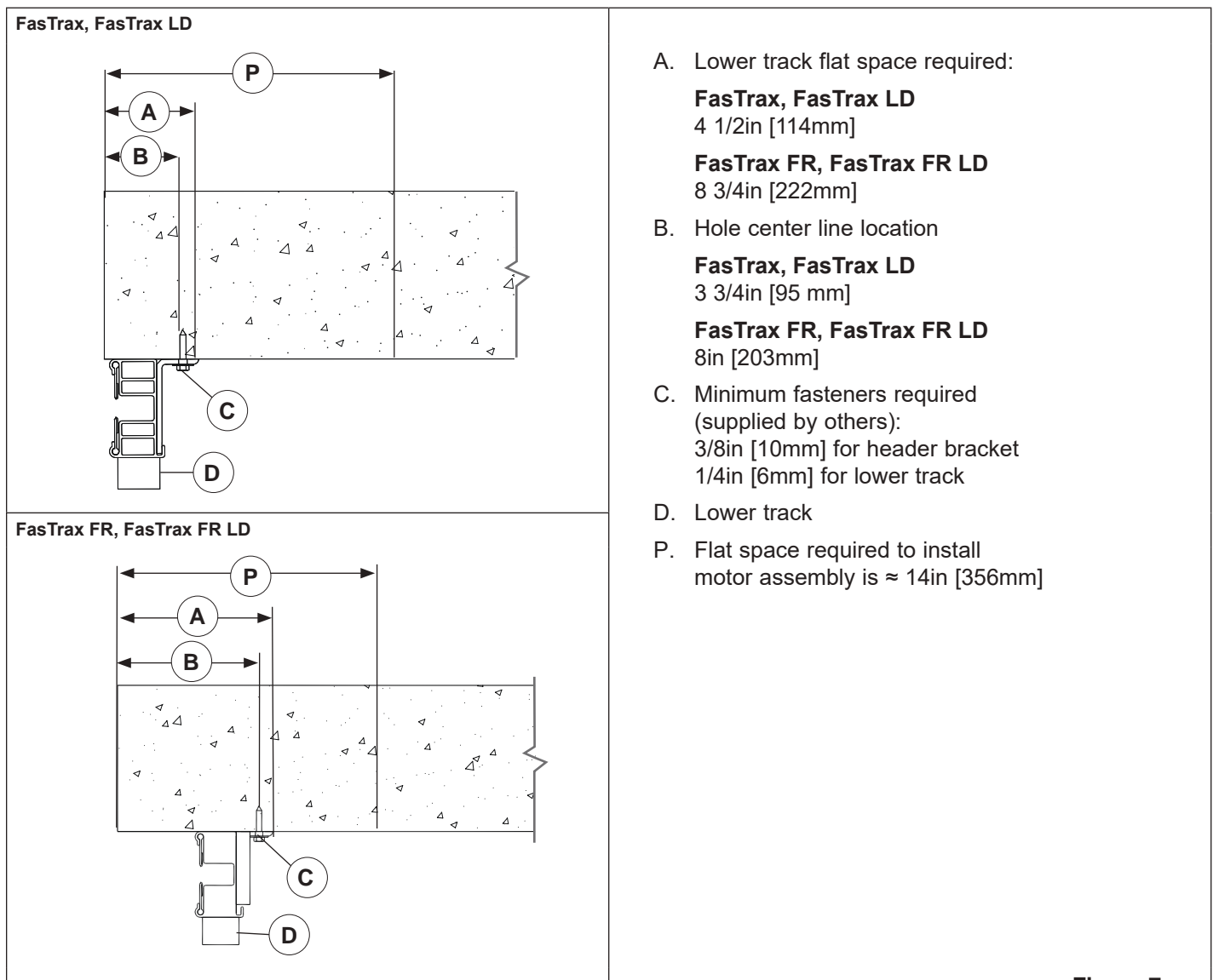

Figure 7

Through bolt fastening is required if the mortar joint will not support the members. Bore a hole through the wall. Use a 3/8in [M10] diameter threaded rod with a washer, nut, and jam nut on each end. It may be necessary to install a backer plate (steel or wood) when the wall will not support the bolt.

INSTALLATION

Mounting Methods *Continued*

Concrete Block or Brick Wall

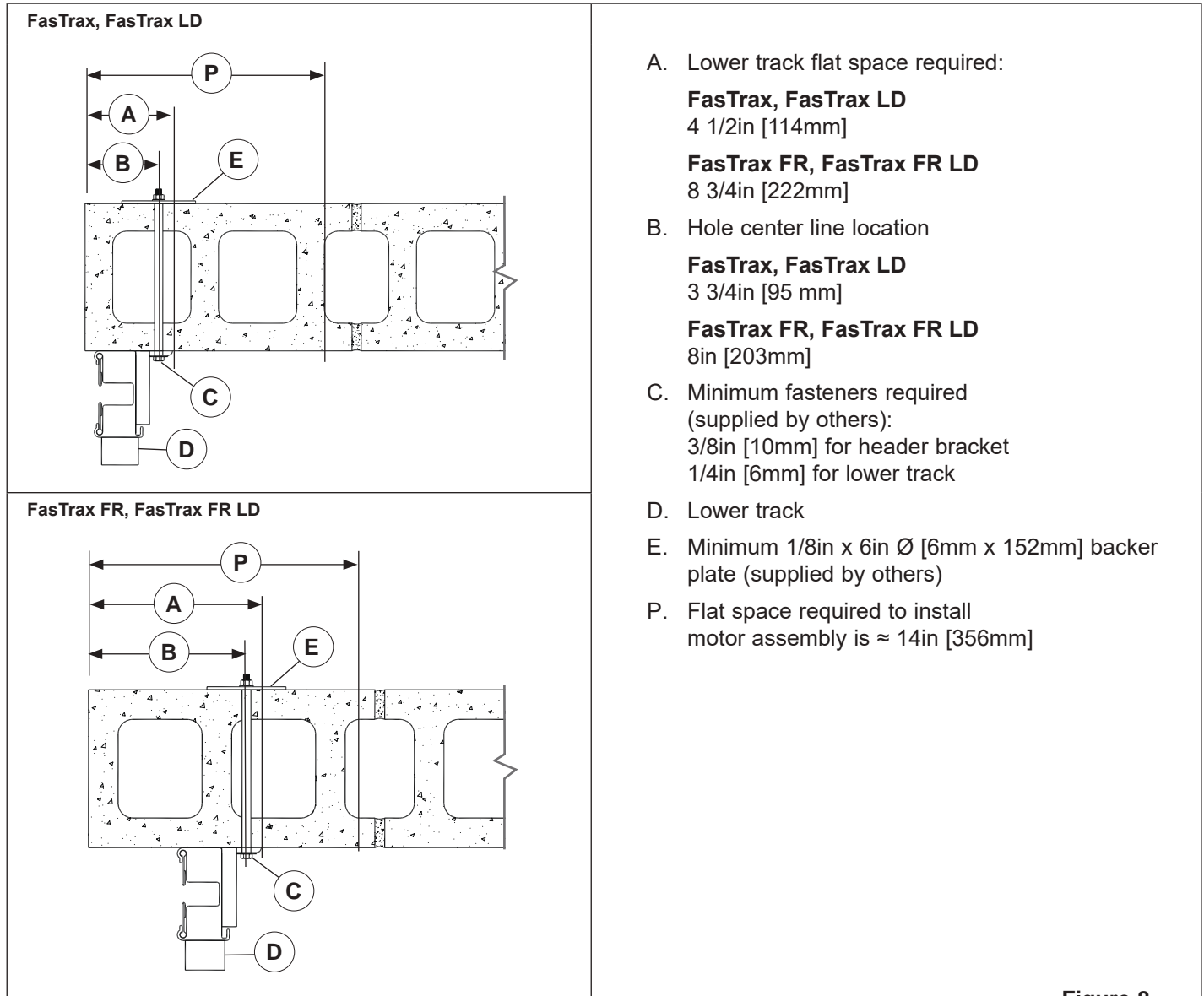

Figure 8

Through bolt fastening is required if the mortar joint will not support the members. Bore a hole through the wall. Use a 3/8in [M10] diameter threaded rod with a washer, nut, and jam nut on each end. It may be necessary to install a backer plate (steel or wood) when the wall will not support the bolt.

INSTALLATION

Mounting Methods *Continued*

Drywall

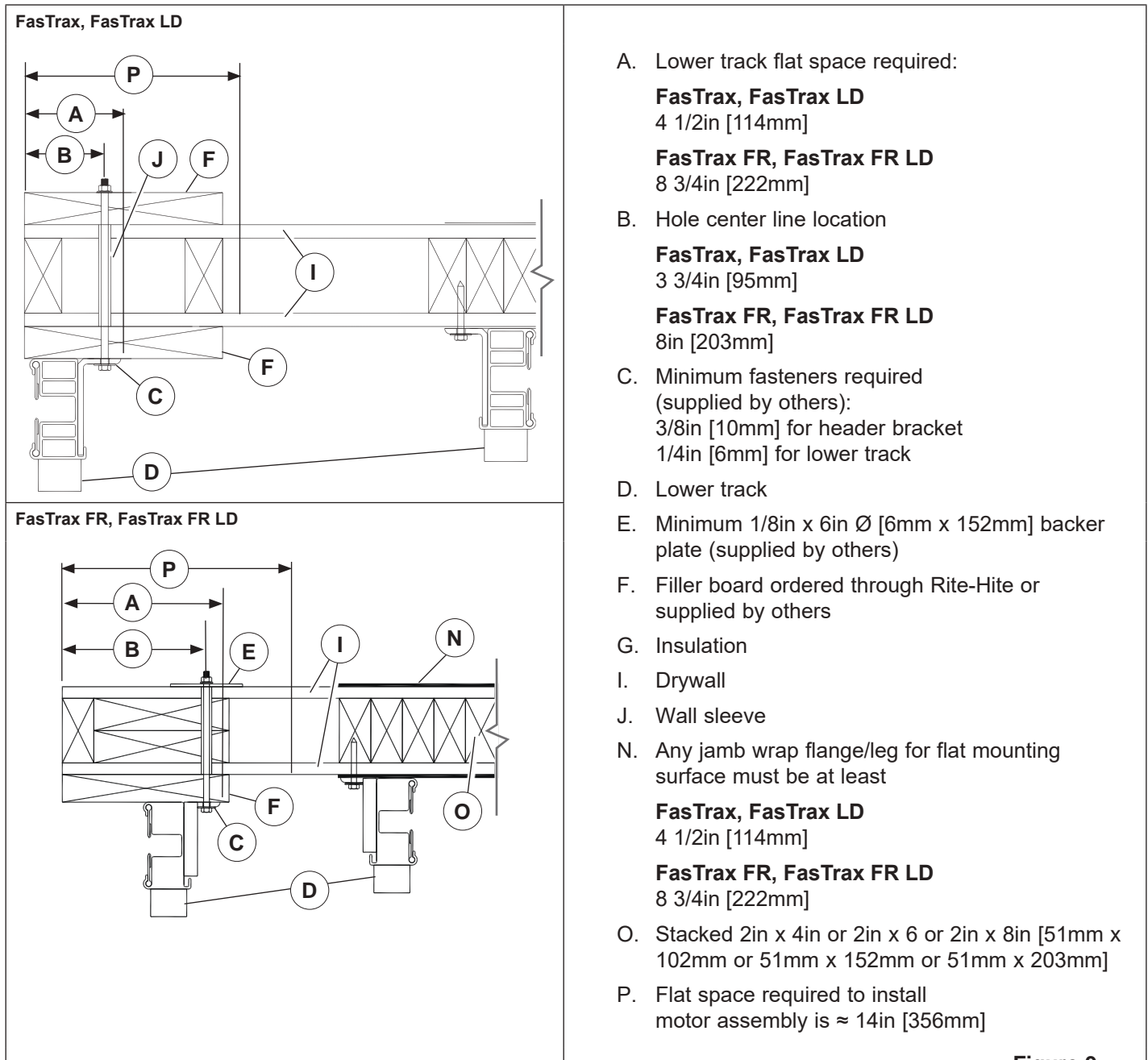

Figure 9

Walls constructed with steel studs, must be a minimum of 20 [1mm] gauge for proper support. If less than 20 [1mm] gauge, further support is required.

INSTALLATION

Mounting Methods *Continued*

Insulated Panel Wall

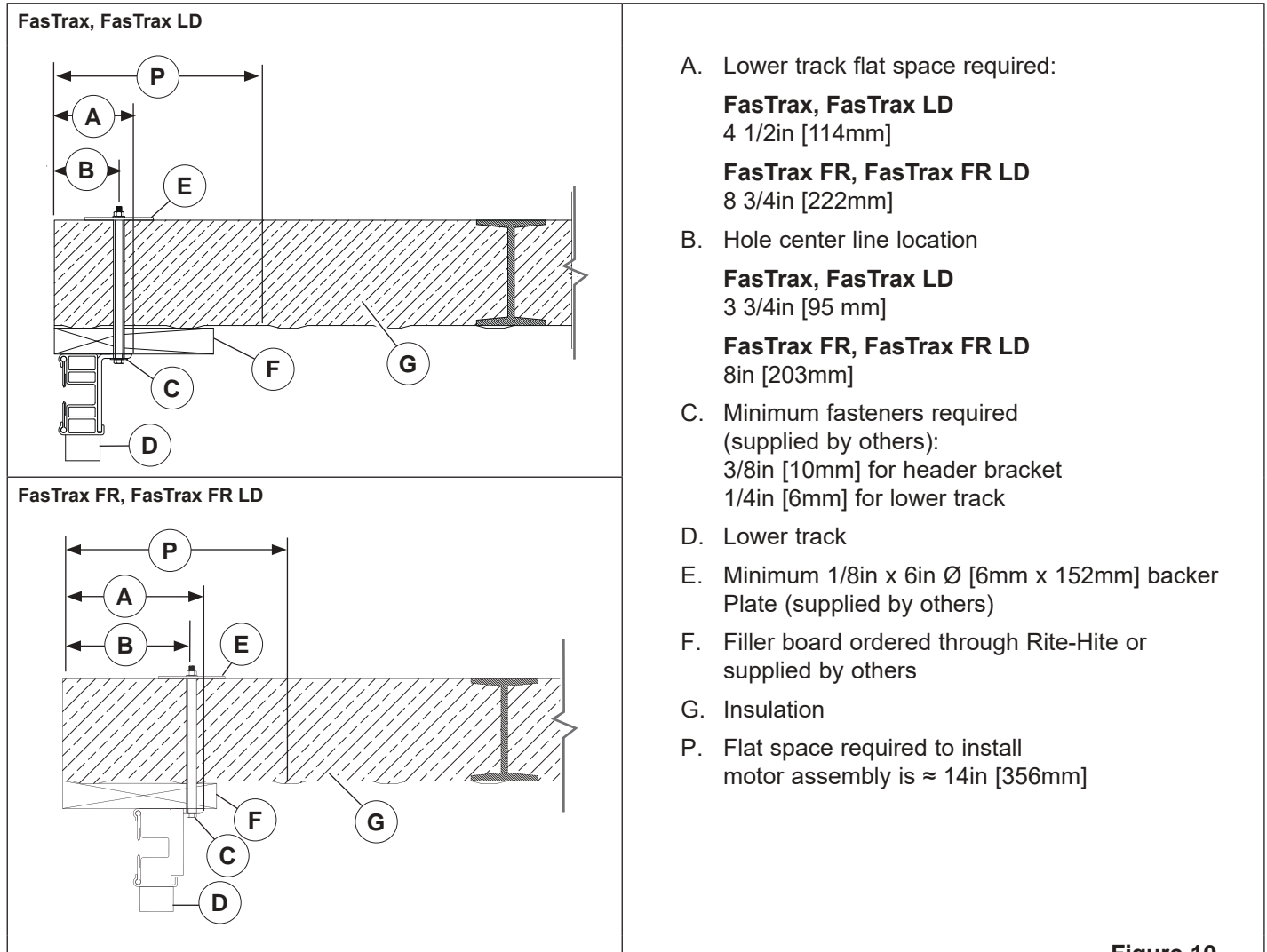

Figure 10

INSTALLATION

Mounting Methods *Continued*

Ribbed Metal Wall

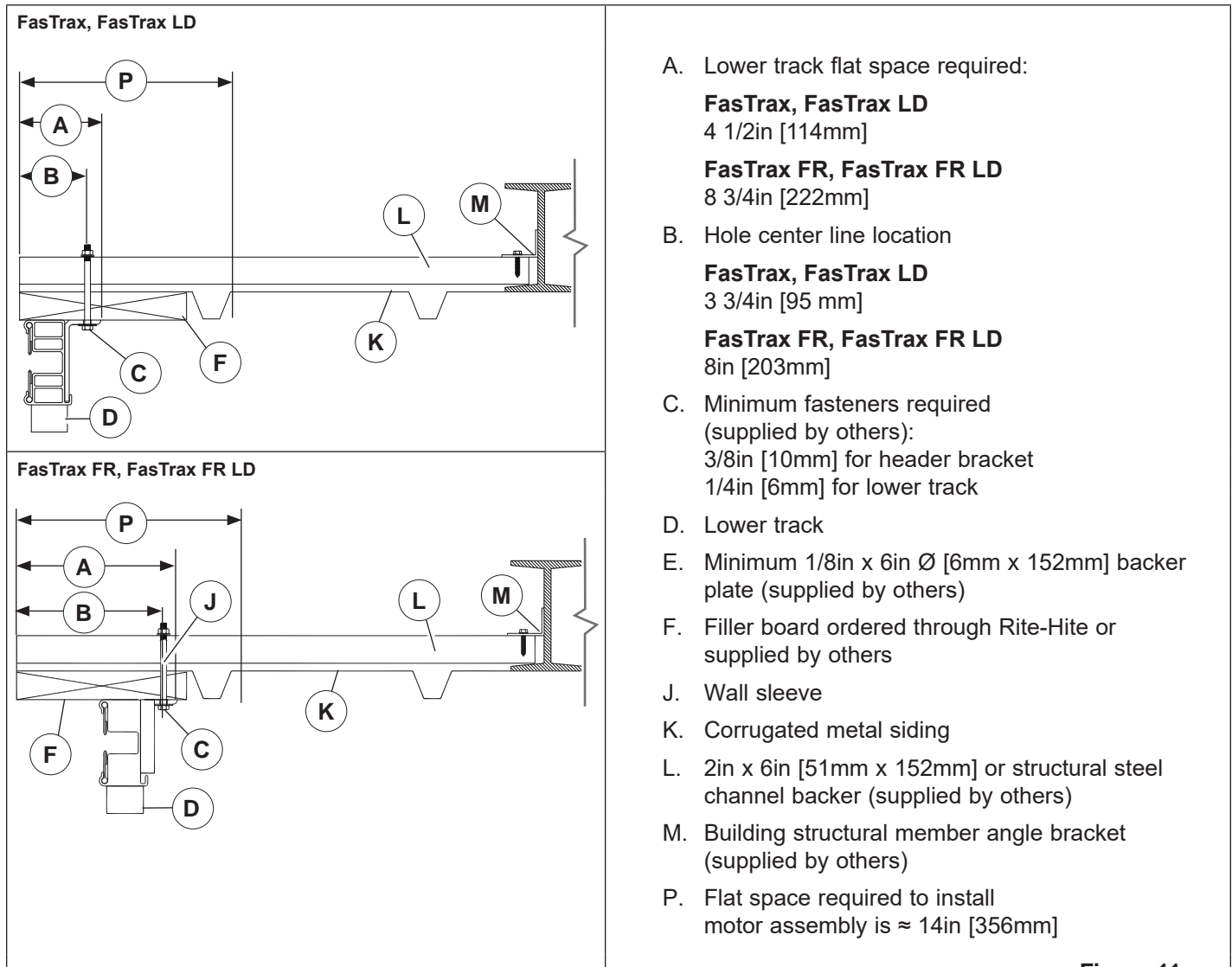

Figure 11

Walls with ribbed metal wall construction must have structural steel added to the face of the jamb and must be structurally sound for lower track installation.

INSTALLATION

Mounting Methods *Continued*

Steel Member

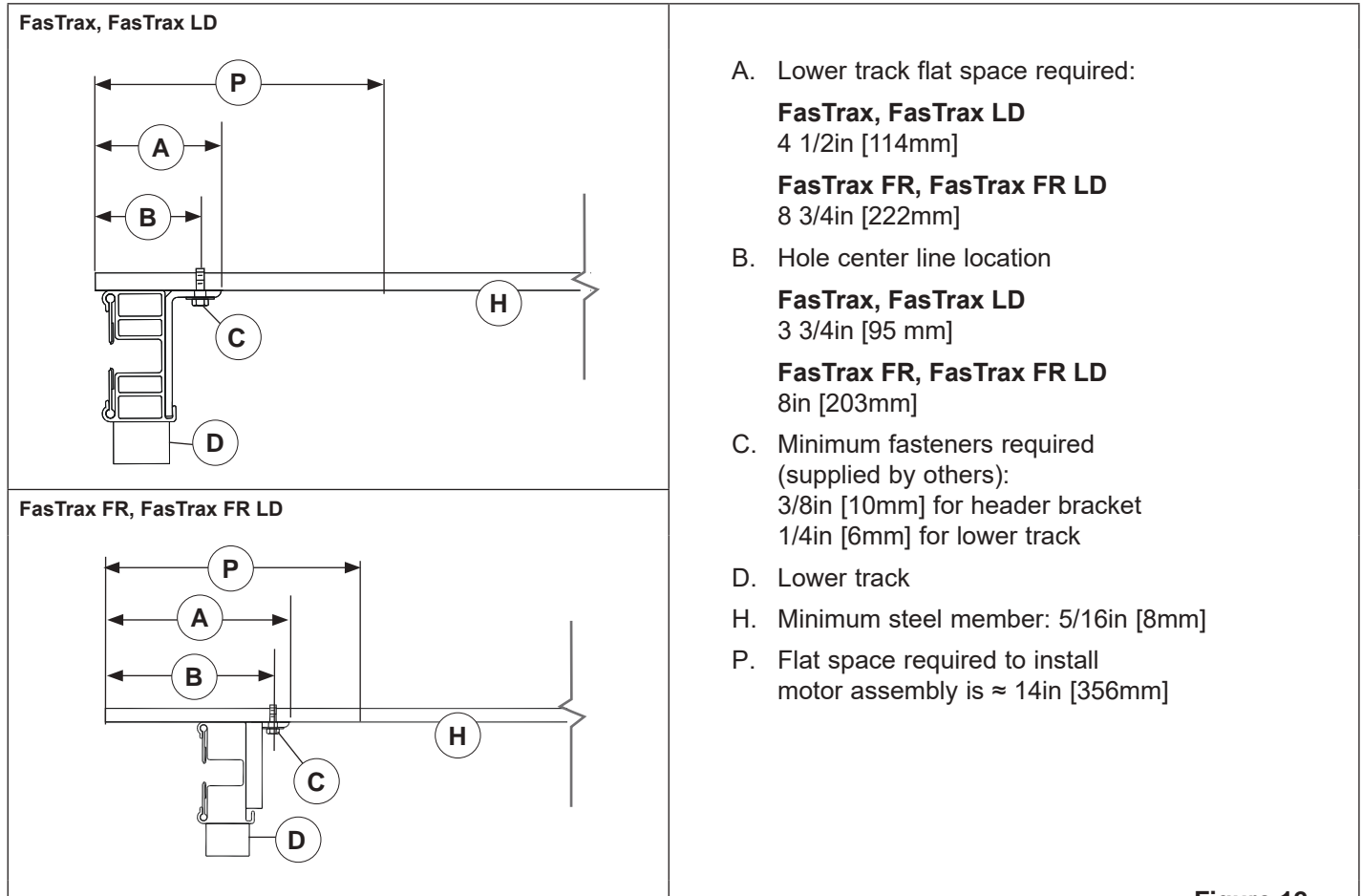

Figure 12

INSTALLATION

Lower Track

NOTICE

If door is equipped with these options:

Weld Plate – proceed to [page 63](#)

Poly Lumber – proceed to [page 60](#)

The lower tracks require mounting at the proper width.

Too wide:

Excess wear is placed on the drive spheres

Too narrow:

The curtain may appear wavy or crease in the center

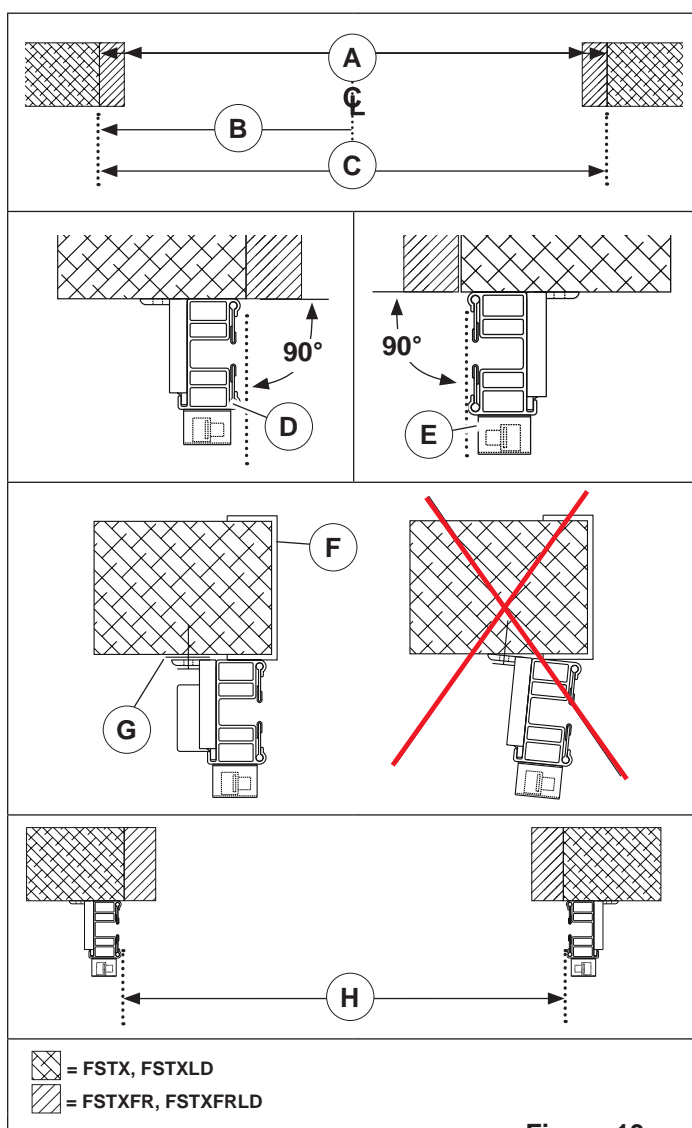

Figure 13

NOTE: If it is critical to maintain environmental separation preventing the transfer of cold and warm air, caulk the lower track. This can be done at the inside or outside edge or between the wall and the back of the lower track, wherever it is best suited.

Measure Door Opening Width (A), find center and place mark on the floor.

1. Measure from the centerline and place a mark on the floor at:

FasTrax, FasTrax LD

(B) 1/2 O.D.W. + 1/4in [6mm]

FasTrax FR, FasTrax FR LD

(B) 1/2 O.D.W. + 4 1/2in [114mm] (+ 1/16in [1.5mm], -0)

2. From the previously made mark, measure over:

FasTrax, FasTrax LD

(C) O.D.W. + 1/2in [13mm] (+ 1/8in [3mm], -0)

FasTrax FR, FasTrax FR LD

(C) O.D.W. + 9in [229mm] (+ 1/8in [3mm], -0) and place a mark on the floor.

3. Place non-drive side lower track at the previously made mark on the floor.
4. Lower track must be 90° to wall. Measure the angle from the front edge of the lower track (D). Use shims as required to square the track. If possible, clamp the track in place.
5. Using a 6ft [2m] level, make sure that the track is plumb in both directions.
6. Place drive side lower track (E) at the previously made mark on the floor.
7. Lower track must be 90° to wall. Measure the angle from the front edge of the lower track (E). Use shims as required to square the track. If possible, clamp the track in place.
8. Repeat steps 5 and 6.
9. **If the wall has a jamb cap (F), the lower track MUST be shimmed out (G).**
10. **Verify Critical Dimension (H):** Take this measurement from the front edge of the lower tracks (I).

FasTrax, FasTrax LD

(H) O.D.W. + 1/2in [13mm]

FasTrax FR, FasTrax FR LD

(H) O.D.W. + 9in [229mm] (+ 1/8in [3mm], -0)

INSTALLATION

Lower Track *continued*

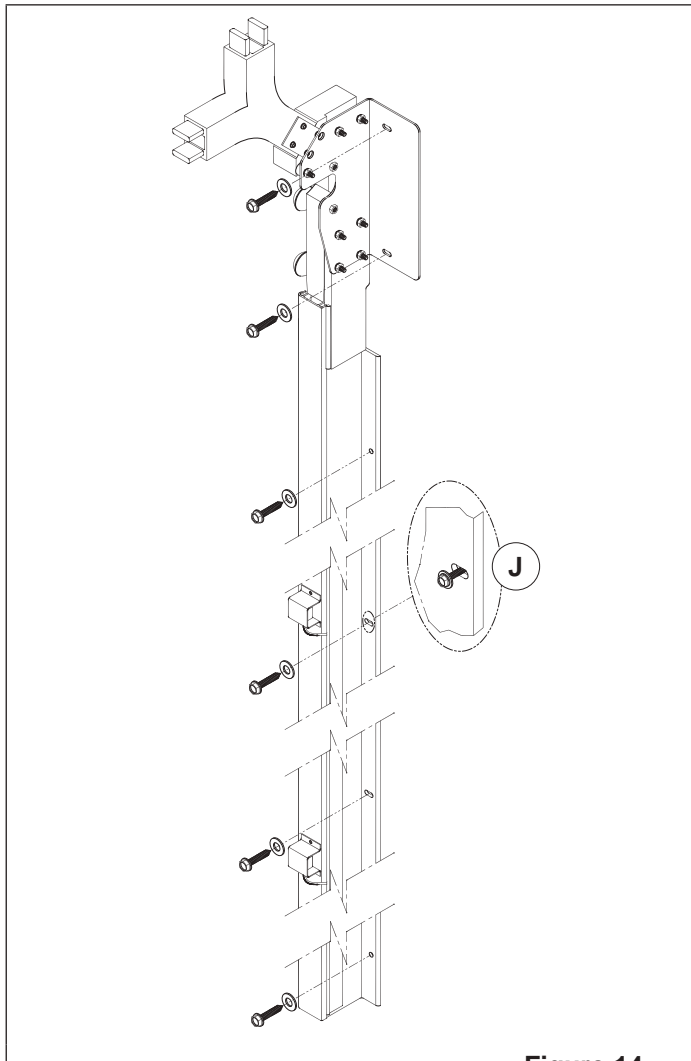

Figure 14

11. Place fasteners in the center of the slot at the top, middle, bottom and tighten. Slot location will vary based on ordered height.
12. If the hole goes completely through the wall, use through bolts and backer plates (K). Refer to **"Acceptable Fasteners"** on page 11 and **"Typical Fastener Spacing"** on page 11 for further details.
13. After the door is installed and operational make sure the curtain is not too tight or loose. Place fasteners in the remaining holes.

NOTE: All holes must be utilized to prevent lower track movement.

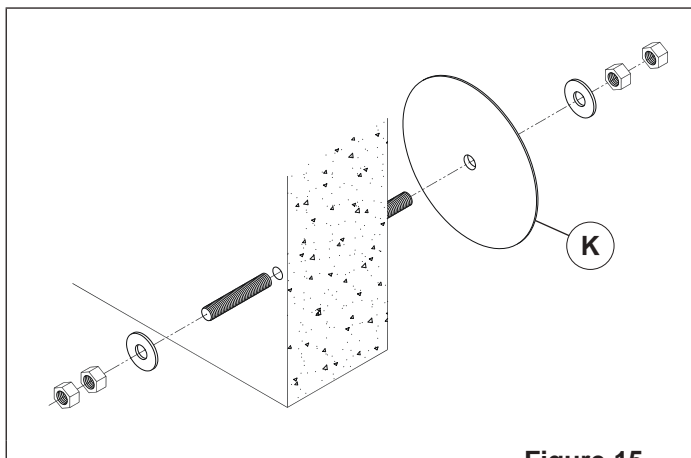

Figure 15

INSTALLATION

Perimeter Seal (FasTrax FR, FasTrax FR LD)

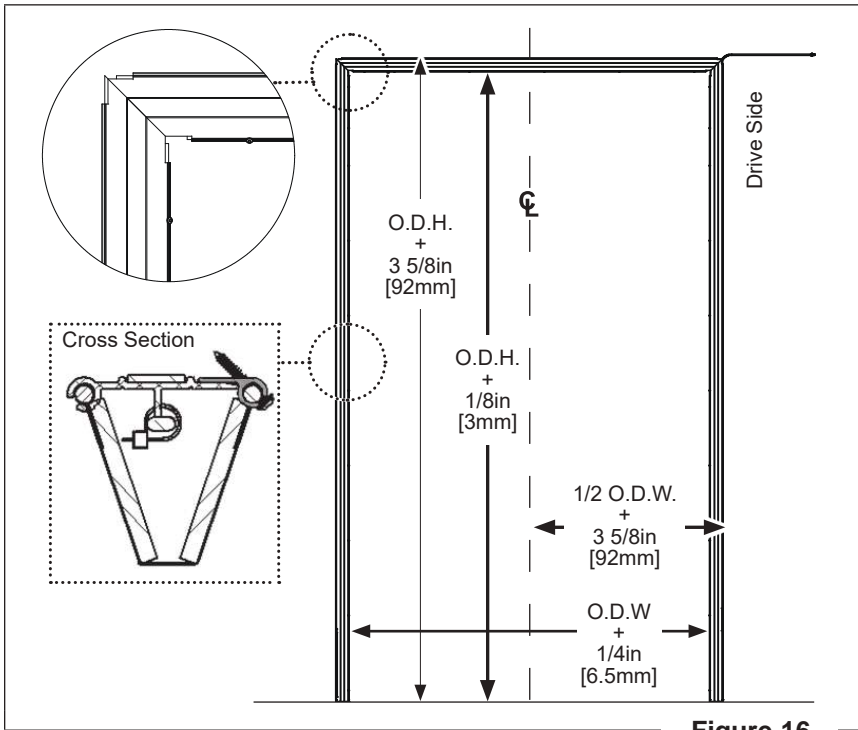

Figure 16

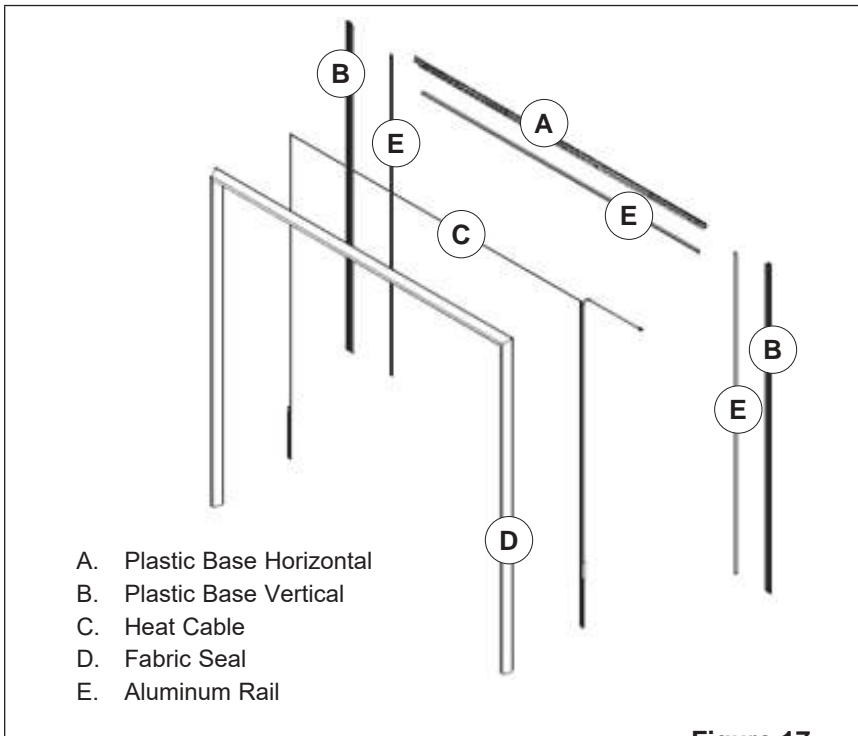

Figure 17

INSTALLATION

Perimeter Seal *Continued*

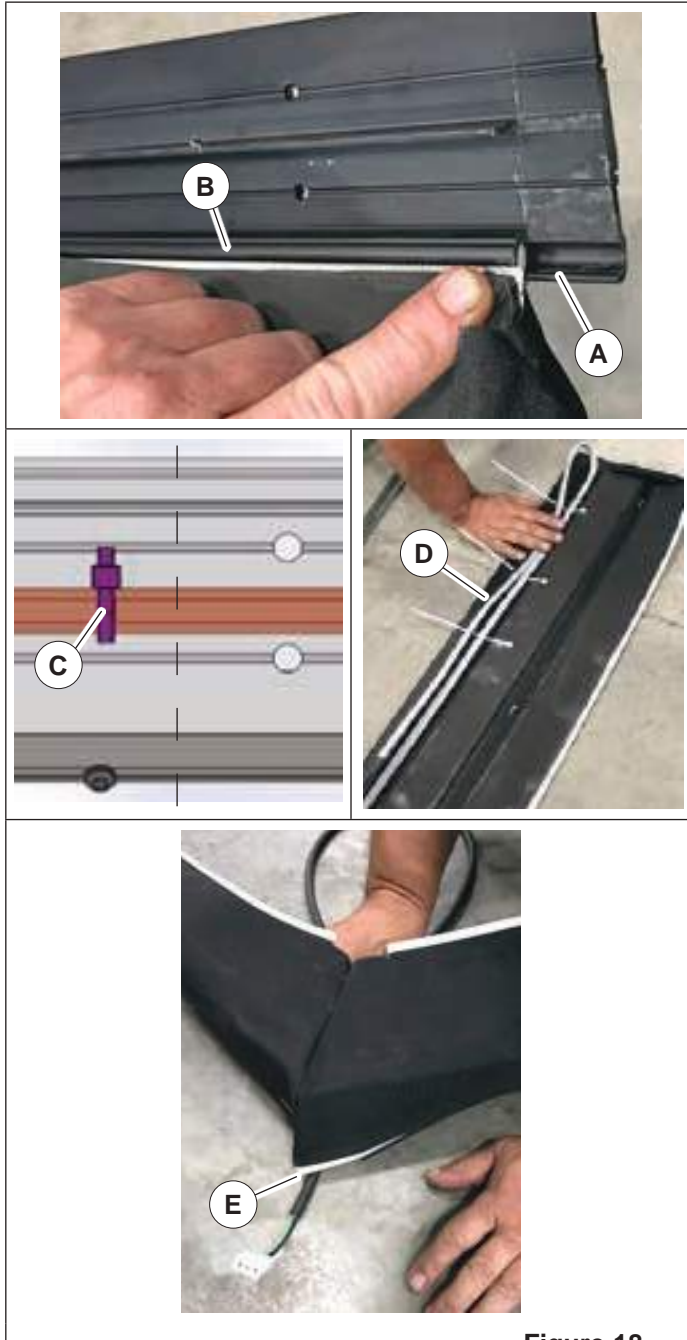

Figure 18

1. Assemble the perimeter seal on the floor.
2. Slide fabric perimeter seal into the plastic bases. Horizontal first, then vertical. Align the bottom of the fabric cord with the end of the vertical base before cutoff (A). Hold the cord in place with screws 3in [76mm] in from both ends of each base (6 total) (B).
3. Locate center mark of heat cable and align with center mark of horizontal base.

NOTE: Plug end of cable must be on drive side. Attach heat cable to horizontal base using wire ties (C) and holes on center of base.
4. Attach heat cable to vertical bases with wire ties. Heat cable (D) doubles back \approx 1.5ft [450mm] at bottom. Drive side doubles back to upper corner.
5. Route the cable with plug out the motor side corner of the seal (E).

INSTALLATION

Perimeter Seal *Continued*

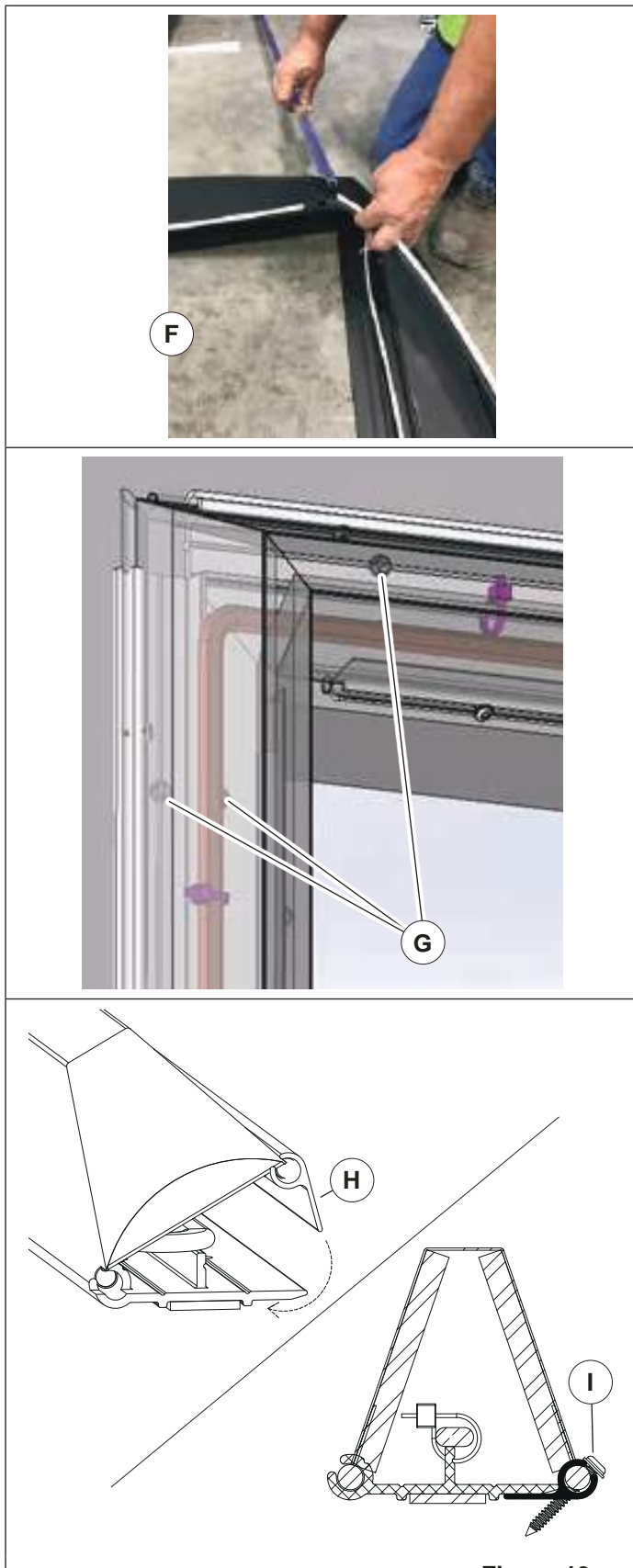

Figure 19

6. (F) Slide aluminum rails onto the inner cords of both the horizontal and 2 vertical legs of the fabric seal. **DO NOT** attach the rails at this point.
7. Position assembled seal against the wall.
 - Align the center of the horizontal seal with the center line of the opening.
 - Bottom of horizontal base should be O.D.H. + 5/8in [16mm] from the floor.
 Fasten the base at the center to hold in place.
8. Position vertical pieces against the wall.
 - Miters at corners must align, and the base should extend to and make contact with the floor.
 - The total distance between the 2 vertical plastic bases should be O.D.W. plus 1 1/4in [32mm].
 When aligned, use fasteners (supplied) to attach all 3 bases to the wall, using each mounting hole located 20in [500mm] apart (G).
9. Center aluminum rail on cords and tuck the leg of the aluminum rail (H) in the gap behind the base. Pre-drill and fasten using the screws (supplied) (I) every 30in [750mm].

INSTALLATION

Upper Track

Radial (FasTrax, FasTrax LD)

NOTE: FasTrax LD shown, FasTrax similar

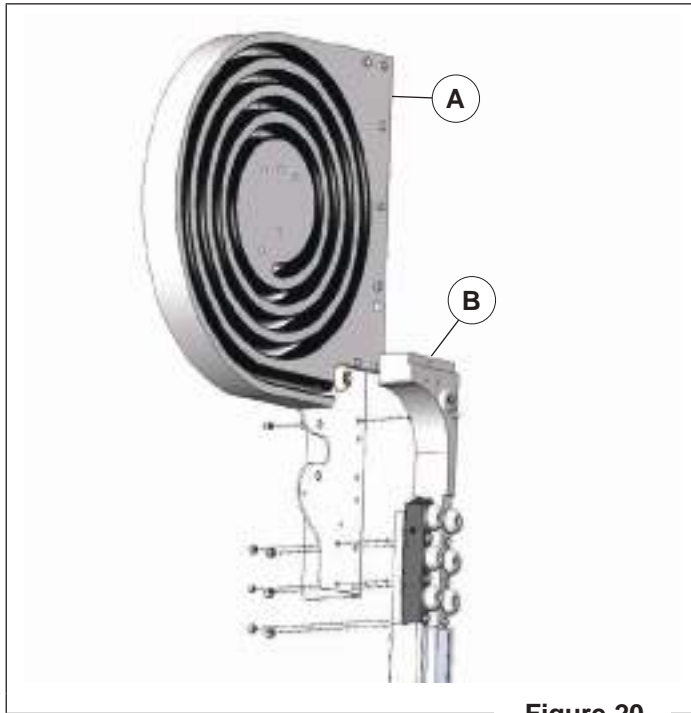

Figure 20

Assemble radial (A) to the lower track (B) using the 8 bolts and nuts provided.

1. Verify area (C) behind wall mounting plates is solid.
2. Measurement (D) must be O.D.W. + 1/4in [6mm] ± 1/8in [3mm]. Make sure radials are parallel to each other and square to the wall.
3. Attach spreader bar (E) bracket to radial with (4) 3/8-16 x 4in [M10 x 102mm] bolts, flat washers and lock nuts.
4. Route non-drive photoeye cables through holes (F) in non-drive and drive radials. Use cable clamps provided to fasten to the wall.
5. Rear roller (G) on radial is factory installed and must be in place to make sure a smooth curtain transition.

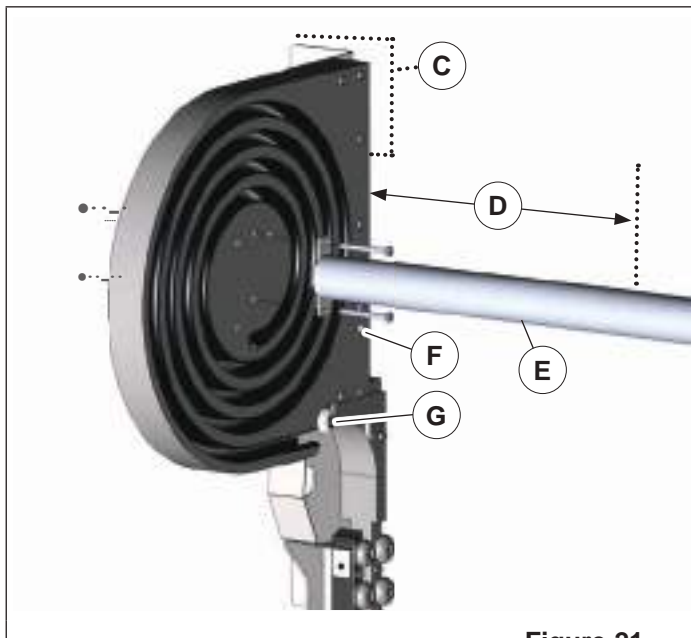

Figure 21

INSTALLATION

Upper Track *Continued*

Wrapback

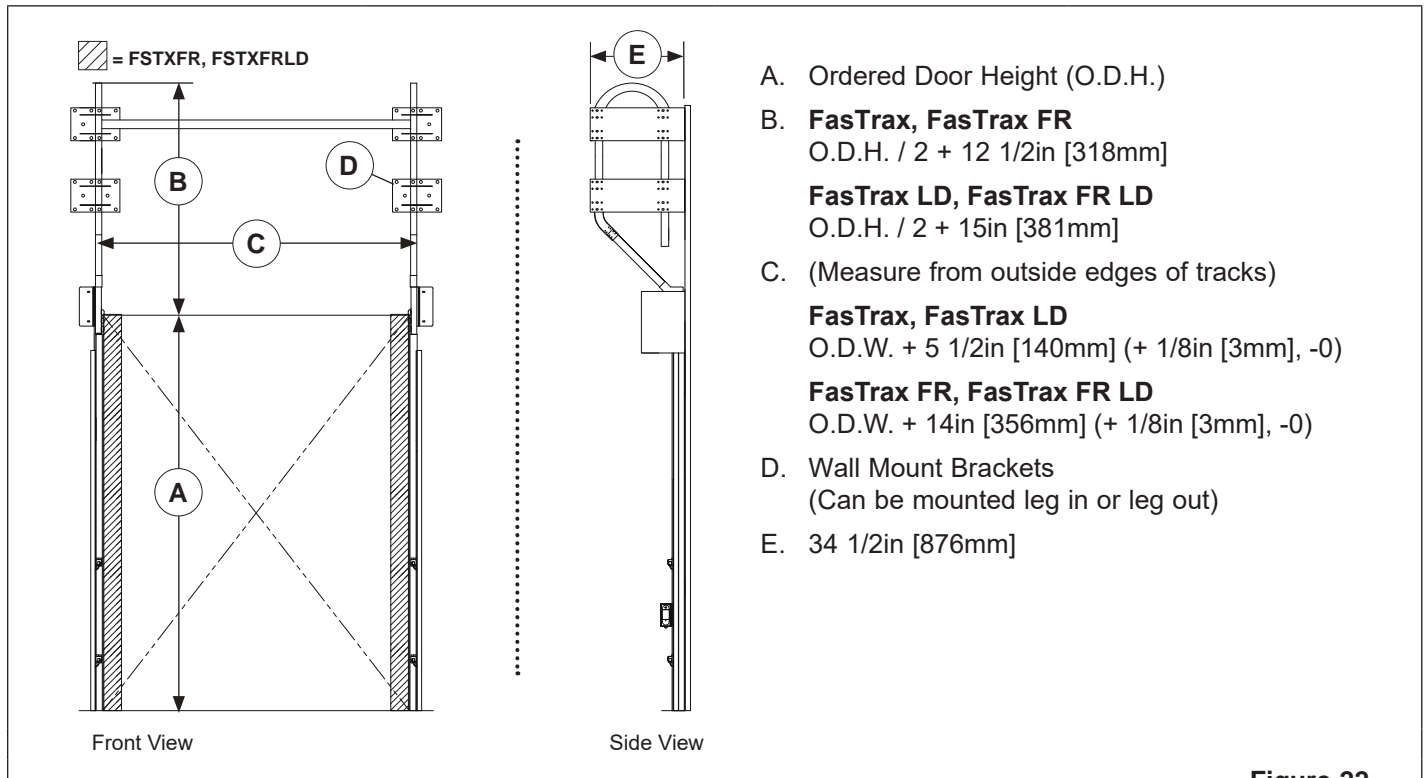

Figure 22

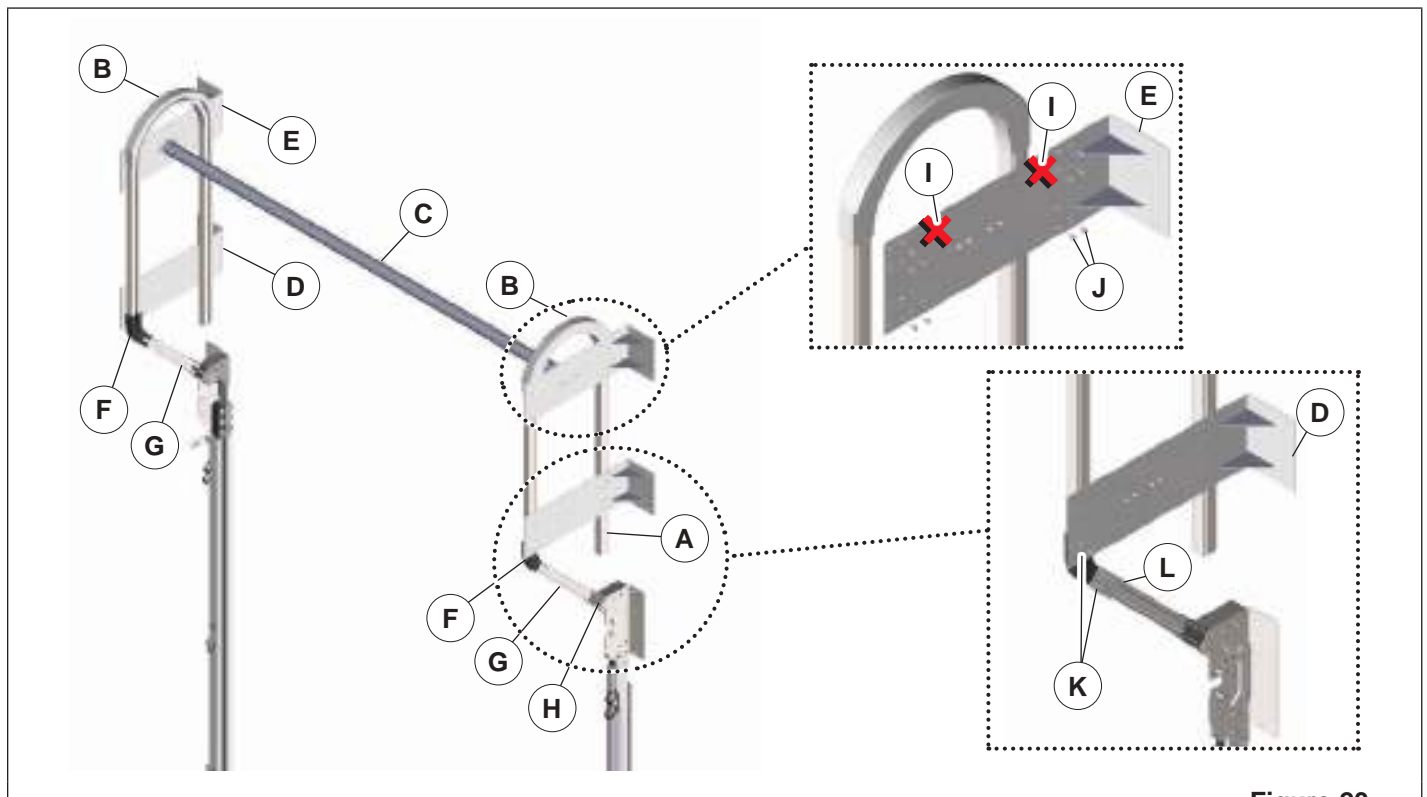

Figure 23

INSTALLATION

Upper Track *Continued*

Wrapback *Continued*

NOTICE

Hold drill perpendicular and level to make sure screws go into the outer cavities of the upper track. **DO NOT** drill into curtain groove.

Use fasteners that will support the entire door weight.

1. The proper radius (H) is already assembled to the lower track.
2. Locate the 2 pieces of upper track (G) (26 3/4in [680mm] or 23in [584mm] for large driver). Slide end of upper track: FasTrax/FasTrax FR: 26 3/4in [680mm] FasTrax LD/FasTrax FR LD: 23in [584mm] into the lower track splice connector. Pilot holes (.201Ø x 1 1/4in [5mm x 32mm] deep) (K) MUST be pre-drilled into lower track radius. Install 4 lag screws per location.
3. Locate the 2 45° radius pieces (F) and slide onto the first piece of upper track. Locate the 2 middle length pieces of upper track and slide into the 45° radius. Use self drill/tap screws (L) in aluminum track. Fasten 4 places in each location.
4. Plumb track in both directions and fasten to wall mount bracket (E) using self drill/tap screws (J). Attach 180° radius (B) to the upper track and fasten to the wall mount bracket. See dimension (B) of "**Figure 22**" on page 24 for top of 180° radius.
5. Locate the 2 longest remaining pieces of upper track (D.O.H. / 2) - 26in [660mm]. Slide end of upper track (A) into the 180° radius, level, plumb and fasten to wall mount bracket using self drill/tap screws.
6. Place mounting bracket (D) in position against the radius and upper track and fasten using self drill/tap screws.
7. Attach spreader bar (C) between wrap back brackets.

INSTALLATION

Upper Track *Continued*

Vertical

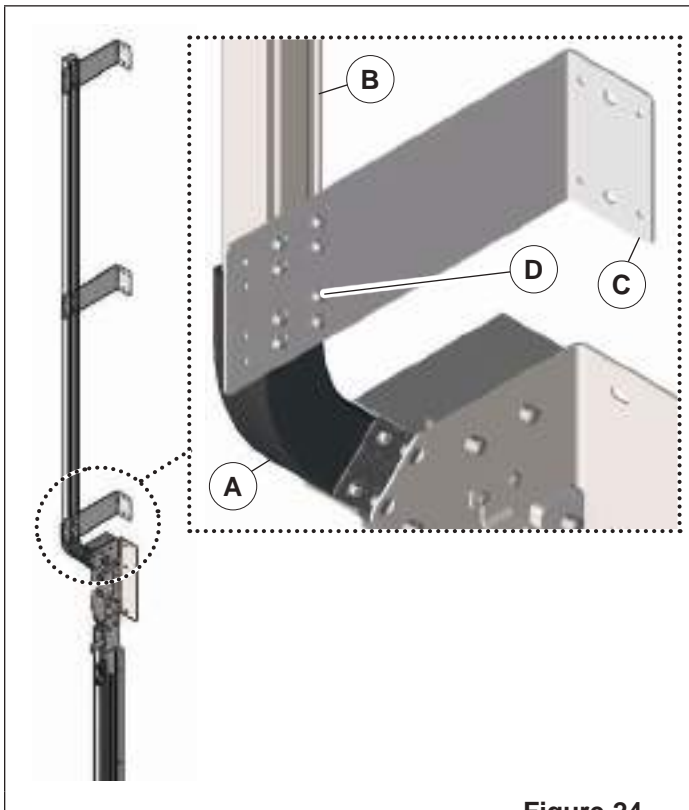

Figure 24

1. The proper radius (A) is already assembled to the lower track.
2. Locate the 2 pieces of upper track (B) and the supplied wall mount brackets. Slide end of upper track into the lower track radius (A), level, plumb and fasten to wall mount bracket using self drill/tap screws.
3. Place mounting bracket (C) in position and mark holes to be drilled in wall.
4. Pilot holes (.201Ø x 1 1/4in [5 x 32mm] deep) **MUST** be pre-drilled into lower track radius (D).
5. Measure from outside edges of tracks (E):
FasTrax, FasTrax LD
 O.D.W. + 5 1/2in [140mm] (+ 1/8in [3mm], -0)
FasTrax FR, FasTrax FR LD
 O.D.W. + 14in [356mm] (+ 1/8in [3mm], -0)
6. **CRITICAL:** Fasten bracing (F) at the end of the track, maintaining proper spacing.
7. Fasten bracing (G) to diagonal provide support from track to ceiling or wall.
8. Fasten mounting brackets (H) to the wall and then the upper track.

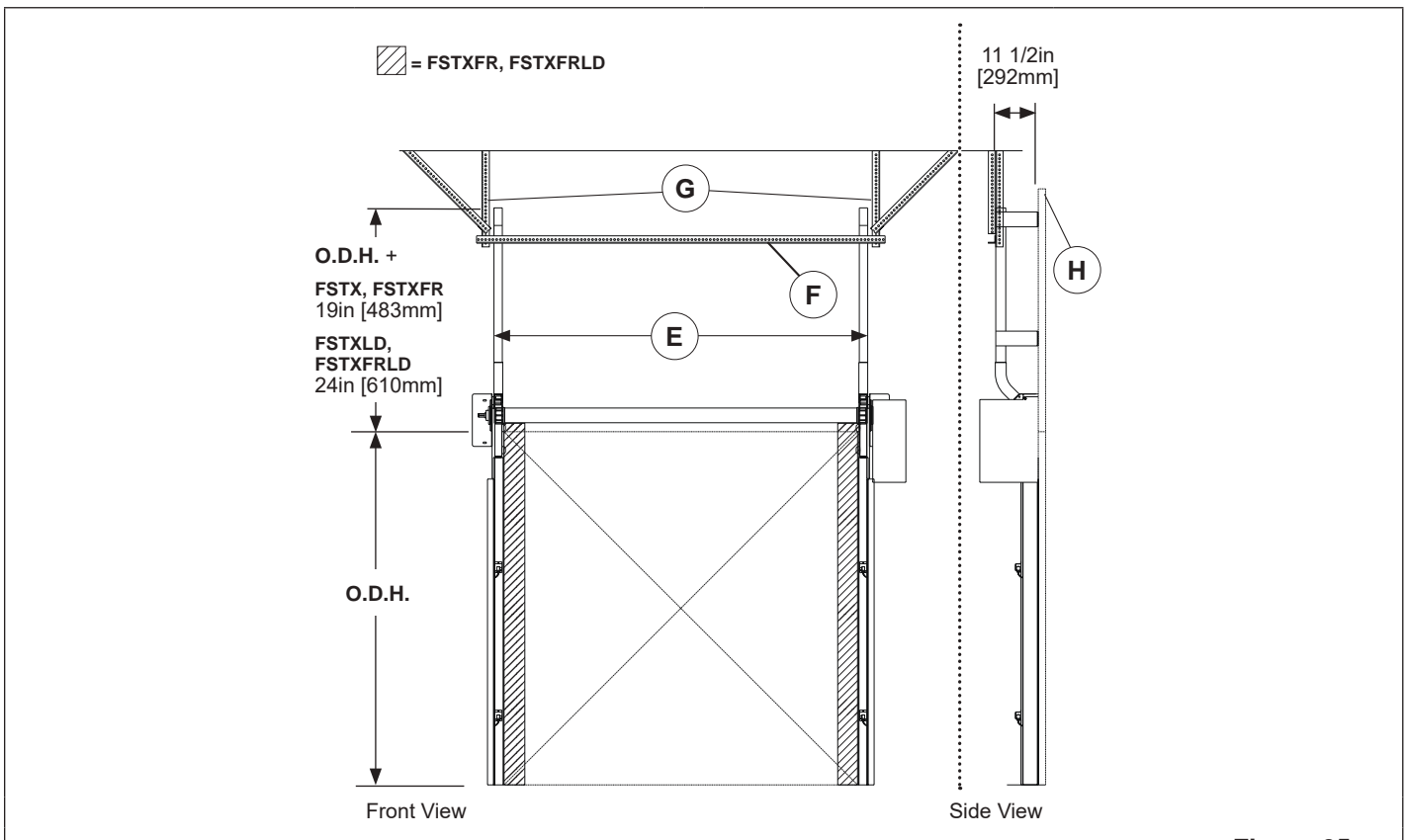

Figure 25

INSTALLATION

Upper Track *Continued*

High Lift

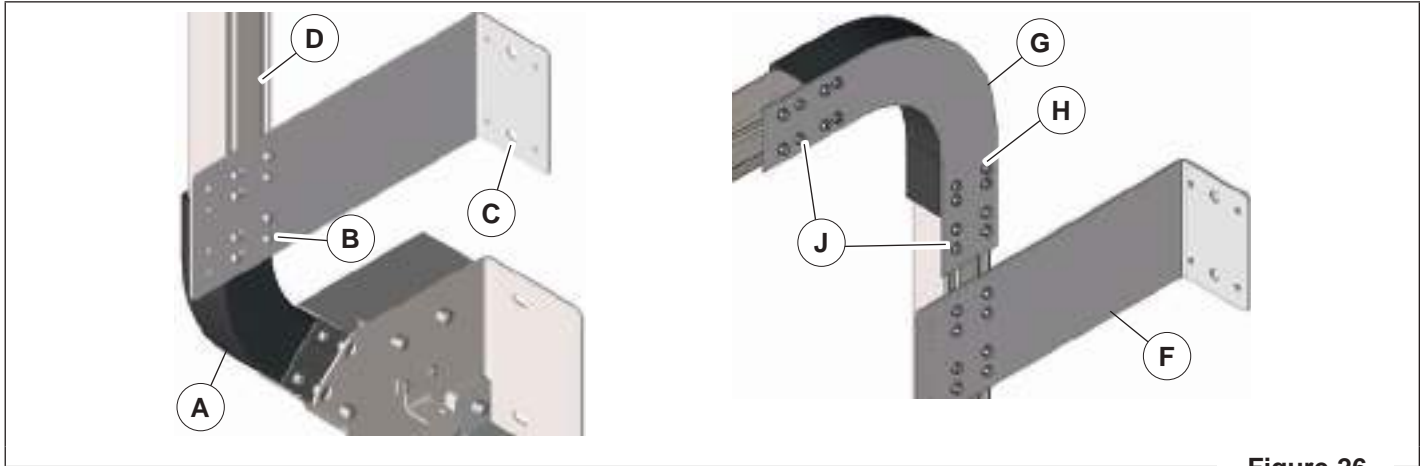

Figure 26

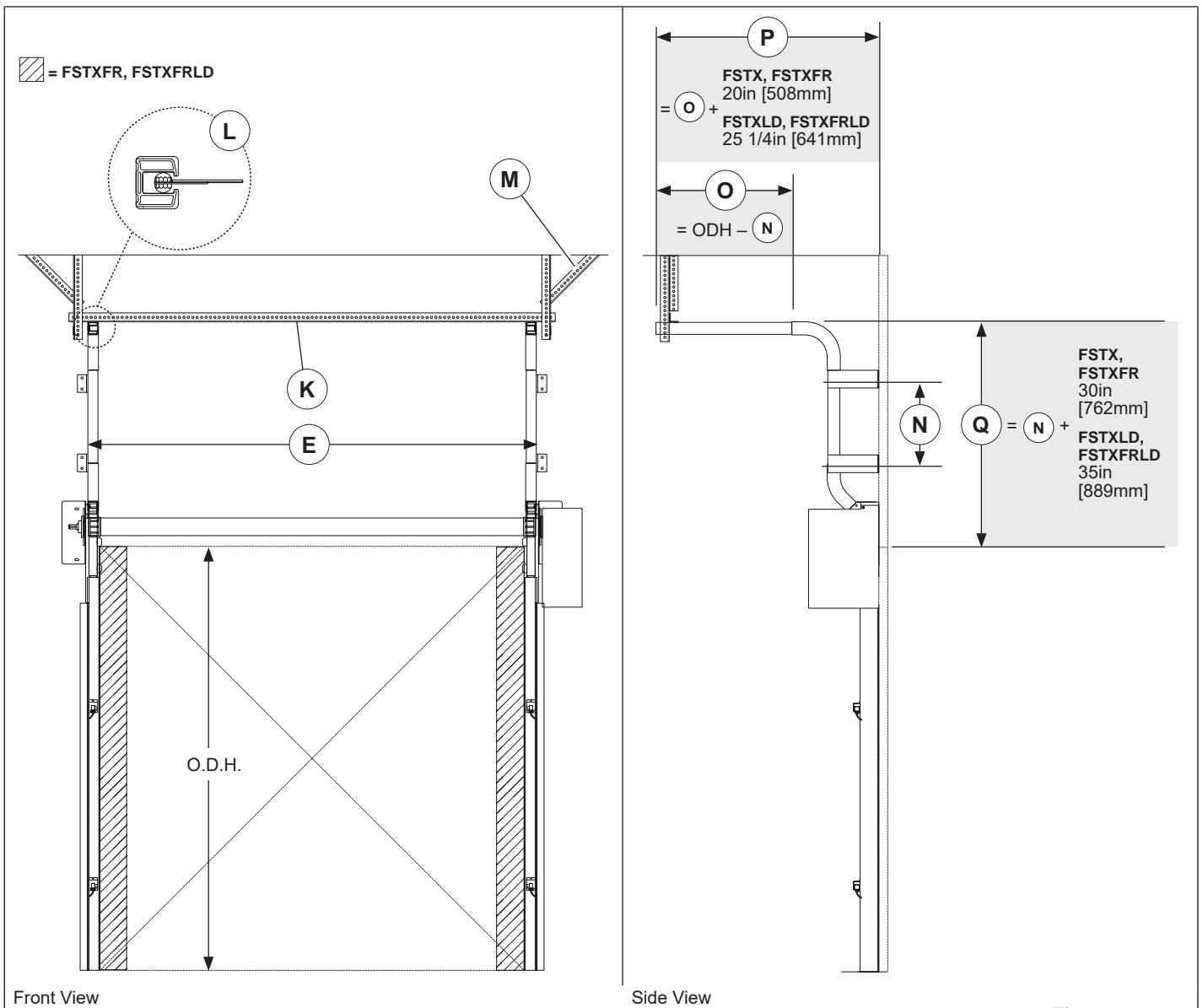

Figure 27

INSTALLATION

Upper Track *Continued*

High Lift *Continued*

NOTE: For high lift, determine the high lift required per sales order and cut vertical tracks to length. **ONLY 1 CUT PER TRACK-DO NOT CUT SAME TRACK TWICE.**

NOTICE

Hold drill perpendicular and level to make sure screws go into the outer cavities of the upper track. **DO NOT** drill into curtain groove.

Use fasteners that will support the entire door weight.

NOTE: If (N) is unknown, then Rite-Hite advises dimension to be a maximum of 1/2 O.D.H. (Figure 27).

1. The proper radius (A) is already assembled to the lower track (Figure 26).
2. Pilot holes (B) (.201Ø x 1 1/4in [5 x 32mm] deep) MUST be pre-drilled into lower track radius.
3. Place mounting bracket (C) in position and mark holes to be drilled in wall.
4. Locate the 2 pieces of upper track (D) and the supplied wall mount brackets. Slide end of upper track into the lower track radius (A), level, plumb and fasten to wall mount bracket using self drill/tap screws.
5. Use self drill/tap screws (J) in horizontal and vertical track.
6. Fasten upper wall mount bracket (F) to track and wall, below radius and splice bracket (G). Minimum 6in x 6in [152mm x 152mm] backer plate required on hollow or insulated walls.
7. Use track splice bracket (G) to join lower and upper track. Drill .201 [5mm] Ø pilot hole 1 1/4in [32mm] deep for lag screws.
8. Use lag screws (H) in radius bracket.
9. Measure from outside edges of tracks (E):

FasTrax, FasTrax LD
O.D.W. + 5 1/2in [140mm] (+ 1/8in [3mm], -0)

FasTrax FR, FasTrax FR LD
O.D.W. + 14in [356mm] (+ 1/8in [3mm], -0)
10. **CRITICAL:** Fasten punched angle (K) (Figure 27) bracing at the end of the track, maintaining proper spacing.
11. When curtain is raised later in installation, make sure spheres are centered in track groove (L), if too tight, move tracks in, if too loose spread tracks apart.
12. Fasten bracing to diagonal (M) provide support from track to ceiling or wall.

INSTALLATION

Upper Track *Continued*

Standard Lift

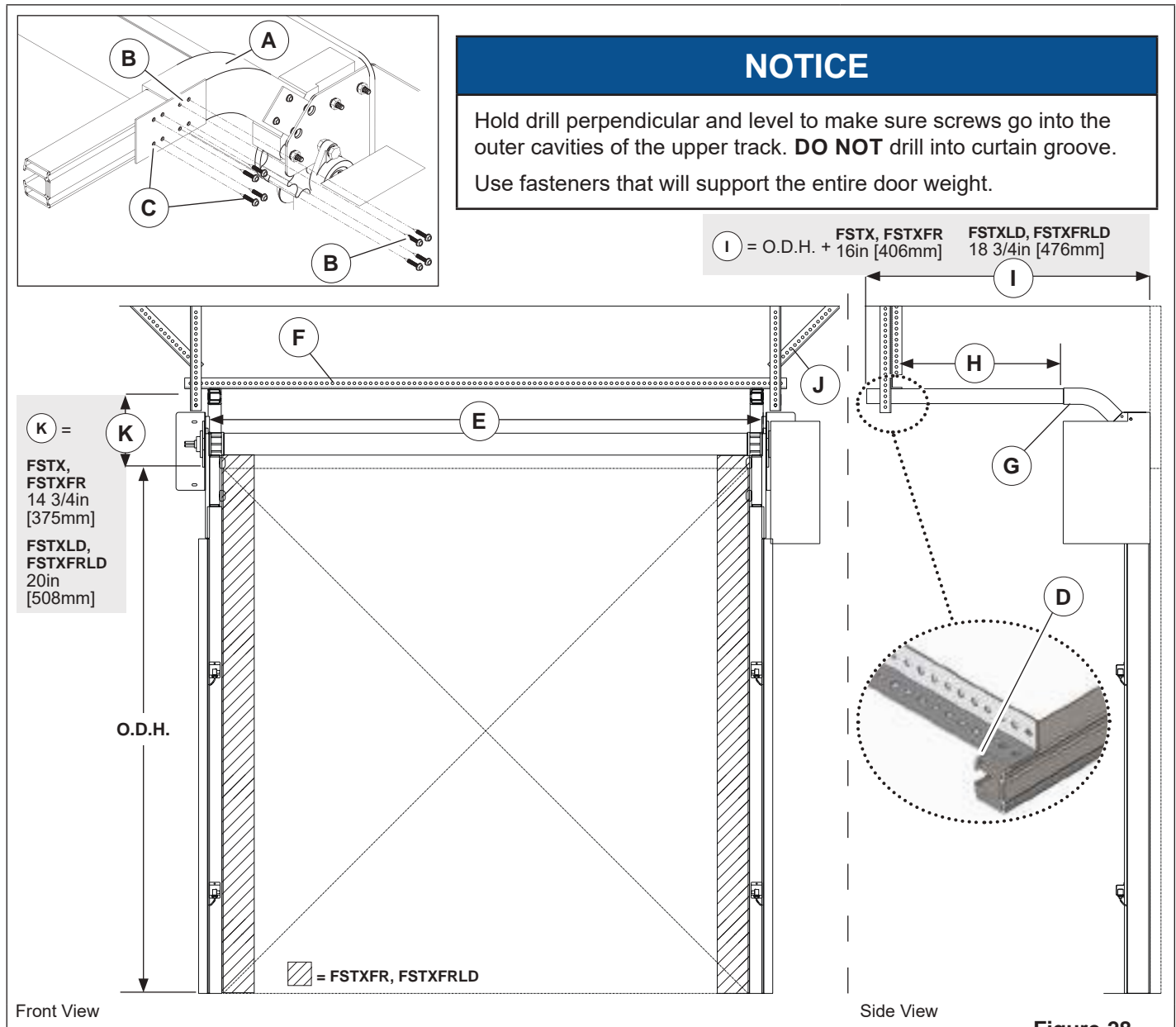

1. The proper radius (A) is already assembled to the lower track. **DO NOT** use self drill/tap screws here (B). Locate splice bracket and fasten between the upper and lower track. Pilot holes (.201Ø x 1 1/4in [5mm x 32mm] deep) **MUST** be pre-drilled into lower track radius (A). Install 4 lag screws per location.
2. Use self drill/tap screws in the horizontal track (C).
3. At the end of the track, place punched angle (F) and drive self drill/tap screw (D) into the curtain groove to prevent curtain top roller from coming out of track.
4. Measure from outside edges of tracks (E):
 - FasTrax, FasTrax LD**
O.D.W. + 5 1/2in [140mm] (+ 1/8in [3mm], -0)
 - FasTrax FR, FasTrax FR LD**
O.D.W. + 14in [356mm] (+ 1/8in [3mm], -0)
5. For standard lift, slide end of upper track into the lower track radius (G), level and hold in place.
6. If > 6ft [1800mm] span, must provide another brace (H).
7. Fasten bracing to diagonal (J) provide support from track to ceiling or wall.

INSTALLATION

Upper Track *Continued*

45° Tilt Lift

NOTICE

Hold drill perpendicular and level to make sure screws go into the outer cavities of the upper track. **DO NOT** drill into curtain groove.

Use fasteners that will support the entire door weight.

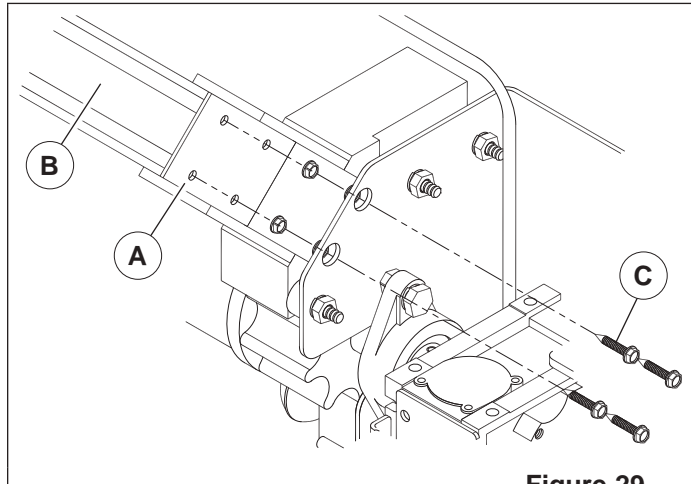

Figure 29

1. Use track splice bracket (A) to join lower and upper (B) track. Drill .201in [5mm] Ø pilot hole 1 1/4in [32mm] deep for lag screws in radius. Use self drill/tap screws (C) in upper track (A).
2. Measure from outside edges of tracks (D):
FasTrax, FasTrax LD
 O.D.W. + 5 1/2in [140mm] (+ 1/8in [3mm], -0)
FasTrax FR, FasTrax FR LD
 O.D.W. + 14in [356mm] (+ 1/8in [3mm], -0)
3. Determine length of track needed (E).
4. **CRITICAL:** Fasten punched angle (G) bracing at the end of the track, maintaining proper spacing.
5. Fasten bracing to diagonal (H) provide support from track to ceiling or wall.

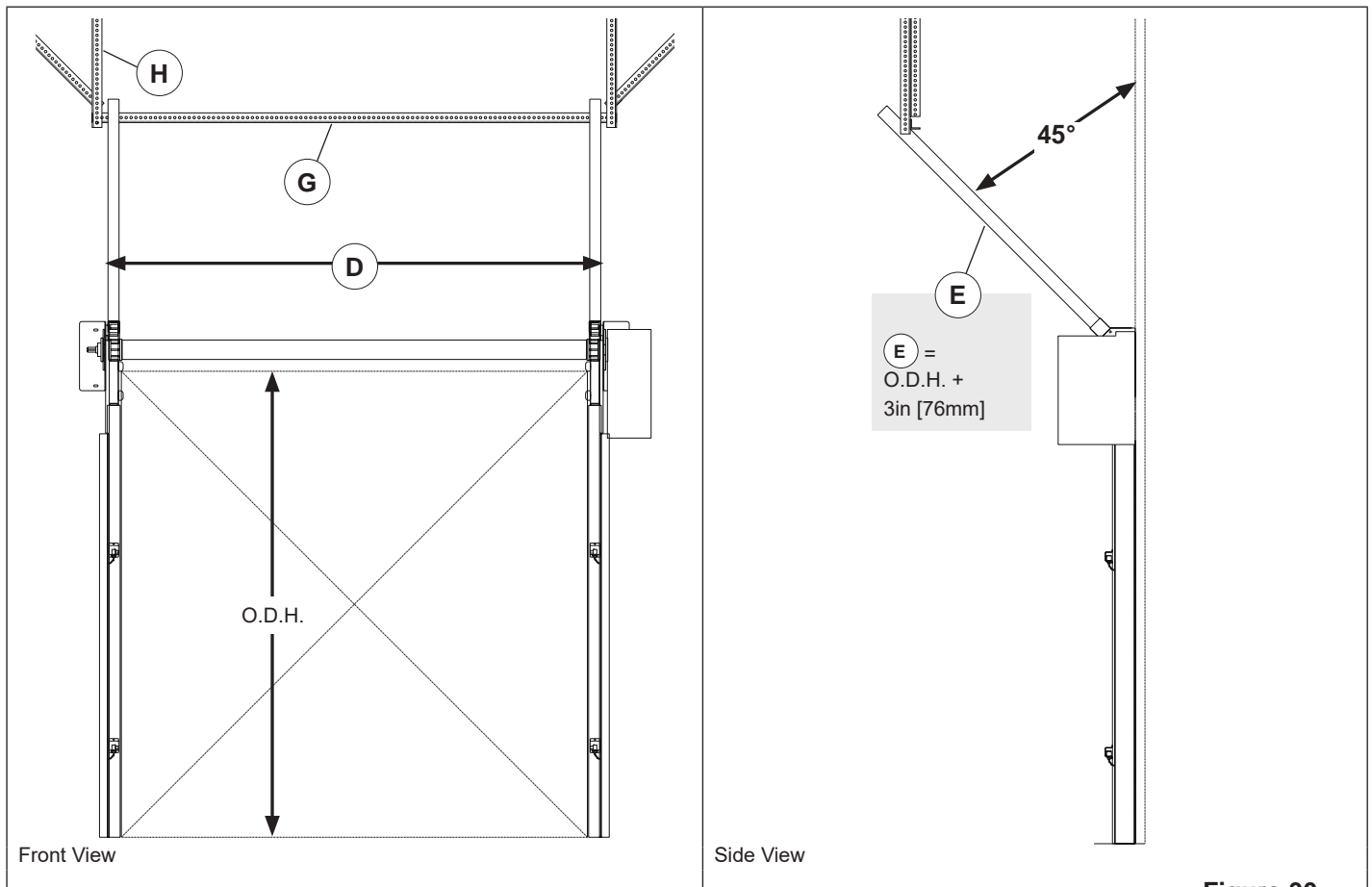

Figure 30

INSTALLATION

Drive Tube

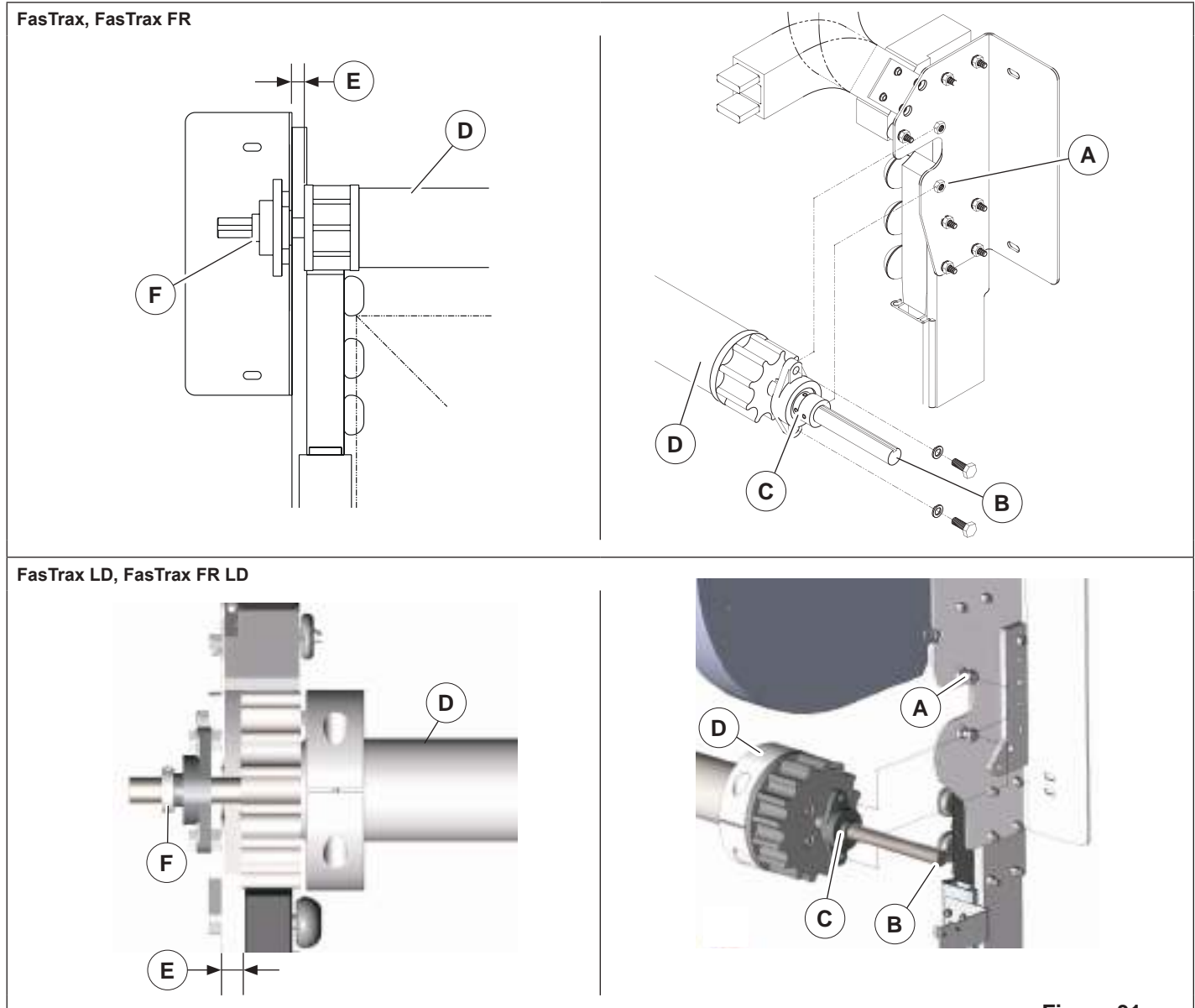

Figure 31

1. Remove the (4) 1/2in [M13] bolts and lock washers (A) from the bearing mount weld nuts on drive and non-drive sides.
2. The longer end of the shaft (B) goes on the drive side.
3. Loosen and remove lock collar on drive side.
4. Loosen non-drive lock collar, but leave on shaft.
5. Loosen bearing set screws (C).
6. Lift drive tube (D) in place and fasten the drive and non-drive bearings onto the mounting plate with the (4) 1/2in [M13] bolts and lock washers removed earlier.
7. **Critical Centering Dimension (E).** Measure from inside mounting plate to face of drive gear, $\approx 5/8$ in [16mm]. Tighten bearing set screws when this dimension is equal on both sides*.
8. Tighten non-drive lock collar (F).

* **DO NOT** tighten set screws into the keyway slot. Set screws are not long enough to provide a tight connection. Slippage and/or shaft failure may result.

INSTALLATION

Motor/Encoder (FasTrax, FasTrax FR)

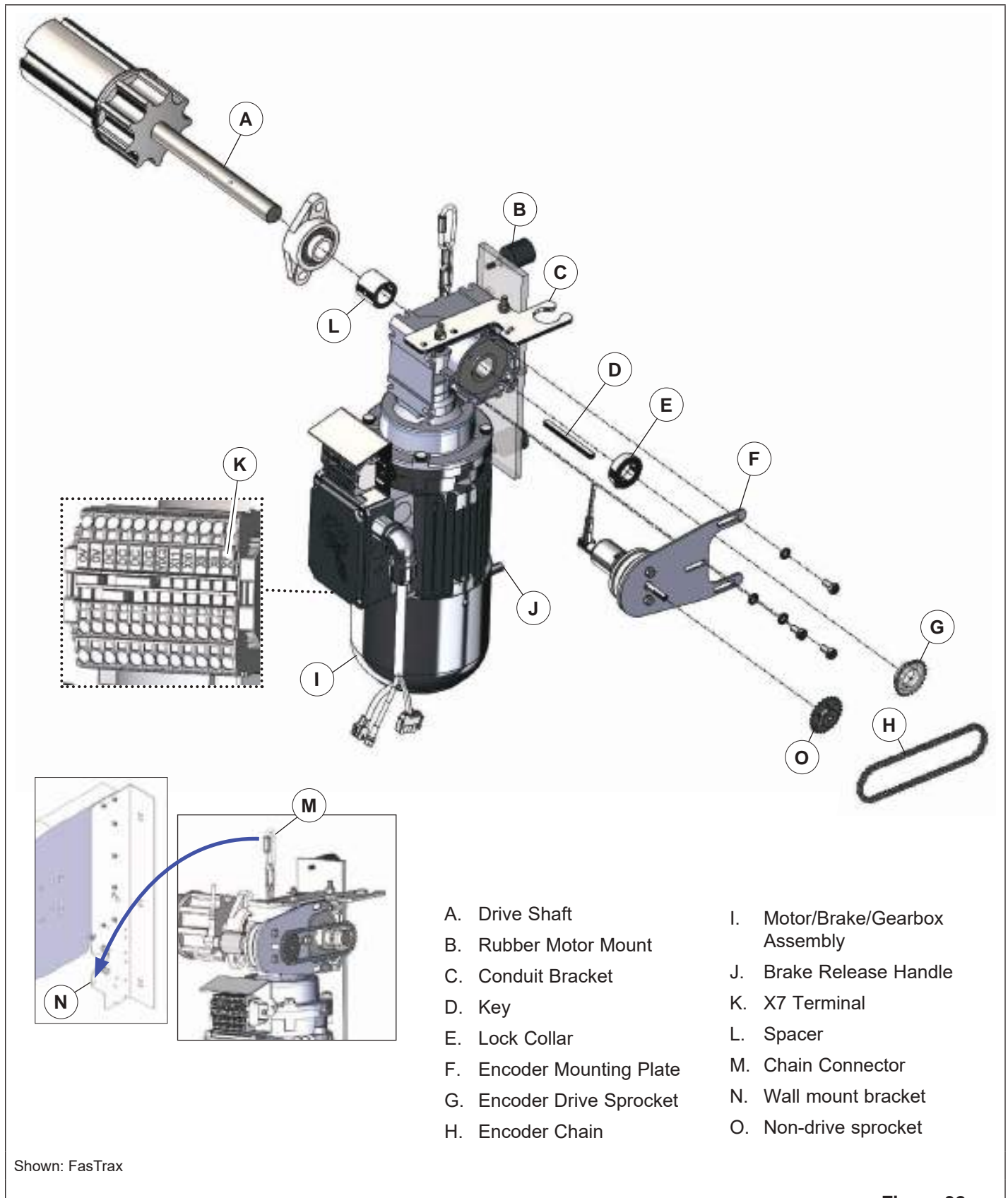

- A. Drive Shaft
- B. Rubber Motor Mount
- C. Conduit Bracket
- D. Key
- E. Lock Collar
- F. Encoder Mounting Plate
- G. Encoder Drive Sprocket
- H. Encoder Chain
- I. Motor/Brake/Gearbox Assembly
- J. Brake Release Handle
- K. X7 Terminal
- L. Spacer
- M. Chain Connector
- N. Wall mount bracket
- O. Non-drive sprocket

Shown: FasTrax

Figure 32

INSTALLATION

Motor/Encoder (FasTrax, FasTrax FR) *Continued*

1. Rotate the drive tube until the keyway slots are aligned and install key (D).
2. Re-install lock collar (E), tighten to 115in-lbs [13Nm].
3. Finger tighten all 3 bolts on encoder mounting plate (F) to gearbox (I).

NOTE: If door is equipped with N.P.O., proceed to "**N.P.O. (Non-Powered Opening) (optional)**" page 36 prior to installing encoder sprockets.

4. Slide encoder driven sprocket (O) onto the encoder shaft with hub out and even with the end of the shaft.
5. Slide encoder drive sprocket (G) onto the drive shaft (A) with hub facing out.
6. Install encoder chain (H) around sprockets (O and G).
7. Measure from each sprocket to mounting plate (F) aligning chain, apply tension and tighten mounting plate bolts.
8. Tighten set screw on drive sprocket (G) using a 3/32in allen wrench. (**DO NOT** overtighten - 5in-lbs [0.56Nm]) Sprocket does NOT require a key.

NOTE: **DO NOT** tighten set screws into the keyway slot. Set screws are not long enough to provide a tight connection. Slippage may result.

9. **IMPORTANT:** Tighten the rubber motor mounts (B) on the back of the motor mounting plate to the wall mount bracket to reduce any motor rocking. Tighten the rubber mount nuts to lock in place. After motor is wired, run to verify motor does not rock.

NOTE: If motor rocks excessively, tighten bumpers.

10. To release brake, rotate brake release handle (J) to vertical position.

NOTE:

- If removed, tighten #10-24 set screw on driven sprocket (O) using a 3/32in allen wrench (**DO NOT** overtighten - 5in-lbs [0.56Nm]).
- Drive shaft is prelubricated at the factory. If more lubricant is required, lubricate with an anti-seize lubricant.
- If side clearance is not available (minimum 18in [457mm]) to install gearbox after drive tube is installed, place gearbox onto shaft prior to installing drive tube. A lifting device will be necessary for this procedure.

INSTALLATION

Motor/Encoder (FasTrax LD, FasTrax FR LD)

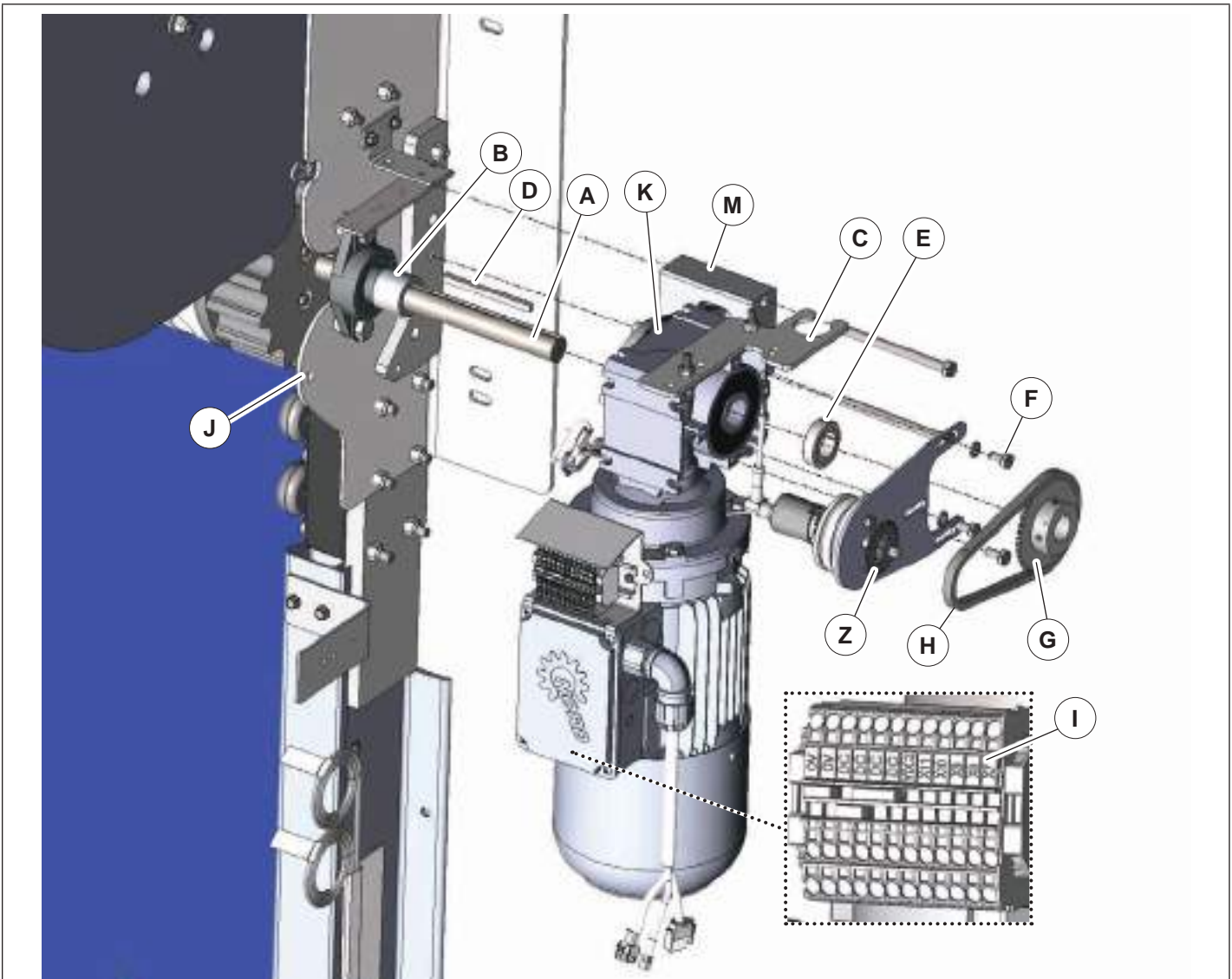

Shown: FasTrax FR LD

- | | |
|---------------------------|---------------------|
| A. Drive Shaft | H. Encoder Chain |
| B. Spacer | I. X7 Terminal |
| C. Conduit Bracket | J. Chain Connector |
| D. Key | K. Gearbox #50 |
| E. Lock Collar | L. Gearbox #63 |
| F. Top Bolt | M. Torque Arm Block |
| G. Encoder Drive Sprocket | Z. Driven Sprocket |

Figure 33

INSTALLATION

Motor/Encoder (FasTrax LD, FasTrax FR LD) *Continued*

1. Remove lock collar (E) from drive shaft (A). Slide gearbox housing onto shaft until it is against the spacer (B).
2. Rotate the drive tube until the keyway slots are aligned and install key (D). Re-install lock collar and tighten to 115in-lbs [13Nm].
3. Finger tighten all 3 bolts (F) on encoder mounting plate to gearbox.

NOTE: If door is equipped with N.P.O., proceed to "**N.P.O. (Non-Powered Opening) (optional)**" page 36 prior to installing encoder sprockets.

4. Slide encoder driven sprocket (Z) onto the encoder shaft with hub out and even with the end of the shaft.
5. Slide encoder drive sprocket (G) onto the drive shaft (A) with hub facing out.
6. Install encoder chain (H) around sprockets.
7. Measure from each sprocket to mounting plate aligning chain, apply tension and tighten mounting plate bolts (F).
8. Tighten set screw on drive sprocket using a 3/32in allen wrench. (**DO NOT** overtighten - 5in-lbs [0.56Nm]) Sprocket does NOT require a key.
9. Attach torque arm block (M) to header plate with bolts provided.

NOTE:

- If removed, tighten #10-24 set screw on driven sprocket using a 3/32in allen wrench (**DO NOT** overtighten - 5in-lbs [0.56Nm]).
 - Drive shaft is prelubricated at the factory. If more lubricant is required, lubricate with an anti-seize lubricant.
 - If side clearance is not available (minimum 18in [457mm]) to install gearbox after drive tube is installed, place gearbox onto shaft prior to installing drive tube. A lifting device will be necessary for this procedure.
 - X7 terminal (I) can be used for activation devices.
10. Fasten chain connector (M) from gearbox to hole (N) in wall mount bracket (**Figure 32**).

Motor Phasing

NOTE: If electrical is available, proceed to "**Electrical**" page 42, and then return here. If electrical is not complete, install curtain per the following:

1. With electrical complete, turn disconnect to "ON".
2. When pressing the "Open" button, the drive tube should rotate counter-clockwise on right hand drive door and clockwise on left hand drive door. (The back of the tube should be turning toward the ceiling.)
3. If the drive tube rotates in the opposite direction, switch wires in motor terminals U and V.

NOTE: Curtain needs to be stopped at or before it reaches the top of the jamb.



WARNING/AVERTISSEMENT

Failure to restrict the curtain speed can result in damage to product or injury to personnel. The curtain may close very quickly if the brake is fully released.

Releasing the brake partially will allow the door to close smoothly.

Le non-respect de restreindre le rideau vitesse peut entraîner des dommages au produit ou blesser le personnel. Le rideau peut fermer très rapidement si le frein est complètement desserré.

Relâchant le frein partiellement permettra à la porte pour la fermer sans heurts.

INSTALLATION

N.P.O. (Non-Powered Opening) (OPTIONAL)

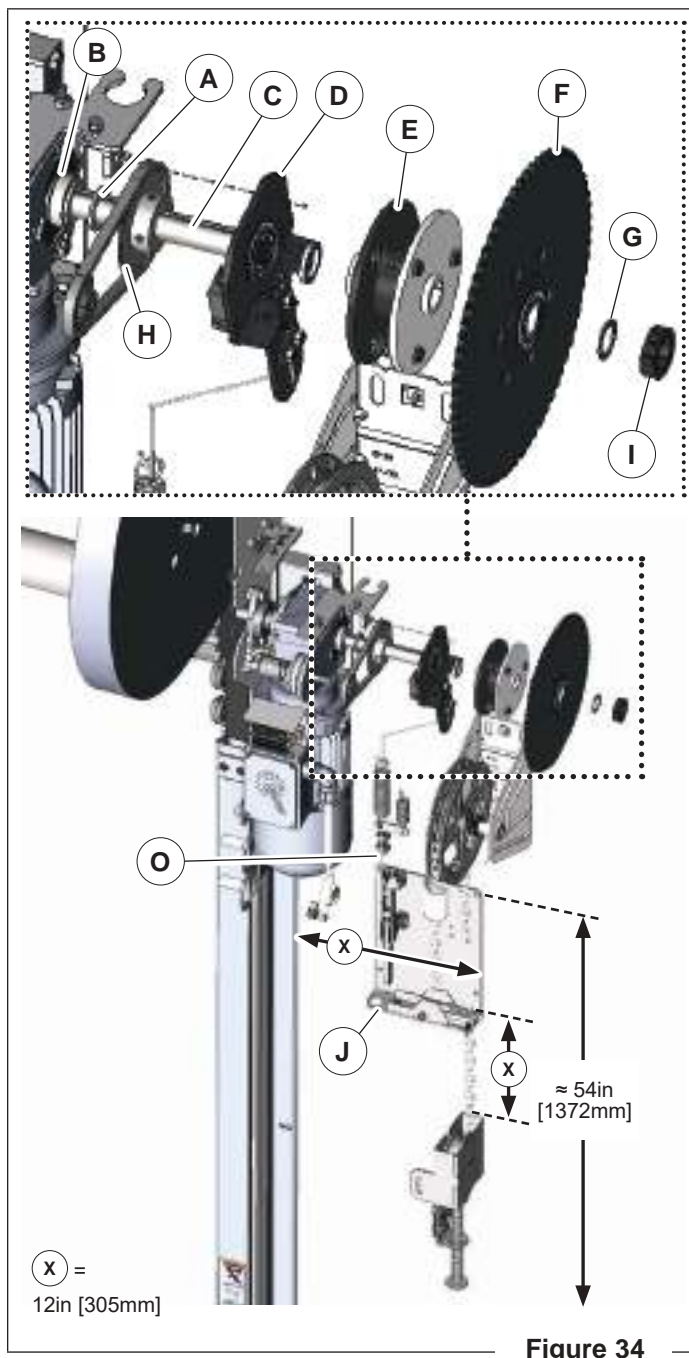

Figure 34

N.P.O. kit comes in 1 box:

NOTE: N.P.O. is assembled for a right hand drive door. To switch for a left hand drive door:

- a. Loosen the 2 side bolts and rotate the hand chain guide 180°.
- b. The fault switch must be moved to the opposite side of the engagement arm bracket (D).
- c. Remove the hand lever/chain blocker assembly (J) and rotate to opposite side of bracket.

1. Install 1/8in [3mm] spacer (A) on the outside of the lock collar (B).
2. Install encoder sprocket (H) with hub pointing away from the gearbox (Figure 34).
3. Install proper spacer (C) (according to door model) onto shaft next to the encoder sprocket. Spacers are shipped cable tied to the motor assembly.
FasTrax/FasTrax FR: 3/8in [10mm] thick spacer.
FasTrax LD/FasTrax FR LD: 1/8in [3mm] spacer.
4. Install engagement arm bracket (D) with limit switch toward gearbox.
5. Install the (2) 1/4in x 1/2in [M6 x 13mm] bolts and 1/4in [M6] lock washers through the engagement arm on the top and side to hold the bracket in place (Figure 35).

50 gearbox:

Use the rear top hole (R) and top side hole (S) (Figure 36).

63 gearbox:

Use the front top hole (T) and the bottom side hole (U).

6. Slide the engagement assembly (E) (so engagement pins are pointing away from gearbox) onto the shaft tight to the spacer and the mounting bracket and place the 3/16in x 1/4in x 2 3/4in [5mm x 6mm x 70mm] key in the keyway.
7. Slide the drive sprocket (F) onto the shaft with the hub pointing away from the gearbox.
8. Place the 1/16in [2mm] thick spacer (G) and the lock collar (I) on the shaft. Be sure to push all of the components tight to the gearbox before tightening the lock collar.

INSTALLATION

N.P.O. (OPTIONAL) *Continued*

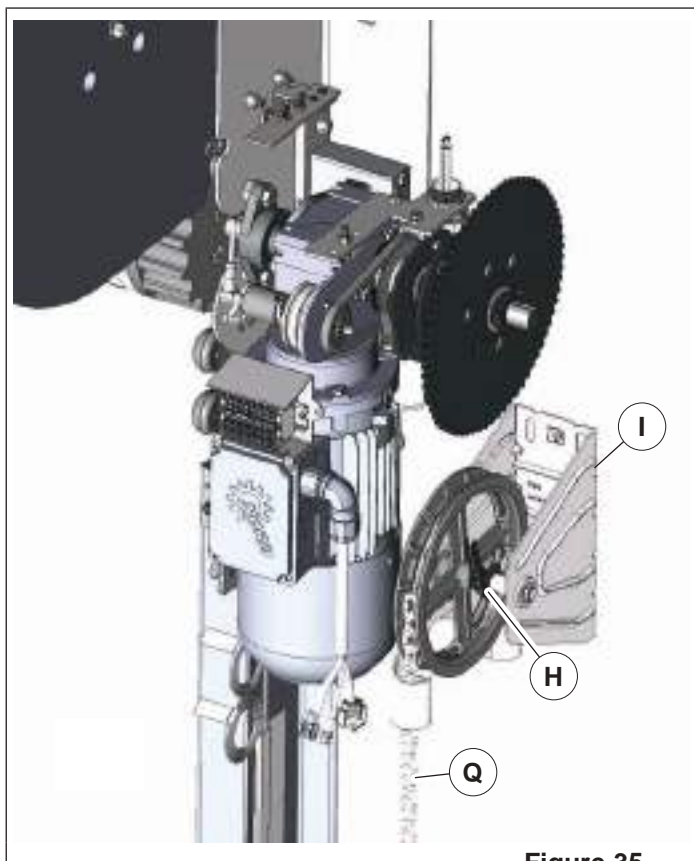

Figure 35

9. Attach the smaller of the 2 springs (K) to the brake release eye bolt (L) (Figure 37). Smaller spring should be toward the outside.
10. Route the short cable (M) through the pulley, then through the hole in the bottom of the engagement arm bracket and clamp it behind the pressure plate. The spring plate (N) should sit level when hanging without the hand lever engaged (Figure 37).
11. Place the drive chain (H) around the chain hoist sprocket and then place the drive chain over the drive tube driven sprocket (Figure 35).
12. Use a straight edge to align chain sprockets. Failure to do so may result in noise and premature wear.
13. With the hand chain sprocket in toward the motor and the sprocket in line with the drive sprocket, plumb, level, mark and drill hole locations (toward bottom of the slot, to prevent chain hoist from sliding up) for fastening chain hoist assembly (I) to the wall. Use fasteners suitable to hold unit to the wall.
14. Make sure chain is tight and not causing either shaft to bend.

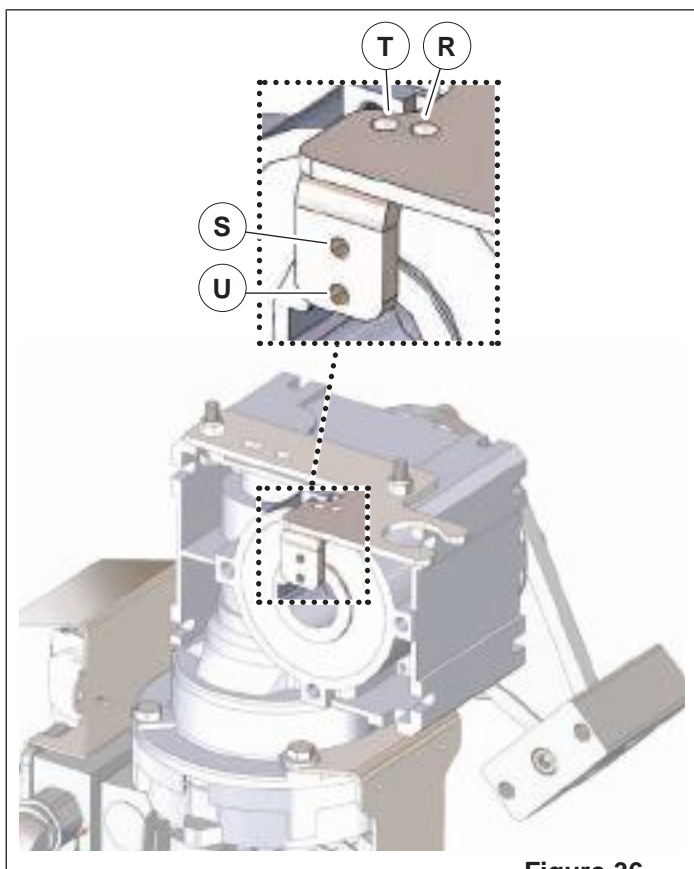

Figure 36

INSTALLATION

N.P.O. (OPTIONAL) *Continued*

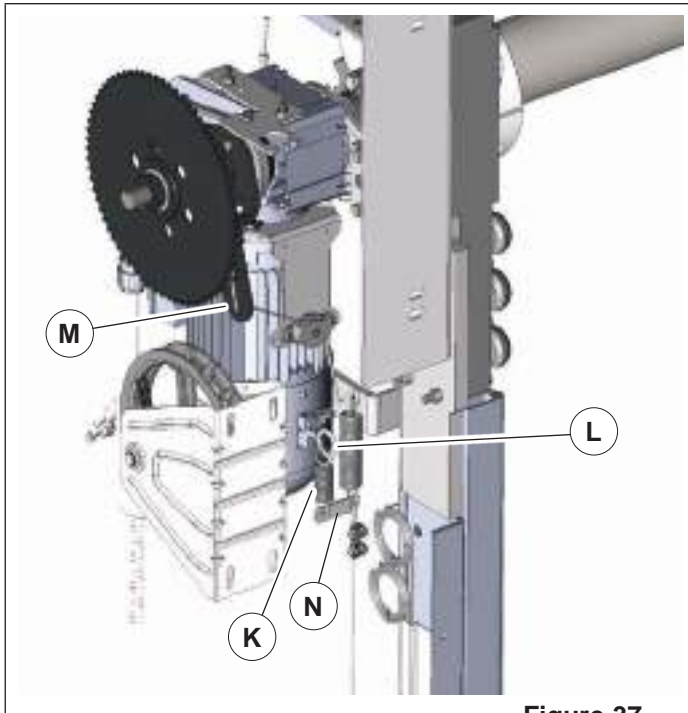

Figure 37

15. Mount the hand lever/chain blocker assembly (J) at a convenient height off the floor, ≈ 54in [1372mm] to top of plate so the hand lever is easily accessed. Align with brake hand lever and chain hoist, ≈ 11-12in [305mm] from lower track to outside mounting holes. Use fasteners suitable to hold unit to the wall (**Figure 34**).
16. Install chain tensioner in line with hole in hand lever/chain blocker assembly and at least 12in [305mm] below the assembly so it does not interfere with operation.
17. Install the hand chain (Q) (**Figure 35**) onto the chain hoist, down through hole in hand lever/chain blocker assembly and around chain tensioner pulley. The chain links can be taken apart to achieve the length needed.
18. Route the longer cable (O) (**Figure 34**) attached to the hand lever up through the larger hole on the spring plate (N) (**Figure 37**).
19. Adjust the cable so that when the hand lever is down, the assembly is fully engaged into the sprocket and when the lever is up, the engagement assembly is not touching the sprocket. Tighten both cable clamps.
20. With the hand lever completely down, pull the hand chain to move the door. Disengage the chain hoist and confirm that the chain hoist and sprocket spin but the door does not move.
21. Connect the switch cable to the cable coming out of the control box conduit. Secure wires away from moving parts.
22. Reset and run the door. Confirm that the sprocket and chain hoist do not turn when the door moves. With the door stopped, rotate the hand lever down and confirm that the door operation is disabled by the switch.
23. Proceed to drive shroud installation on [page 65](#) for attaching additional mounting bracket. Confirm that there is clearance for the cable conduit and hand chain when using the chain hoist.

NOTE: The door will not operate until the chain hoist is installed and plugged in.

INSTALLATION

N.P.O. (OPTIONAL) *Continued*

Power Outage Procedure

Follow lockout procedures to prevent the door from operating should power be restored while working on.

Counterweight or through-wall brake release is not available.

Use a Non-Powered Manual Open option for opening or closing the door in the event of a power outage.



WARNING/AVERTISSEMENT

N.P.O. (Non-Powered Opening) is intended to operate door in the event of a power loss.

Disconnect power during any other operation.

N.P.O. (OHT/L'ouverture non motorisée) est destinée à actionner la porte en cas de panne de courant.

Débrancher l'alimentation pendant toute autre opération.

N.P.O. Equipped:

1. To release brake and engage N.P.O., rotate the hand lever completely down.
2. To raise the door - pull the front hand chain down.
3. To lower the door - lift the chain blocker and pull the rear hand chain down.

NOTE: The chain blocker prevents the door from closing. Once the hand lever is pulled, the door goes into fault and cannot be automatically operated and the screen will display "Door Faulted, Emergency Stop".

To Return Door to Operation:

1. Engage brake and release N.P.O. by rotating the hand lever up and lock in place.
2. Hand chain should rotate freely, ensuring assembly is disengaged.
3. Reconnect power. Press green Open/Reset button.

NOTE: In the event that the curtain is lowered or raised beyond the drive tube, the encoder positions will need to be re-setup.

Without N.P.O.



CAUTION/ATTENTION

Use caution with lift configurations. The weight of the curtain may cause the curtain to close rapidly.

Soyez prudent avec les configurations d'ouverture. Le poids du rideau peut provoquer sa fermeture rapide.

NOTE: Procedure should only be performed by trained technicians.

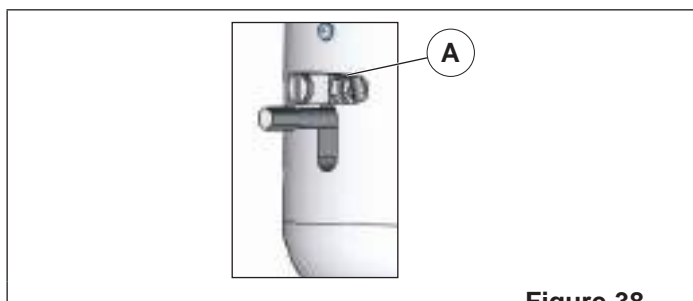

Figure 38

1. On the door mounted side, a ladder or a scissors lift will be required to release the brake.
2. To hold brake release on, rotate brake release hold down bracket (A) to vertical position.
3. To engage brake, rotate bracket horizontal.
4. While the brake is released, turn the roller tube to lower or raise the door. The force required will vary based on size and lift configuration.

NOTE: The roller tube can be turned by hand or a wrench placed on the non-drive shaft and turned.

INSTALLATION

Curtain

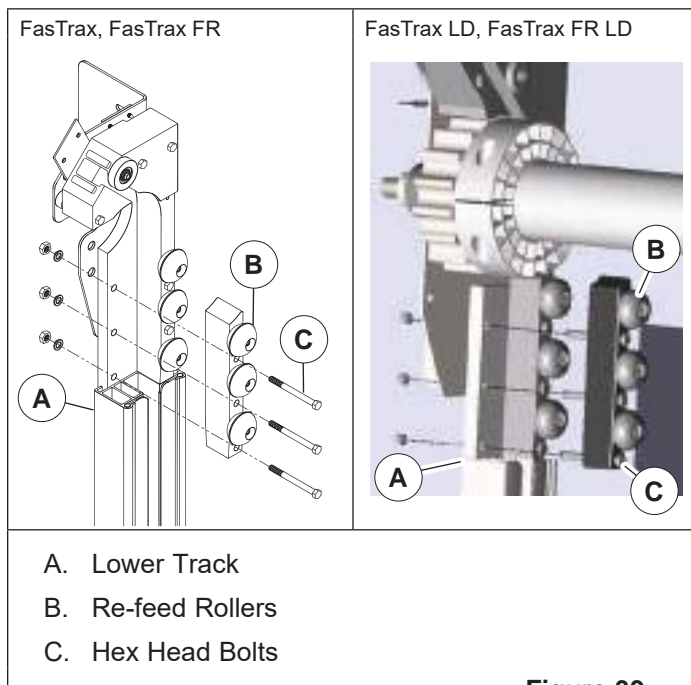

Figure 39

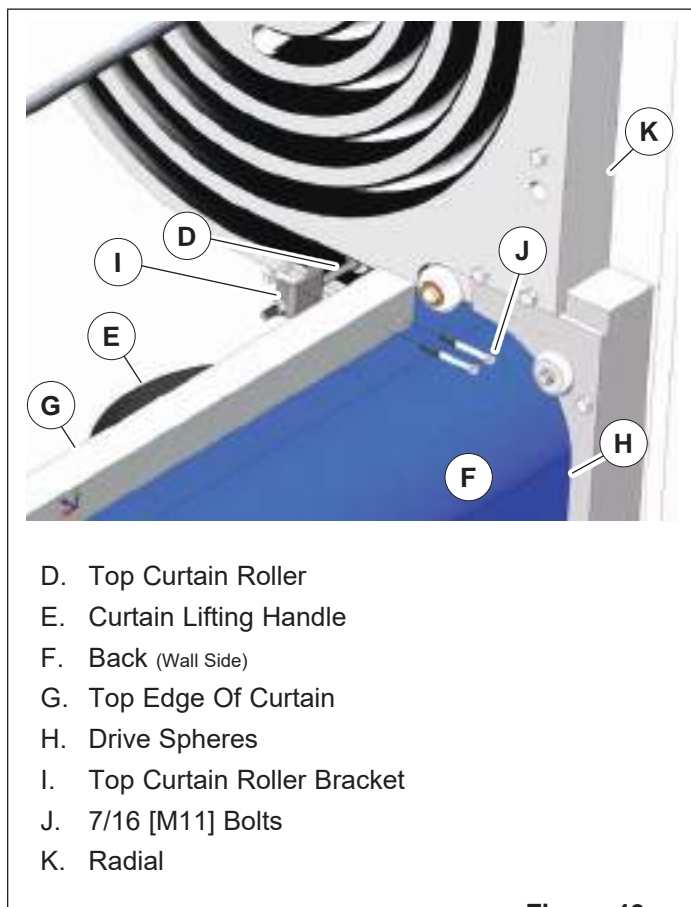

Figure 40

1. Remove the (3) 3/8in [10mm] hex head bolts (C) holding the front curtain retainers in place (both sides).
2. Top curtain roller bracket (I) should be positioned so the roller shaft is toward the curtain and away from the wall.
Remove plastic wrap, (2) 7/16in [M11] bolts (J) and both top curtain rollers (D) to feed through drive gears.
3. Verify there is a wall surface at the header for the rear top seal to seal against. If not, a surface must be provided in order for curtain to seal to wall.
4. Disengage brake by pulling the brake release handle on the brake and locking in place by rotating brake release handle down to vertical position.
5. Place curtain in front of the opening so that the top edge (G) with the metal stiffener is facing the wall. Curtain may be either a standard or insulated curtain.
6. Raise curtain and feed top drive sphere around the back (wall) side (F) of the drive gear and into the radial (K) and/or upper track ≈ 6in [152mm] by rotating drive tube to drive curtain through the drive gears.
7. Release brake release handle to hold curtain.
8. Fasten curtain top roller bracket back onto the top edge of curtain (G).
9. Once top rollers are securely fastened, disengage brake and continue to route curtain through opening in lower track.

INSTALLATION

Curtain *Continued*

FasTrax, FasTrax LD

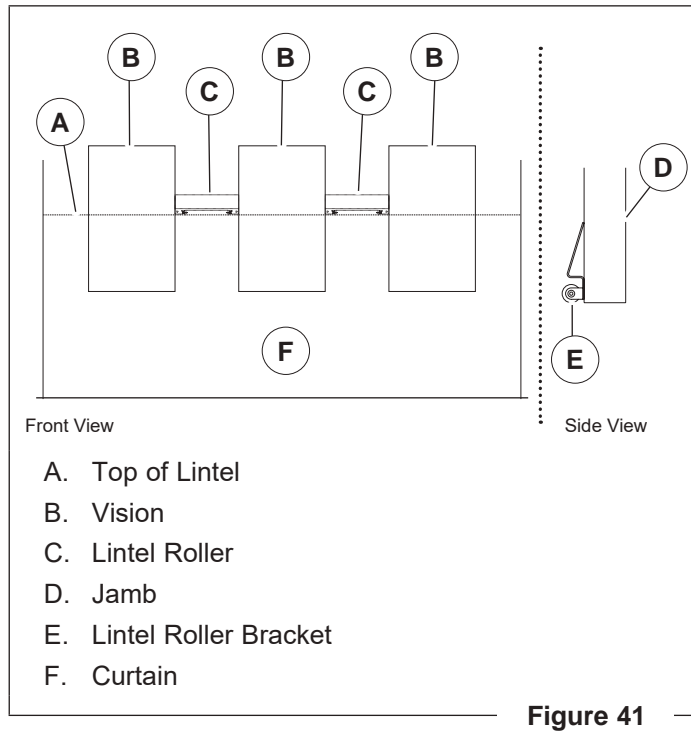

1. Place curtain so the vision is at the lintel. Place a mark on the wall at the center of visions and install lintel roller (C). If no vision, space evenly.
DO NOT place over vision area.
2. Mount the lintel roller bracket (E) on the front face of the jamb with bottom of roller flush with jamb.
DO NOT install on underside of jamb.

INSTALLATION

Electrical

⚠ DANGER

Per local electrical codes, when working with electrical or electronic controls:

- Power source must be locked out and marked
- A qualified electrician should install the wiring

Selon les codes électriques locaux, lorsque vous utilisez des commandes électriques ou électroniques:

- La source d'alimentation doit être verrouillée et marquée
- Un électricien qualifié doit installer le câblage

⚠ DANGER

To reduce risk of injury or death, an earth ground connection must be made to the green/yellow control box ground terminal.

If metal conduit is used as the ground connector, a ground bushing and green/yellow wire must be properly attached to the conduit for connection to the ground terminal, per local electrical codes.

Pour réduire le risque de blessures ou de décès, un raccordement de terre doit être fait à la boîte de contrôle verte/jaune de la borne de terre.

Si le connecteur de terre utilisé est un conduit métallique, un manchon de mise à la terre et un câble vert/jaune doivent être correctement fixés au conduit un raccordement à la borne de terre, par codes électriques locales.

NOTICE

DO NOT drill holes on top of control box to run conduit, as dust particles and moisture may cause damage to electrical components. The safest location is at the bottom. Failure to do so will void warranty.

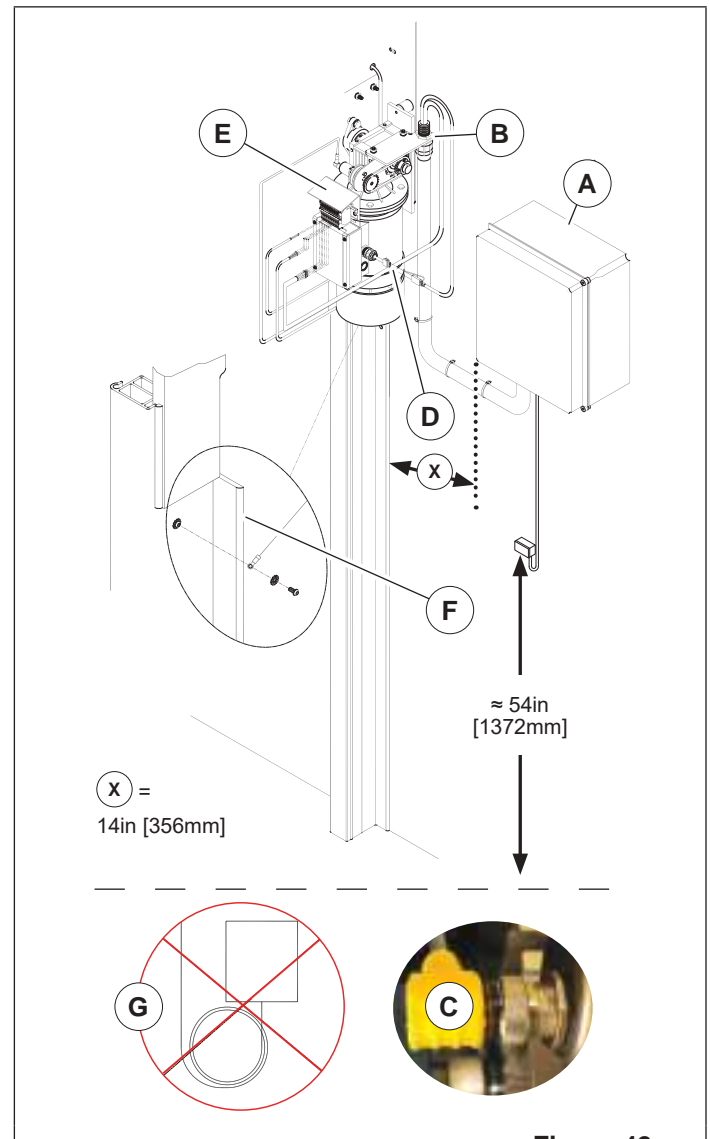

Figure 42

INSTALLATION

Electrical *Continued*

1. It is the responsibility of the end user to provide electrical service up to the control box (A) with proper branch service protection and an approved means of disconnect.

NOTE: Wire size may need to be increased to prevent excessive voltage drop. Consult local and/or national electrical codes.

2. Rite-Hite recommends mounting the control box high. If necessary to mount the control box low, mount control box adjacent to the door at \approx 54in [1372mm] above the floor and 14in [356mm] from side support post.
3. The control box cable is pre-wired to the control box. Attach control box cable to the conduit mounting bracket (B) on the gearbox.

Connect motor, brake cables and fasten terminal strip (E) to the motor junction box using the top 2 screws, making sure unit is properly sealed. If the flexible conduit is too long, unwire control box cable wires and cut the protective outer casing the required amount.

DO NOT coil (G) or let conduit hang on the floor.

NOTE: X7 terminal (I) (**Figure 33**) can be used for activation devices.

4. If local electrical codes require the use of rigid conduit:
 - Remove conduit connector and control cables from the flexible conduit.
 - Install the rigid conduit in its place and rewire.
5. If possible, mount on the warm side regardless of door mount side.
6. In freezer and cooler applications where a conduit passes from a warm to cold temperature zone, the conduit must be plugged with epoxy.

This will help prevent condensation from forming in the conduit.
7. All holes drilled must be through the bottom of the control box. Conduit entering the sides or top of the enclosure will void the warranty.
8. Use the proper sealed connectors to maintain the rating on the enclosure.
9. Line up pins and connect encoder cable (C) to encoder. Verify connector is tight. **DO NOT** over tighten as pins will twist. When tight, the connector should not be able to move back and forth.

10. Connect 4 pin motor, 2 pin brake connector and single connector if heated brake is present (D).
11. Attach ground wire to lower track (F).
12. Incoming single or 3-phase power must connect into fuse holder terminals F1, F2, F3 and ground terminal. Terminals in the control box will not accommodate wires larger than 12AWG [2.05mm].
13. Route all field installed wires so that separation is maintained between line voltage wires and low voltage class II wiring.
14. The control box is provided with class CC protective fusing for the incoming power.
15. Clamp conduit to wall after complete.
16. Refer to electrical diagrams included with door.

NOTE: DO NOT splice control wiring.

INSTALLATION

Electrical *Continued*

Control Box (FSTX/FSTXLD)

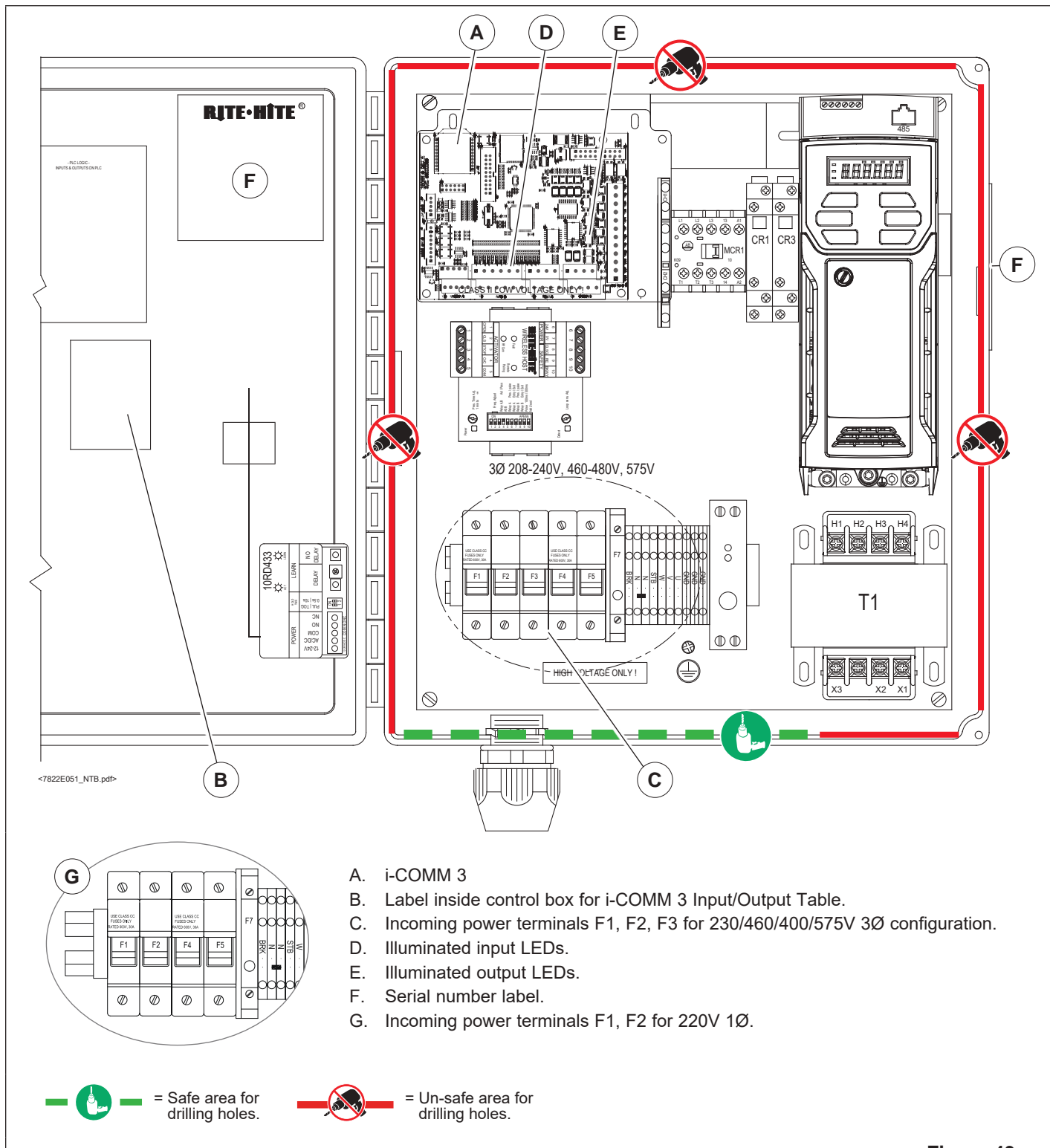

Figure 43

INSTALLATION

Electrical *Continued*

Virtual Vision (OPTIONAL)

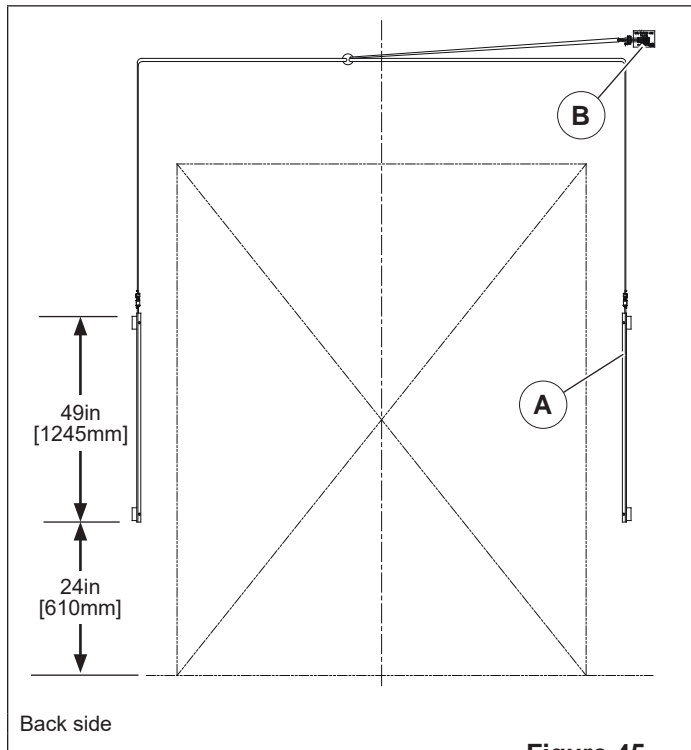

Figure 45

There will be a motion sensor mounted on each side of the door, as well as 2 red LED Virtual Vision light bars on each side of the opening on both sides. The motion sensors will detect motion on the opposite side of the curtain to warn oncoming traffic of a possible pedestrian or forklift on the opposite side.

1. Install Virtual Vision light bar assemblies (A):
 - Left/right and front/back of the doorway.
 - In clear view of oncoming traffic.
 - ≈ 24in [610mm] above the floor, adjacent to the doorway (e.g. goal posts or wall).
 - In a location protected from potential impact damage.
2. Install Virtual Vision motion sensors (B), on both sides of the door.
 - a. Direct sensors so they **DO NOT** extend beyond the width of the door.
 - b. Program sensors for a 2 second hold time and bi-directional detection.
3. Plug cables into light strips, and wire into:
 - FasTrax/FasTrax LD - Virtual Vision junction box.
 - FasTrax FR/FasTrax FR LD - Motor Mounted Terminal strip.
4. See "[Field Wiring Virtual Vision Wiring Diagram – FasTrax/FasTrax LD](#)" on page 56 and "[Field Wiring Virtual Vision Wiring Diagram – FasTrax FR/FasTrax FR LD](#)" on page 57 for terminations.

INSTALLATION

Electrical *Continued*

Falcon Motion Sensors

1. To avoid cross talk when changing the settings on the Virtual Vision or activation sensors when using the remote controls, Rite-Hite offers the following 3 options:
 - a. The BEA remote control allows you to set a unique security code for each sensor. This allows you to change the settings for individual sensors. To create security codes:
 - Temporarily disconnect the activation sensor(s) from its power supply (at the i-COMM 3).
 - Use the remote to set a security code (e.g. "1111") for the Virtual Vision sensor(s).
 - Power up all sensors.
 - The activation sensor will have the default security code "0000" for its settings, and the Virtual Vision sensor will have its new security code (use unlock/lock sequence).
 - There should be no cross-talk with the remote's instructions when using this approach.
 - Record the new security code values for future reference.
 - b. If you do not wish to use security code settings, power down 1 unit at a time, while setting the other unit. Do the same thing with the other unit. This is similar to option "a", although if you want to make subsequent changes to the settings, you would need to go through the power down procedure again.
 - c. If you do not wish to power down the units or use security settings, you can physically cover 1 of the units while programming the other unit. Any opaque material (e.g. cardboard) should work. This may be difficult for units mounted high above the opening.

Curtain Fan

1. Install curtain fan(s) off to the side of the door jamb, near the top of the opening.
 - a. Adjust fan to move air parallel to the curtain from the top to the opposite lower corner.
 - b. **DO NOT** aim the fans to blow air into the cooler/freezer.
 - c. If door is mounted on cold side, install fans on warm side.

NOTE: Fan(s) may be turned off if there is no moisture present.

INSTALLATION

Electrical *Continued*

Mandatory Field Wiring Diagram – FasTrax/FasTrax LD

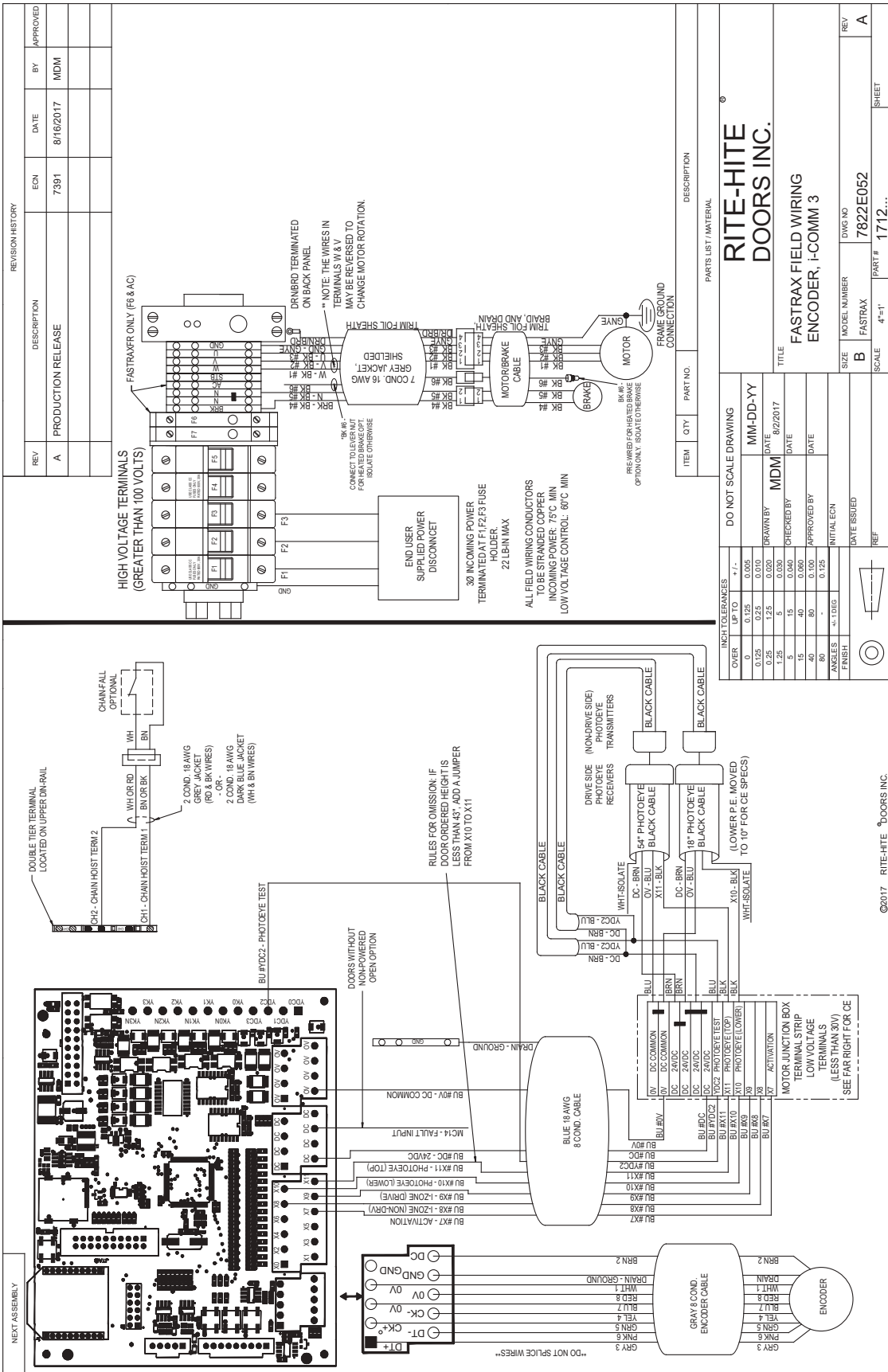

1 2 3 4

©2017 RITE-HITE DOORS INC.

47822E052_190305.pdf

INSTALLATION

Electrical *Continued*

NOTE: Brake will heat when the temperature is below 35°F [1.67°C] and motor is not running.

A frozen brake may take up to 60 minutes to thaw when power is applied. This time depends on ambient temperature and the amount of ice accumulation.

Motor Wiring – FasTrax/FasTrax LD

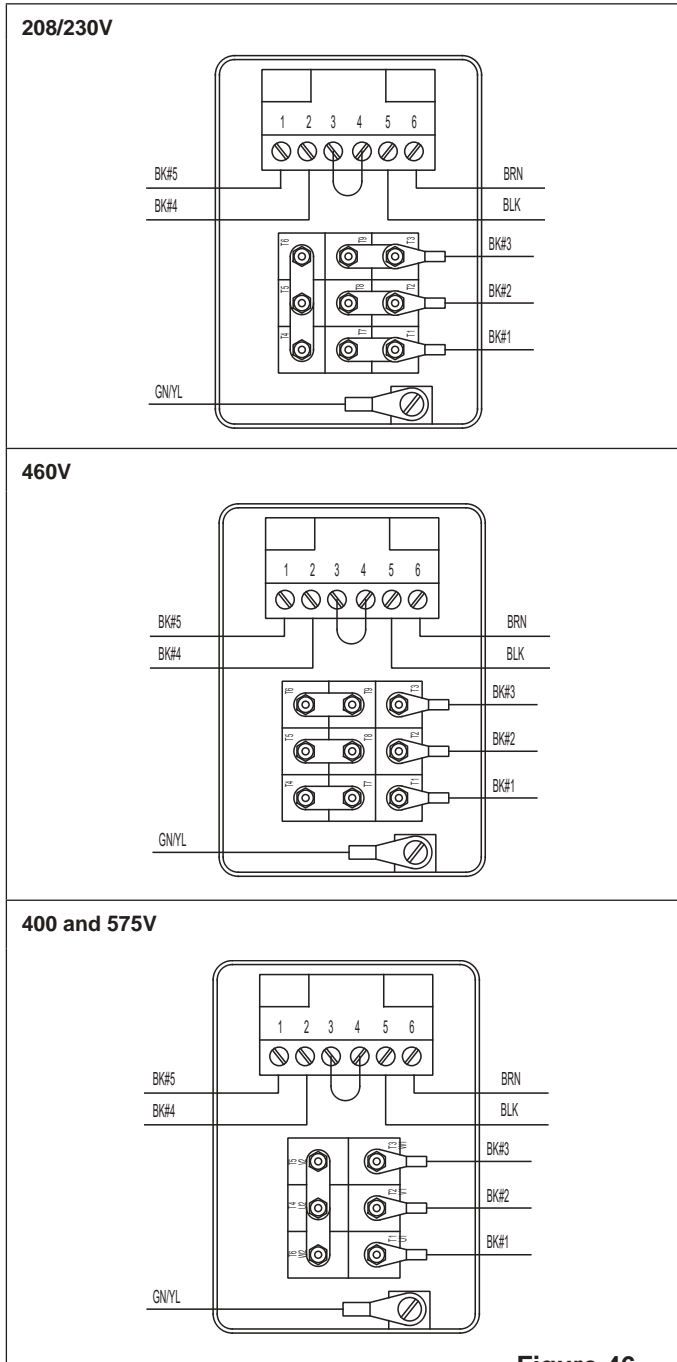

Figure 46

Motor Wiring – FasTrax FR/FasTrax FR LD

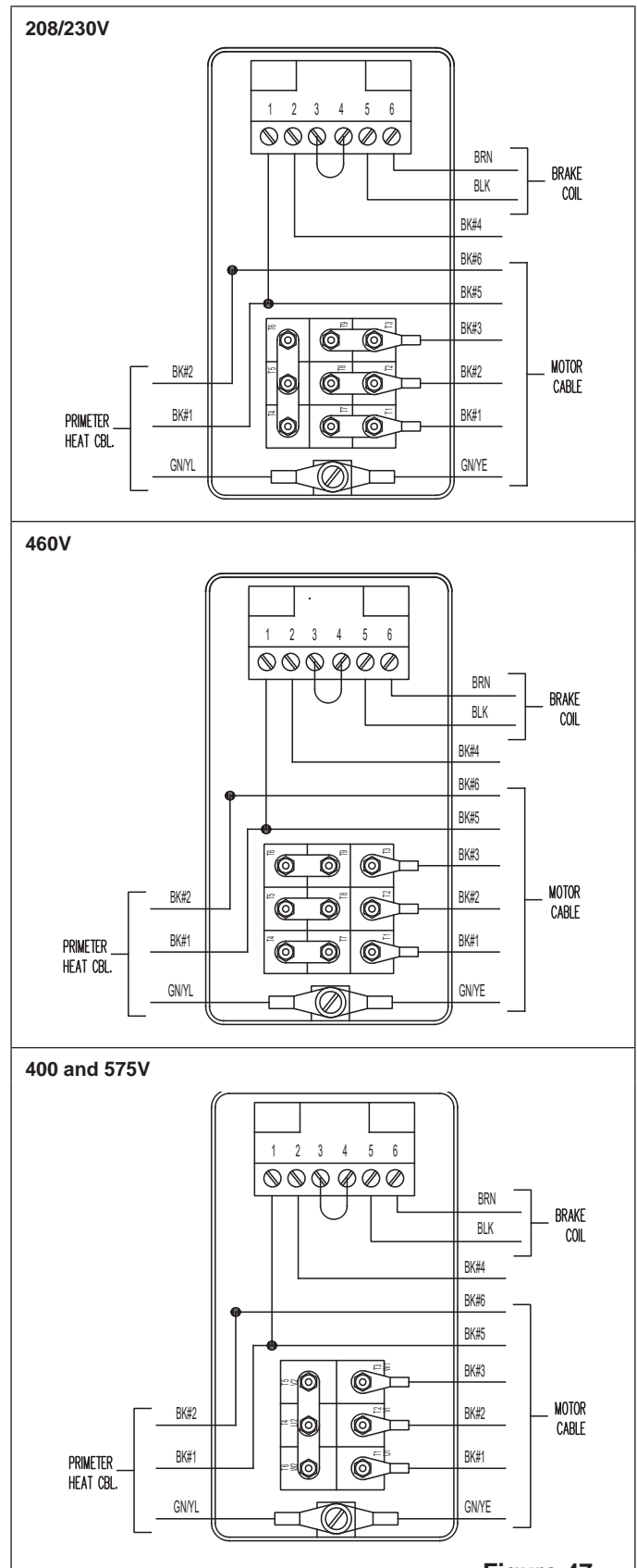
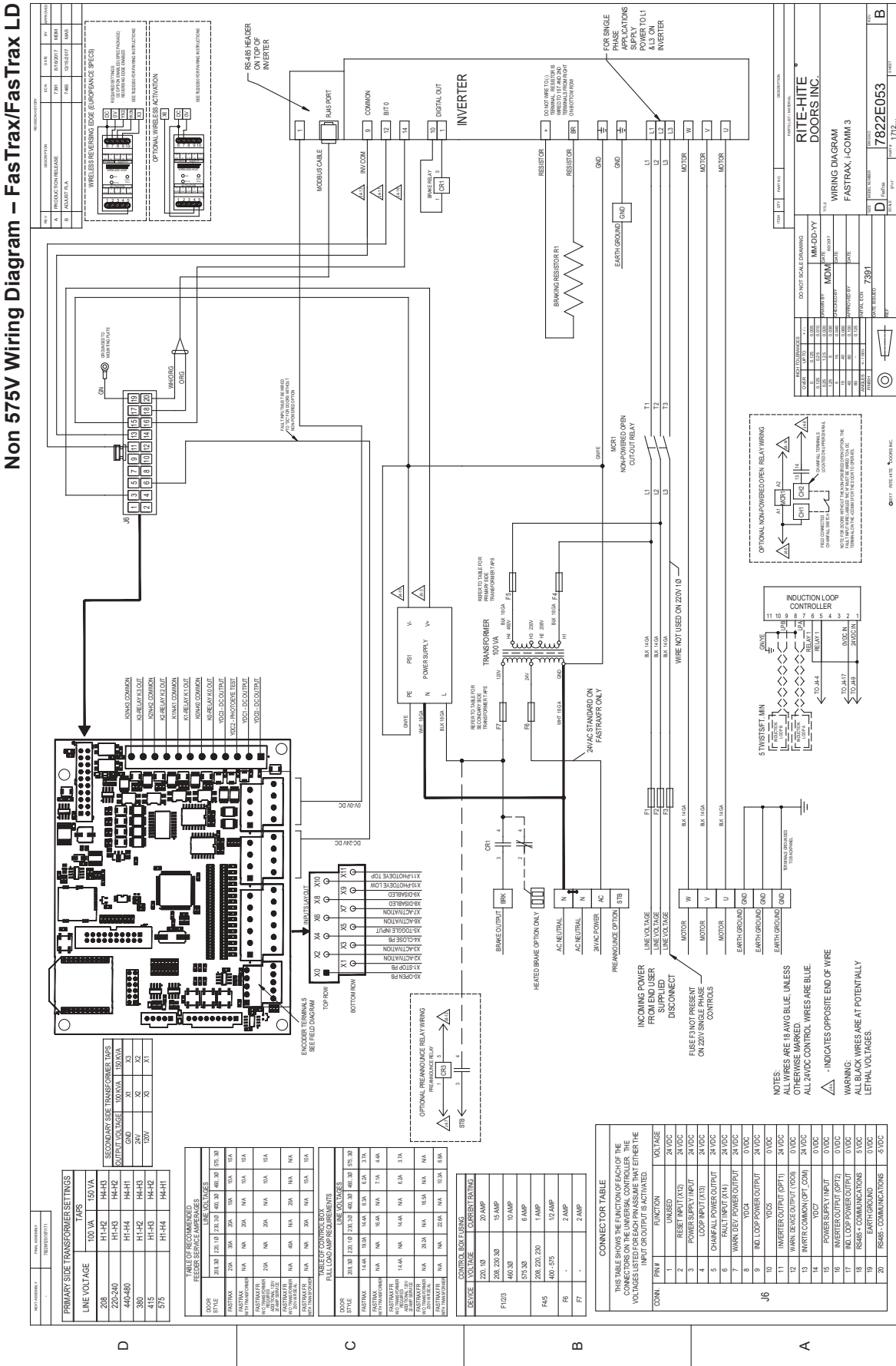

Figure 47

INSTALLATION

Electrical *Continued*

Non 575V Wiring Diagram – FasTrax/FasTrax LD



NOTES:
 ALL WIRES ARE 18 AWG BLUE UNLESS OTHERWISE MARKED.
 ALL 24VDC CONTROL WIRES ARE BLUE.
 Δ INDICATES OPPOSITE END OF WIRE.
 WARNING: ALL BLACK WIRES ARE AT POTENTIALLY LETHAL VOLTAGES.

OPTIONAL NON-POWERED OPEN RELAY WIRING

INDUCTION LOOP CONTROLLER

CONNECTOR TABLE

THIS TABLE SHOWS THE FUNCTION OF EACH OF THE CONNECTORS ON THE UNIVERSAL CONTROLLER. THE VOLTAGES LISTED FOR EACH PNF ASSUME THAT EITHER THE SUPPLIED OR INPUT OR OUTPUT IS AVAILABLE.

TABLE OF TRANSFORMER SETTINGS

TABLE OF RESOURCES

TABLE OF CONTROL BOX FULL LOAD AMP REQUIREMENTS

DOOR STYLE | **LINE VOLTAGE** | **FULL LOAD AMP REQUIREMENTS**

FASTRAK | 208-240 | 15.0A

FASTRAK | 300 | 20.0A

FASTRAK | 415 | 25.0A

FASTRAK | 475 | 30.0A

TABLE OF TRANSFORMER SETTINGS

DOOR STYLE | **LINE VOLTAGE** | **PRIMARY SIDE TRANSFORMER SETTINGS**

208 | 100 VA | 100V

220-240 | 150 VA | 150V

300 | 200 VA | 200V

415 | 300 VA | 300V

475 | 400 VA | 400V

TABLE OF RESOURCES

DOOR STYLE | **LINE VOLTAGE** | **RESOURCES SERVICE AMPERAGES**

FASTRAK | 208-240 | 15.0A

FASTRAK | 300 | 20.0A

FASTRAK | 415 | 25.0A

FASTRAK | 475 | 30.0A

TABLE OF CONTROL BOX FULL LOAD AMP REQUIREMENTS

DOOR STYLE | **LINE VOLTAGE** | **FULL LOAD AMP REQUIREMENTS**

FASTRAK | 208-240 | 15.0A

FASTRAK | 300 | 20.0A

FASTRAK | 415 | 25.0A

FASTRAK | 475 | 30.0A

CONNECTOR TABLE

CONN | **PNF#** | **FUNCTION** | **VOLTAGE**

1 | 1 | POWER SUPPLY (V) | 24 VDC

2 | 2 | POWER SUPPLY (W) | 24 VDC

3 | 3 | POWER SUPPLY (U) | 24 VDC

4 | 4 | LOOP INPUT (X3) | 24 VDC

5 | 5 | CHANCE ALL POWER OUTPUT | 24 VDC

6 | 6 | FAULT INPUT (X4) | 24 VDC

7 | 7 | WARN LIEV/POWER OUTPUT | 24 VDC

8 | 8 | Y0/24 | 0 VDC

9 | 9 | IND LOOP POWER OUTPUT | 24 VDC

10 | 10 | Y0/24 | 0 VDC

11 | 11 | INVERTER OUTPUT (OPT1) | 24 VDC

12 | 12 | WARN LIEV/OUTPUT (Y0/24) | 0 VDC

13 | 13 | WARN COMMON/OPT (Y0/24) | 0 VDC

14 | 14 | POWER SUPPLY (V) | 0 VDC

15 | 15 | INVERTER OUTPUT (OPT2) | 0 VDC

16 | 16 | IND LOOP POWER OUTPUT | 0 VDC

17 | 17 | RS485 - COMMUNICATIONS | 5 VDC

18 | 18 | RS485 - COMMUNICATIONS | 5 VDC

19 | 19 | EARTH/GROUND | 0 VDC

20 | 20 | RS485 - COMMUNICATIONS | -5 VDC

WIRING DIAGRAM
 FASTRAX, I-COMM 3

7822E053

1

2

3

4

5

6

7

8

© 2017 RITE-HITE DOORS INC.

INSTALLATION

Electrical *Continued*

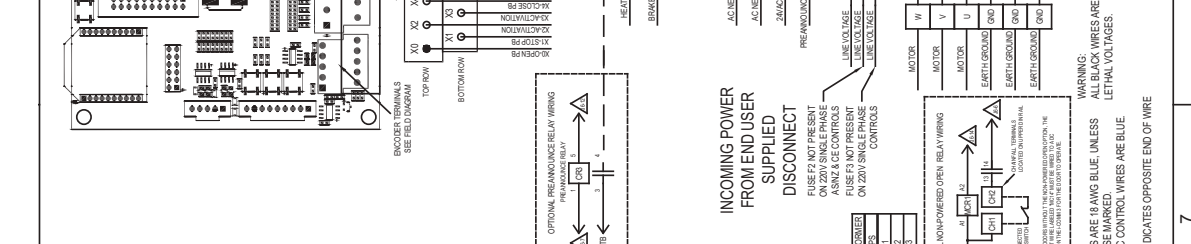
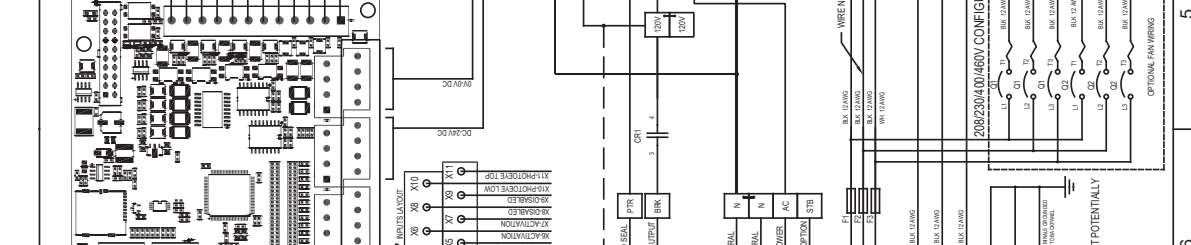
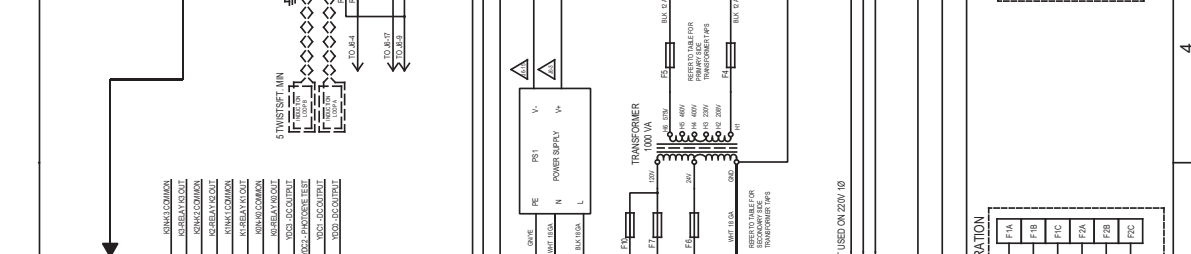
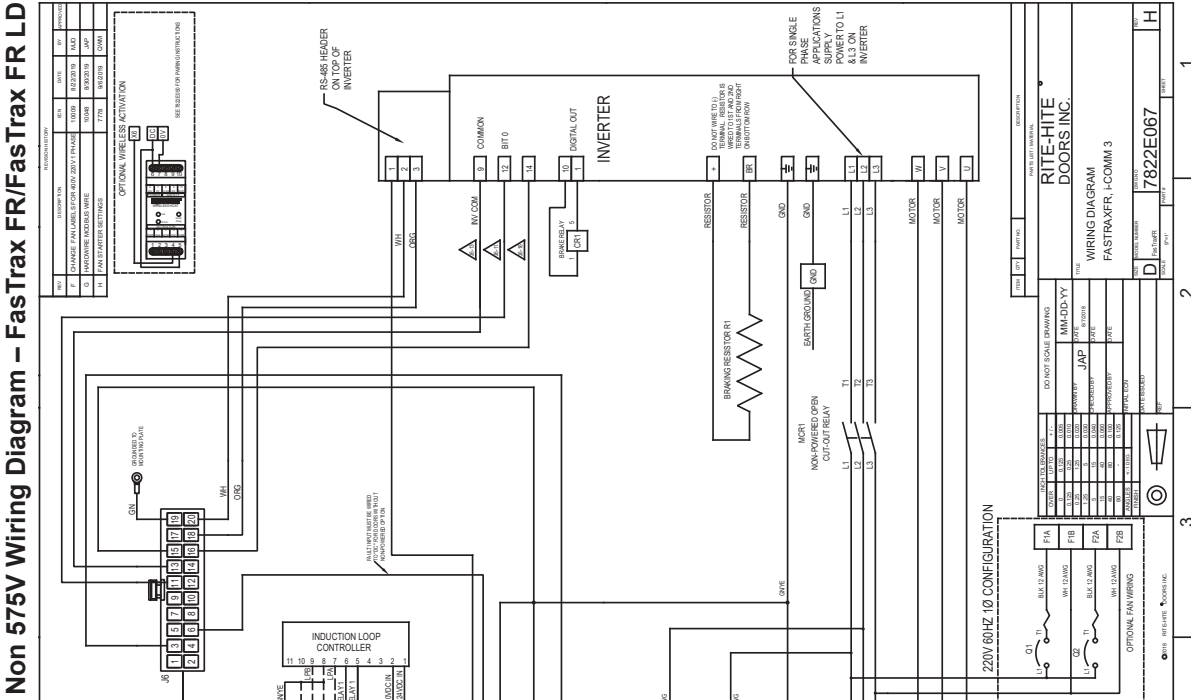

CONN.	PAIRS	FUNCTION	VOLTAGE
1	UNSHIELD	24VDC	24VDC
2	RESET INPUT (R2)	24VDC	24VDC
3	POWER SURVEY INPUT	24VDC	24VDC
4	LOOP INPUT (A13)	24VDC	24VDC
5	CHANGEOVER POWER OUTPUT	24VDC	24VDC
6	FAULT INPUT (F4)	24VDC	24VDC
7	WORK LIGHT POWER OUTPUT	24VDC	24VDC
8	VOLTS	0VDC	0VDC
9	NO LOOP POWER OUTPUT	24VDC	24VDC
10	INVERTER OUTPUT (P12)	0VDC	0VDC
11	INVERTER OUTPUT (P11)	24VDC	24VDC
12	WARRANTY CODE OUTPUT (V20)	0VDC	0VDC
13	INVERTER COMMON (P1)	24VDC	24VDC
14	VOLTS	0VDC	0VDC
15	POWER SURVEY INPUT	0VDC	0VDC
16	INVERTER OUTPUT (P12)	0VDC	0VDC
17	NO LOOP POWER OUTPUT	0VDC	0VDC
18	RS-485 - COMMUNICATIONS	5VDC	5VDC
19	EARTH/GROUND	0VDC	0VDC
20	RS-485 - COMMUNICATIONS	-5VDC	-5VDC

CONTROL	SETTING
1	25 AMP
2	20 AMP
3	10 AMP
4	6 AMP
5	2 AMP
6	4.5 AMP

CONTROL	SETTING
1	25 AMP
2	20 AMP
3	10 AMP
4	6 AMP
5	2 AMP
6	4.5 AMP

CONTROL	SETTING
1	25 AMP
2	20 AMP
3	10 AMP
4	6 AMP
5	2 AMP
6	4.5 AMP

INCOMING POWER FROM END USER SUPPLIED DISCONNECT FUSE F2 NOT PRESENT ON 200V SINGLE PHASE AS/NZS & CE CONTROLS FUSE F3 NOT PRESENT ON 200V SINGLE PHASE CONTROLS

WARNING: ALL BLACK WIRES ARE AT POTENTIALLY LETHAL VOLTAGES. ALL 24VDC CONTROL WIRES ARE BLUE. - INDICATES OPPOSITE END OF WIRE

NOTICE: THE ABOVE WIRING DIAGRAMS ARE INTENDED TO BE USED AS A GUIDE ONLY. THE USER MUST REFER TO THE WIRING DIAGRAMS FOR THE SPECIFIC WIRING REQUIREMENTS FOR EACH MODEL AND APPLICATION.

INSTALLATION

Electrical *Continued*

575V Wiring Diagram – FasTrax/FasTrax LD

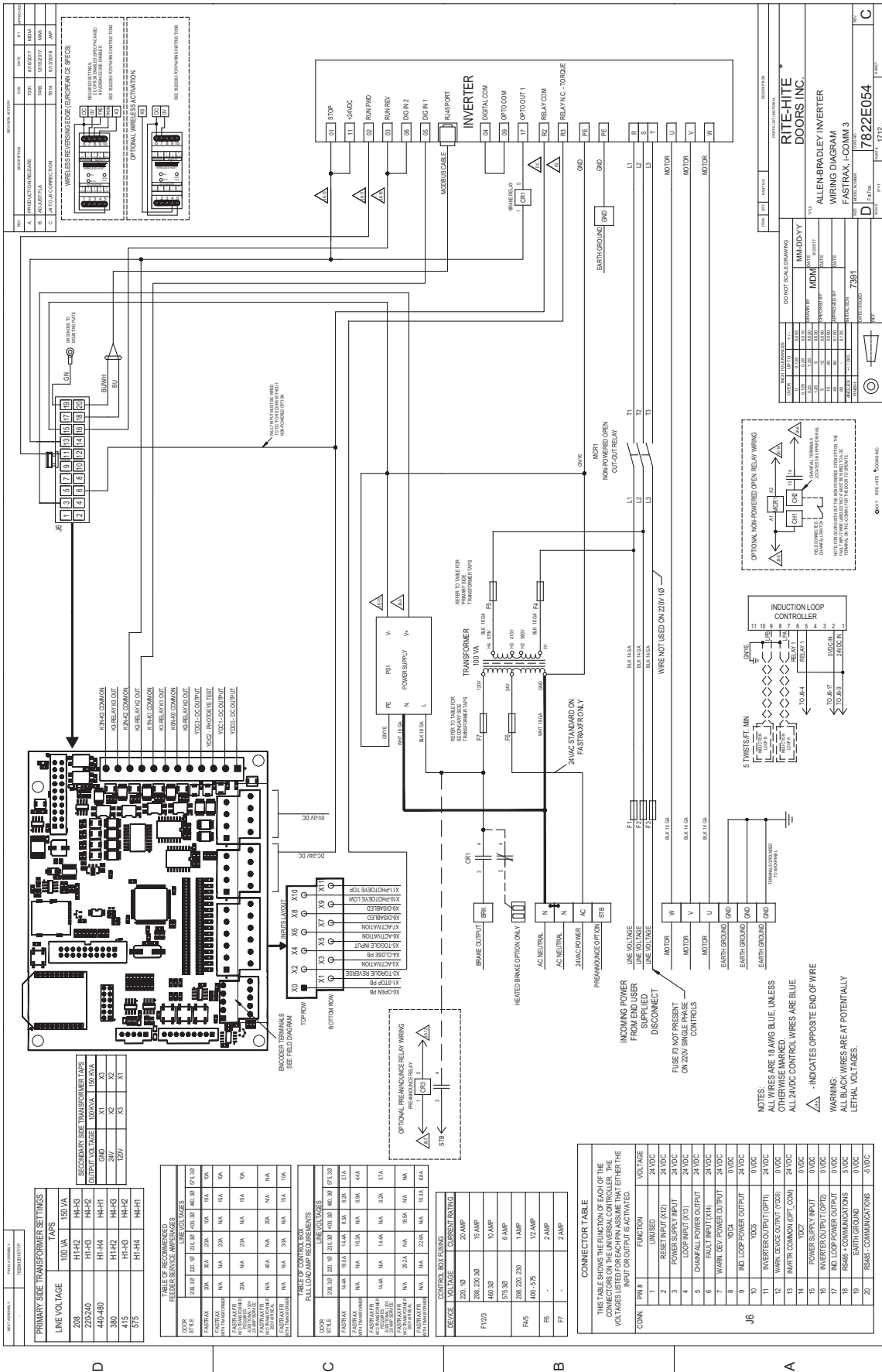

DO NOT SCALE DRAWING

DATE: 11/03/00
 DRAWN BY: MDM
 CHECKED BY: MDM
 DESIGNED BY: MDM
 PROJECT NO.: 7391
 REVISION: 1
 PART NO.: 7822E054
 SHEET: 1

OPTIONAL NON-POWERED OPEN RELAY WIRING

INDUCTION LOOP CONTROLLER

NOTES:
 ALL Wires are 18 AWG BLUE, UNLESS OTHERWISE SPECIFIED.
 ALL 24VDC CONTROL WIRES ARE BLUE.
 ALL BLACK WIRES ARE AT POTENTIALLY LETHAL VOLTAGES.

WARNINGS:
 ALL BLACK WIRES ARE AT POTENTIALLY LETHAL VOLTAGES.

CONNECTOR TABLE

THIS TABLE SHOWS THE FUNCTION OF EACH OF THE CONNECTORS LISTED FOR EACH PIN ASSUME THAT EITHER THE VOLTAGES LISTED FOR EACH PIN OR INPUT IS ACTIVATED.

CONN. PIN #	FUNCTION	VOLTAGE
1	UNUSED	24 VDC
2	RESET INPUT (R12)	24 VDC
3	POWER SUPPLY INPUT	24 VDC
4	LOOP INPUT (L03)	24 VDC
5	CHASSIS ALL POWER OUTPUT	24 VDC
6	CHASSIS ALL POWER INPUT	24 VDC
7	WARN SET POWER OUTPUT	24 VDC
8	IND. LOOP POWER OUTPUT	0 VDC
9	IND. LOOP POWER OUTPUT	24 VDC
10	IND. LOOP POWER OUTPUT	0 VDC
11	INVERTER OUTPUT (OPT1)	24 VDC
12	WARN DEVICE OUTPUT (Y03)	0 VDC
13	WARN R COMMON (OPT. COM)	24 VDC
14	WARN R COMMON (OPT. COM)	0 VDC
15	POWER SUPPLY INPUT	0 VDC
16	INVERTER OUTPUT (OPT2)	0 VDC
17	IND. LOOP POWER OUTPUT	0 VDC
18	IND. LOOP POWER OUTPUT	3 VDC
19	IND. LOOP POWER OUTPUT	0 VDC
20	RS485-COMMUNICATIONS	-5 VDC

INSTALLATION

Electrical *Continued*

575V Wiring Diagram – FasTrax FR/FasTrax FR LD

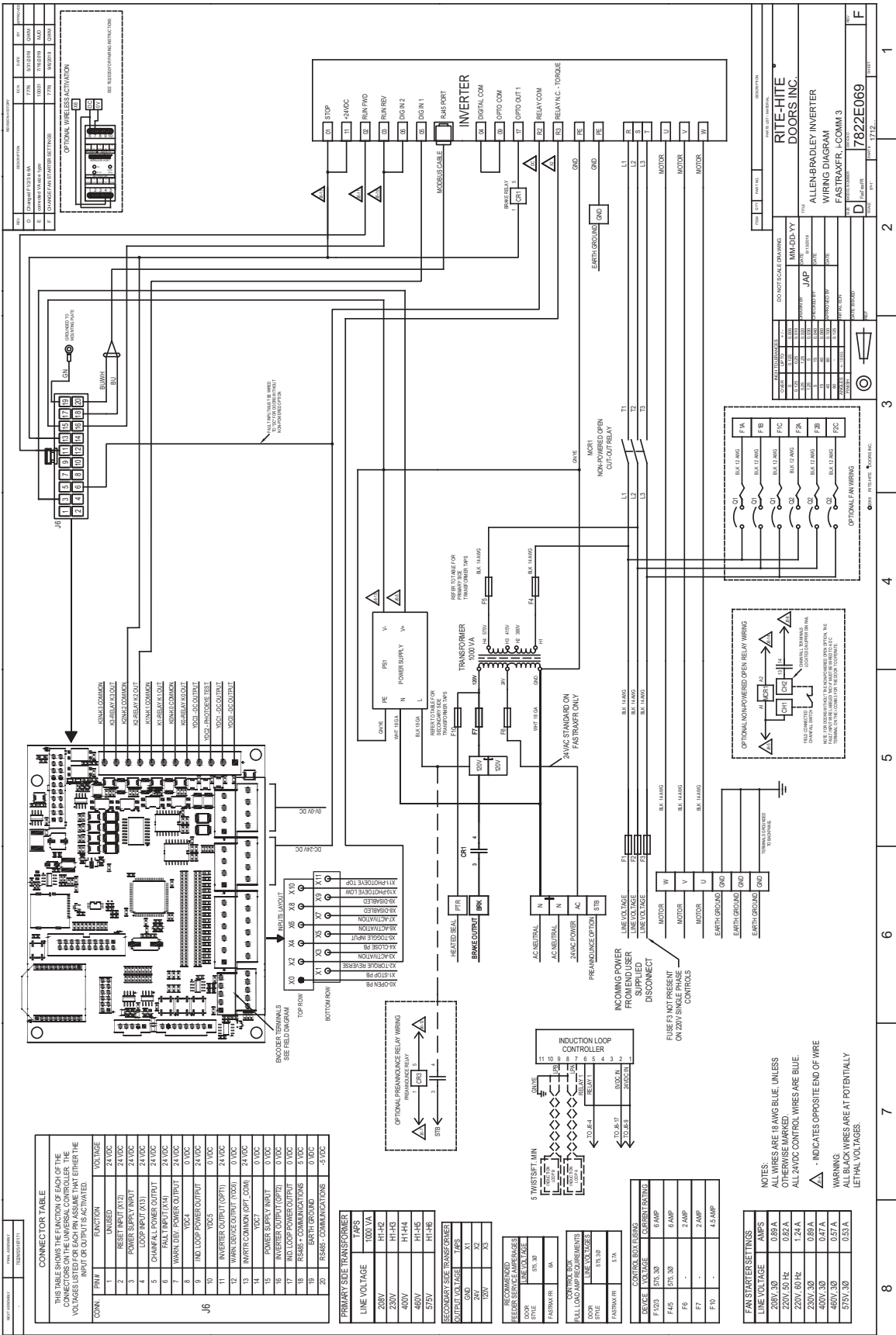

INSTALLATION

Electrical *Continued*

Electrical Cable Identification

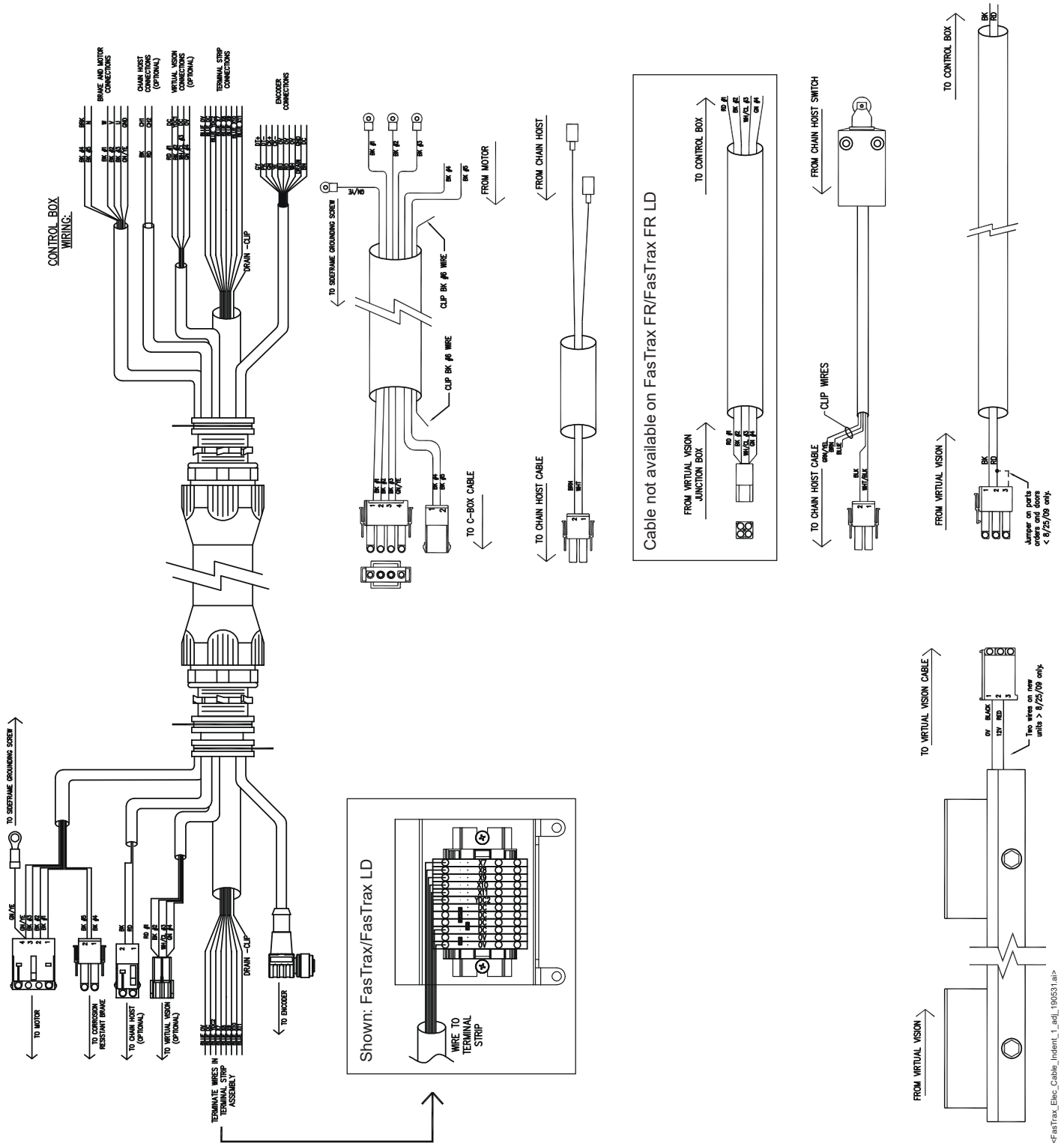

INSTALLATION

Doors Less than 8ft 0in [2438mm] D.O.H.

Guards – Non-Radial Door

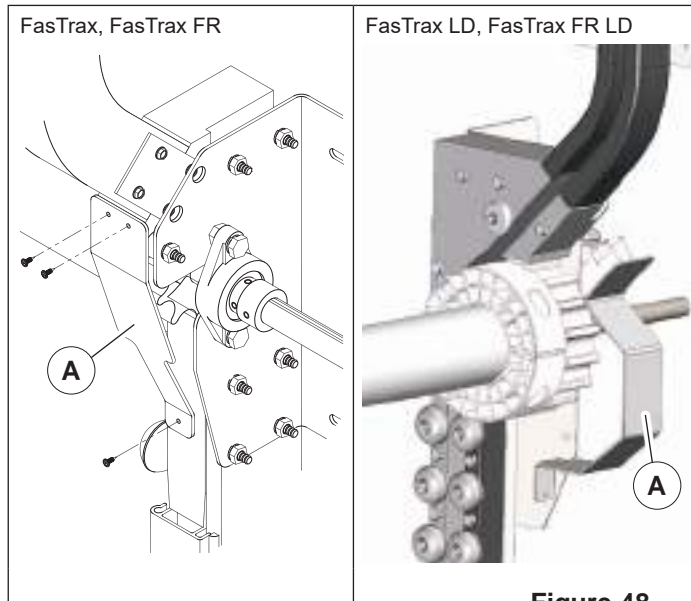

Install drive guard (A) onto vertical, tilt, or high lift style doors.

Guards – Radial Door

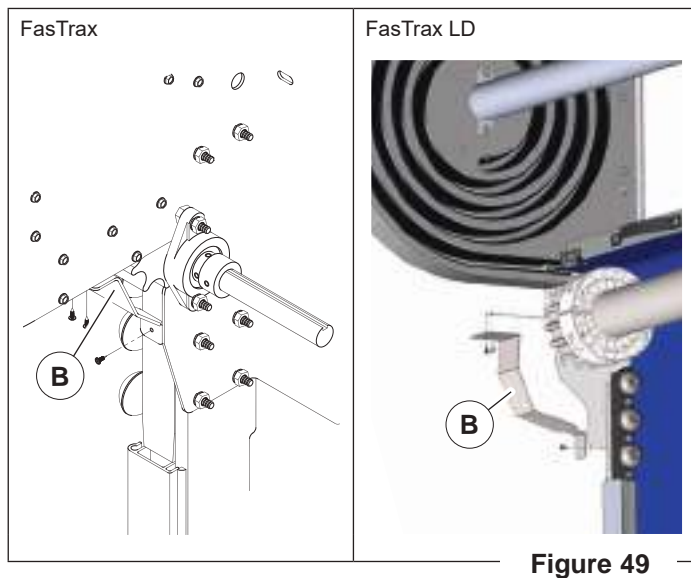

Install drive guard (B) onto radial style doors.

Keep Clear Sign

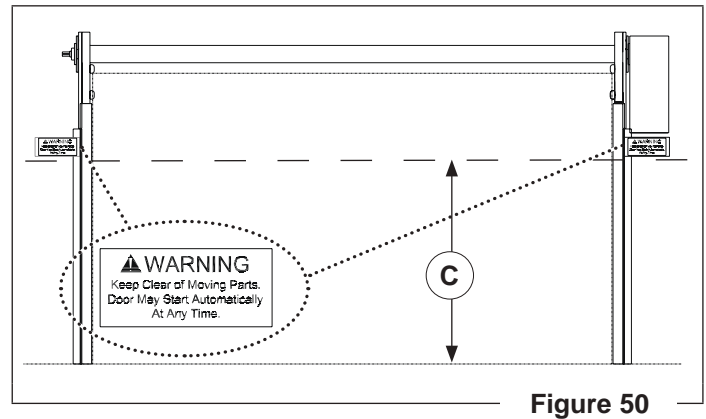

Install sign(s) onto lower tracks on each side, ≈ 5ft [1524mm] (C) from the floor.

INSTALLATION

Poly Lumber (FasTrax FR, FasTrax FR LD) (OPTIONAL)

NOTE: Maximum length piece is 10ft-6in [3200mm]. Several pieces may be required to meet proper length needed.

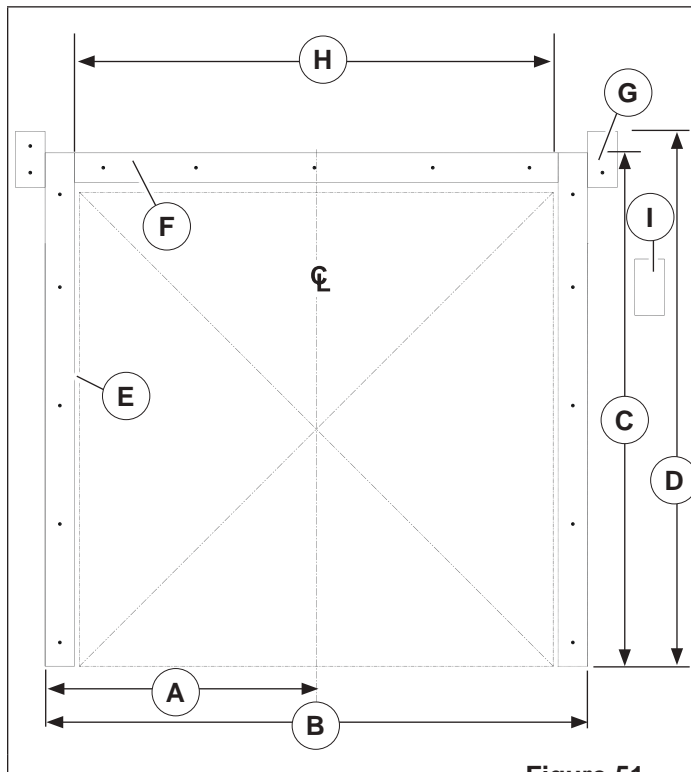

Figure 51

- Reference dimension (H):
FasTrax FR/FasTrax FR LD
 Ordered Door Width + 1/2in [12mm]
- Measure:
 - 1/2 Ordered Door Width + 8 3/4in [222mm]
 - Ordered Door Width + 17 1/2in [445mm]
 - FasTrax FR**
 Ordered Door Height + 8 3/4in [222mm]
FasTrax FR LD
 Ordered Door Height + 15 1/2in [394mm]
 - FasTrax FR**
 Ordered Door Height + 28 1/2in [724mm]
FasTrax FR LD
 Ordered Door Height + 15 1/2in [394mm]
- Caulk behind poly lumber piece(s) to install:
 - (vertical) and prevent air transfer.
 - (horizontal) lintel seal and lintel rollers
- Install short poly lumber piece(s) for:
 - Wall mount brackets
 - N.P.O.

INSTALLATION

Poly Lumber (FasTrax, FasTrax LD) (OPTIONAL)

NOTE: Maximum length piece is 10ft-6in [3200mm]. Several pieces may be required to meet proper length needed.

Radial

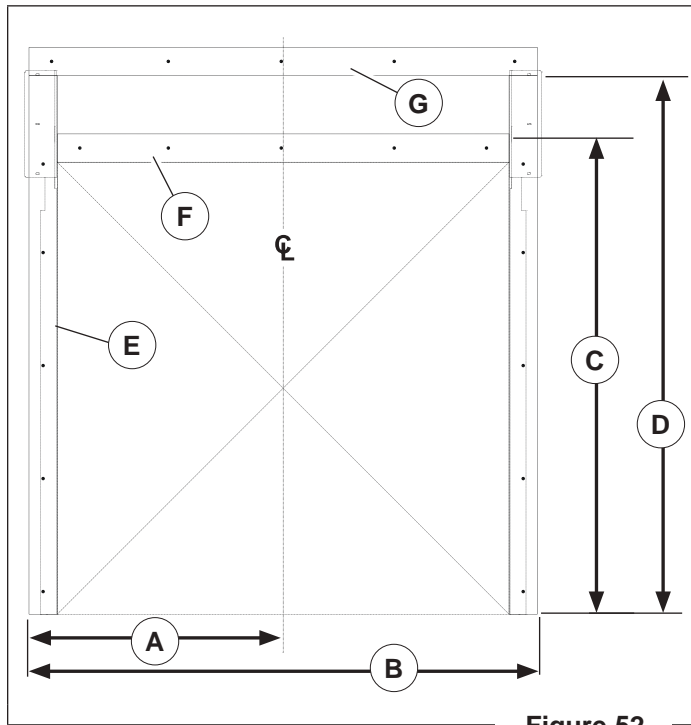

Figure 52

1. Measure:
 - (A) 1/2 Ordered Door Width + 8 1/2in [216mm]
 - (B) Ordered Door Width + 17in [432mm]
 - (C) Ordered Door Height + 8 1/2in [216mm]
 - (D) **FasTrax ≤ 10ft [3048mm]**
Ordered Door Height + 28 1/2in [724mm]
 - FasTrax > 10ft [3048mm]**
Ordered Door Height + 32 3/4in [832mm]
 - FasTrax LD**
Ordered Door Height + 35 1/4in [895mm]
2. Caulk behind poly lumber piece(s) to install:
 - (E) (vertical) and prevent air transfer
 - (F) (horizontal) lintel seal, lintel rollers
 - (G) center shroud

Non-Radial

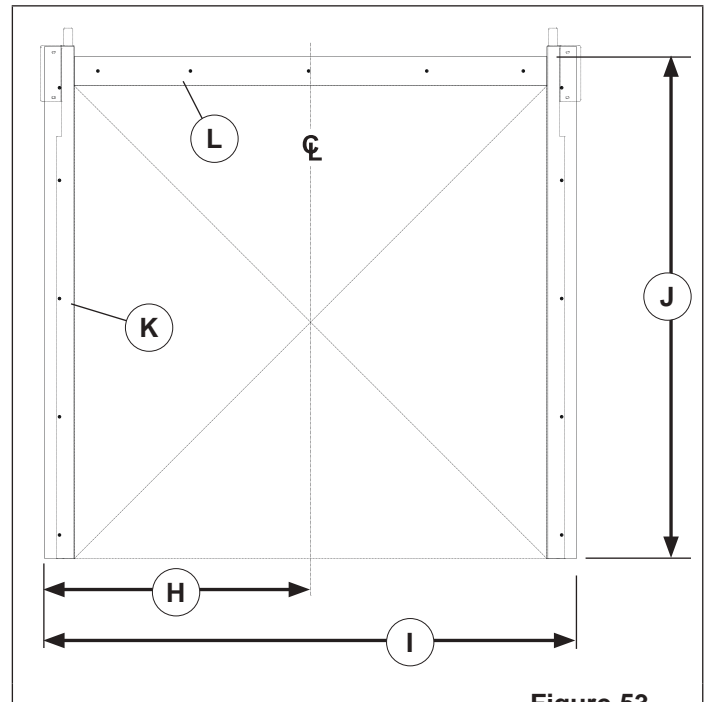

Figure 53

1. Measure:
 - (H) 1/2 Ordered Door Width + 8 1/2in [216mm]
 - (I) Ordered Door Width + 17in [432mm]
 - (J) **FasTrax**
Ordered Door Height + 10in [254mm]
 - FasTrax LD Non-Radial**
Ordered Door Height + 15 1/2in [394 mm]
2. Caulk behind poly lumber piece(s) to install:
 - (K) (vertical) and prevent air transfer
 - (L) (horizontal) lintel seal, lintel rollers

INSTALLATION

Radial Center Shroud (FasTrax, FasTrax LD)

(OPTIONAL)

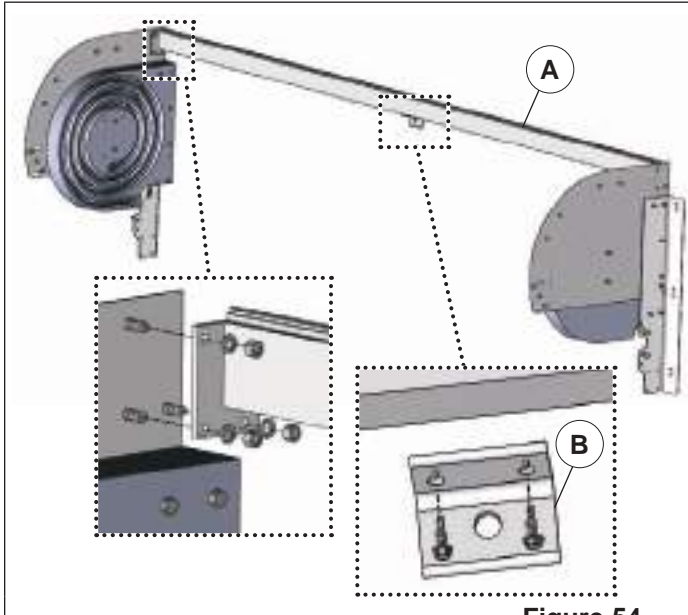

Figure 54

1. Locate components: 3 round aluminum shroud support tubes, 1 rectangular wall support tube, 1 aluminum trailer rail, fabric cover, 12 self drill/tap screws, (18) 3/8in [M10] hex nuts, flat washers and (18) 3/8in [10mm] lock washers.
2. Using 6 bolts, nuts, flat washers, and lock washers, fasten the rectangular shroud wall support (A) to the radial end plates. Install wall mount bracket (B) from the parts box in the best location available (recommended in the center of the opening) on rectangular shroud wall support (A).

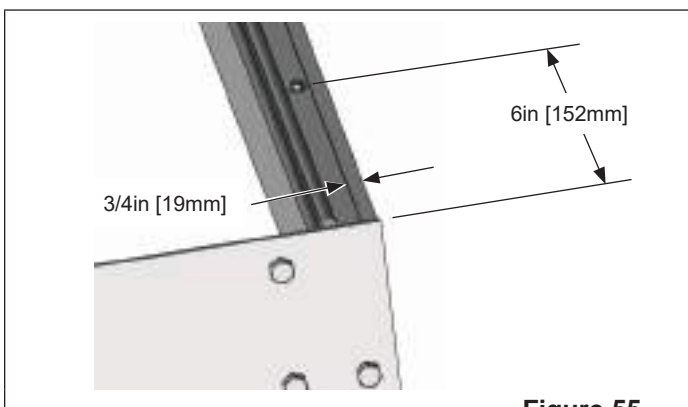

Figure 55

3. Install the fabric cover to the trailer rail. Attach the trailer rail to the wall support tube, flush to the back in the center and 3/4in [19mm] from the back on the ends. Screws will be attached in center, 6in [152mm] from each end. Leave no greater than 2ft [610mm] span between fasteners. The white part of the fabric cover sewn in rope will face down.

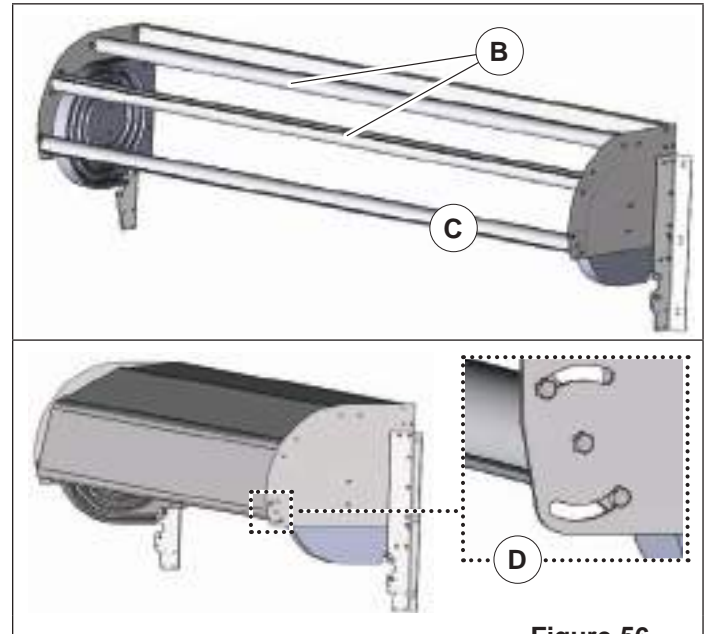

Figure 56

4. Fasten the 2 support tubes (B) to the radial end plates with 6 bolts, nuts and lock washers.
5. Install support tube end of shroud to the radial end plates (C). Drape the fabric cover over the 2 installed support tubes and hang free. Slide the fabric cover cord into the third support tube before installing. Line up and install 3/8in [M10] bolts through the remaining hole in the end plate and into the threaded hole in the center of the final support tube mounting plate, (only thread these in about 1/2in [M13]). Rotate the tube towards the wall as necessary and loosely install the remaining bolts, nuts, flat washers, and lock washers through the slots in the end plate and holes in the support tube.
6. Using a pry bar over the center hole bolt and under the top slot bolt (D), torque the tube until the cover is tight and tighten the lower fastener. Repeat for remaining bolts. Verify cover looks taut and tighten the 2 centering bolts.

INSTALLATION

Weld Plate (OPTIONAL)

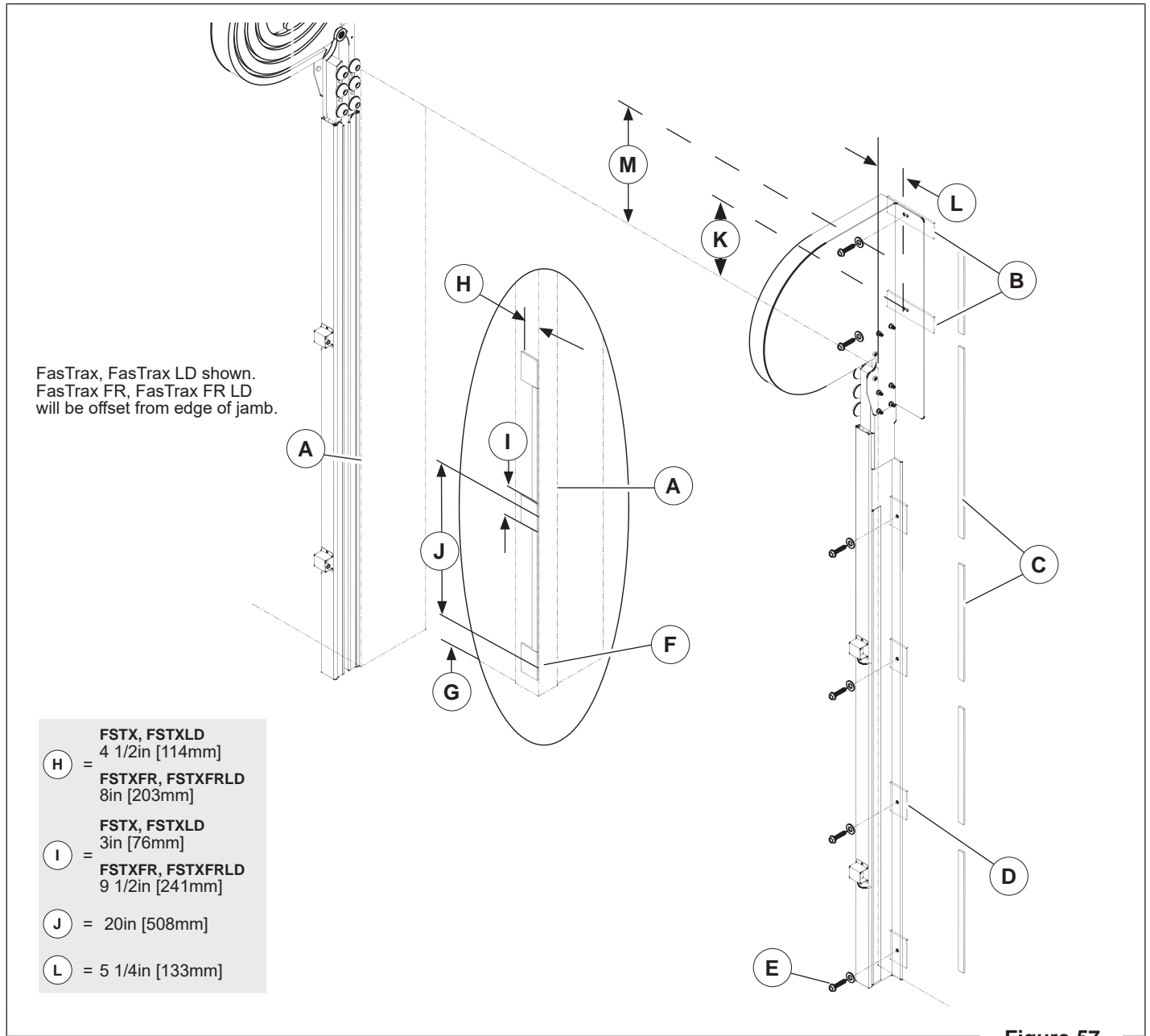

Figure 57

NOTE: Fastener required (at minimum) every other hole, ≈ 4ft [1219mm].

1. Measure from bottom of track to each hole location and position weld plates (B, D, F) on the steel jamb (A) at these locations and weld in place. If steel is not present at the track hole locations, weld where possible. Distance (G, M, K) varies based on O.D.H. and door configuration.
2. Position upper weld plates (B) so they catch the wall mount bracket holes. If no steel exists above the opening, it must be provided.
3. Fasten lower track to weld plates with self drill/tap screws and washers provided (E).
4. Fill gaps between weld plates with foam tape (C).

INSTALLATION

Wireless Activation (OPTIONAL)

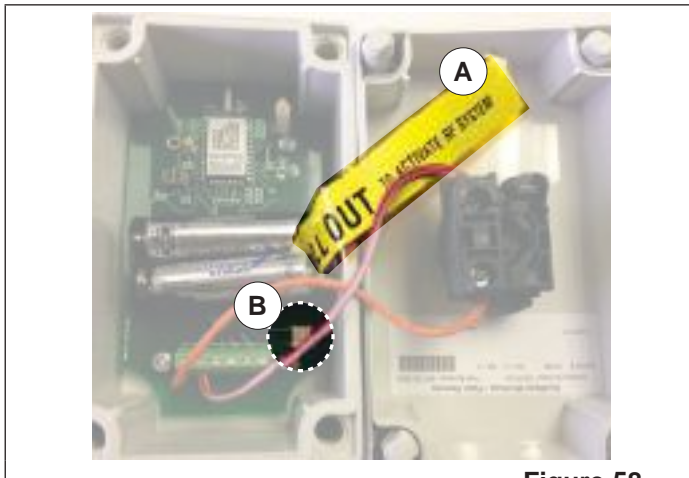

Figure 58

Pair the unit(s) at the control box prior to mounting.

To pair the host with a wireless device:

1. Apply power to the control box and wireless host unit.
2. Open the cover and remove the plastic strip (A) under the batteries in the remote unit to energize the device.
3. Press the "Pair" button (B) on the desired remote unit. An **AMBER** LED will begin to flash to indicate it is in the pairing mode.
4. On the wireless host, use a 1/8in [3mm] diameter rod made from a non-ferrous* material and insert into the "Remote Pairing" (C) hole approximately 1 1/2in [38mm] in depth until you feel a button depress and then release it. The "RF Com" LED (D) will begin to flash green once per second to indicate it is in pairing mode.
5. Once paired, the **RED** and **GREEN** LEDs will briefly turn on and then off. If the units are unable to *pair up*, the **GREEN** light will continue to flash for 20 seconds and then time out.
6. To test, activate the remote unit. The **GREEN** LED on the host and the **AMBER** LED on the remote should turn on and operate the door. If not, reattempt pairing process.
7. Mount the remote unit at it's operating position.
8. Wiring for host unit to Control Box i-COMM 3:
4 - X6 5 - DC 6 - DC 7 - OV

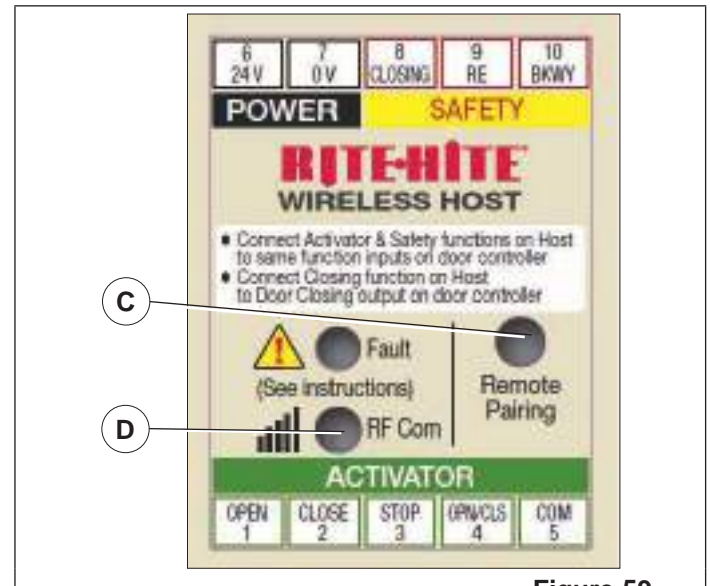

Figure 59

Resetting Communication Parameters

If the batteries are not lasting as long as they should, reset the communication parameters.

! WARNING/AVERTISSEMENT

Performing this operation will cause the host to clear all paired remotes. Remotes must be re-paired in order to re-establish communication.

Une fois cette opération effectuée, l'hôte efface toutes les télécommandes appariées. Appairer à nouveau les télécommandes pour rétablir la communication.

9. With power applied to the host, insert a thin screwdriver into the "Remote Pairing" slot. With the tip of the screwdriver pointing straight into the slot locate the "Remote Pairing" button.
10. Using the screwdriver, apply pressure to the "Remote Pairing" button. The **GREEN** LED will illuminate once the button has been pressed.
11. Keep pressure applied to the button for at least 5 seconds. The **GREEN** LED will turn OFF to signify the correct amount of time has elapsed.
12. Once the **GREEN** LED has turned OFF remove pressure from the button.
13. The **GREEN** LED will turn ON for 1 second to signify that the operation was performed successfully.
14. The host will now RESET, causing both the **RED** and the **GREEN** LED to briefly turn ON and then turn OFF.
15. The communication parameters have now been successfully RESET.

* If a metal object is used, caution should be taken to not contact the circuit board inside.

INSTALLATION

Labels/Shrouds

Label(s) – Back Side of Door

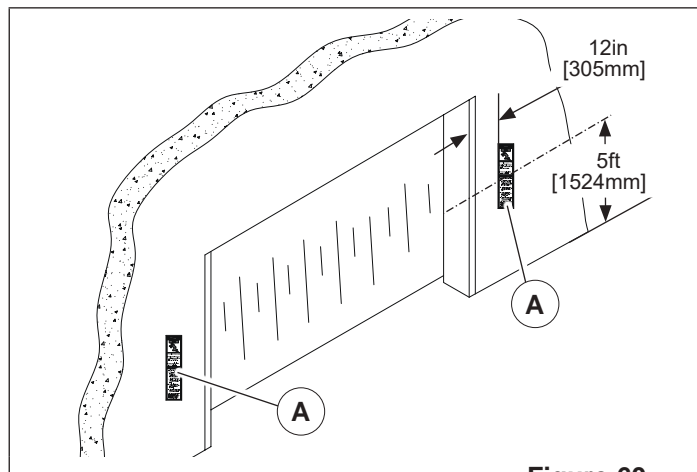

Figure 60

1. Clean surface where label(s) (A) will be placed.
2. Peel off backing on label and apply in position.

Drive Shroud

NOTE: DO NOT install until installation is complete.

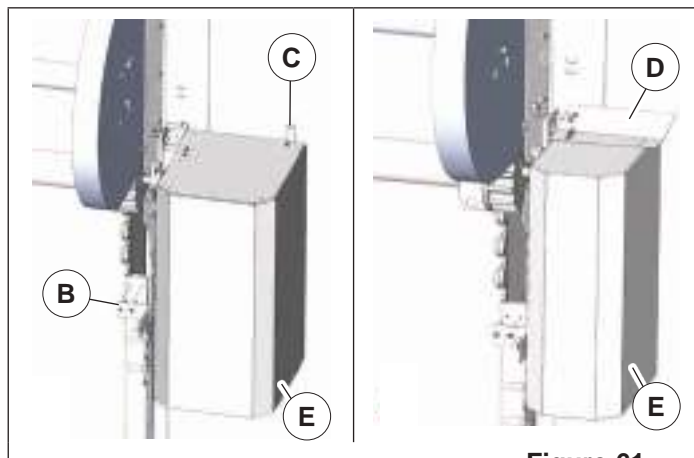

Figure 61

1. Attach lower (B) and upper (C) motor shroud brackets to lower track and header plates.
2. Align extension bracket (D) slots with holes in drive shroud and attach to upper mounting bracket with 2 thumb screws (exterior doors only).
3. Place drive shroud (E) into position and attach to lower mounting bracket with 2 thumb screws.

NOTE: Shrouds and upper mounting brackets are shipped assembled for the proper drive side doors. If needed, the shrouds are universal and can be switched in the field by removing the fasteners and reversing the assembly.

INSTALLATION

Final Checklist

#	DESCRIPTION	✓	N/A
1.	Control box conduit is mounted on the bottom.		
2.	Ground wires properly terminated to ground terminal		
3.	Shield wires properly terminated to ground terminal		
4.	Motor ground wire terminated to lower track ground screw		
5.	Encoder chain/sprockets/set screws properly aligned and tightened		
6.	Encoder cable tightened properly		
7.	Lower track properly spaced		
8.	Lower tracks caulked		
9.	Lower tracks square to wall		
10.	Lower tracks shimmed properly if jamb cap present		
11.	Wall mounting brackets securely fastened to wall		
12.	Photoeye wires properly secured to track or wall		
13.	Tracks/Radials lubricated		
14.	Track/Spreader bar in place		
15.	Upper track properly spaced		
16.	Upper track properly braced to wall		
17.	Drive tube level and evenly spaced (Set screws not in keyway slot)		
18.	Lintel roller(s) installed properly (FSTX, FSTXLD)		
19.	Proper mounting fasteners used		
20.	Motor terminal strip securely fastened to motor bracket		
21.	Security chain in place		
22.	Verify torque arm block mounting bolts are tightened (FSTXLD, FSTXFRLD)		
23.	Motor bumpers properly adjusted (FSTX, FSTXFR)		
24.	Drive shroud installed		
25.	Radial center shroud properly installed (FSTX, FSTXLD Radial)		
26.	N.P.O. properly installed (Optional)		
27.	If less than 8ft [2500mm] tall, make sure drive gear guards are in place		
28.	Poly lumber properly installed (Optional)		
29.	Perimeter seal is kink free, ice free and touching the floor (FSTXFR, FSTXFRLD)		
30.	Curtain fan(s) properly installed		
31.	"Verify Operation" page 69		
32.	Area clean of debris from installation		

2018-11-16

OPERATION

CAUTION/ATTENTION

Only travel through a doorway that is completely open.

Ne passer QUE lorsque la porte est complètement ouverte.

Forklift drivers should sound horn when approaching the door to alert others.

Les conducteurs de chariot élévateur doivent faire sonner le klaxon lorsqu'ils s'approchent de la porte pour alerter les autres.

Close, Stop, and Open

See "Figure 1" on page 6.

#	OPERATE DOOR:	PRESS BUTTON:
L	Close	Yellow
M	Stop	Red
N	Open/Reset	Green

Optional activation devices (e.g., motion/presence sensors, photoeyes, radio controls, pull cords, push buttons, and floor loops) can be used to open and close the door. Contact your local Rite-Hite representative for specific instructions based on your application.

Security

All parameters are protected by a PIN (Personal Identification Number). Login is required before changing any settings.

NOTE: Default PIN for the user is 3667. PIN can be changed (**Home ▶ Login ▶ Settings ▶ General ▶ Security ▶ User PIN**).

To Login, see "Figure 1" on page 6:

1. Press **Home** (Q)
2. Press **Login** (V)
3. Enter PIN
4. Press **Login**

The display will return to the main screen after successful login.

NOTE: The system will log you out automatically based on Logout Time specified (**Settings ▶ Timers ▶ Advanced ▶ Logout Timer**).

OPERATION

Common Locations (i-COMM 3)

LOCATION:	NAVIGATE TO:
Activation Wiring Help	Home ► Support ► Activation Help (choose screen)
Fault and Change History	Home ► Support ► Logs (choose screen)
Local Representative	Home ► Support ► Local Rep.
Troubleshooting Guides – Faults	Home ► Support ► Fault Help (choose screen)

Common Tasks (i-COMM 3)

TASK	NAVIGATE TO:		
Change PIN	Home ► Login ► Settings ► General ► Security ► User PIN		
Limit (Encoder) Set-up	Reset All Limits	Home ► Login ► Settings ► Limits ► Limit Set-up	Follow all on-screen prompts.
	Adjust Open Limit	Home ► Login ► Settings ► Limits ► Open Position Adj.	To adjust the limit so the door opens: <ul style="list-style-type: none"> • Farther, enter a positive value. • Less, enter a negative value.
	Adjust Close Limit	Home ► Login ► Settings ► Limits ► Close Position Adj.	To adjust the limit so the door closes: <ul style="list-style-type: none"> • Farther, enter a negative value. • Less, enter a positive value.
	Door Closing Timers	Home ► Login ► Settings ► Timers	Total open time is the sum of Close Timer and Pre-announce to Close Timers. or Total open time = Close Timer + Pre-announce to Close Timers.
Reset Maintenance	Home ► Login ► Settings ► General ► Reset Maintenance		
Network Set-up	Wired	Home ► Settings ► Set-up Wizards ► Network	
	Wireless	Home ► Settings ► Set-up Wizards ► Network Home ► Settings ► Set-up Wizards ► Wi-Fi	Install USB wireless module.

OPERATION

Verify Operation

Verify operation after initial installation and according to "[Planned Maintenance](#)" [page 70](#).

The door operations are controlled by a Universal Controller (i-COMM 3). The controller is set up and programmed during testing at the factory. Only Rite-Hite authorized service technicians should change the programming.

NOTE: Advise pedestrians to use man doors if present and not to lean into the door way.

1. To quickly determine if the door is ready to operate:
 - a. Open the control box.
 - b. Look at the row of (X) green Input LEDs on the i-COMM 3 and the label to verify proper state.
2. Check and remedy:
 - Pillow block bearing set screws tightened to 66 to 80in/lb [7.5Nm].
 - Wires are connected for the photoeyes.
 - All loose wires are secured away from moving parts.
3. With the power on, press the "OPEN" button, the door should open and close automatically after a short delay. To adjust the amount of door open time, the setting must be changed in the i-COMM 3 controller.
4. Operate and observe the door opening to make sure that it fully opens. Observe the closing action to make sure that the door operates smoothly, and fully closes without excessive curtain ripple. Black edging of curtain should not impact the floor.

If it is necessary to adjust Open or Close positions, refer to i-COMM 3 manual.
5. While the door is closing, block the reversing photoeyes. The door should reverse direction, move to the open position, and continue to operate.
6. Using end user material handling equipment:
 - Approach door slowly and verify that all the activation devices that are being used are operating properly. **DO NOT** attempt to drive through a door that is in a fault.
 - Use caution (honk horn) and look in all directions when approaching a door that is closing and make sure that the door will reverse before proceeding.

NOTE: A fault will occur if the optional non-powered chain hoist is operated. Press the green "OPEN/RESET" button to return to normal operation.

Photoeye Adjustment

DO NOT change the location of photoeyes (they are disabled before the curtain passes by). They **MUST** be at 18in [457mm] and 54in [1372mm].

Locate the receiver photoeye (A) on the drive side lower track. Located on the top of the photoeye are 2 LEDs.

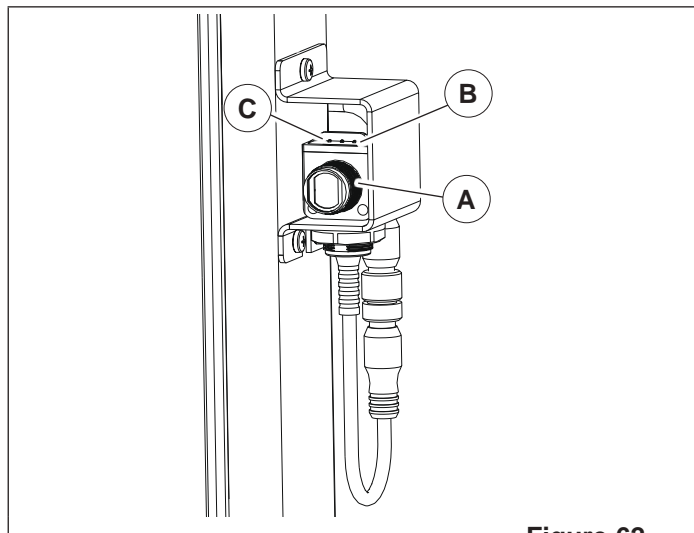

Figure 62

- The orange LED (B) will be on when the output is energized.
- If the green LED (C) is blinking, either the photoeye is out of alignment or the short circuit protection of the photoeye has been triggered.
- The green LED (C) indicates if the photoeye has power. The source photoeye on the non-drive lower track will only have the green LED for power.

Power Outage Procedure

See "[Power Outage Procedure](#)" on [page 39](#).

MAINTENANCE

Planned Maintenance

CUSTOMER:		SALES ORDER #:						SERIAL #:	DATE:
TASK	RECOMMENDED P.M. IN MONTHS							INSPECT AND PERFORM THE FOLLOWING:	
	1	6	12	18	24	30	36		
Verify Operation	✓	✓	✓	✓	✓	✓	✓	See "Verify Operation" page 69	
Curtain Fans (Optional)	-	✓	✓	-	✓	-	✓	Verify that curtain fans are powered and working. Make sure that the fans are positioned properly and are removing condensation from the curtain.	
Auto Re-Feed	-	✓	✓	-	✓	-	✓	Verify auto re-feed is operational.	
Brake	✓	-	✓	-	✓	-	✓	Verify that brake stops the door at open and closed positions as well as when stopped in the middle of travel. To move the curtain manually, pull the brake handle to the disengaged position. The curtain should be able to be moved manually. If brake is making noise, adjust.	
Controls/Wiring	-	-	✓	-	✓	-	✓	Clean and check all connections with disconnect off. Make sure all wires are free from moving parts.	
Curtain	-	✓	-	✓	✓	-	✓	Inspect for wear or damage; patch immediately to prevent condensation or frost buildup. Clean with warm soapy water. Check drive spheres; if missing or damaged, replace. Check top roller.	
Door Assembly	-	-	✓	-	✓	-	✓	Perform visual inspection for damage. Tighten all hardware. Replace any worn labels. Use air hose to remove dust and debris.	
Door Operation	-	-	✓	✓	✓	✓	✓	Operate door and make sure all operations are functioning properly.	
Drive Tube	-	-	✓	-	✓	-	✓	Verify drive tube gear is centered over track groove. Make sure bearing set screws and mounting bolts are tight.	
Gearbox	-	-	✓	-	✓	-	✓	Check gearbox fluid level; fill with Mobil - SHC 624 or Phillips 66 - Syncon 32 if low. Check lock collar set screws.	
Encoder/Chain/Sprockets	-	-	✓	-	✓	-	✓	Verify encoder chain and sprocket set screws are tight. Verify lock collar on encoder is tight. Check open and close positions; adjust as required. FSTXLD/FSTXFRD: Verify torque arm bolts are tight.	
Lintel Seal (not on FR)	-	-	✓	-	✓	-	✓	Verify lintel seal is sealing wall properly.	
Motor	-	-	✓	-	✓	-	✓	Check motor/gearbox bolts, torque to 71in-lbs [8Nm]. Check junction box to verify connections are tight.	
Non-Powered Opening (Optional)	-	-	✓	-	✓	-	✓	With power on, operate hand lever to verify chain hoist puts door into fault and opens door. Lubricate chain, sprockets, check set screws and alignment. Check spring and cable clamps.	
Photoeyes	-	-	✓	✓	✓	✓	✓	Verify both photoeyes reverse the curtain. The orange receiver LED should turn off when the beam is broken.	
Perimeter Seal (FR)	-	✓	✓	-	✓	-	✓	Free of tears and providing an adequate seal against curtain and the wall. If torn, patch immediately to prevent condensation build-up.	
Tracks/Radial (upper and lower)	✓	✓	✓	✓	✓	✓	✓	Perform visual inspection. Lubricate radials and tracks with food grade synthetic grease (Super Lube). It may be required to remove the existing grease prior to adding new. Verify proper width and tighten all hardware. Check foam seal if present.	
Track Retention Strips	-	-	✓	-	✓	-	✓	Inspect track retention strips; replace if cracked.	
Virtual Vision (Optional)	-	-	✓	✓	✓	✓	✓	Verify Virtual Vision is functioning properly. Red LEDs should be lit if movement on opposite side.	
Vision (not on FR)	-	✓	✓	-	✓	✓	-	Inspect vision for tears or separation. Clean with warm soapy water.	
Radial and Track Lubrication*	Lubrication of radials and tracks may be required more than every 6 months, based on usage and environmental conditions.							Lubrication of the radials and tracks is the sole responsibility of the end user. If door is mounted in a dirty environment, it may be required to remove the existing grease prior to adding new.	

*Use High-Temperature Synthetic Grease with PTFE (Polytetrafluoroethylene).

- The synthetic oil base in this food-grade silica-thickened grease increases the time before the next application.
- Contains a PTFE additive that reduces friction and waterproofs metal surfaces, preventing rust and corrosion.
- NSF rated H1 for applications with incidental food contact.
- Temperature range is -45° to +450°F [-45° to +232°C].
- Color is white.
- McMaster Carr # 1378K33 - 14.1oz cartridge.

MAINTENANCE

Encoder Replacement

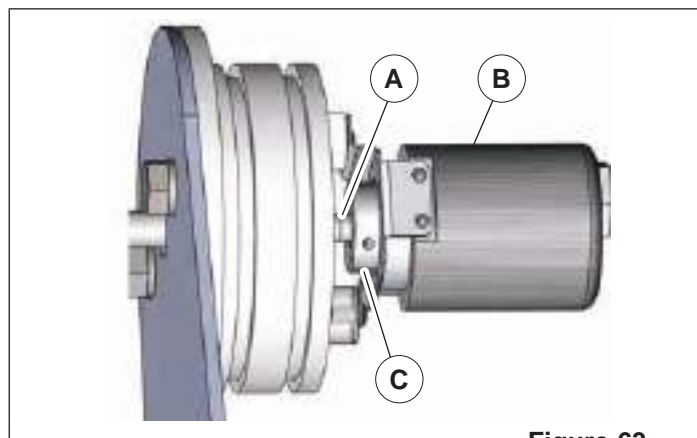

Figure 63

1. To replace encoder (B), unscrew connector.
2. Using 2mm Allen wrench, loosen lock collar (C) and slide encoder off of shaft (A).
3. Install new encoder, tighten lock collar (14in-lb. [1.5Nm]), line up notch and screw connector.
4. Proceed to **"Limit (Encoder) Set-up"** on page 68.

Drive Sphere Replacement

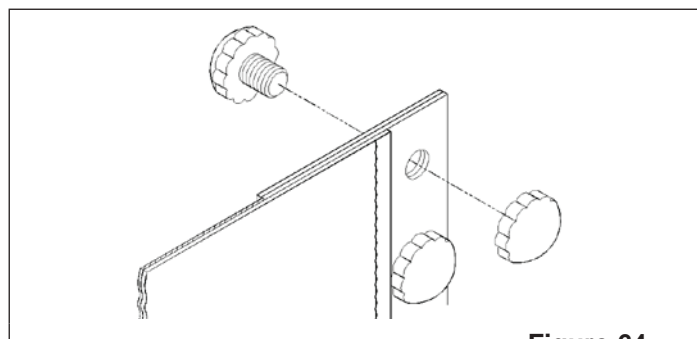

Figure 64

1. Apply adhesive* to curtain edge drive sphere stud before pushing through curtain and add more adhesive to stud before tightening. Adhesive must ooze out both sides after stud is tightened.
2. Stud must be tightened prior to adhesive starting to dry. Adhesive dry time is ≈ 1 minute.

Torque spec: 16in-lbs ± 4in-lbs [1.4Nm ± .45Nm].

*Recommended adhesive for thread locking and securing drive sphere to the edging:

Loctite® 438 or 3M-DP8005 (supplied by others).

Retention Strip Replacement

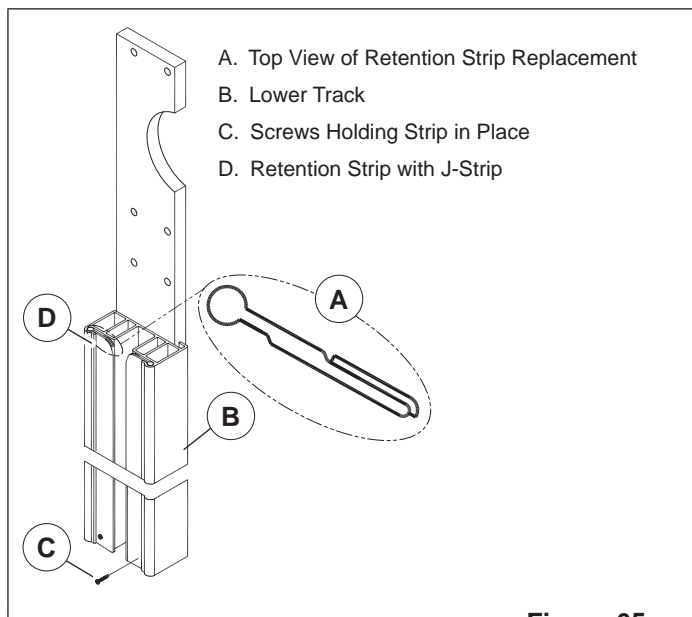

Figure 65

1. Turn power off and follow **"Lockout Procedure"** on page 4.
2. Remove lower re-feed roller.
3. Remove screws (C) holding retention strip in place and slide edging out through the top of the track (B). Use caution when pulling out so as not to catch on photoeyes.
4. Slide new retention strip into track, making sure not to catch on photoeyes. Align holes with photoeyes.
NOTE: Per the top view (A), orient the longer leg of the "J" toward the lower track and the groove away from the track.
5. Fasten strip with screws (C) at the bottom of track. **DO NOT** screw strip to lower track, other than at the bottom.

MAINTENANCE

Gearbox Oil

Drain Valve

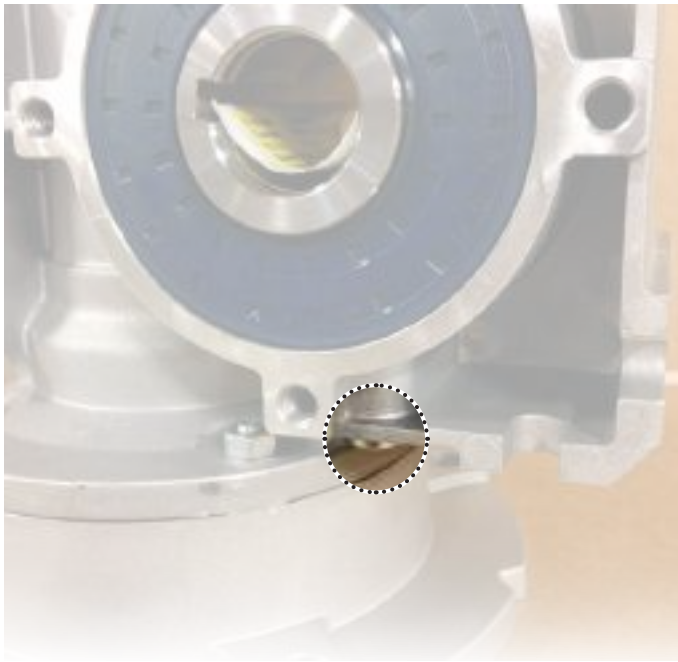

Fill Valve



Figure 66

This unit is designed to be maintenance free, completely sealed, and shipped factory filled with synthetic lube. The gearbox should not require additional lube.

If low, fill (3.2oz. capacity) with:
Mobil - SHC 624 or Phillips 66 - Syncon 32.

TROUBLESHOOTING

DEFINITION	FUNCTION
Activation	It is recommended not to wire activation devices until after the door is functioning properly.
Brake	The brake is powered by 105VDC which is converted from 110VAC. Brake will have \approx 267 ohms on normal readings, must disconnect from rectifier.
Breakaway	If the curtain is separated from the lower tracks, press the green Open/Reset button and the door will auto re-feed back into the tracks without tools or intervention. If a major separation occurs the drive tube may need to be turned manually to prevent damage to the curtain.
Control Box Cable	DO NOT drill holes on top of the control box to run conduit. Dust particles and moisture may cause damage to electrical components. The safest location for conduit is at the bottom of the control box. Failure to install conduit at the bottom of the control box may void the warranty. Supplied conduit cable is pre-wired. If it is too short, DO NOT splice wires, as the cable is shielded to prevent electrical noise. Make sure the motor is grounded and the braided (drain) wire is properly grounded to prevent electrical noise. Contact local Rite-Hite Representative for replacement.
Curtain	The curtain is driven by the drive spheres and the drive tube. a. If drive spheres are missing from curtain, repair or replace. b. If curtain struggles to raise or lower or is baggy, check for proper track spacing, FasTrax/LD: O.D.W. + 1/2in [12mm]. FasTrax FR/FasTrax FR LD: O.D.W. + 9in [229mm]. c. Check to make sure tracks are lubricated with food grade synthetic grease (Super Lube). d. If curtain is making contact with the wall when closing, verify lower tracks are not too close together.
Disconnect Switch	The disconnect switch is in line with fuse holder terminals F1, F2, F3, and removes power from the entire control box, except for incoming wires to bottom of disconnect.
Door does not close	a. Check status on i-COMM 3 display to see why door is staying open (" <i>Photoeye Blocked</i> " or " <i>Photoeye Failure</i> ", etc.). Display should read "Door Closing in "x" seconds". b. Verify proper incoming power is reaching inverter at L1, L2 and L3 (220, 230, 400, 460, 575). c. Verify chain hoist chain is not pulled and switch is not tripped, X14 MUST be on (See Non-Powered Opening). d. If run timer occurs, check for binding or obstructions. Tracks may need to be lubricated to reduce friction. e. Verify inputs X3, X5, X6 or X7 are not on. If on, remove wire from terminal to determine what is keeping light on. f. Verify outputs K1, K2, K4, K5 and YDC2 are on or coming on to signal inverter to close door. g. Verify X10 and X11 are on and that the photoeyes are lined up and not blocked. h. Verify as the curtain gets near the photoeyes that they are being shut off. i. If curtain reverses at photoeyes, verify that the photoeye wiring is not reversed, X11 is upper (54in [1372mm]), X10 is lower (18in [457mm]). j. Verify inverter display is changing frequency. k. Verify encoder has been set up. l. Verify rectifier has 120VAC going to it and \sim 105VDC coming out to the brake.
Door does not open	a. Verify input X3, X5, or X6 are coming on when activation device is being used. b. Verify outputs K3, K4, K5 and YDC2 are on or coming on to signal inverter to open door. c. Check status on i-COMM 3 display to see why door is staying closed. Display should read "Door Opening". d. Verify inverter display is changing frequency. e. Verify proper incoming power is reaching inverter at L1, L2 and L3. f. Verify chain hoist chain is not pulled and switch is not tripped, X14 MUST be on (See Non-Powered Opening).
Door slams open/close	a. Verify the open and close positions are properly set. b. Verify encoder lock collar and sprocket set screws are tight and the chain moves when the drive tube is turning. c. Verify the encoder shaft turns when the drive tube is turned. d. Verify the inverter is changing speeds on the display. e. Verify the phasing is correct. The door should open when the green Open button is pressed. f. Verify the brake is engaged and not released. g. Verify the key been installed on the gearbox shaft. h. Verify the proper ratio gearbox is being used. i. Verify encoder has been set up. j. Verify rectifier has 120VAC going to it and \sim 105VDC coming out to the brake.
Drain Wire	Verify that drain wire is terminated properly. Failure to properly terminate the drain wire may result in sporadic reversals, photoeye, and other issues due to either static electricity or electrical noise and void warranty.
Drive Side Switch	The drive can be switched from right hand to left hand by performing the following: a. Remove and switch conduit mounting bracket to opposite side. b. Remove and switch torque arm bracket. c. Remove and switch drive and non-drive photoeyes and cables. d. Flip drive tube 180°. e. Reverse drive shroud assembly. f. Set up i-COMM 3 to state the proper right or left hand drive.
Drive Tube	If drive spheres make excessive clicking noise, make sure tube drive gears are centered over track grooves.
Encoder	See pages 32, 34 . DO NOT splice or extend the encoder cable. a. If curtain is not stopping at the same position, make sure encoder cable is grounded. b. Verify encoder chain is operating properly and sprocket set screws are tight to shafts. c. See on-screen help on touchscreen.

TROUBLESHOOTING

DEFINITION	FUNCTION
Fuses	F1, F2, F3: Incoming power fuses, must have line voltage across all 3 legs (transformer, inverter, motor). F4, F5: Primary side transformer fuses, must have line voltage across both legs. F6, F7: Secondary side transformer fuses, F6 is 24VAC (FR/FR LD - heated pull cord) and F7 is 120V (power supply and brake).
i-COMM™ 3 Controller	The i-COMM 3 controller is a circuit board that controls the actions of the door. There is a digital display that shows the cycles, status and position of the door at any time during its travel. For input and output function signals, refer to i-COMM 3 IO label inside of control box. Settings can be changed for re-close or pre-announce timers, interlocks, special activation commands, among others. Refer to instructional manual included. a. Verify i-COMM 3 is receiving 24VDC from power supply. b. If i-COMM 3 display is blank or hard to see, adjust contrast. c. Input X10 - Lower photoeye will be on unless photoeye is blocked, not aligned or mis-wired. d. Input X11 - Upper photoeye will be on unless photoeye is blocked, not aligned or mis-wired. e. Input X14 - Fault needs to be on for the door to operate (chain hoist). f. The door can be set to close from 2 to 255 seconds. Follow i-COMM 3 adjustment instructions.
Interlock	To disable interlock, change input setting from 0 - Interlock to disable.
Inverter	See on-screen help on touchscreen for proper parameter settings.
LEDs	Refer to i-COMM 3 manual for functions or input/output values.
MCR1 (contactor)	If the MCR1 (contactor) does not stay energized, verify the chain hoist switch is closed. If the chain hoist has been activated, it will break the circuit. Check continuity from CH1 to CH2.
Motor	If door will not run when given an activation, check the following: a. Check voltage to inverter. b. Check voltage and for loose wires at terminals, U, V, and W. c. 208V-240V motor will have 2.8 ohms on normal readings. d. 400V-480V motor will have 9-10 ohms on normal readings. e. 575V motor will have 13 ohms on normal readings.
Motor Phasing	If Open/Reset button is pressed and the door closes, phasing is reversed; switch wires in terminals, V and W. Make sure the motor is properly grounded to prevent electrical noise.
Non-Powered Opening (N.P.O.)	If issues arise with the non-powered opening chain hoist, check the following: a. In the event of a power outage, operate hand lever and hand chain to open or close door. b. If hand lever is pulled while door is powered, the door will go into fault mode (green light flashing), no X14. Reset door by pressing the green flashing button. c. If door will not move when hand lever is pulled, verify engagement pins are engaged. Verify brake is being released and that cable and spring are working properly.
Open/Reset Push Button	The Open/Reset push button function is when the button is pressed, a command to open the door is given. To jog door when i-COMM 3 states "Photoeye Failure", press and hold the Open/Reset button.
Photoeyes	The photoeyes are wired to the 24VDC circuit and are wired as normally closed when there is power to the unit and the emitter photoeye is aligned with the receiver photoeye. There are 3 lights on the receiver and 1 on the emitter. Green is for power, orange is for proper alignment. The photoeyes will reverse or hold the door open when the photoeye beam is blocked. When the beam is not broken, the door will auto-reclose. If photoeyes require adjustment, check that lower tracks are square to the wall. a. Power to Brown (DC) and Blue (OV) wires. b. Internal photoeye relay (wires Black/Blue) should be closed when photoeye is aligned and open when not aligned. c. When open, i-COMM 3 verifies photoeye inputs are off. If on, door will fault. If off, test is ok and emitters turn on. d. Orange light on the Receiver should be on when aligned. e. Green light on the Emitter indicates the unit is powered up. f. Input X11 will go off when the upper 54in [1372mm] photoeye is tripped. g. Input X10 will go off when the lower 18in [457mm] photoeye is tripped. h. If 2 or more doors are back to back, verify they are not reading each other. A plate may be required to separate. i. On doors < 43in [1092mm] O.D.H., the 54in [1372mm] photoeye is omitted. j. On doors > 68in [1727mm] O.D.H., but < 43in [1092mm] O.D.H., the 54in [1372mm] photoeye is lowered to 35in [889mm].
Power Supply	Power Supply is powered by 120VAC from the F7 fuse and delivers 24VDC to the i-COMM 3.
Pressure	If the curtain is blowing out because of high wind or negative pressure, check the following: a. Tracks MUST be mounted at FasTrax/FasTrax LD: O.D.W. + 1/2in [12mm]. FasTrax FR/FasTrax FR LD: O.D.W. + 9in [229mm]. If mounted wider, excessive curtain wear may occur. If too narrow, curtain buckling or billowing will be greater. b. Verify the curtain has all the drive spheres in place. c. Verify Lexan Strips are present and functioning properly.

TROUBLESHOOTING

DEFINITION	FUNCTION
Tracks	a. Verify tracks are properly spaced. MUST be FasTrax/FasTrax LD: O.D.W. + 1/2in [12mm]. FasTrax FR/FasTrax FR LD: O.D.W. + 9in [229mm]. b. Lubricate as required per Maintenance Schedule, page 70 .
Virtual Vision (Optional)	When motion is sensed via Falcon motion sensors, the Virtual Vision red LEDs will illuminate to notify driver of movement on the opposite side of the curtain. It is normal for the YDC1 output to flash on i-COMM 3 during door operation.
Voltage Change	To change the voltage: <ol style="list-style-type: none"> Change transformer taps and fuses per electrical diagram. Change motor wiring per junction box diagram. Replace Inverter with proper voltage. Resistor to proper voltage. Change voltage selection on i-COMM 3.

PARTS

Control Box (FSTX/FSTXLD)

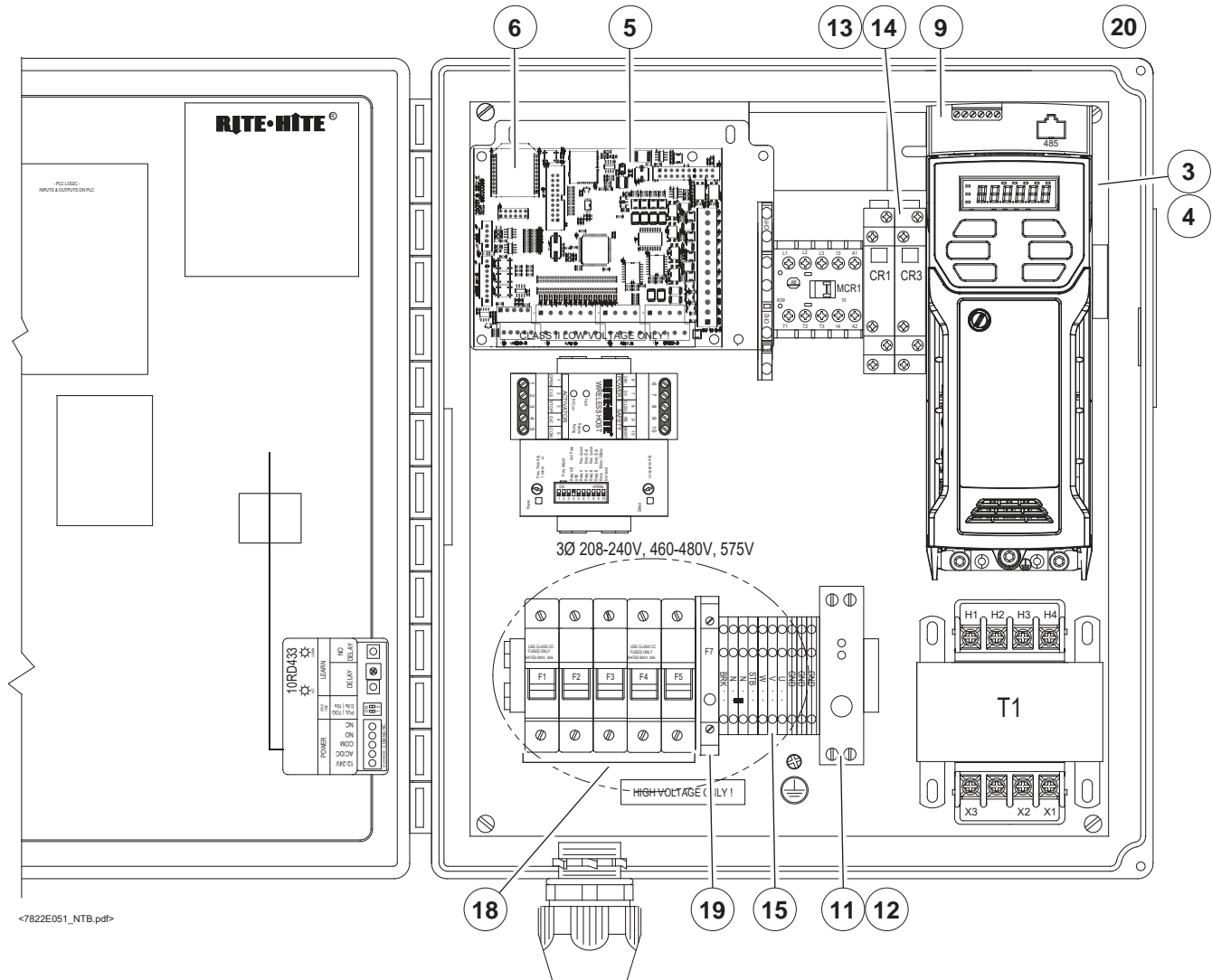

<-7822E051_NTb.pdf>

#	DESCRIPTION	PART #
3	Kit, Inverter, 2HP, 230V, 1-3PH, M200	53701041
4	Kit, Inverter, 2HP, 460V, 1-3PH, M200	53701042
5	Kit, Controller, i-COMM 3, Replacement	53701043
6	Kit, Wireless Interlock Radio	2104
9	Adapter, RS-485, M Series	10300019
11	Power Supply, 24VDC, 30W	65700007
12	Power Supply, 24VDC, 60W	65700012
13	Relay, SPDT, 10Amp, 24VDC	66450014
14	Relay Socket, Single Pole, 10 Amp 250V	70350002
15	Terminal, PX, Cage, 24A, 3-Hole	73100096

#	DESCRIPTION	PART #
See fuse table on control box cover:		
18	FUSE, 10AMP, 600V, CC, KLDR	51000033
	FUSE, 4.5A, 600V, CC, KLDR	51000046
	FUSE, 6A, 600V, CC, KLDR	51000055
	FUSE, 20AMP, 600V, CC, KLDR	51950077
	FUSE, 25AMP, 600V, CCMR	51000052
19	FUSE, 2AMP, 250V, TIME DELAY	51000005
20	Control Box Assembly, FSTX/FSTXLD, i-COMM 3	1712
21*	Harness, Wire Kit, FSTX/FSTXLD	52000072

*Not Shown

PARTS

Control Box (FSTXFR/FSTXFRLD)

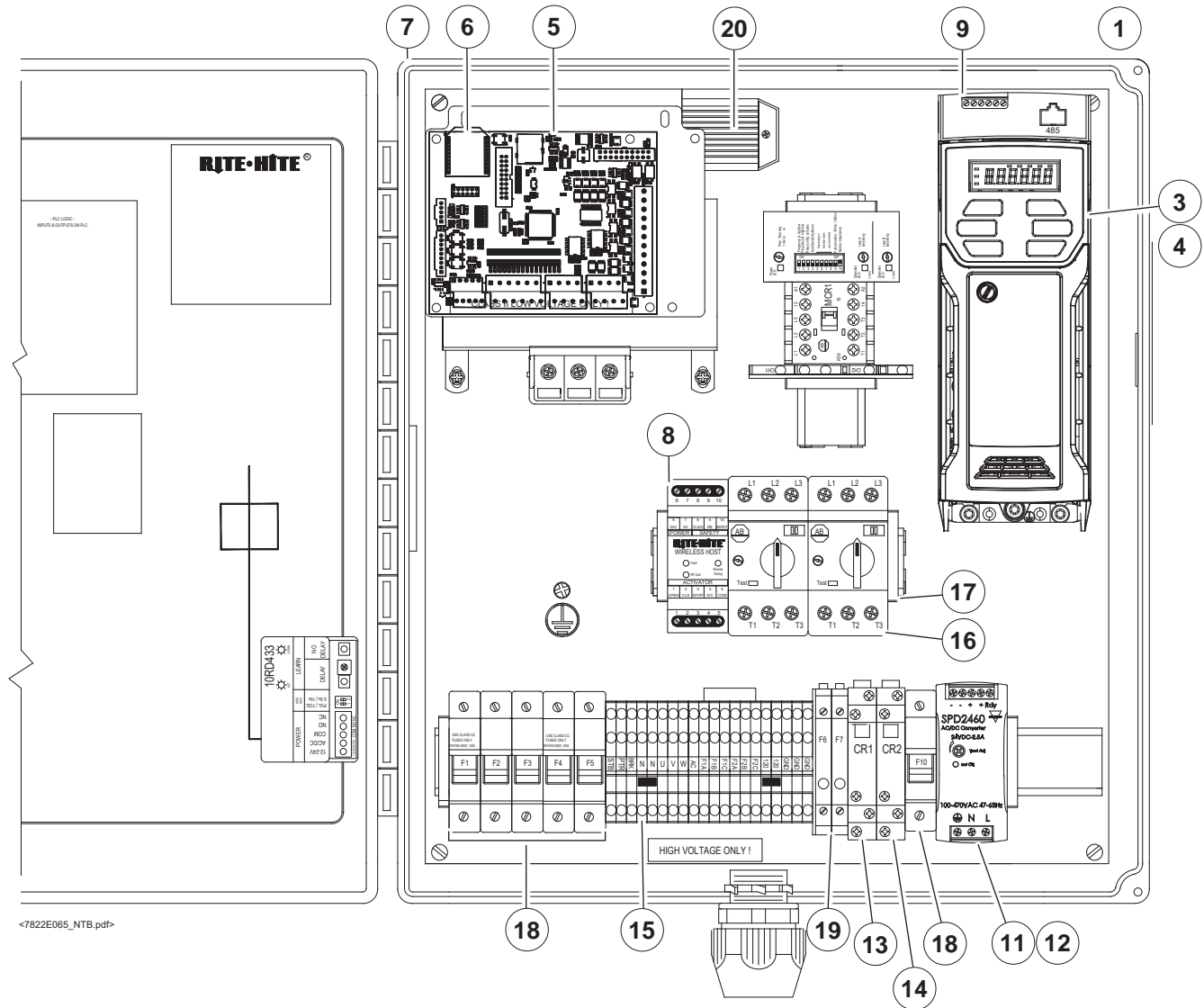

<7822E065 NTB.pdf>

#	DESCRIPTION	PART #
1	Control Box Assembly, FSTXFR, i-COMM 3	1718
2*	Harness, Wire Kit, FSTXFR	52000077
3	Kit, Inverter, 2HP, 230V, 1-3PH, M200	53701041
4	Kit, Inverter, 2HP, 460V, 1-3PH, M200	53701042
5	Kit, Controller, i-COMM 3, Replacement	53701043
6	Kit, Wireless Interlock Radio	2104
7	Enclosure, Mounting Foot	51950018
8	Controller, Wireless Act, BTR, 12-24V	17500025
9	Adapter, RS-485, M Series	10300019
10*	Cable, Inverter, 24/4 UTP	15650290
11	Power Supply, 24VDC, 30W	65700007
12	Power Supply, 24VDC, 60W	65700012
13	Relay, SPDT, 10Amp, 24VDC	66450014
14	Relay Socket, Single Pole, 10 Amp 250V	70350002
15	Terminal, PX, Cage, 24A, 3-Hole	73100096

#	DESCRIPTION	PART #
16	Starter, Motor, 1.6-2.5A	51950087
	Starter, Motor, 1.0-1.6A	51950110
	Starter, Motor, 0.4-0.63A	51950030
17	Din Rail, Elevated, 5.5"	38120036
See fuse table on control box cover:		
18	FUSE, 10AMP, 600V, CC, KLDR	51000033
	FUSE, 4.5A, 600V, CC, KLDR	51000046
	FUSE, 6A, 600V, CC, KLDR	51000055
	FUSE, 20AMP, 600V, CC, KLDR	51950077
	FUSE, 25AMP, 600V, CCMR	51000052
19	FUSE, 2AMP, 250V, TIME DELAY	51000005
20	KIT, RESISTOR, INV, 75OHM, 230V	53701088
	KIT, RESISTOR, INV, 350OHM, 460V	53701089

*Not Shown

PARTS

Virtual Vision/Curtain Fan Junction Box

FasTrax, FasTrax LD

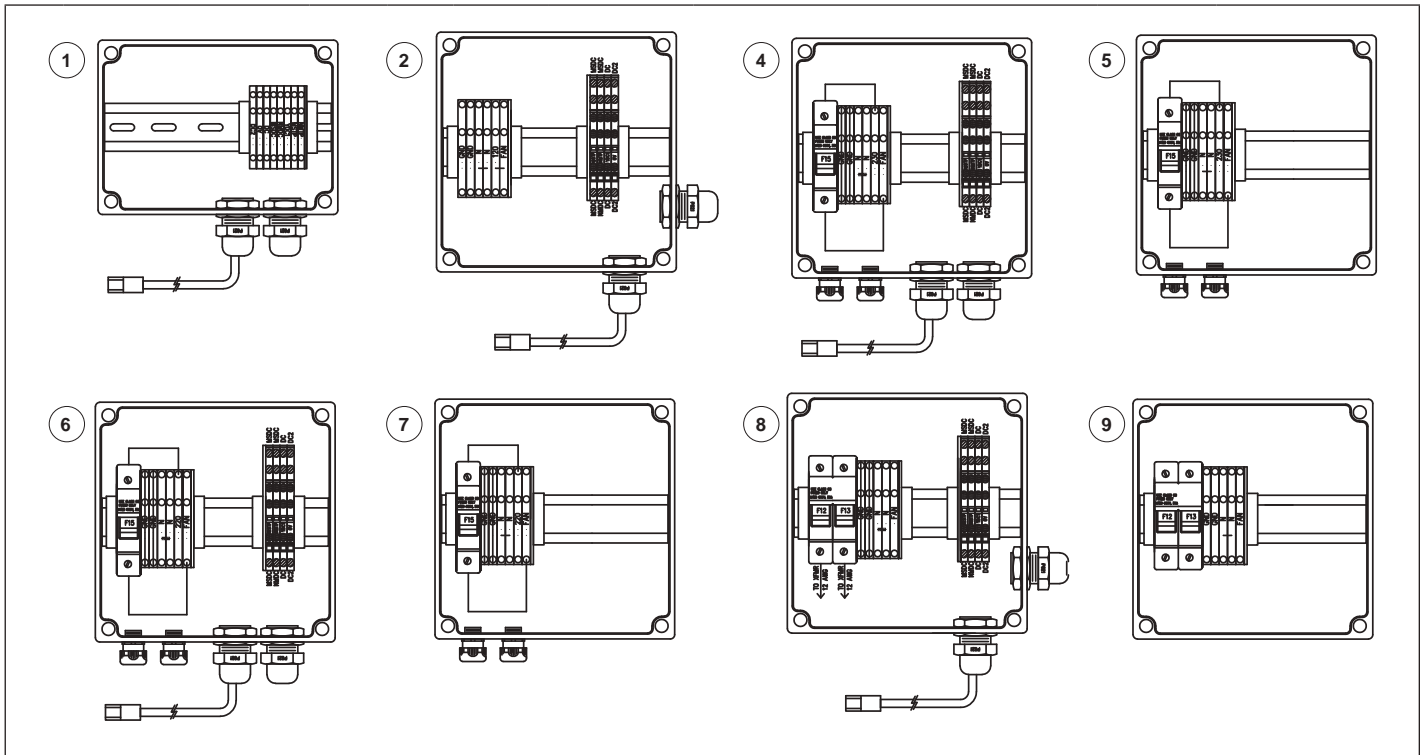

#	VIRTUAL VISION	CURTAIN FANS	120V	230V	220V, 400V	STEPDOWN	DESCRIPTION	PART #	TRANSFORMER PART #
						460V, 575V			
1	✓	–	–	–	–	–	JBOX,VIRTUAL VISION	53530013	–
2	✓	✓	✓	–	–	–	JBOX,FANS,120V,VRTLV	53530023	–
3	–	✓	✓	–	–	–	NO JBOX REQUIRED	–	–
4	✓	✓	–	✓	–	–	JBOX,FANS,230V,VRTLV	53530025	–
5	–	✓	–	✓	–	–	JBOX,FANS,230V	53530024	–
6	✓	✓	–	–	✓	–	JBOX,FANS,220V,VRTLV	53530027	–
7	–	✓	–	–	✓	–	JBOX,FANS,220V	53530026	–
8	✓	✓	–	–	–	✓	JBOX,FANS,460/575V,XFMR,VRTLV	53530029	if 575V:73550017 else : 73550024
9	–	✓	–	–	–	✓	JBOX,FANS,460/575V,XFMR	53530028	if 575V:73550017 else : 73550024

NOTE: The Junction box kits do not include the related step down transformers. If a transformer is required, Kit and Transformer part numbers are needed.

PARTS

Miscellaneous

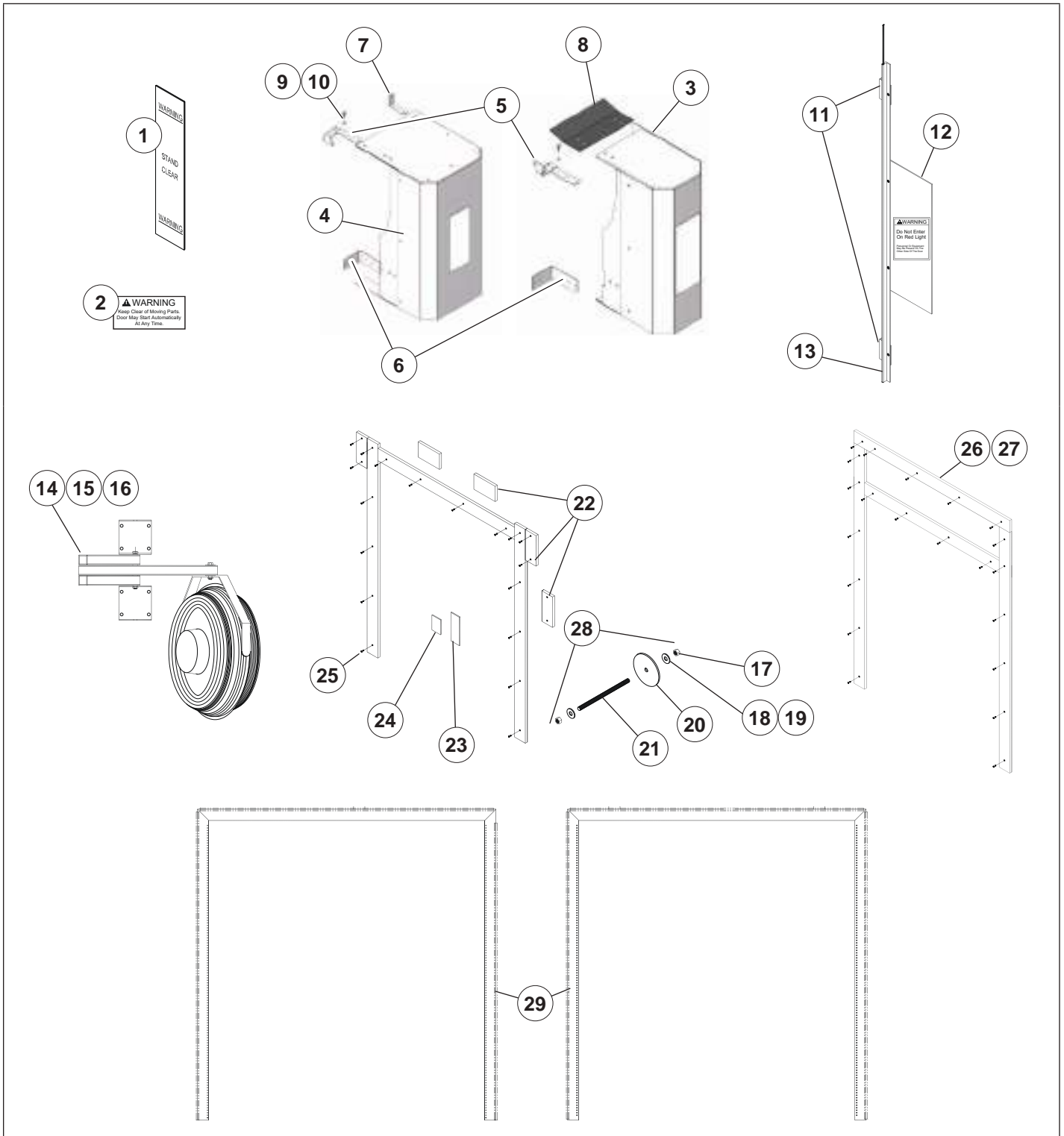

PARTS

Miscellaneous *Continued*

#	QTY	DESCRIPTION	PART #
*	1	FasTrax Door (Complete)	FSTX, FSTXFR, FSTXLD, FSTXFRLD
*	1	Kit, FasTrax Service Parts, US, Encoder	53700804
1	2	Label, Warning, Stand Clear, 2in x 9in, (Doors <8ft-0in [2438mm] H)	53850516
2	1	Keep Clear Warning Label (Doors <8ft-0in [2438mm] H)	53850534
	1	Sign Plate (Doors <8ft-0in [2438mm] H w/o Shroud)	65000609
3	1	Kit, FSTX, Shroud, Motor, RH	53701007
	1	Kit, FSTX, Shroud, Motor, LH	53701013
4	1	Kit, FSTX, Shroud, Motor, N.P.O., RH	53701008
	1	Kit, FSTX, Shroud, Motor, N.P.O., LH	53701014
5	1	Kit, FSTX, Shroud, Motor, Bracket, Upper	53701009
6	1	Shroud, Motor, Bracket, Lower	14501425
7	1	Shroud, Motor, Bracket, Upper, N.P.O., Wall (> 2/3/17)	14501426
8	1	Shroud, Motor, Plate, External, Univ, FSTX/FR	65000928
	1	Shroud, Motor, Plate, External, Univ, FSTX LD/FR LD	65000864
9	4	Screw, Thumb, 1/4-20 x 1/2in, GR2 znc	64860019
10	4	Washer, Flat, 1/4x9/16inx3/32in, Neoprene	74110007
11	8	Virtual Vision Mounting Bracket	14501437
	2	Nut, Hex, Nylon, Lock, #10-24, zinc	55600004
	2	Screw, RHMS, Phillips, #10-24 x 3/4in, zinc	67850030
12	4	Kit, Virtual Vision Warning Plate Label	53700917
	2	Nut, Hex, Nylon, Lock, #10-24, zinc	55600004
	2	Screw, RHMS, Phillips, #10-24 x 1/2in, zinc	67850008
13	4	Virtual Vision LED Assembly	7623
14	2	KIT,FAN,208-230V,60HZ,3PH	53701092
	2	KIT,FAN,220V,60HZ,1PH	53701093
	2	KIT,FAN,220V,50HZ,1PH	53701094
	2	KIT,FAN,400V,50HZ,3PH	53701095
	2	KIT,FAN,460V,60HZ,3PH	53701096
	2	575V 3PH Curtain Fan	13250090
15	2	Fan Arm	11500046
16	2	BRKT, ASSY, MNT, FAN	14501554
17	24	Nut, Hex, 3/8-16, S.S.	55630006
18	24	Washer, Flat, 3/8in x 1in x .063, S.S.	74130012
19	24	Washer, lock, 3/8in, S.S.	74130009
20	12	Plate, 6in Ø, znc	65000723
21	12	Rod, Threaded, 3/8-16 x 12in S.S.	67900047
22	2	Poly Lumber Header Shim	69000015
23	6	Upper Track Weld Plate	65000588
24	16	Lower Track Weld Plate	65000587
25	a/r	Rivet, Blind, Fablok, 5/16in x 1.807	66840016
26	1	Poly Lumber Install Kit	5339

#	QTY	DESCRIPTION	PART #
27	a/r	Poly Lumber 1 1/2in x 8 1/2in x 10ft-6in	65450129
28	a/r	Kit, Install, Thru-Wall, Steel	53700887
29	1	Perimeter Seal	6680
30*	1	Kit, FSTX, Shroud, Motor, N.P.O., SLTD, RH (< 2/3/17)	53701010
31*	1	Kit, FSTX, Shroud, Motor, N.P.O., SLTD, LH (< 2/3/17)	53701011

*Not Shown

PARTS

Drive System (FasTrax, FasTrax FR)

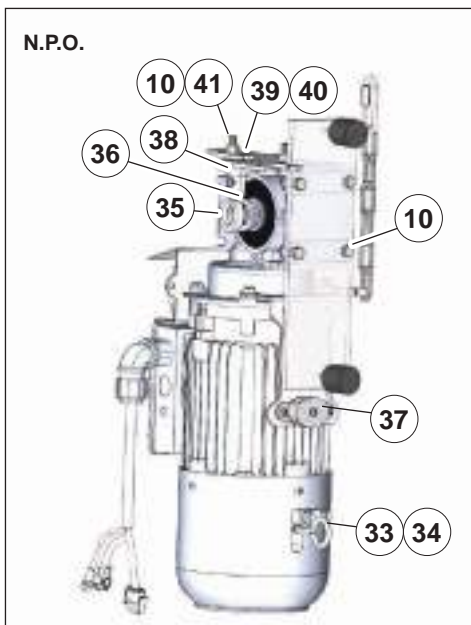
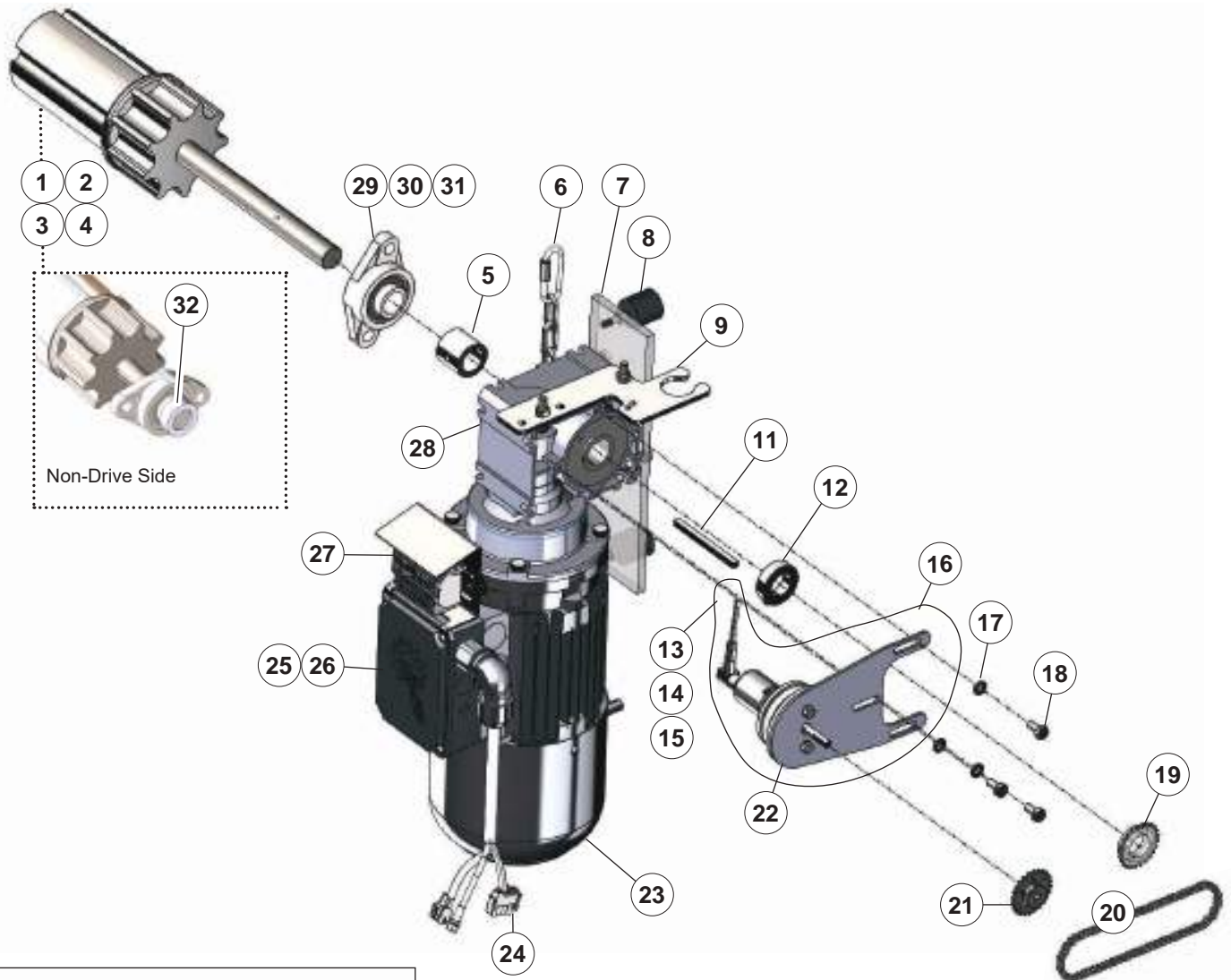

PARTS

Drive System (FasTrax, FasTrax FR) *Continued*

#	QTY	DESCRIPTION	PART #
1	1	Drive Tube Ass'y	6749
2	1	Kit, FasTrax, Sprocket, Drive	53700865
3	1	Kit, FasTrax, Sprocket, Non-Drive	53700866
4	1	Kit, FasTrax, Sprocket, Chain Hoist	53700867
5	1	Gearbox Spacer	53700705
6	1	Chain Kit	53700650
7	1	Drive Bracket	65000564
8	2	Motor Bumper	15250081
9	1	Conduit Bracket	14501418
10	6	Hex Lock Nut	55620010
11	1	Gearbox Key	53550010
12	1	Lock Collar	16850018
13	1	Encoder Cable 12ft [3658mm]	15650256
14	1	Encoder Cable 25ft [7620mm]	15650257
15	1	Encoder Cable 50ft [15240mm]	15650258
16	1	Encoder Kit #50	53700784
17	3	Lock Washer	74120002
18	3	M8-1.25 x 16mm	67930016
19	1	Sprocket Drive, 24 Tooth, 1in ID	70800047
20	1	Encoder Chain	16600063
21	1	Sprocket Driven, 24 Tooth, 5/16in ID	70800048
22	1	Encoder Plate	65000724
23	1	Motor/Brake/Gearbox Ass'y	5535
24	1	CBL,ASY,MTR/BRK,TRAX/FR,NORD	15650319
25	1	Brake Rectifier 230/460V	66270009
26	1	Brake Rectifier 575V	66270012
27	1	Terminal Assembly	73100093
28	-	Gearbox Ratios	(See table)
29	2	Flange Bearing	12500034
30	4	Bolt, HHMS, 1/2-13 x 1in, GR5, znc	67900003
31	4	Washer, Lock, Ext, 1/2in, znc	74150019
32	1	Collar, Shaft, Lock, 1in Dia., Cone Pt (Non-drive side)	16850014
33	1	Hex Nut	55680001
34	1	Eye Bolt	67930001
35	1	Spacer, N.P.O., FSTX	70450192
36	1	Washer, Flat, 1 x 1-1/2 x 1/8, HDN	74170007
37	1	Pulley, Assembly, FSTX, N.P.O.	65750070
38	1	Bracket, Mount, N.P.O.	14501419

#	QTY	DESCRIPTION	PART #
39	2	Screw, HHMS, 1/4-20 x 1/2, GR5, ZNC	67860002
40	2	Washer, Lock, Split, 1/4, ZNC	74110004
41	6	Screw, HHMS, 5/16-18 x 1-1/4, GR5, ZNC	67870003
*	1	Aero Lubriplate	54650001

*Not Shown

Gearbox Ratios

RATIO	NON-INSULATED CURTAIN	INSULATED CURTAIN	PART #
5:1	Doors <= 144ft ² [13.4M ²]	Doors < 112ft ² [10.4M ²]	51250026
7.5:1	Doors > 144ft ² [13.4M ²] and <= 196ft ² [18.2M ²]	Doors => 112ft ² [10.4M ²] and <= 160ft ² [14.9M ²]	51250027
10:1	Doors > 196ft ² [18.2M ²]	Doors > 160ft ² [14.9M ²]	51250028

PARTS

Drive System (FasTrax LD, FasTrax FR LD)

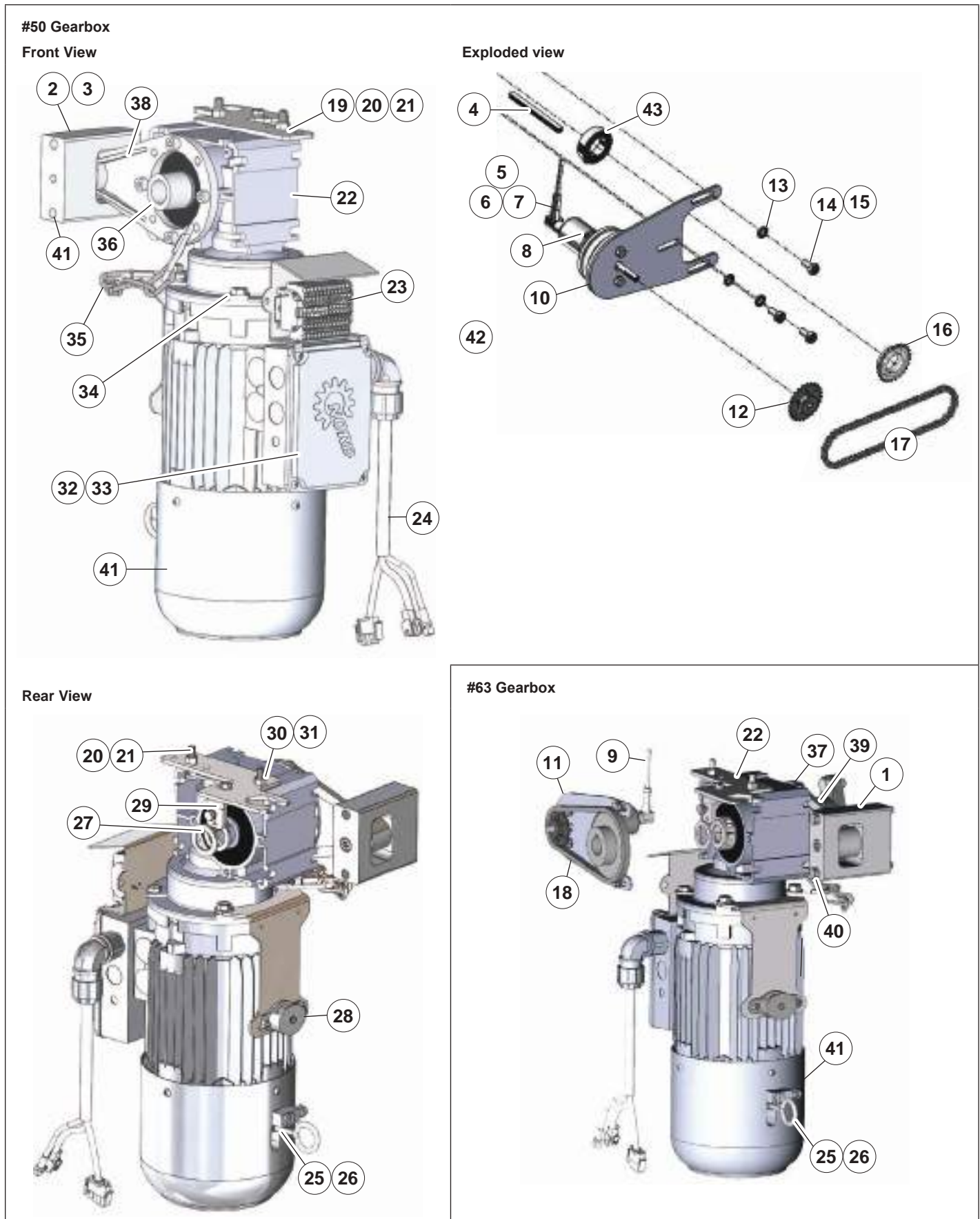

PARTS

Drive System (FasTrax LD, FasTrax FR LD) *Continued*

#	QTY	DESCRIPTION	PART #
1	1	BLOCK,MNT,NORD ARM,DFNDR	13000065
2	1	BLOCK,MNT,NORD ARM,TRXLD	13000060
3	1	Screw, SHCS, M10-1.5 x 80MM	67930032
4	1	Gearbox Key	53550010
5	1	Encoder Cable 12ft [4M]	15650256
6	1	Encoder Cable 25ft [8M]	15650257
7	1	Encoder Cable 50ft [17M]	15650258
8	1	Kit, Encoder, Gearbox, #50	53700784
9	1	Kit, Encoder, Gearbox, #63 (FSTX LD/FR LD)	53700878
10	1	Encoder Plate, #50	65000724
11	1	Encoder Plate, #63	65000805
12	1	Sprocket Driven 24T 1in ID	70800048
13	3	Lock Washer	74120002
14	3	M8-1.25x16MM (10:1, 15:1 GBX)	67930016
15	3	M10-1.50x20MM (20:1 GBX)	67930036
16	1	Sprocket Drive 45T 5/16in ID	70800064
17	1	Encoder Chain, #25 19in [483mm]	16600074
18	1	Encoder Chain, #25 21in [533mm]	16600067
19	1	Conduit Bracket	14501418
20	2	Nut, Hex, Lock, 5/16-18, znc	55620010
21	2	Screw, HHMS, 5/16-18x1 1/4in, GR5, znc	67870003
22	-	Gearbox (See Gearbox Ratios table)	-
23	1	Terminal Assembly	73100093
24	1	Cable, Assembly, Motor/Brake	15650319
25	1	Nut, Hex, 6M-1	55680001
26	1	Bolt, Eye, 6Mx30MM, znc	67930001
27	2	Washer, Flat, 1 x 1-1/2 x 1/8, HDN	74170007
28	1	Pulley, Assembly, FSTX, N.P.O.	53701036
29	1	Bracket, Mount, N.P.O.	14501419
30	2	Screw, HHMS, 1/4-20 x 1/2, GR5, ZNC	67860002
31	2	Washer, Lock, Split, 1/4, ZNC	74110004
32	1	Bridge Rectifier, 2A, 110-230V	66270009
33	1	Brake Rectifier 575V	66270012
34	4	Washer, Flat, 5/16, znc	74120003
35	1	Chain Kit	53700650
36	1	Spacer, Gearbox Nord, #50	70450168
37	1	Spacer, Gearbox Nord, #63	70450167
38	1	Torque Arm, Gearbox, #50	11500049
39	1	Torque Arm, Gearbox, #63	11500083

#	QTY	DESCRIPTION	PART #
40	2	SCR,HHMS,3/8-16X4,NYL PATCH,Z5	67880140
41	2	SCR,HHMS,3/8-16X4-1/2,NYL PATCH,Z5	67880141
42	1	Kit, Motor/Brake/Gearbox	5540
43	1	Lock Collar	16850018
*	1	Aero Lubriplate	54650001

*Not Shown

Gearbox Ratios

RATIO	CURTAIN	PART #	
		GEARBOX	MOTOR
Non-Insulated LD Curtain – All Specifications and Voltages			
10:1 (Sz 50)	Doors < 144ft² [13.4M²]	51250028	55250138, 139, 143
15:1 (Sz 63)	Doors ≥ 144ft² [13.4M²], ≤ 196ft² [18.2M²]	51250052	55250138, 139, 143
20:1 (Sz 63)	Doors > 196ft² [18.2M²]	51250047	55250138, 139, 143
Insulated LD Curtain – Standard Specifications (Non 575V)			
10:1 (Sz 50)	Doors < 112ft² [10.4M²]	51250028	55250138, 143
15:1 (Sz 50)	Doors ≥ 112ft² [10.4M²], ≤ 160ft² [14.9M²]	51250053	55250213, 214
15:1 (Sz 63)	Doors > 160ft² [14.9M²]	51250052	55250138, 143
Insulated LD Curtain – Canadian Specifications (All 575V)			
10:1 (Sz 50)	Doors < 112ft² [10.4M²]	51250028	55250138, 143, 139
15:1 (Sz 63)	Doors ≥ 112ft² [10.4M²]	51250052	55250138, 143, 139

PARTS

Curtain

Curtain Assembly

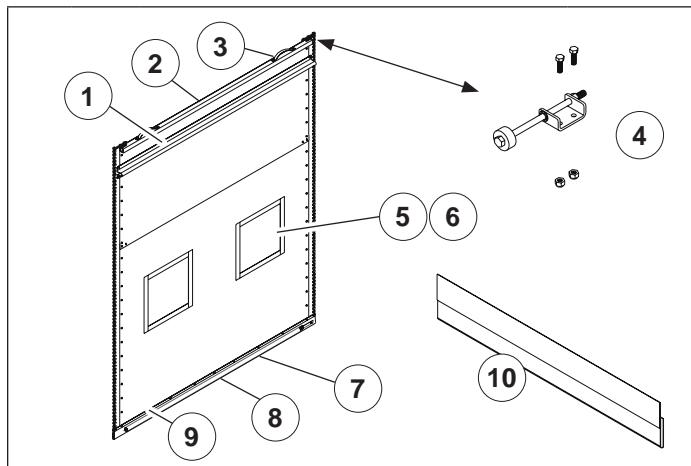

#	QTY	DESCRIPTION	PART #
1	1	Kit, Lintel Seal	6890
2	1	Curtain, Stiffener	7181
3	2	Curtain, Handle	75000023
4	1	Kit, Curtain Top Roller (includes 2)	53700562
5	a/r	Vision only Replacement, Urethane, 20in x 20in [508mm x 508mm] used on doors that currently do not have replaceable visions	53700711
	a/r	Cover, Window, UV, 20in x 20in [508mm x 508mm], Replaceable (=> 10/6/09)	17900163
	1	Kit, Vision Replacement, Urethane, Max View	7411
6	a/r	Kit, Vision/Screen Replacement, 20in x 20in [508mm x 508mm] (< 6/20/12) used on doors that currently do not have replaceable vision/screen	53700857
	a/r	Cover, Window/Screen, 20in x 20in [508mm x 508mm] (=> 10/6/09)	17900190
	1	Curtain order includes 1 tube of Super Lube	54650002
7	1	Curtain, Weight Assembly, Soft Edge	7541
8	1	Curtain, Bottom Loop	6893
	1	Curtain, Insulated, Bottom Loop	6895
9	1	Curtain, Assembly, FasTrax	2876
	1	Curtain, Assembly, FasTrax, Insulated	2877
10	1	Kit, Bottom Loop Seal Replacement	6893

Patch Kits

QTY	DESCRIPTION	PART #
a/r	Kit, Curtain, Patch, PVC, 27 oz, Blue	53700558
a/r	Kit, Curtain, Patch, 60 mil, Blue	53700559
a/r	Kit, Curtain, Patch, Urethane, 27 oz, Blue	53700774
a/r	Kit, Curtain, Patch, PVC, 27 oz, Green	53700667
a/r	Kit, Curtain, Patch, PVC, 27 oz, Gray	53700668
a/r	Kit, Curtain, Patch, PVC, 27 oz, Orange	53700669
a/r	Kit, Curtain, Patch, 100 mil, Blue	53700670
a/r	Kit, Curtain, Patch, 100 mil, Green	53700671
a/r	Kit, Curtain, Patch, 100 mil, Gray	53700672
a/r	Kit, Curtain, Patch, 100 mil, Orange	53700673
a/r	Kit, Vision, Patch, 30oz, Clear	53700778
a/r	Kit, Curtain, Patch, 100mil, Red	53700757
a/r	Kit, Curtain, Patch, 100mil, White	53700758

Curtain Vision

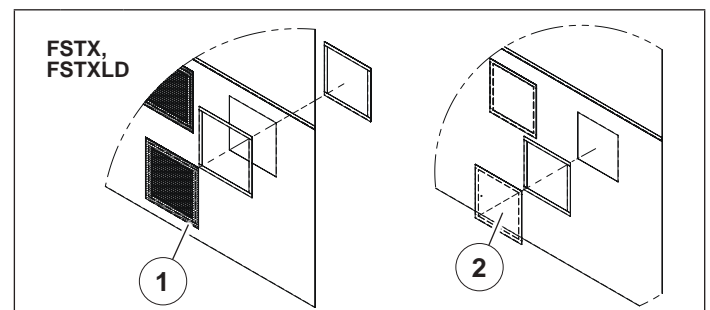

#	QTY	DESCRIPTION	PART #
1	a/r	Cover, Screen Window Gray, FasTrax 96in [2438mm] ≤ D.O.W. < 132in [3353mm] (Qty = 2) 132in [3353mm] ≤ D.O.W. < 170in [4318mm] (Qty = 3) 170in [4318mm] ≤ D.O.W. < 228in [5791mm] (Qty = 4) 228in [5791mm] ≤ D.O.W. ≤ 288in [7315mm] (Qty = 5)	17900190
2	a/r	Cover, Window, UV Inhibited, FasTrax 96in [2438mm] ≤ D.O.W. < 120in [3048mm] (Qty = 2) 120in [3048mm] ≤ D.O.W. < 156in [3962mm] (Qty = 3) 156in [3962mm] ≤ D.O.W. < 204in [5182mm] (Qty = 4) 204in [5182mm] ≤ D.O.W. < 252in [6401mm] (Qty = 5) 252in [6401mm] ≤ D.O.W. ≤ 288in [7315mm] (Qty = 6)	17900163

Drive Spheres

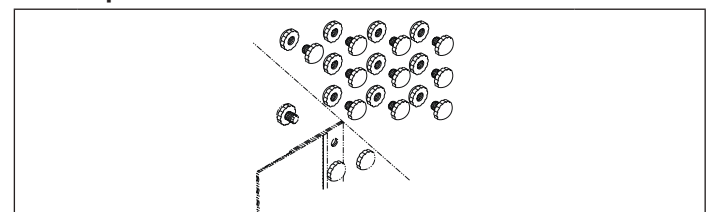

QTY	DESCRIPTION	PART #
a/r	Kit, Curtain, Drive Sphere, Qty 10	53700561

PARTS

Tracks, Spreader Bar

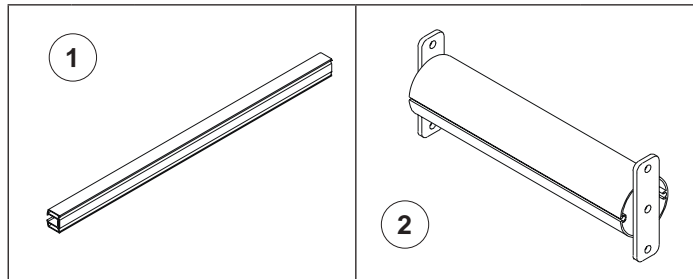

#	QTY	DESCRIPTION	PART #
1	2	Track, Upper, =< 10ft-0in [3048mm] O.D.H.	53700627
	2	Track, Upper, =< 12ft-0in [3658mm] O.D.H.	53700628
	2	Track, Upper, =< 14ft-0in [4267mm] O.D.H.	53700629
	2	Track, Upper, =< 16ft-0in [4877mm] O.D.H.	53700630
2	1	Radial Spreader Bar, Machined (=>8/13/10)	7256
	1	Radial Spreader Bar, Assembled (<8/13/10)	7257

Photoeye

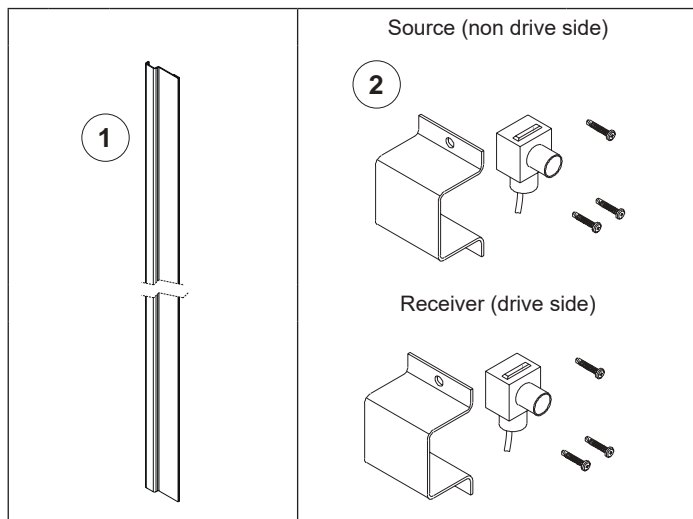

#	QTY	DESCRIPTION	PART #
1	2	Photoeye, Wiring Cover	1917
2	2	KIT, TRAX, PE and BRKT, SRC/RCVR, RSD	53701015

Drive Tube Assembly

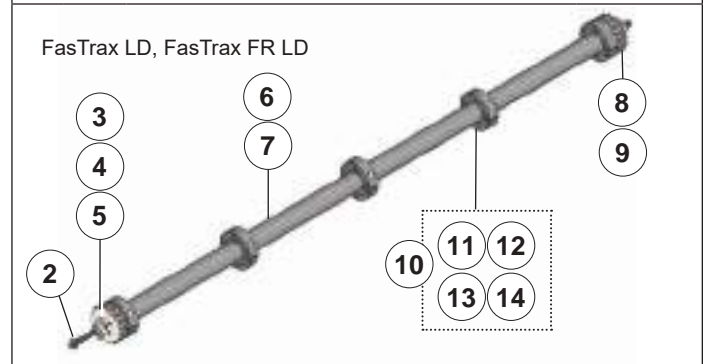
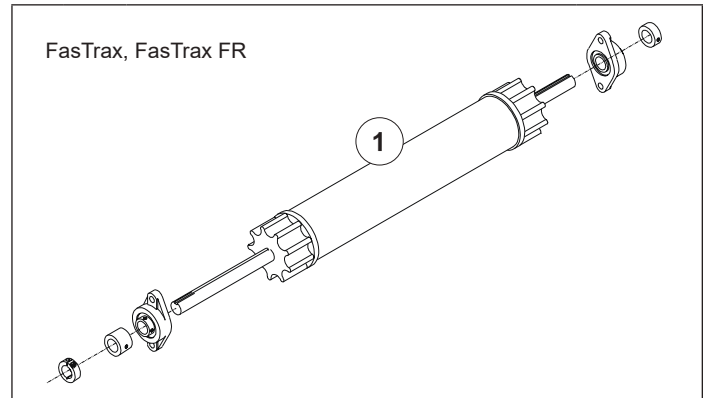

#	QTY	DESCRIPTION	PART #
1	1	FasTrax/FR Drive Tube, Assy	6749
2	2	Collar, Shaft, Lock, 1in Ø	16850018
3	2	Bearing, Flange, 1in Bore	12500034
4	4	Screw, HHMS, 1/2-13 x 1in, GR5, znc	67900003
5	4	Washer, Lock, Ext, 1/2in, znc	74150019
6	1	FasTraxLD/FRLD Drive Tube, Assy	6756
7	1	FasTraxLD/FRLD Drive Tube, Weld (Does not include Collars)	6757
8	2	FasTrax LD/FRLD Sprocket	70800061
9	8	Nut, Hex, Nyl, Lock, 3/8-16, znc	55630005
10	1	Kit, TraxLD/FRLD, Collar, Drive Tube	53700919
11	10	FasTraxFRLD Drive Tube Collar	16850025
12	10	Nut, Hex, Nyl, Lock, 1/4-20, znc	55610001
13	10	Screw, HHMS, 1/4-20x1 1/2in, GR5, znc	67860018
14	20	Washer, Flat, .281 x .62 x .125	74120012

PARTS

Lower Track Assembly, Radial

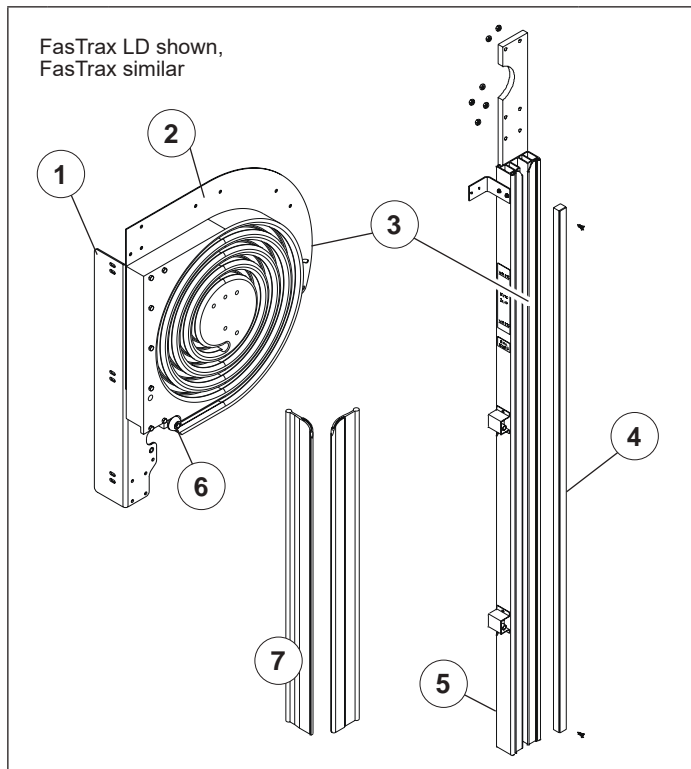

#	QTY	DESCRIPTION	PART #
1	1	Bracket, Radial, Large (>10ft [3048mm] D.O.H.), FSTX RH	14501197
	1	Bracket, Radial, Large (>10ft [3048mm] D.O.H.), FSTX LH	14501198
	1	Bracket, Radial, Small (<=10ft [3048mm] D.O.H.), RH	14502048
	1	Bracket, Radial, Small (<=10ft [3048mm] D.O.H.), LH	14502049
	1	Bracket, Header, Radial, Large, TRAXLD, RH	14501292
	1	Bracket, Header, Radial, Large, TRAXLD, LH	14501293
2	1/2	Upper Track, Radial (For doors > 8/6/10, For doors < 8/6/10 use 5227) FSTX	7368
	1/2	Upper Track, Radial (For doors > 8/6/10) For doors < 8/6/10 use 5227 FSTX LD	7382
3	a/r	Super Lube	54650002
4	2	Seal, Lower Track (Ext only)	6894
5	a/r	Lower Track Assembly FSTX	7362
	a/r	Lower Track Assembly FSTX LD	7381
6	2	Kit, Trax, Roller, Radial	53700975
7	a/r	Breakaway Retention Strips	1481

Brackets, Guards

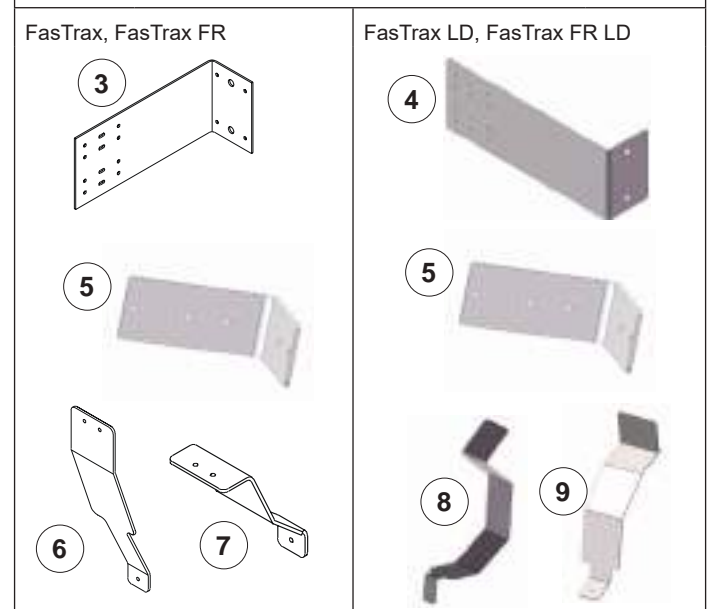

#	QTY	DESCRIPTION	PART #
1	1	Kit, FSTX, Bracket, Shroud, Motor, Top	53701009
2	a/r	Bracket, BEA Falcon	14501212
3	a/r	Track, Upper, Wall Mount Bracket (Includes hardware and 2 brackets)	53700881
4	4	Bracket, Wall, Mount, FasTrax TRAXLD	14501276
5	1	Shroud, Bracket, Lower	14501425
6	2	Guard, Drive Non-Radial (<8ft [2438mm] D.O.H.)	51300057
7	2	Guard, Drive Radial (<8ft [2438mm] D.O.H.)	51300058
8	2	Guard, Drive Non-Radial TRXLD (<8ft [2438mm] D.O.H.)	51300068
9	2	Guard, Drive Radial TRXLD	51300072

PARTS

Track, Re-feeds, Kits

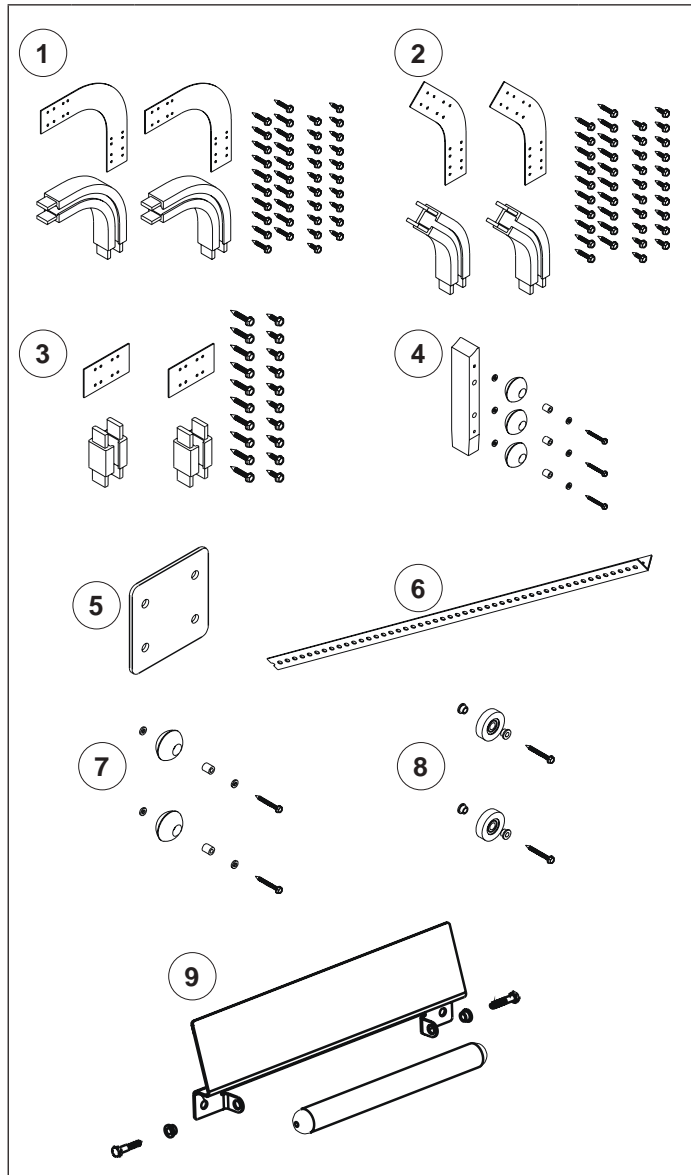

#	QTY	DESCRIPTION	PART #
1	1	Kit, Track Connector, Radius, 90°	53600185
2	1	Kit, Track Connector, Radius, 45°	53600189
3	a/r	Kit, Universal Track Connector	53600186
4	1	Kit, FasTrax, Re-feed, LH (bracket and 3 rollers)	53700606
	1	Kit, FasTrax, Re-feed, RH (bracket and 3 rollers)	53700607
5	2	Track, Joiner, Drive Cage	65000576
6	a/r	Track, Perforated, Angle, 2inx2inx13ft, 12GA (13ft)	71500030
7	(a/r)	Kit, FasTrax/FR, Re-feed Roller (2)	53700611
8	2	Kit, Radial Nylon Roller	53700632
9	a/r	Kit, Lintel Roller	67200091

Drive Cage

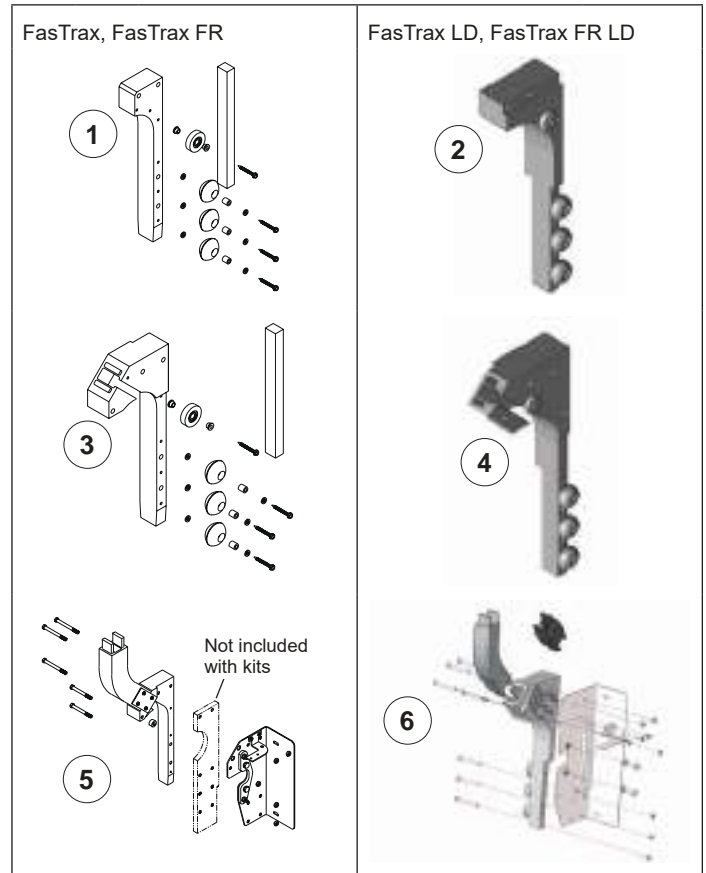

#	QTY	DESCRIPTION	PART #
1	1	Kit, Bracket, Drive Cage, Radial, Left	53700608
	1	Kit, Bracket, Drive Cage, Radial, Right	53700609
2	1	Kit, Bracket, Drive Cage, Radial, Left	53700943
	1	Kit, Bracket, Drive Cage, Radial, Right	53700944
3	1	Kit, Bracket, Drive Cage, Non Radial, L	53700645
	1	Kit, Bracket, Drive Cage, Non Radial, R	53700646
4	1	Kit, TRAXLD, Bracket, Drive Cage, N-Radial, Right	53700876
	1	Kit, TRAXLD, Bracket, Drive Cage, N-Radial, Left	53700877
5	1	Kit, VL/High Lift Drive Cage, L	53700616
	1	Kit, VL/High Lift Drive Cage, R	53700617
6	1	Kit, FSTXLD, DRVCG, N-Radial, Left	53701033
	1	Kit, FSTXLD, DRVCG, N-Radial, Right	53701034

PARTS

Radial Center Shroud (FasTrax, FasTrax LD)

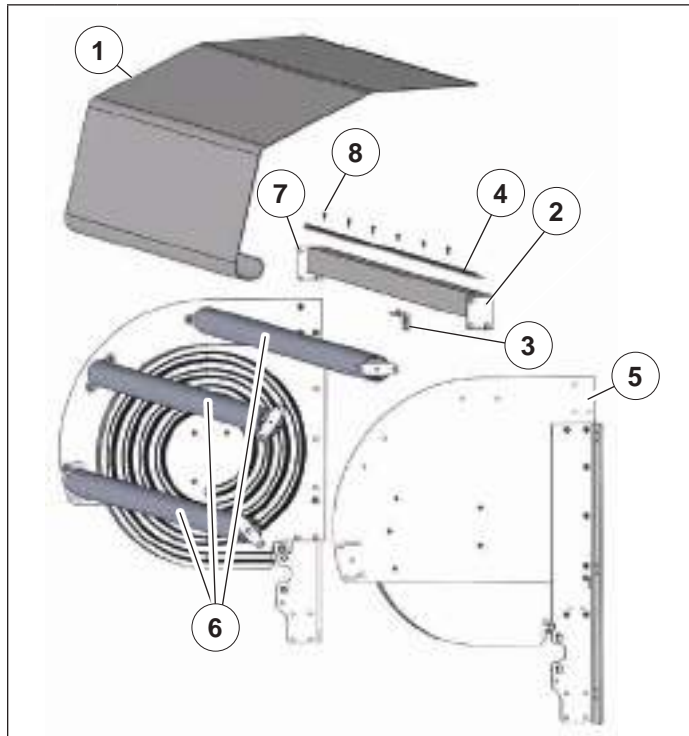

#	QTY	DESCRIPTION	PART #
-	1	Center Shroud Assembly	6947
1	1	Fabric Cover	1937
2	1	Shroud Wall Support	7238
3	1	Bracket, Wall Mount	14501167
	2	Screw, Self Tap/Drill #12	67850004
4	1	Trailer Rail	73400002
5*	2	Shroud End Plate, <=10ft-0in [3048 mm] D.O.H.	65000730
	2	Shroud End Plate, >10ft-0in [3048 mm] D.O.H.	65000731
*Not included in 6947			
6	3	Shroud Support	7237
	12	Nut, Hex, 3/8-16, znc	55630003
	12	Screw, HHMS, 3/8-16 x 1in, GR5, znc	67880002
	12	Washer, Lock, Split, 3/8in, znc	74130002
	12	Washer, Flat, .39 x .75 x .062, Nylon	74130003
7	6	Nut, Hex, 3/8-16, znc	55630003
	6	Screw, HHMS, 3/8-16 x 1in, GR5, znc	67880002
	6	Washer, Lock, Split, 3/8in, znc	74130002
	6	Washer, Flat, .39 x .75 x .062, Nylon	74130003
8	12	Screw, Self Tap/Drill #12	67850004

N.P.O.

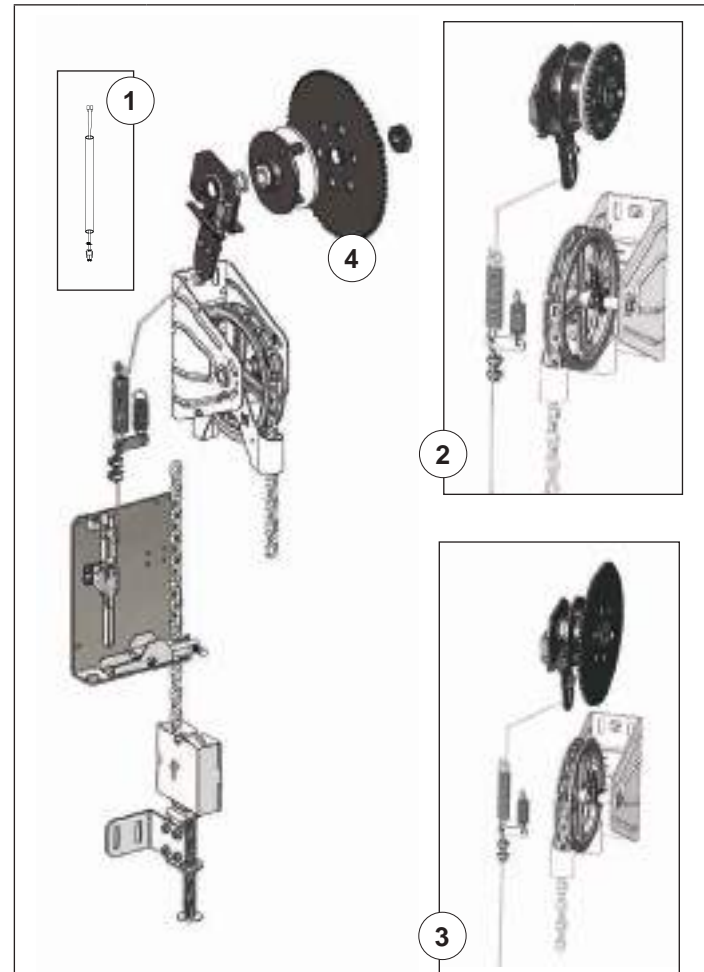

#	QTY	DESCRIPTION	PART #
1	1	N.P.O. Cable	15650234
2	1	FSTX/FR, N.P.O., 36 Tooth	56150055
3	1	FSTXLD/FRLD, N.P.O., 70 Tooth	56150056
4	1	Sprocket, #41, 70T, 1in Bore, Steel, LD/FRLD (Doors <2/3/17 only)	70800066
5*	1	Kit, FSTX, Upgrade, N.P.O.	2102
6*	a/r	Chain, N.P.O., Extension	16600076
7*	1	Kit, Pull Chain, N.P.O. (<2/6/17)	53701006
8*	1	Kit, FSTX, Shroud, Motor, Non Univ, RH (<2/6/17)	53701010
9*	1	Kit, FSTX, Shroud, Motor, Non Univ, LH (<2/6/17)	53701011

*Not Shown

PARTS

Upper Track

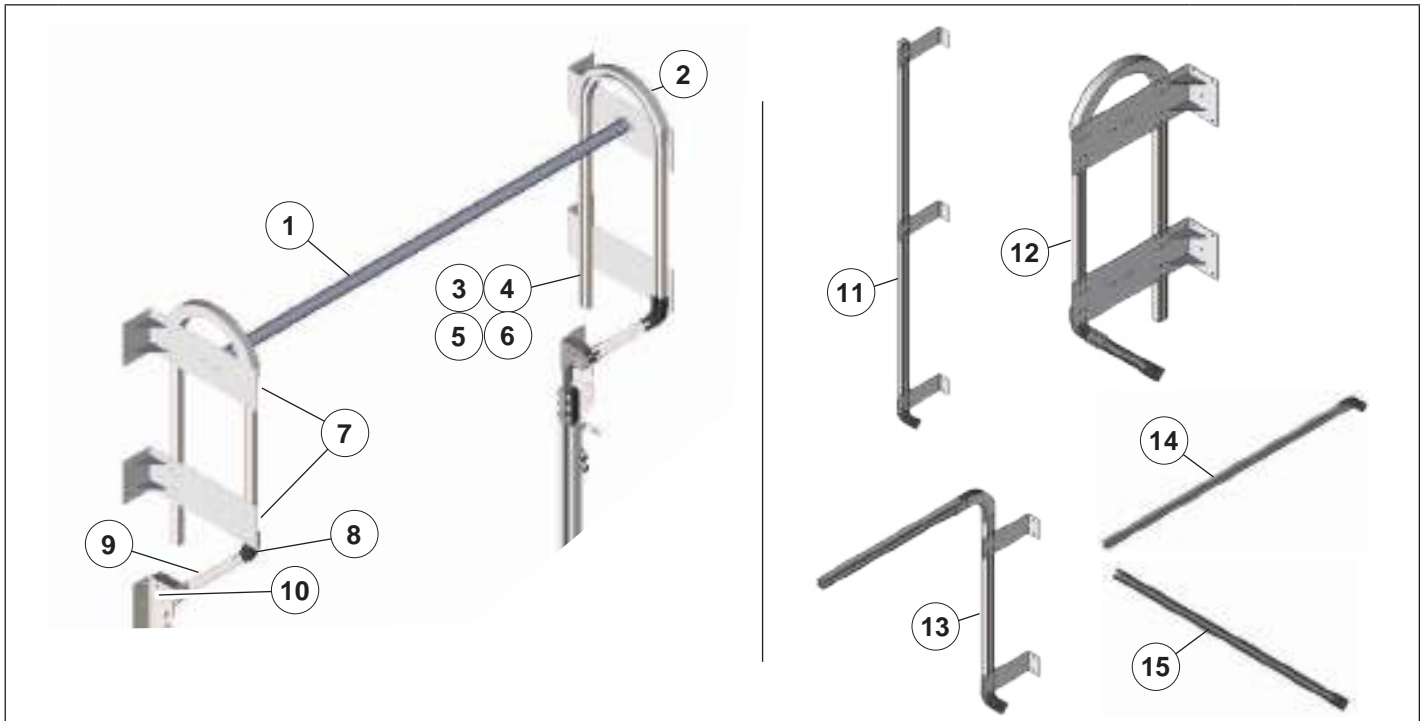

#	QTY	DESCRIPTION	PART #	
1	1	Spreader Bar, Wrapback, FSTX/FR/LD	7258	
2	2	Connector, 180°, Wrapback, FSTX	16950032	
3	2	Track, Upper, =< 10ft-0in [3048mm] O.D.H.	53700627	
4	2	Track, Upper, =< 10ft-0in [3048mm] O.D.H.	53700628	
5	2	Track, Upper, =< 10ft-0in [3048mm] O.D.H.	53700629	
6	2	Track, Upper, =< 16ft-0in [4877mm] O.D.H.	53700630	
7	4	Bracket, Upper Track, Wrapback, FSTX	14501277	
8	1	Kit, Track, Connector, Radius, 45°	53600189	
9	a/r	Kit, Universal Track Connector	53600186	
10	2	Connector, Radius, Universal, 45°	16960074	
			FSTX/ FSTXFR	FSTXLD/ FSTXFRLD
11	a/r	Upper Track, Vertical Lift	7368	7382
12	a/r	Upper Track, Wrapback	7368	7382
13	a/r	Upper Track, High Lift	7368	7382
14	a/r	Upper Track, Standard Lift	7368	7382
15	a/r	Upper Track, Tilt Lift	7368	7382

ABBREVIATIONS

ABBREVIATION	DESCRIPTION
AB	Allen Bradley
AC	Alternate Current
ACT	Activation
Amp	Amperage
A/R	As Required
Ass'y	Assembly
BL or BLK	Black
BRD/DRN	Braid or Drain Wire
BRGLD	Barrier Glider
BR or BRN	Brown
BRKT	Bracket
BRK	Brake
BTM	Bottom
BU	Blue
CC	Current Limiting
CE	European Commission
CL	Center Line
CL	Clean Door
CLR	Cooler Door
CR	Control Relay
CT	Control Techniques
C.W.	Counter Weight
CUI	Compact User Interface
DC	Direct Current
D.O.H.	Door Opening Height
D.O.W.	Door Opening Width
DR	Drill
E-Stop	Emergency Stop
Ext	Exterior
Ext/Ext	Exterior/Exterior
FHMS	Flat Head Machine Screw
F1,2,3	Fuse 1,2,3
FCC	Federal Communications Commission
FHWH	Flat Head Washer Head
FR/FZR	Freezer Door
FSTX	FasTrax
GBX	Gearbox
GN or GRN	Green
GND	Ground
GR	Grade
GY	Gray
HDW	Hardware
HHCS	Hex Head Cap Screw
HHMS	Hex Head Machine Screw
HWHMS	Hex Washer Head Sheet Metal Screw
H.P.	Horse Power

ABBREVIATION	DESCRIPTION
Hz	Hertz
illum	Illumination
ID	Inside Diameter
in	Inches
ind	Induction
Int	Interior
Int/Int	Interior/Interior
Int/Ext	Interior/Exterior
INV	Inverter
I/O	Input/Output
J-Box	Junction Box
KBPS	Kilobytes per second
KLDR	Time Delay Fuse
KVA	Kilo-Volt Ampere
L	Left
lb	Pounds
LCD	Liquid Crystal Display
LED	Light-Emitting Diode
LH	Left Hand
LHD	Left Hand Drive
L1,2,3	Line Voltage 1, 2, 3
LLC	Limited Liability Company
LTSPD	LiteSpeed
L/S	Limit Switch
M/D/Y	Month/Day/Year
Max	Maximum
MCR	Motor Contactor
Mhz	Mega Hertz
Mil/mm	Millimeters
Min	Minimum
Misc	Miscellaneous
MPH	Miles per hour
MSDC	Mounted Side DC
MSTP	Mounted Side Tie Point
N	Neutral
NMDC	Non-Mounted Side DC
NMTP	Non-Mounted Side Tie Point
N/A	Not Available
N.C.	Normally Closed
N.O.	Normally Open
N.P.O.	Non-Powered Opening
OB	Obstruction
OD	Outside Diameter
O.D.H.	Ordered Door Height
O.D.W.	Ordered Door Width
Opt	Optional

ABBREVIATIONS

ABBREVIATION	DESCRIPTION
OR or ORG	Orange
Oz	Ounce
PCB	Printed Circuit Board
PB	Push Button
PE	Photoeye
Pharma	Pharmaceutical
PHLP	Phillips Head
PHSMS	Pan Head Sheet Metal Screw
PK	Pink
P.M.P.	Planned Maintenance Program
Pos	Position
PSA	Pressure Sensitive Adhesive
PTR	Perimeter Seal
PVC	Polyvinyl Chloride
Qty	Quantity
R	Right
RD	Red
RH	Right Hand
RHD	Right Hand Drive
RHMS	Round Head Machine Screw
R/T	Roller Tube
SD	Secure Digital
SEC	Seconds
SF	Square Foot
SK	Control Techniques VFD
SPDT	Single Pole Double Throw
SPLT	SplitSecond
S.S./STNLS	Stainless Steel
STND/STD	Standard
SW	Switch (Disconnect)
Term	Terminal
TIG	Tungsten Insert Gas
UHMW	Ultra High Molecular Weight Polyethylene
UV	Ultra Violet
V	Voltage
VFD	Variable Frequency Drive
VL	Vertical Lift
V.V.	Virtual Vision
W.D.	Warning Device
w/	With
w/o	Without
WH	White
X	Controller Input
XFMR	Transformer
XL	Extra Large Door
Y	Controller Output

ABBREVIATION	DESCRIPTION
YE	Yellow
ZNC	Zinc
0V	Direct Current Common (Zero V)

2020-04-15

Rite-Hite Company, LLC and its affiliates (collectively "Rite-Hite") warrant that the Product sold to the Owner will be free of defects in design, materials and workmanship (ordinary wear and tear excepted) for the periods set forth below ("Limited Warranty").

Two (2) Year(s) on all mechanical and electrical parts (non-prorated).
 One (1) Year(s) labor, based on Rite-Hite approved travel and labor repair times.
 Five (5) Year(s) for motor, brake and gearbox material failure only.

REMEDIES

Parts: Rite-Hite's obligations under this Limited Warranty are limited to repairing or replacing, at Rite-Hite's option, any part which is determined by Rite-Hite to be defective during the applicable warranty period. Such repair or replacement shall be Rite-Hite's sole obligation and the Owner's exclusive remedy under this Limited Warranty.

Labor: Rite-Hite will provide warranty service without charge for labor per the specified warranty period. Thereafter, a charge will apply to any repair or replacement under this Limited Warranty.

CLAIMS Claims under this Limited Warranty must be made (i) within 30 (thirty) days after discovery and (ii) prior to expiration of the applicable warranty period. Warranty period commences on the date of shipment. Claims shall be made in writing or by contacting the representative from whom the Product was purchased directly. Owner must allow Rite-Hite or its agent, a reasonable opportunity to inspect any Product claimed to be defective and shall, at Rite-Hite's option, either (x) grant Rite-Hite or its agent access to Owner's premises for the purpose of repairing or replacing the Product or (y) return of the Product to the Rite-Hite, F.O.B. Rite-Hite's factory.

NOT WARRANTED Rite-Hite does not warrant against and is not responsible for wear items such as fuses, batteries, bulbs, vision and seals. No implied warranty shall be deemed to cover damages that result directly or indirectly from: (i) the unauthorized modification or repair of the Product, (ii) damage due to misuse, neglect, accident, failure to provide necessary maintenance, or normal wear and tear of the Product, (iii) failure to follow Rite-Hite's instructions for installation, failure to operate the Product within the Product's rated capacities and/or specified design parameters, or failure to properly maintain the Product, (iv) use of the Product in a manner that is inconsistent with Rite-Hite's guidelines or local building codes, (v) movement, settling, distortion, or collapse of the ground, or of improvements to which the Products are affixed, (vi) fire, flood, earthquake, elements of nature or acts of God, riots, civil disorder, war, or any other cause beyond the reasonable control of Rite-Hite, (vii) improper handling, storage, abuse, or neglect of the Product by Owner or by any third party.

DISCLAIMERS THIS LIMITED WARRANTY IS EXCLUSIVE AND IN LIEU OF ALL OTHER REPRESENTATIONS AND WARRANTIES, EXPRESS OR IMPLIED, AND RITE-HITE EXPRESSLY DISCLAIMS AND EXCLUDES ANY IMPLIED WARRANTIES OF MERCHANTABILITY OR FITNESS FOR PURPOSE. RITE-HITE SHALL NOT BE SUBJECT TO ANY OTHER OBLIGATIONS OR LIABILITIES, WHETHER ARISING OUT OF BREACH OF CONTRACT, WARRANTY, TORT (INCLUDING NEGLIGENCE AND STRICT LIABILITY) OR OTHER THEORIES OF LAW, WITH RESPECT TO THE PRODUCTS SOLD OR SERVICES RENDERED BY RITE-HITE, OR ANY UNDERTAKINGS, ACTS, OR OMISSIONS RELATING THERETO.

LIMITATION OF LIABILITY IN NO EVENT SHALL RITE-HITE BE RESPONSIBLE FOR, OR LIABLE TO ANYONE FOR, SPECIAL, INDIRECT, COLLATERAL, PUNITIVE, INCIDENTAL, OR CONSEQUENTIAL DAMAGES, EVEN IF RITE-HITE HAS BEEN ADVISED OF THE POSSIBILITY OF SUCH DAMAGES. Such excluded damages include, but are not limited to, personal injury, damage to property, loss of goodwill, loss of profits, loss of use, cost of cover with any substitute product, interruption of business, or other similar indirect financial loss.

170714

GLOBAL SALES AND SERVICE *Representatives in All Major Cities*

RITE-HITE WORLD HEADQUARTERS

8900 N. Arbon Drive
 P.O. Box 245020
 Milwaukee, Wisconsin 53224

☎ **414-355-2600**
 U.S. Only: **1-800-456-0600**

RITE-HITE CHINA

First Floor, Building #3,
 558 Tongxie Road,
 Changning District
 Shanghai 200335, China

☎ **+86-21-6237-6333**

RITE-HITE LATIN AMERICA

Alameda Lorena 800, conj. 1310
 - Jardim Paulista
 São Paulo-SP, CEP 01424-001
 - Brazil

☎ **+55-11-3527-9590**

RITE-HITE GMBH

Carl-Zeiss-Strasse 3
 34471 Volkmarsen, Germany

☎ **+49-5693 98700**