

4

3

2

1

NEXT ASSEMBLY

REVISION HISTORY					
REV	DESCRIPTION	ECH	DATE	BY	APPROVED
A	ADDED NOTE ABOUT RAISED BUMPERS	08-009	3/26/08	GDB	
B	ADDED "FOR REFERENCE ONLY" NOTE	11-010	3/29/2011	GDB	
C	UPDATED LOGO AND TITLE BLOCK	14-006	3/31/2014	GDB	

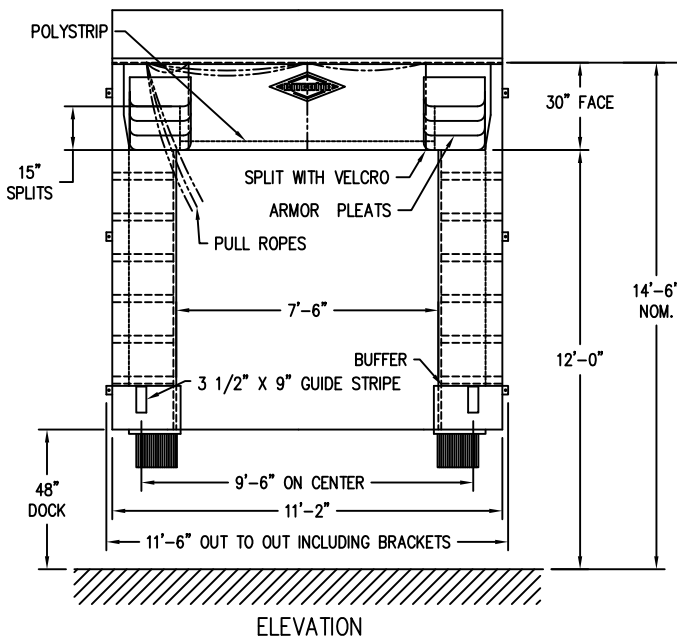

ELEVATION

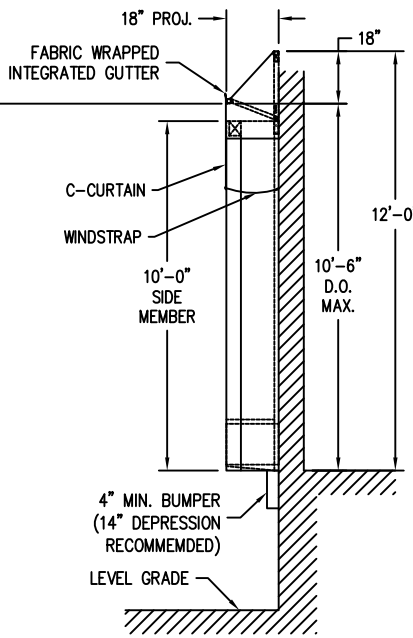

RIGHT SIDE ELEV.

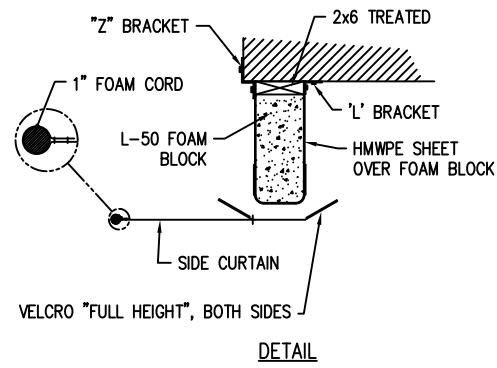

DETAIL

C STYLE CURTAIN: F114 22 PLUS, BLACK
 SIDE FRAME: F114 22 PLUS, BLACK
 SIDE CURTAIN: F114 22 PLUS, BLACK
 RECOMMENDED TRUCK COVERAGE: 12'-6" - 13'-6" HIGH
 X 8'-0" - 8'-6" WIDE

NOTE:
 APPLICATIONS THAT HAVE BUMPERS MOUNTED ABOVE DOCK HEIGHT (OR ABOVE THE PIT FLOOR IN VERTICAL LEVELER APPLICATIONS) MAY REQUIRE THAT THE BOTTOM OF THE SIDE MEMBERS BE MOUNTED AT THE TOP OF THE BUMPERS INSTEAD OF AT DOCK HEIGHT.

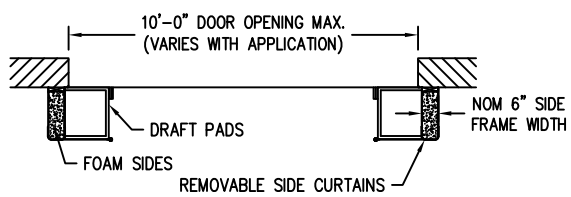

SECTION THRU PLAN

THIS DRAWING IS FOR REFERENCE ONLY.
 DO NOT USE FOR PRODUCTION PURPOSES.

INCH TOLERANCES			DO NOT SCALE DRAWING	
OVER	UP TO	+ / -	DATE	MM-DD-YY
0	0.125	0.005		
0.125	0.25	0.010		
0.25	1.25	0.020		
1.25	5	0.030		
5	15	0.040		
15	40	0.050		
40	80	0.100		
80	-	0.125		

ITEM	QTY	PART NO.	DESCRIPTION
PARTS LIST / MATERIAL			
RITE-HITE ENVIRONMENTAL ENCLOSURES CORP.			
TITLE			
ARCHITECTURAL APPROVAL			
610E SERIES SHELTER			
ELIMINATOR II-6" BACKERS, INTEGRAL HOOD			
SIZE	MODEL NUMBER	DWG NO	REV
C	610E	A7120085	C
SCALE 3/8"=1'		PART #	SHEET 1 of 1

DWG NO A7120085 SHEET 1 of 1