

An aerial photograph of a vast wind farm situated in rolling green hills. Numerous white wind turbines are scattered across the landscape, with some in the foreground and others receding into the distance. The terrain is characterized by gentle slopes and winding paths. The sky is clear and blue, and the overall scene conveys a sense of clean, renewable energy production in a natural setting.

Overview on the Dual Challenge: Energy & Climate

October 2024

OpenMinds' Mission & Identity



OUR MISSION

More energy. Less emissions.

Accelerate progress against the Dual Challenge by 203X

- 100+ volunteer experts
- 501(c)(3)
- Disciplined non-partisan selection process
- 360° systems engineering approach

WHAT MAKES US UNIQUE



Energy AND climate



Cross-functional expert team



Detailed solutions framework



Impact progress by 203X

OpenMinds' Solution Approach

We believe that addressing the Dual Challenge requires us to work together in a **non-partisan** manner across **diverse** fields, industries, and geographies

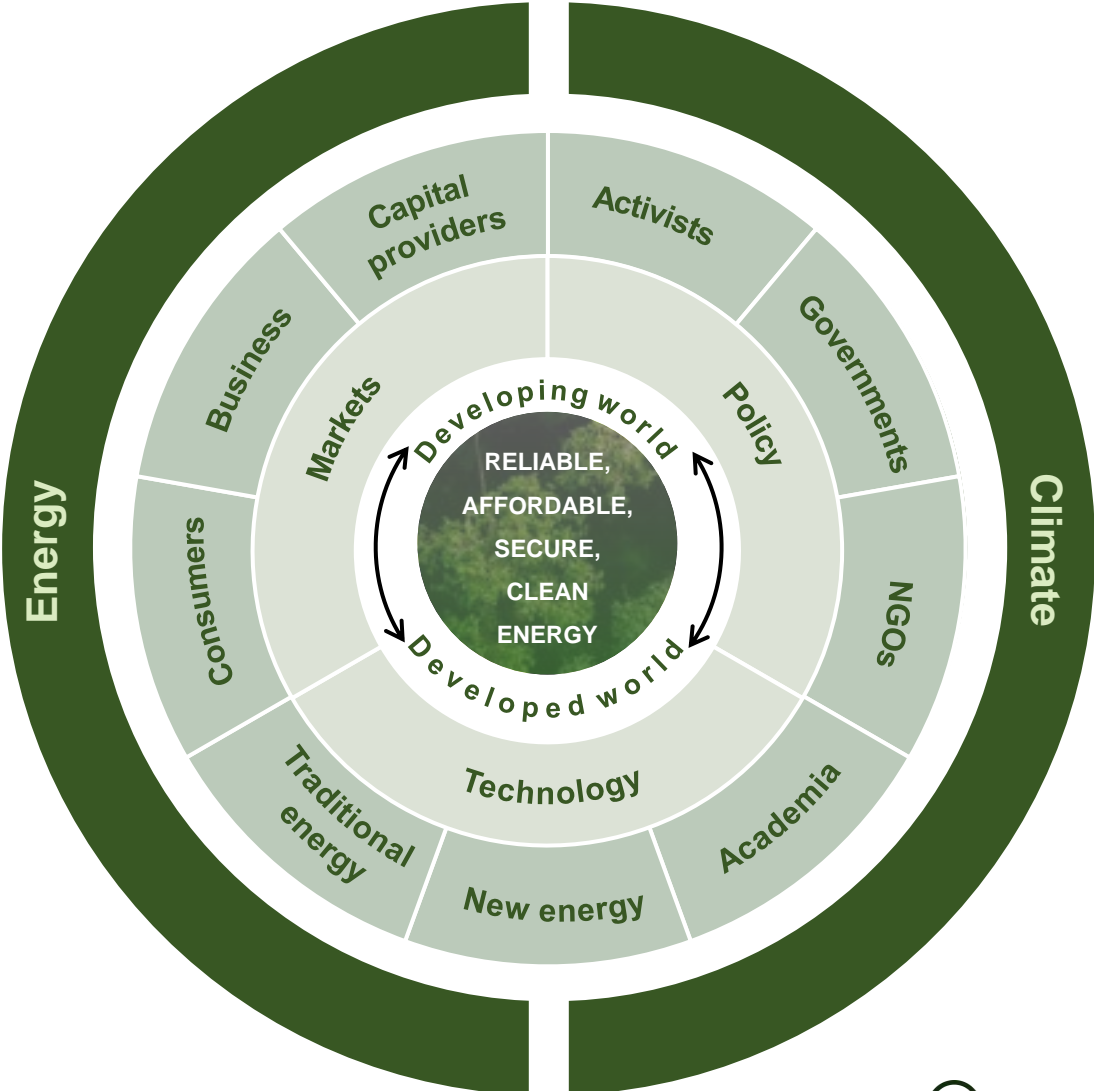

A Note on These Materials

Focus of this deck



Click to access more information about solutions

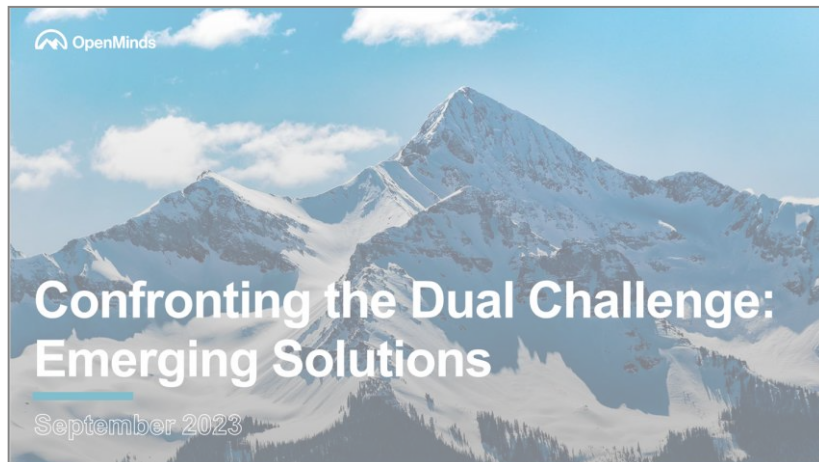

The purpose of this document is to define the “Dual Challenge” of meeting the growing demand for energy while reducing greenhouse gas emissions with the aim of enhancing the wellbeing of humans everywhere. **Our intent is for this to be accessible to anyone**, even those with no prior knowledge of energy or climate change.

In preparing these materials, **we drew from a range of sources**, including the IPCC’s Sixth Assessment Report, BP’s Statistical Review of World Energy, the Global Carbon Project, and others.

Section 2 (Energy) and **Section 3 (Climate)** serve as building blocks for successive chapters. Each begins with first principles, establishes civilizational relevance, provides an overview of energy demand and emissions over a three-decade period, and offers thoughts on the future.

Section 4 (Reality Check) summarizes long term trends and demonstrates that emissions reductions will almost certainly need to be done in the context of rising energy demand, which is the core of the Dual Challenge.

Section 5 (Headwinds & Tailwinds) presents a non-exhaustive overview of the forces, both favorable and unfavorable, influencing progress toward resolving the Dual Challenge.

It will take a global, “all of us” effort to address the Dual Challenge. **We hope these materials convey the importance of attending to the physical realities of both energy and climate, alongside the world’s economic and development needs, as we seek solutions.**

The Dual Challenge: An Overview



Energy is fundamental to human wellbeing and flourishing...



... but our primary energy sources, fossil fuels, are also the principal source of human greenhouse gas emissions, which **cause global warming**



The tension between energy supply and climate change presents the **Dual Challenge**



This is a **global** problem of enormous **scale and complexity**, and addressing it will require us to balance **competing priorities**



Section 1 – Slide 8
Executive Summary



Section 2 – Slide 44
Energy: Uses, Sources, and Outlook



Section 3 – Slide 75
Climate: Fundamentals and Possible Trajectories



Section 4 – Slide 111
Reality Check: Where We Are Today



Section 5 – Slide 127
The Dual Challenge: Headwinds and Tailwinds

Table of Contents

Agenda

An aerial photograph of a wind turbine in a lush green field. The turbine is the central focus, with its three blades extending outwards. The field is divided into sections by thin lines, possibly roads or irrigation channels. The overall scene is bright and clear, suggesting a sunny day.

01

**OpenMinds
and the Dual
Challenge:
Executive
Summary**

02

Energy: Uses,
Sources, and
Outlook

03

Climate
Change:
Fundamentals
and Possible
Trajectories

04

Reality Check:
Where We Are
Today

05

The Dual
Challenge:
Headwinds
and Tailwinds

The Dual Challenge

- Affordable, reliable energy forms the bedrock of modern civilization is key to human flourishing – and the world needs more of it.
- But our largest primary energy sources, fossil fuels, are also the largest sources of anthropogenic greenhouse gas emissions.
- These greenhouse gas emissions have a heat-trapping effect in the atmosphere leading to a rise in the earth’s average temperature over time.
- Warming presents risks over time, such as rising sea levels and an increase in the frequency and intensity of some forms of extreme weather.
- Solving solely for emissions and warming could jeopardize access to reliable, affordable energy in the developed and developing world.
- Conversely, solving for energy without considering climate will worsen the adverse effects of human-induced climate change in the future.
- Consequently, there is considerable tension between our need for abundant, affordable energy and the need to address the risks of climate change.

This tension presents the “**Dual Challenge**”—providing affordable, reliable, and secure energy for billions while simultaneously reducing the warming impact of our energy system, all in service of enhancing human wellbeing now and in the future.



Energy is Fundamental to Human Flourishing



Energy Has Played a Crucial Role in Economic and Human Development

Global energy consumption

PETAWATT-HOURS

Global GDP

TRILLIONS OF CONSTANT 2017 INTERNATIONAL USD, PPP ADJUSTED

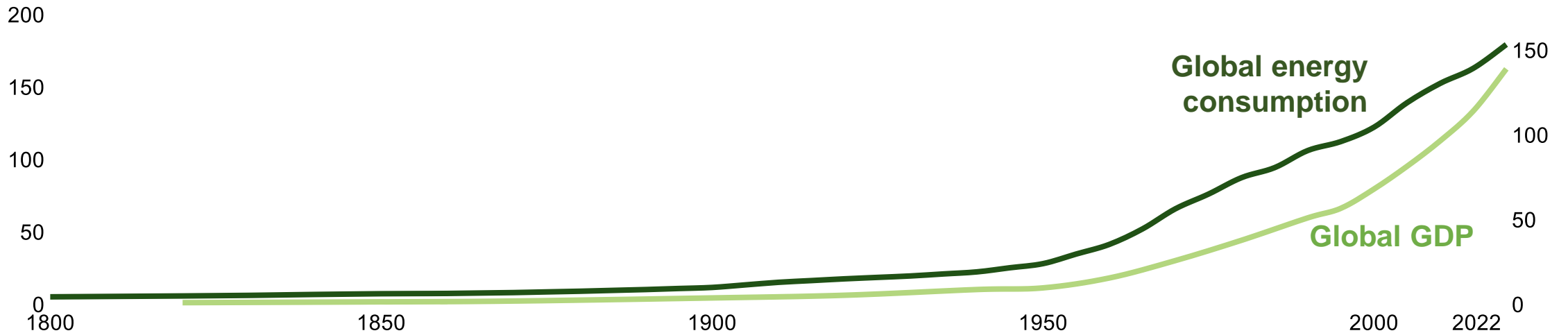

World population

1.0B

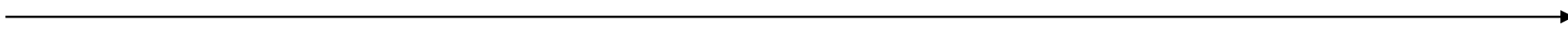

8.2B



Average life expectancy

29yrs.

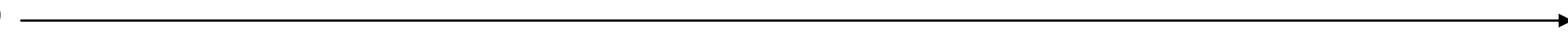

73yrs.



Note: GDP is adjusted for purchasing power parity. Sources: Vaclav Smil, *Energy Transitions: Global and National Perspectives*, 2017; Maddison Project Database, version 2020. Bolt, Jutta and Jan Luiten van Zanden (2020), "Maddison style estimates of the evolution of the world economy. A new 2020 update"; World Bank; Our World in Data

Energy Underpins Human Well-Being

Human development Index – 2019

The HDI is a summary measure of key dimensions of human development: a long and healthy life, a good education, and having a decent standard of living

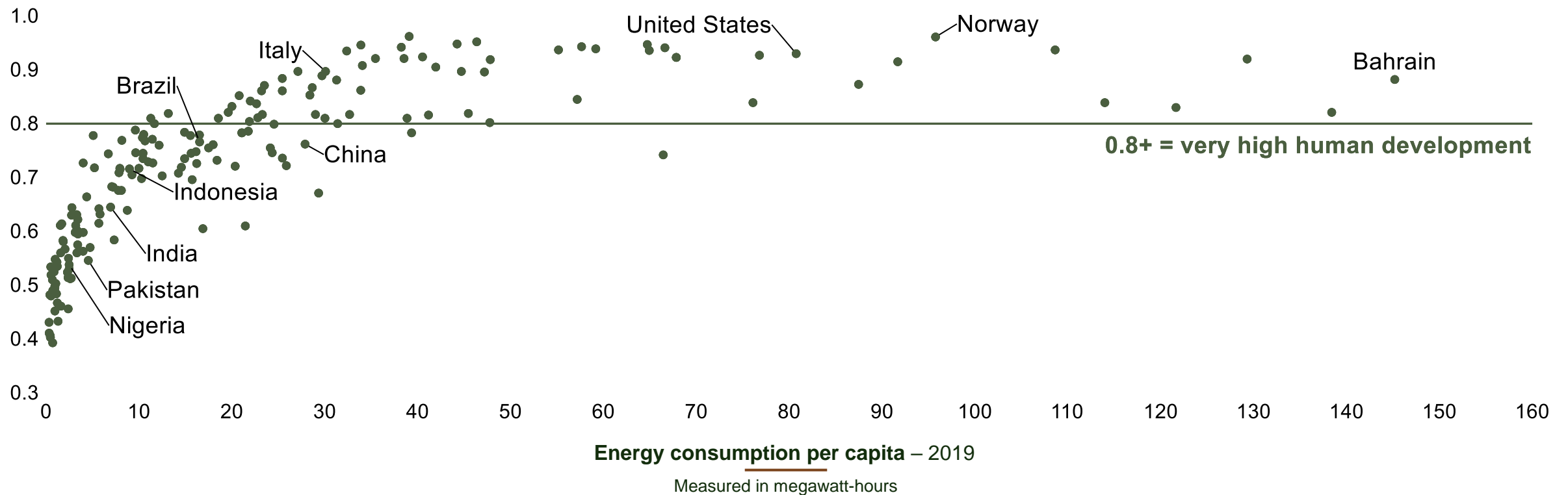

Source: Our World in Data; Center for Global Development; BP Statistical Review of World Energy, 2021; EIA

Energy Consumption is Highly Correlated With Economic Progress—and There is Still Considerable Inequality

Primary energy consumption per capita – 2019

Megawatt-hours

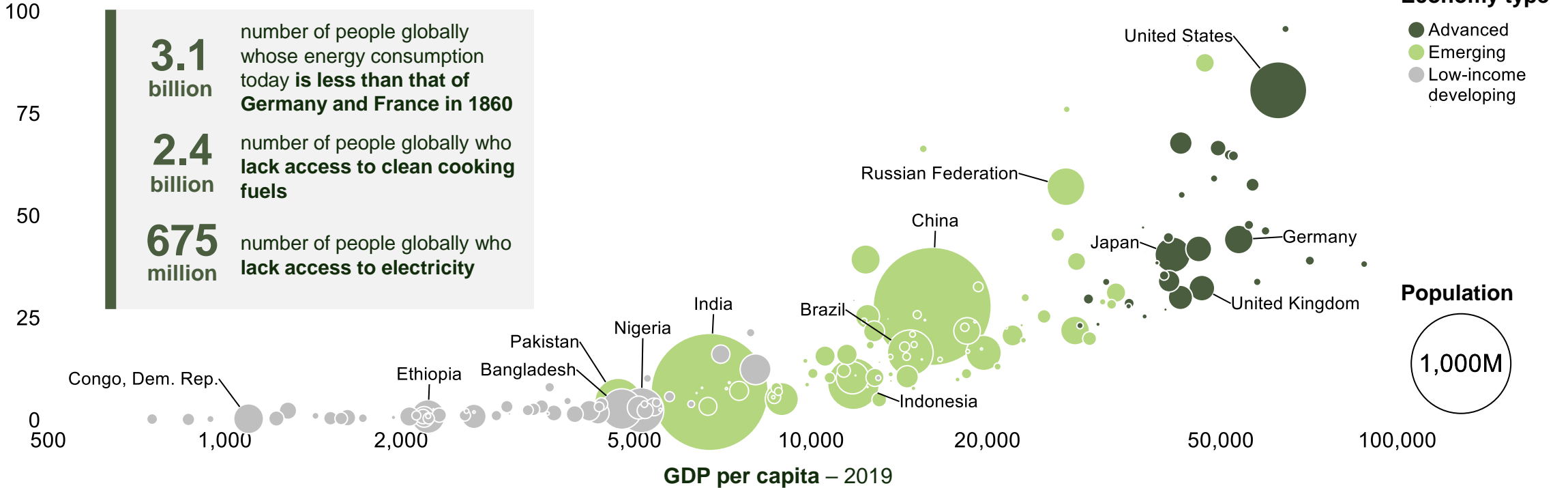

Source: Our World in Data; World Bank; IMF; Global Carbon Project; Vaclav Smil, *How the World Really Works*

Despite Progress, the World Needs More Energy

Energy consumption per capita, 2023 (shown as bars)
MEGAWATT-HOURS

1.4
billion

Expected population
growth in non-OECD
countries through
2050

Population, 2023 (shown as red lines)
BILLIONS

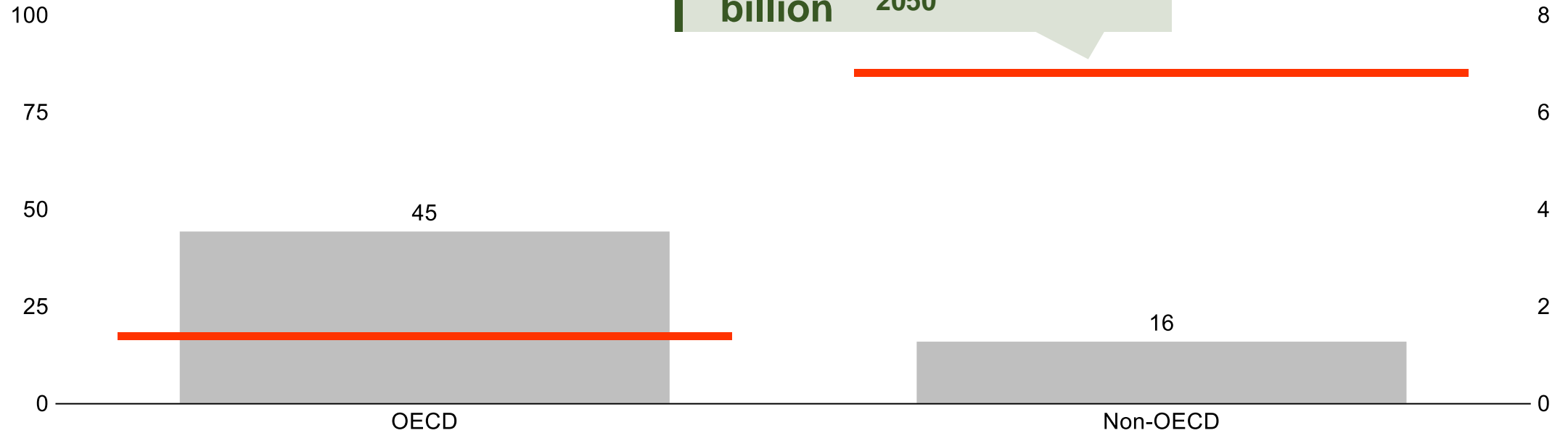

GDP per capita¹

\$40K

\$6K

Note: (1) GDP per capita is adjusted is measured in 2015 USD.
Source: World Bank; Exxon Global Energy Outlook 2024; IEA [Growth in Developing Countries](#)

But Conventional Energy is the Primary Source of Human Emitted Greenhouse Gases

Energy emissions
Emissions from the production and combustion of fossil fuels for power generation, heat generation, manufacturing/construction, transportation, and other uses

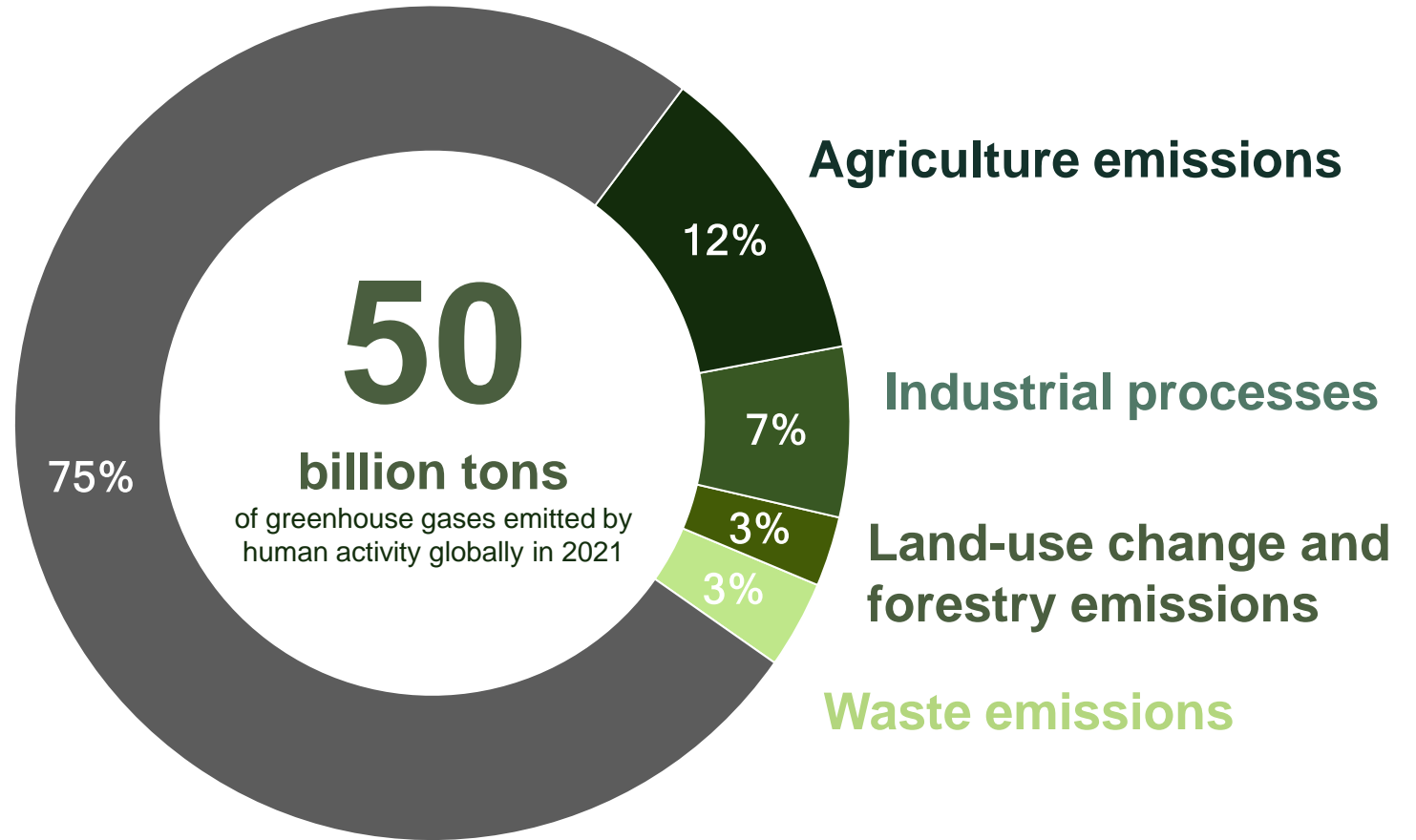

Note: Emissions measured in tons of CO2-equivalent and include carbon dioxide, methane, nitrous oxide, and f-gases
Source: Our World in Data; Climate Watch

But the Consumption of Traditional Sources of Energy Releases Greenhouse Gases like Carbon Dioxide (CO₂)

Cumulative global CO₂ emissions from energy and land use change

Measured in billions of tons of CO₂, from 1850 through 2021; excluding non-CO₂ emissions (e.g., methane)

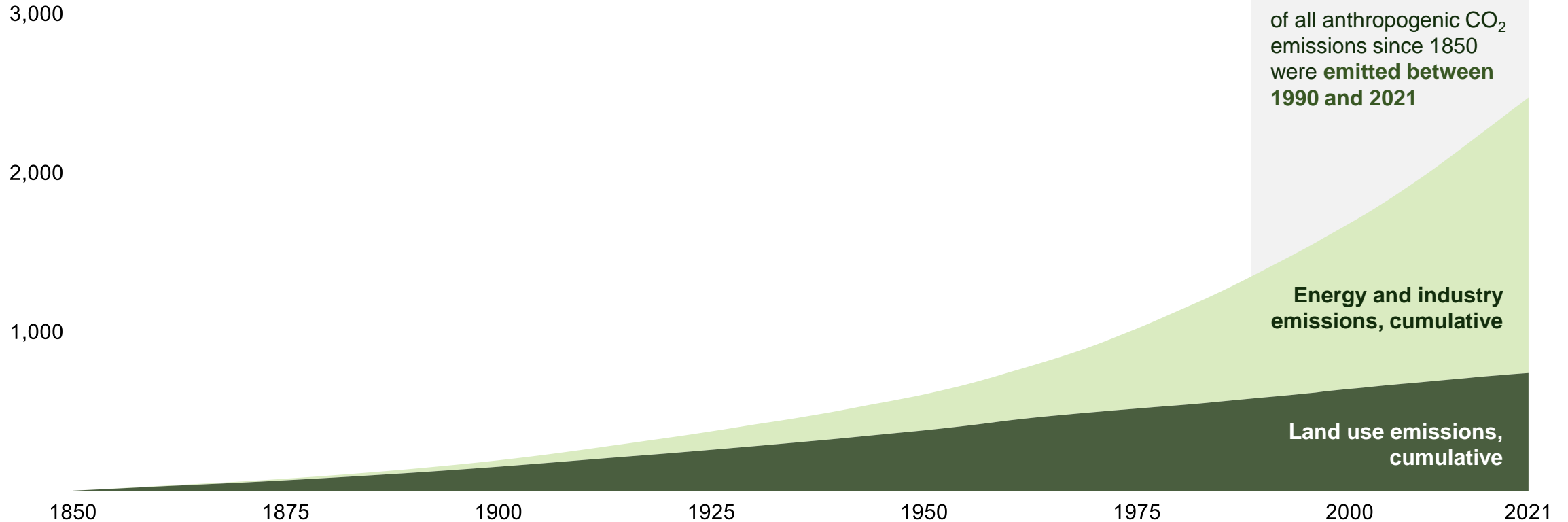

Source: Global Carbon Project; Our World in Data

1 CO₂ is Not The Only Greenhouse Gas, but it Accounts For the Majority of Anthropogenic Emissions

Carbon dioxide

Sources include fossil fuel (e.g., coal, oil, gas) combustion, cement production, steel production.



Nitrous oxide

Sources include agriculture (fertilizer), fossil fuel combustion, and industrial processes.



Methane

Sources include livestock, natural gas production, and landfills.



Fluorinated gases

Sources include electronics manufacturing, and aluminum production.

Note: * 2019 global emissions measured in tons of CO₂-equivalent
 Source: EPA; Climate Watch; IPCC, Fourth Assessment Report (AR4)

1

The Cumulative Effect of Human Emissions Has Caused the Earth to Warm 1.2°C

Average global temperature anomaly

°C

1.5°C

1.0

0.5

0.0

-0.5

-1.0

1850

1870

1890

1910

1930

1950

1970

1990

2010

2023

Atmospheric CO₂ concentration

PARTS PER MILLION (PPM)

500ppm

400

300

200



1.2°C

Approximate warming since pre-industrial times

Median global temperature anomaly

Atmospheric CO₂ Concentration

Note: The green line represents the median average temperature deviation, or anomaly, vs. the 1961-1990 baseline (average) value. Atmospheric CO₂ concentration reflects the annual average.
 Source: Hadley Center; NOAA; IPCC, Sixth Assessment Report (AR6), *Climate Change 2021: The Physical Science Basis, Summary for Policymakers*, A.1.2 (2022); Our World in Data

The Greenhouse Effect is the Physical Process that Links Anthropogenic GHG Emissions to Warming

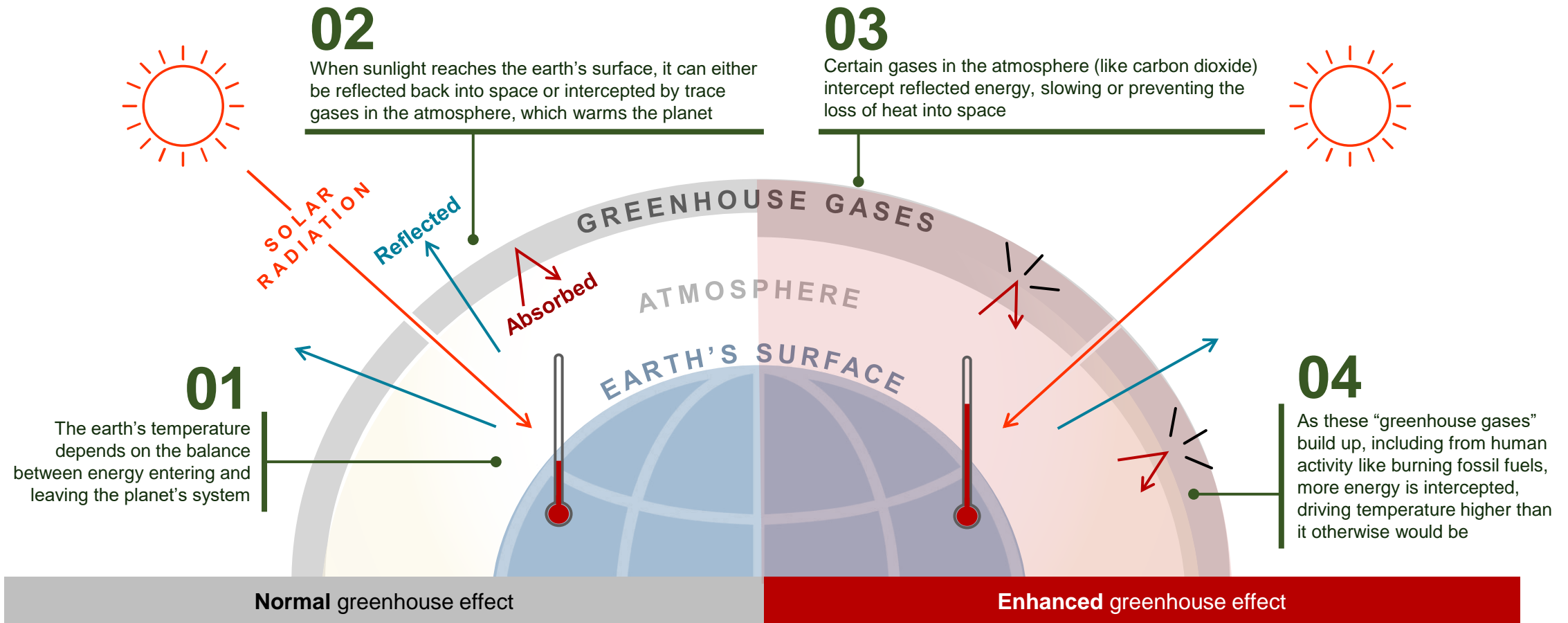

And History Suggests “a Little is a Lot” With Respect to Temperature Changes

Last ice age

when ~25% of Earth's land area was covered in glaciers

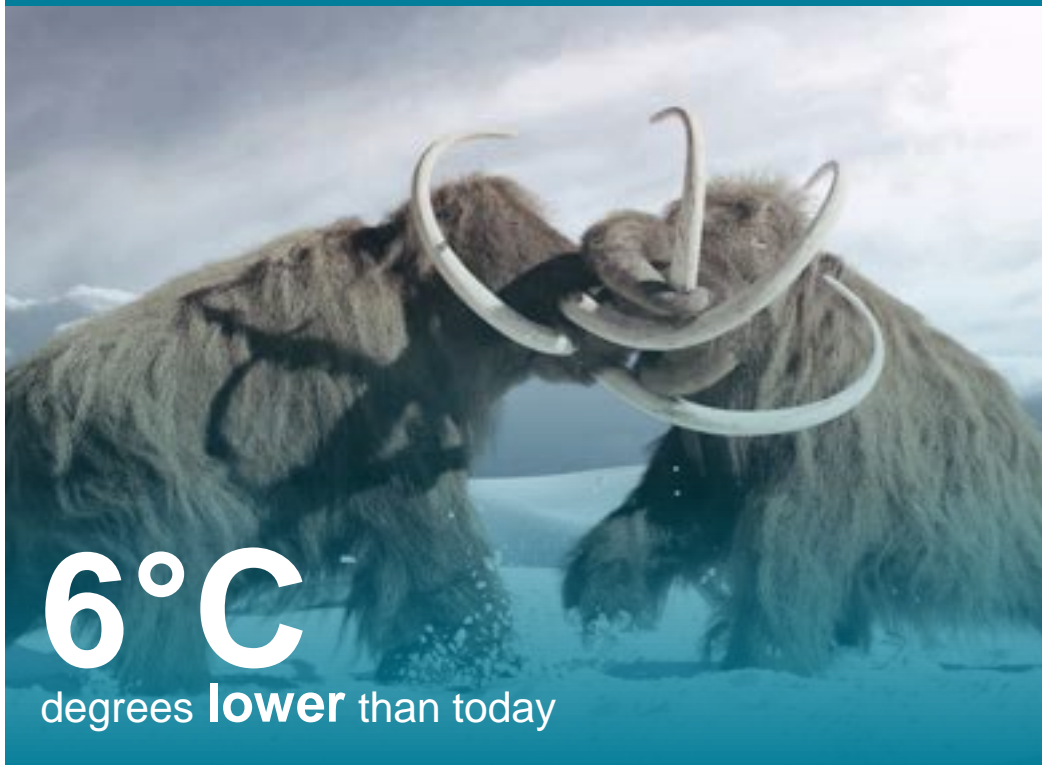

6°C

degrees **lower** than today

Age of the dinosaurs

when crocodiles could be found above the Arctic Circle

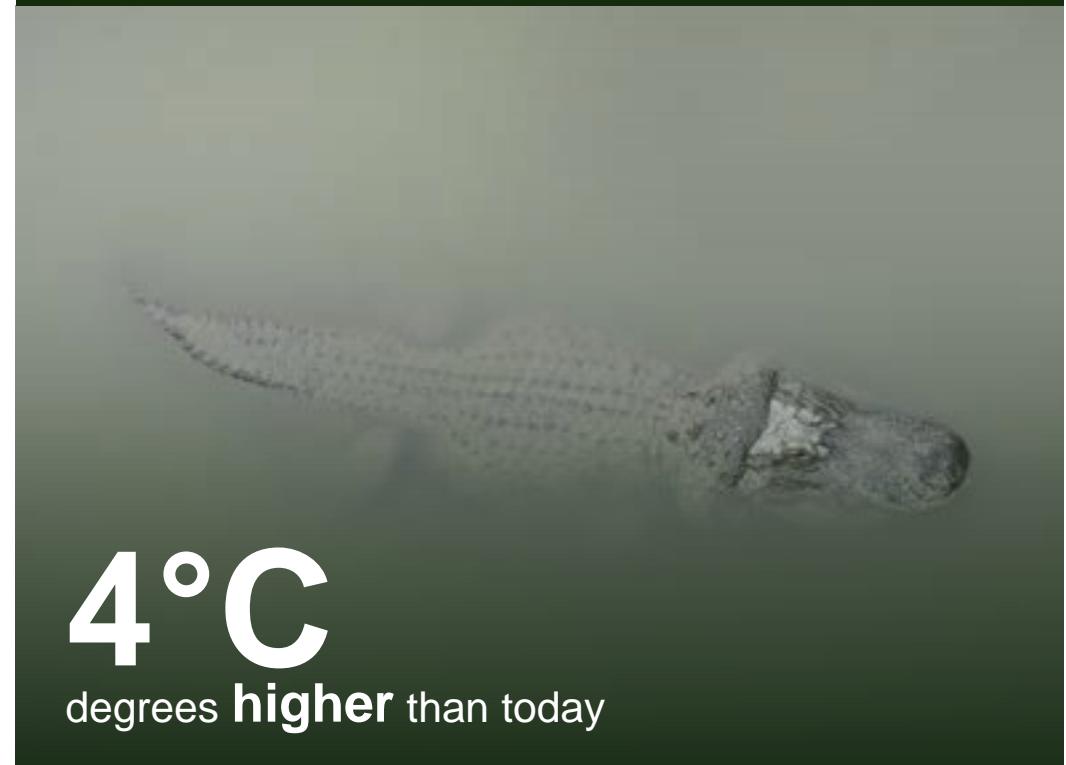

4°C

degrees **higher** than today

Warming Has Already Produced Adverse Impacts

Observed impact on ecosystems



Changes in ecosystem structure

Climate change has caused substantial damages, and increasingly irreversible losses, in terrestrial, freshwater and coastal and open ocean marine ecosystems (**high confidence**)."

Species range shifts

Hundreds of local losses of species have been driven by increases in the magnitude of heat extremes (**high confidence**), as well as mass mortality events on land and in the ocean (**very high confidence**)."

Observed impact on human systems



Water scarcity and food production

Climate change including increases in frequency and intensity of extremes have reduced food and water security, hindering efforts to meet Sustainable Development Goals (**high confidence**)."

Health and wellbeing

The occurrence of climate-related food-borne and water-borne diseases has increased (**very high confidence**). The incidence of vector-borne diseases has increased from range expansion and/or increased reproduction of disease vectors (**high confidence**)."

Human displacement

Hazards resulting from the increasing intensity and frequency of extreme weather events...are **already causing an average of more than 20 million people** to leave their homes and move to other areas in their countries each year."

In 2023, a Range of Human Activities Resulted in the Release of About 53 Billion Tons of Greenhouse Gases

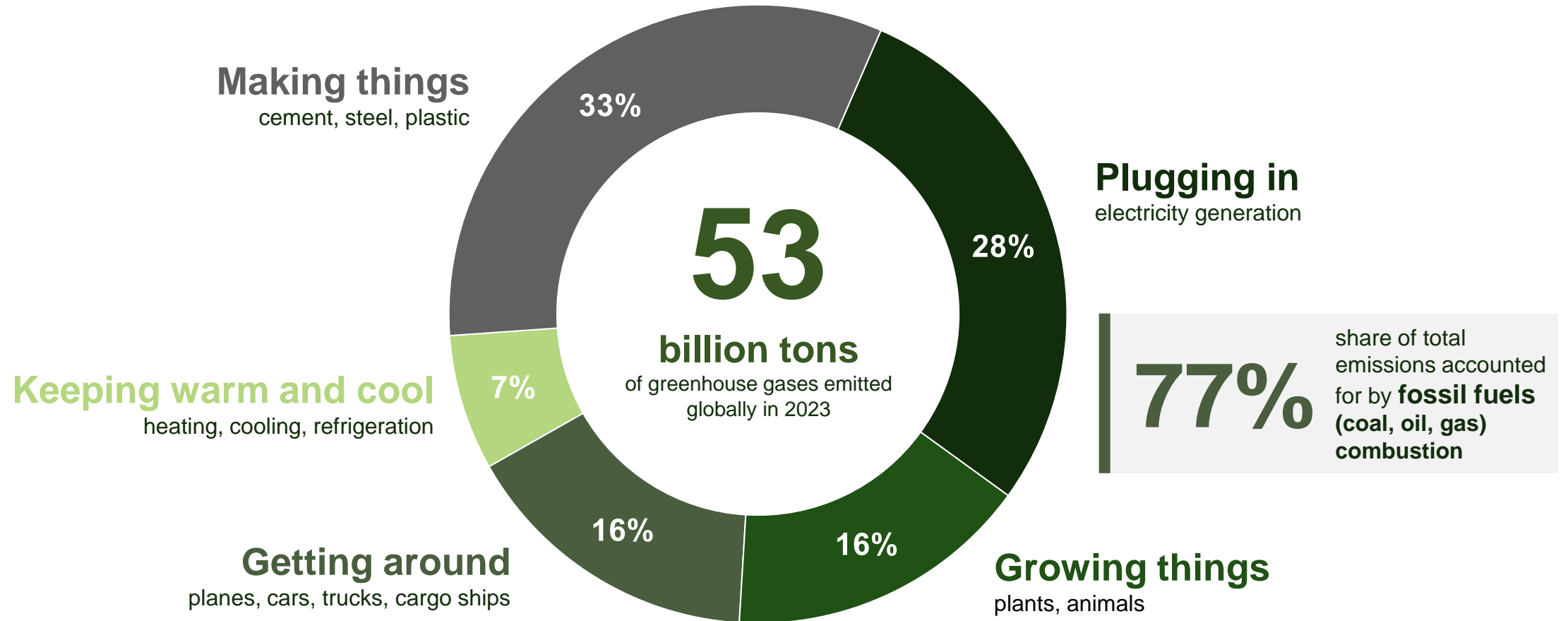

Note: Emissions measured in tons of CO₂-equivalent and include carbon dioxide, methane, nitrous oxide, and f-gases
Source: Bill Gates, *How to Avoid a Climate Disaster* (2021); EDGAR GHG emissions of all world countries, 2024 report

Nations Outside of the OECD Have Driven All of Global Anthropogenic Emissions Growth Since 1990

Gigatons of CO ₂ ¹	1990		2022		Share of 1990-2022 growth
	Emissions	% of total	Emissions	% of total	
United States	5.4	20%	5.2	12%	(1%)
EU – 27	3.7	13%	2.6	6%	(8%)
Other OECD	3.7	13%	4.8	12%	8%
Total OECD	12.8	46%	12.6	30%	(1%)
China	3.8	14%	12.4	30%	62%
India	0.8	3%	2.9	7%	15%
Other non-OECD	10.2	37%	13.6	33%	24%
Total non-OECD	14.8	54%	28.9	70%	101%
World	27.6	100%	41.5	100%	100%

Note: (1) Emissions are production-based and include emissions from energy and land-use change, measured in gigatons of CO₂
Source: Our World in Data; Global Carbon Project

But on a Cumulative Basis, the US and Europe Have Contributed Much More to Increased Atmospheric CO₂ Concentration

Cumulative global CO₂ emissions from energy and land use change

cumulative production-based emissions of carbon dioxide [CO₂] since the first year of data available, measured in million tons. This is based on territorial emissions, which do not account for emissions embedded in traded goods. Excludes non-CO₂ emissions

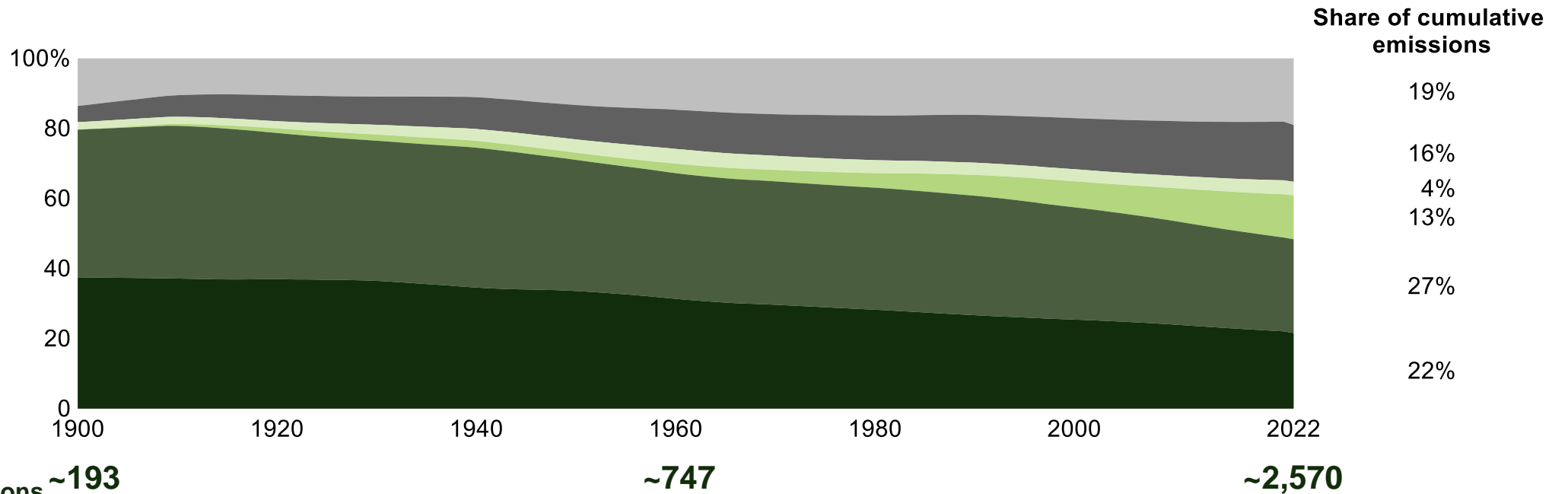

Cumulative global emissions ~193

~747

~2,570

Billions of tons since 1850

Note: Includes CO₂ emissions from fossil fuels and land use change
Source: Global Carbon Project; Our World In Data

- United States
- Europe
- Rest of the world
- China
- India
- Rest of Asia

The Top 10 Emitting Countries Account for Over Two-Thirds of Global GHG Emissions, China and the US Alone Nearly 40%

Greenhouse gas emissions by continent and country, 2022

(measured in billions of tons of CO₂-equivalent; includes non-CO₂ GHG emissions like methane)

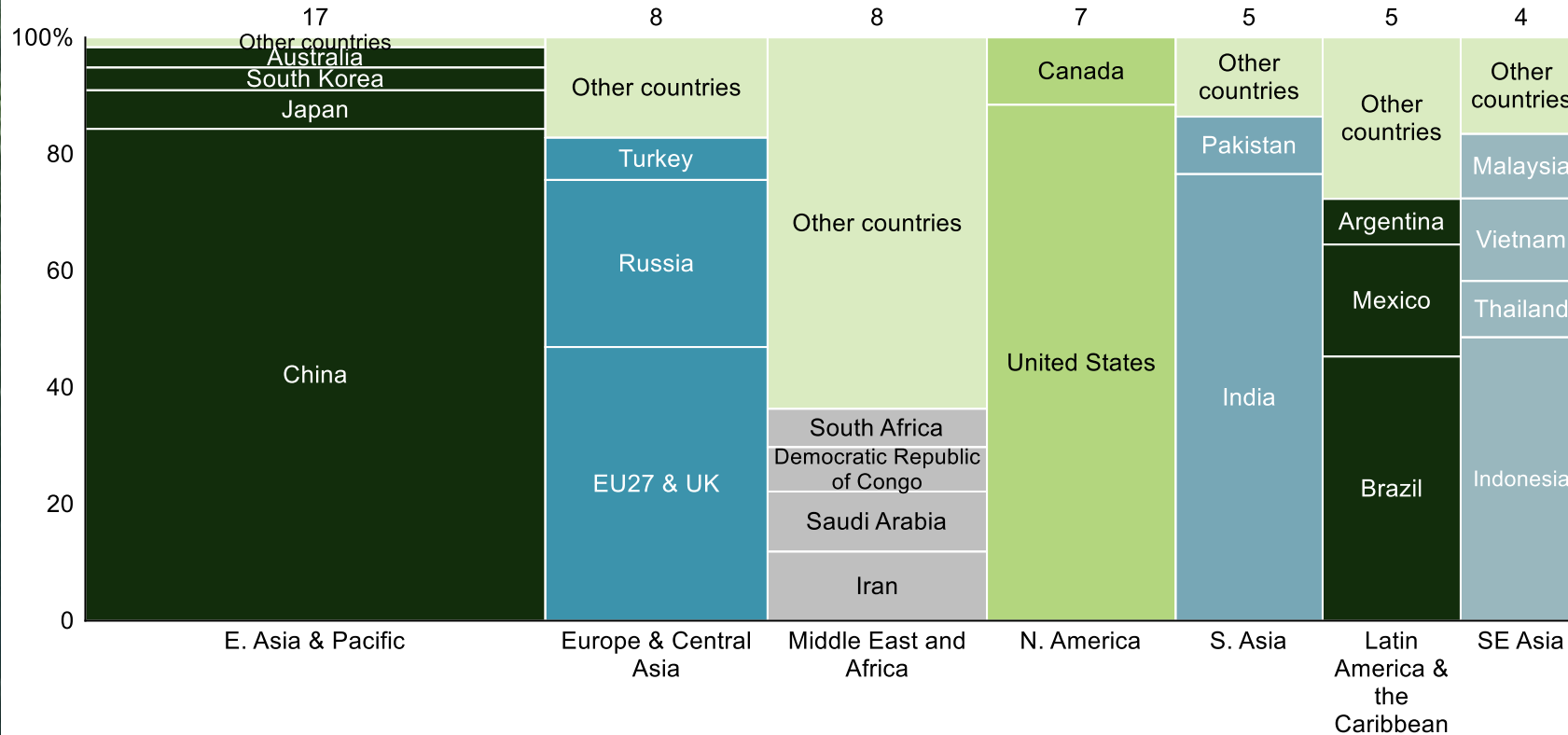

Top 10 global emitters

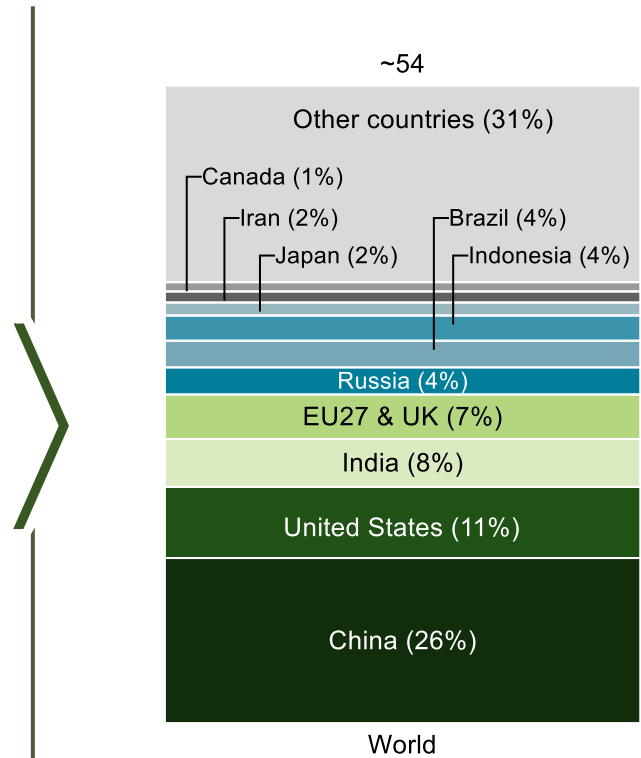

Note: * Other countries include those with <400M tons of CO₂- equivalent emissions in 2022. Emissions from international aviation and shipping included in "other countries" in right-side chart. Source: Climate Watch; Our World in Data

Continued Global Warming Presents Increasing Risks Over Time

Rising sea levels



Hot temperature extremes



Extreme precipitation events



Source: IPCC, Sixth Assessment Report (AR6), Climate Change 2021: The Physical Science Basis, paragraphs A.1.7, B.5.3, A.3.1, B.2, B.2.2, A.3.2, and figure SPM.6 (2022)

Future Risks Aren't Uniformly Distributed, With Southeast Asia and Sub-Saharan Africa Disproportionately Exposed

Share of population at high or very high risk

● Oceania ● Europe ● Asia ● Americas ● Africa

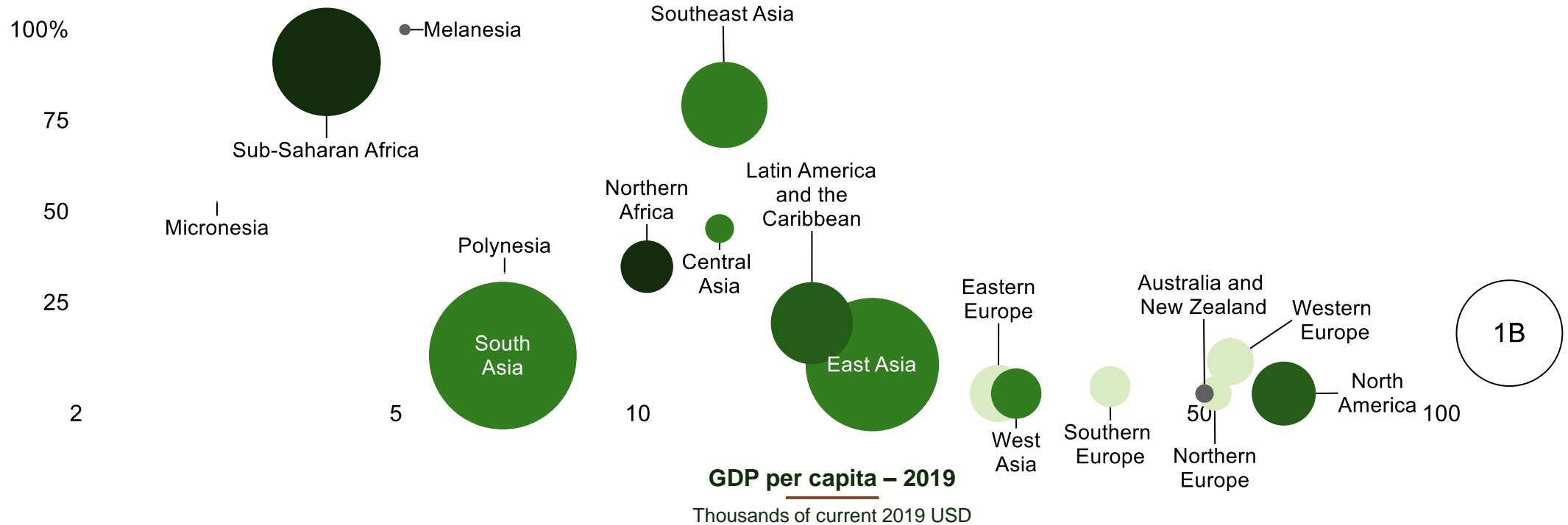

Notes: Share of population at risk based on the WorldRiskIndex, which assesses the risk of disaster as a result of natural hazards, incorporating exposure and vulnerability, and is used by the IPCC to gauge region- and country-level climate change risks; currency is adjusted for purchasing power parity; GDP per capita is shown on a logarithmic scale and is adjusted for purchasing power parity. Sources: Our World in Data; IPCC, Sixth Assessment Report; World Risk Report 2021; World Bank

Limiting Future Warming Will Require Substantial Emissions Reductions

Global primary energy demand

PETA WATT-HOURS

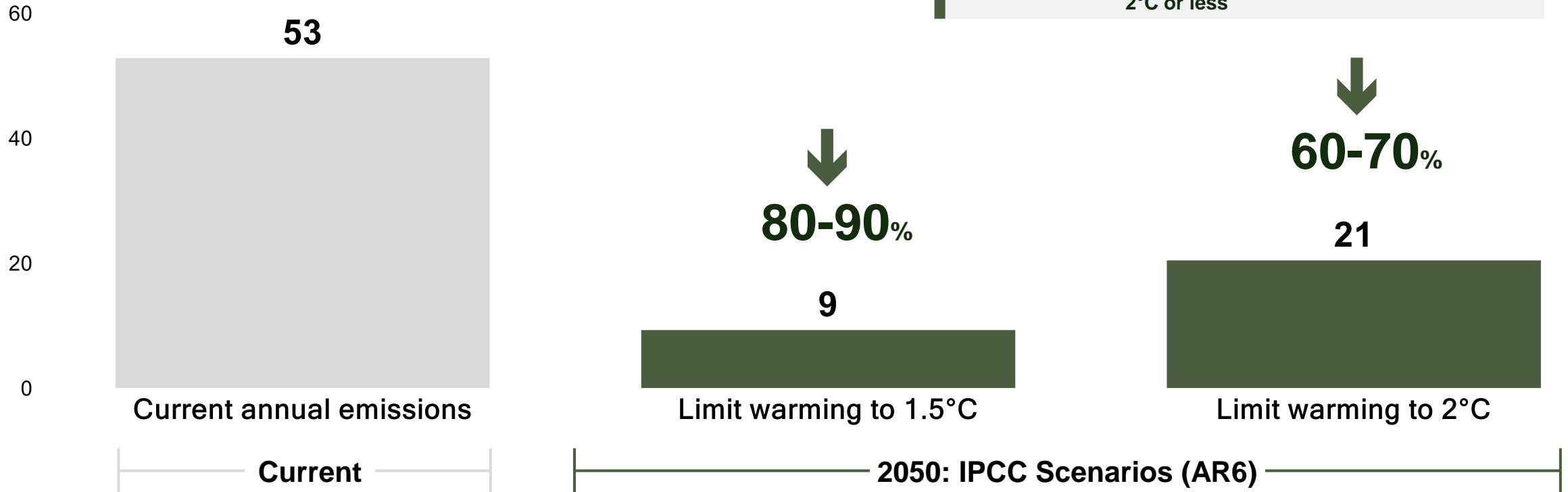

Note: ">50%" and ">67%" refer to probability of reaching scenario should emissions reduction targets be reached

Source: IPCC, Sixth Assessment Report (AR6), Climate Change 2022: *Mitigation of Climate Change – Summary for Policymakers*, Table SPM.1 (2022); Climate Action Tracker (updated Nov 2021); EDGAR *GHG emissions of all world countries, 2024 report*

1

THE DUAL CHALLENGE

This Tension Between Energy and Climate Defines the Dual Challenge



...but our largest sources of energy are the largest sources of human greenhouse gas emissions, which drive warming



Quality of life and economic growth require energy...

1 Solving Solely for Emissions and Warming Will Be Expensive and Could Jeopardize Access to Reliable, Affordable Energy

The developing world needs more energy to improve living standards, including food security



The developed world needs continued access to energy to support economic growth and living standards



► Energy access for everyone needs to be **reliable, affordable, and secure**

1 But Solving Solely for Energy Access Enhances the Risks of Climate Change

Extrapolating current trends, average temperature will exceed Paris targets by 2050 and keep rising



Extreme weather events are likely to worsen as temperatures rise, accelerating demand for action



► Energy production must be **clean and sustainable**

The Dual Challenge: Expand Affordable, Reliable, Secure Energy Access and Reduce Emissions

Energy Will Grow

Global primary energy demand (petawatt-hours)

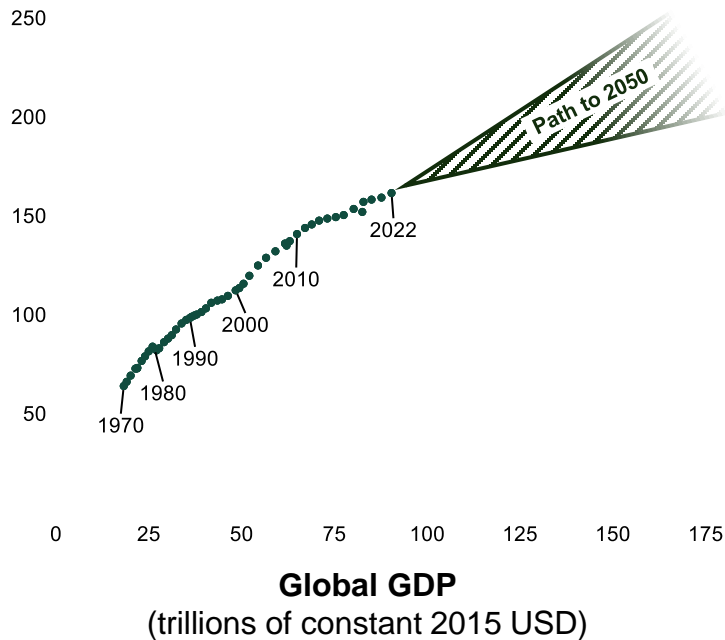

Emissions Must Decline

Global annual greenhouse gas emissions (gigatons of CO₂-equivalent)

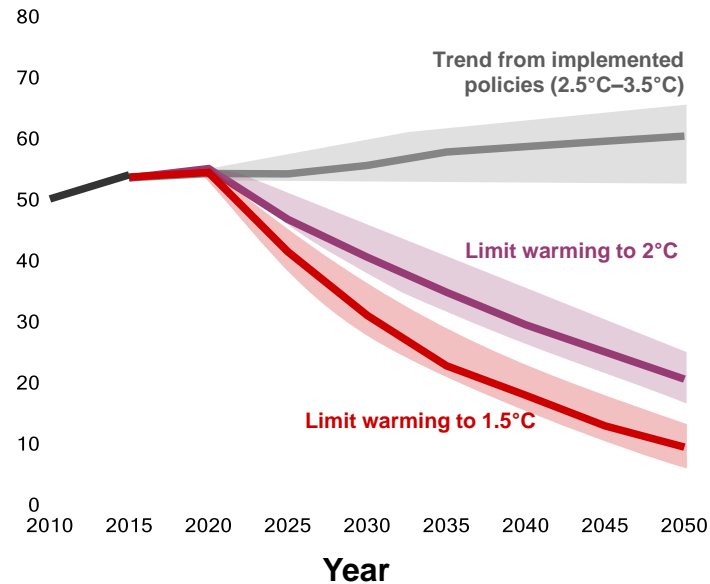

The Dual Challenge

Global CO₂e emissions (gigatons of CO₂e)

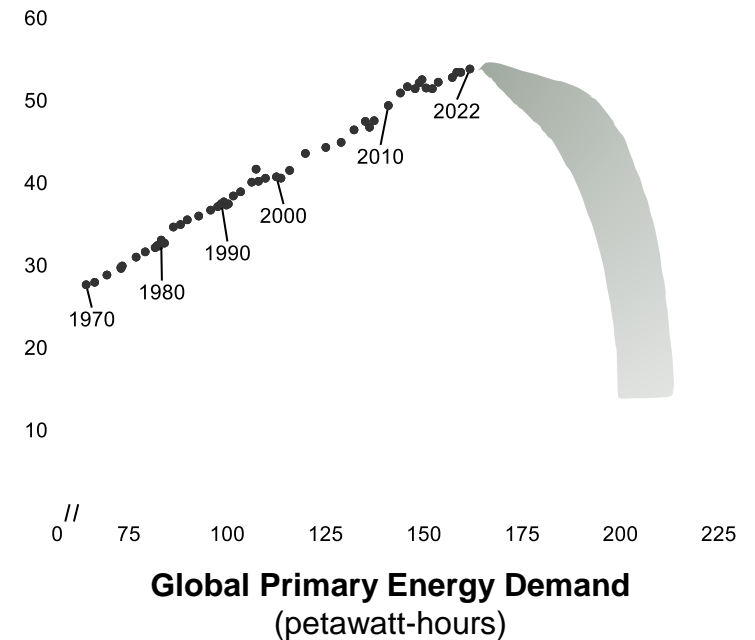

Note: Warming figures in middle-side emissions chart are relative to the preindustrial period and reflect projected warming level by 2100 in each scenario; bold lines in emissions chart represent median estimate, and shaded regions reflect a range from the 25th to 75th percentile. Emissions in right-side chart reflect global CO₂ emissions inclusive of land use change.

Sources: IPCC, Sixth Assessment Report; World Bank; Our World in Data

This is the World's Most Difficult Problem

Avoiding the worst risks of climate change requires us to significantly reduce anthropogenic greenhouse gas emissions.

30-40B metric tons

decline in annual GHG emissions (~60-70% reduction) needed by 2050 to limit warming to 2°C by 2100

Achieving this would necessitate substantial, rapid changes to our energy system.

77%

share of our primary energy derived from fossil fuels (oil, gas, and coal) in 2021

The physical scale of what must be addressed or augmented is enormous.

15B metric tons

the mass of oil, gas, and coal our energy production and processing infrastructure handles annually today

A significant global industrial mobilization is required if we hope to achieve our goals

Solving it Will Require Different Measures for Developed vs. Developing Countries

~3 billion people
Birth rate: ~25/1,000 people

~3.5 billion people
Birth rate: ~15/1,000 people

~1 billion people
Birth rate: ~11/1,000 people

CO₂ emissions per capita, 2019

Consumption-based emissions (i.e., Adjusted for trade), measured in tons per person

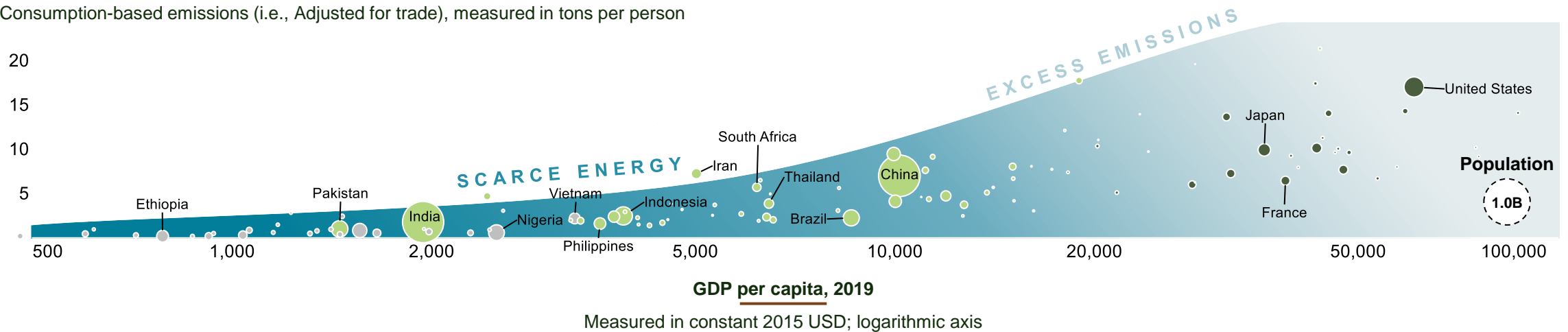

Low-income developing countries

How do we lift countries out of energy poverty in a low-carbon way without erecting barriers to economic development? (i.e., without following the previous trajectory of the Advanced countries)

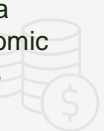

Emerging countries

How do we support countries in industrialization and accessing low cost clean energy?



Advanced countries

How do we reduce emissions while maintaining high quality of life and growth?

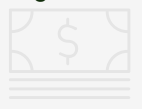

Note: GDP is adjusted for purchasing power parity

Source: Max Roser, "The world's energy problem", Our World in Data; Switch On (2020); World Bank; Global Carbon Project; IMF; UN World Population Prospects 2019

1 Achieving “Clean” Without Compromising “Reliable, Affordable, and Secure” in Our Energy Supply is the Essence of it



Deliver energy globally...



We need to deliver affordable, reliable, secure energy for the entire world before 203X.

...while significantly reducing emissions...

We need to dramatically reduce emissions to mitigate the worst risks of climate change.

...to maximize human flourishing

The aim is to enhance the wellbeing of humans everywhere.

Our Starting Point: Fossil Fuels Remain the World's Chief Source of Energy

Global primary energy consumption by source

PETAWATT-HOURS

200

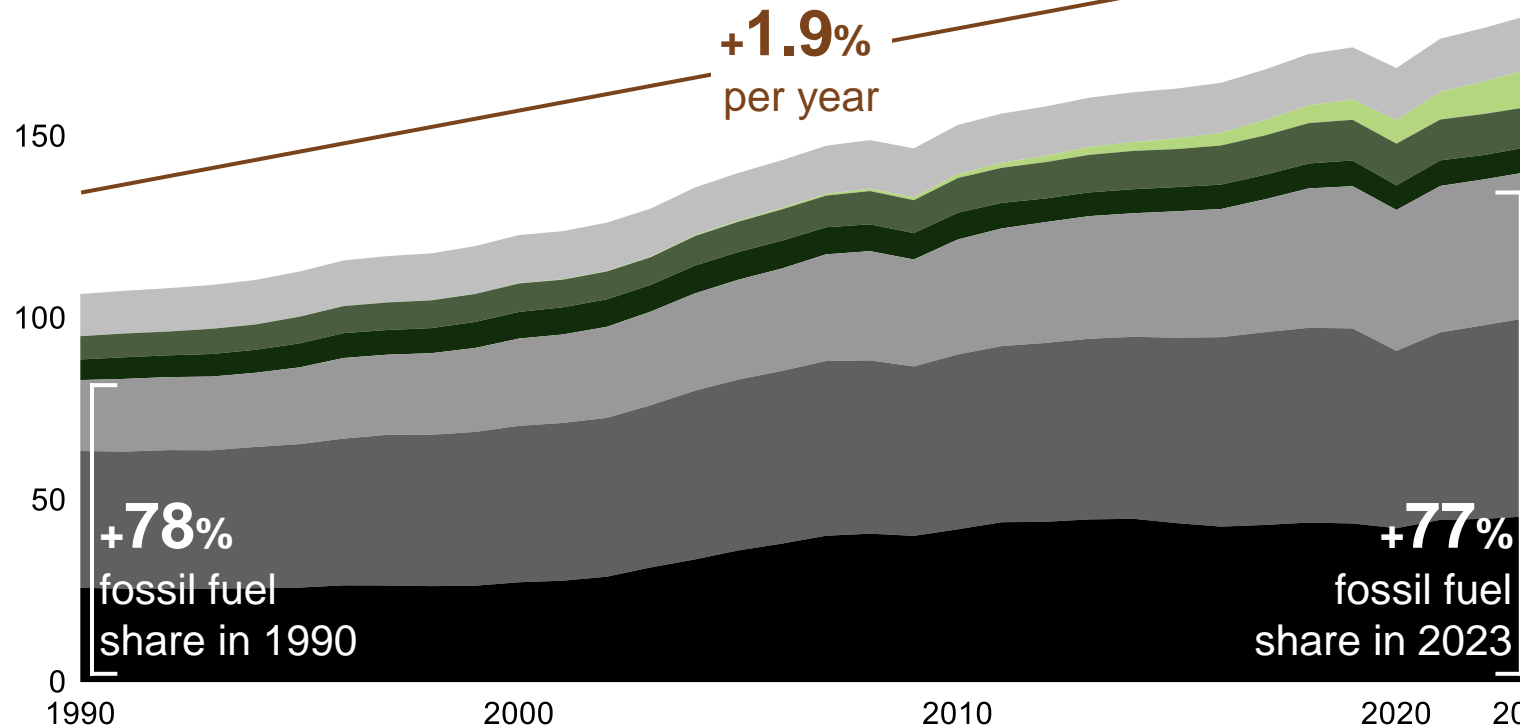

Percent of
total 1990

Percent of
total 2023

Share of
1990-2023
demand growth

Percent of total 1990	Percent of total 2023	Share of 1990-2023 demand growth
11%	8%	4%
0%	6%	13%
6%	6%	6%
5%	4%	1%
18%	22%	27%
35%	30%	22%
24%	25%	26%

Coal Oil Gas Nuclear Hydro Wind & Solar Other*

Note: * Other includes traditional biomass, biofuels, and other renewables
Source: Our World in Data *Energy Mix*

1 The Scale of What Must be Replaced or Abated in Our Existing Energy System Is Immense

15 billion metric tons

Mass of fossil fuels (oil, gas, and coal) extracted each year, the energy equivalent of more than **230 million barrels of oil per day**, or about **1,500 kg of oil per year for every person on the planet.**¹



4,400 gigawatts

Fossil fuel electrical generation capacity globally, which is responsible for **61% of world electricity production**—and about **one-quarter of global greenhouse gas emissions.**³



1.6 billion internal combustion engines

Approximate number of **internal combustion engines** in use around the world in cars and trucks, **almost all of which run on petroleum products like gasoline and diesel.**²



6 billion metric tons

Total mass of cement and steel produced globally. Production of these critical products **added more than 7 billion tons of CO₂ to the atmosphere** in 2019.⁴

Source: (1) EIA; IEA; BP; Vaclav Smil, *How the World Really Works*. (2) International Journal of Engine Research, *The future of the internal combustion engine vehicle*. (3) [Ember](#). (4) Portland Cement Association; World Steel Association; IEA

This Will Take Time—History Suggests that Turning Over Even a Quarter of the Global Energy System Takes Decades

Years until supplying 25% of global primary energy supply

SHARE OF GLOBAL PRIMARY ENERGY SUPPLY

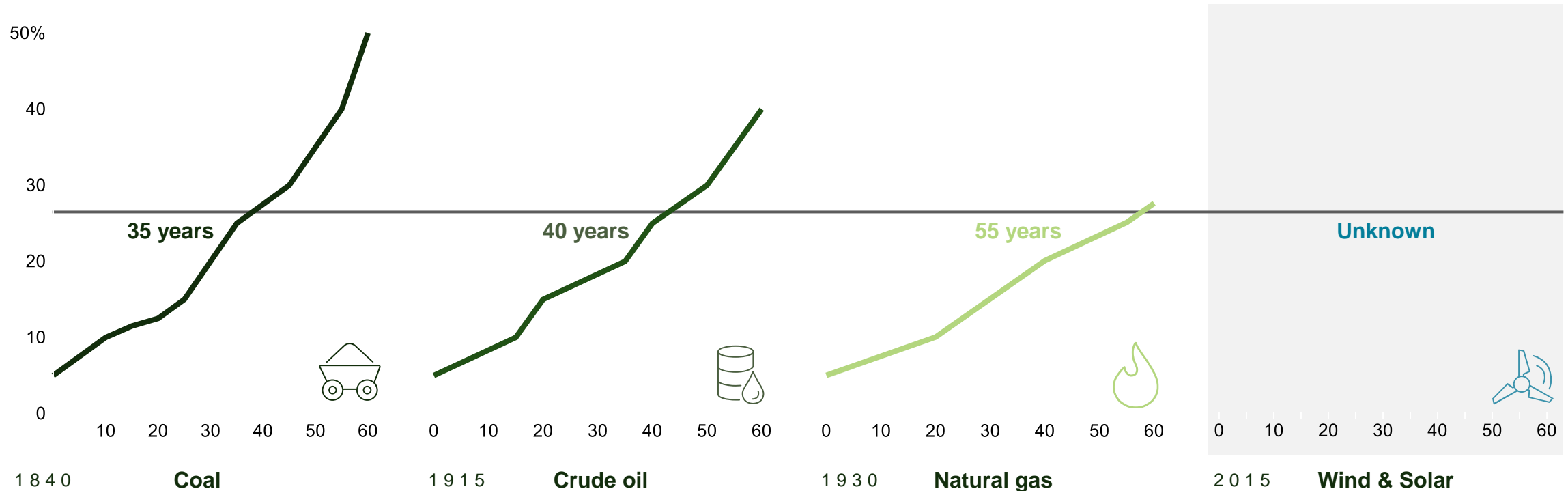

Note: Based on time from 5% to 25% of global energy supply
 Source: Vaclav Smil, *Energy Transitions: Global and National Perspectives* (2017)

1

We Have Made Progress on Emissions—But Still Have Work to Do

Global temperature increase in 2100

By year of estimate based on implemented policies (median)

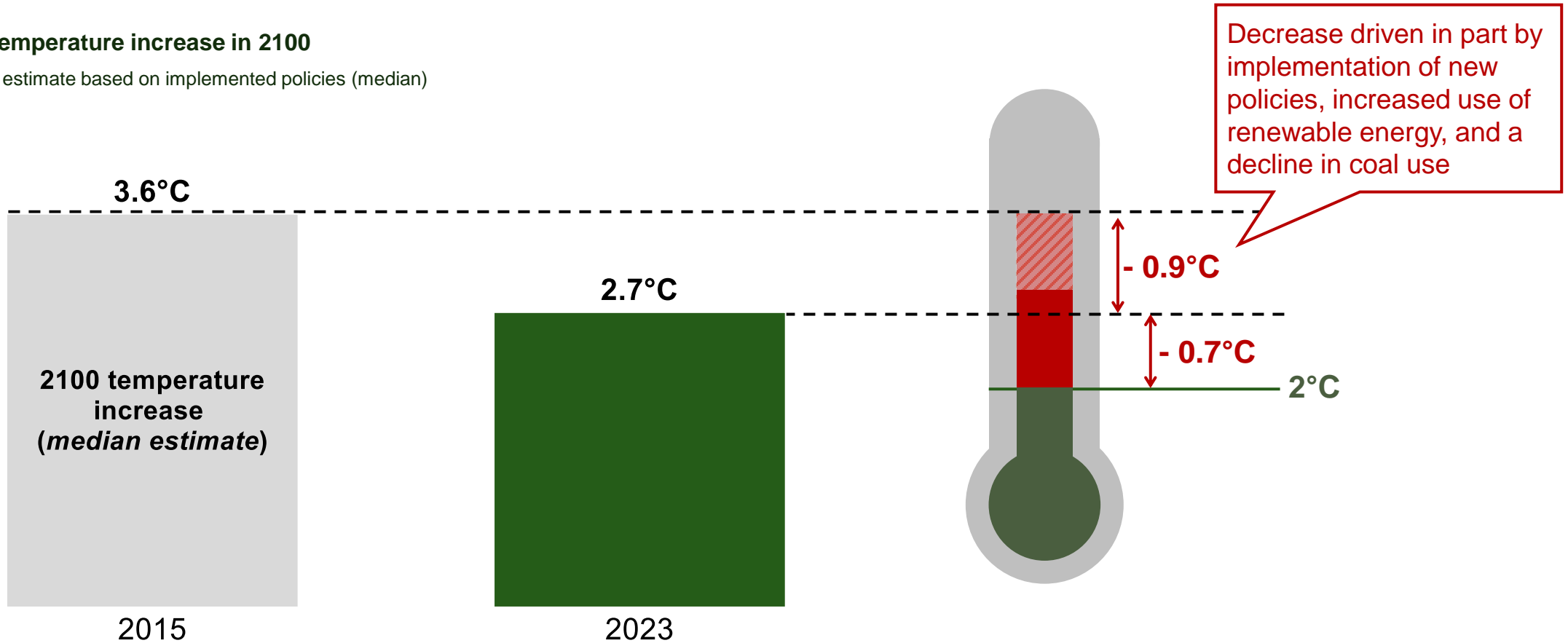

Note: Temperature estimates reflect end-of-century warming above the pre-industrial average based on implemented policies
 Source: Climate Action Tracker, "Paris Agreement turning point", December 2020

Most of the World is Still Climbing the Energy Ladder

Primary energy consumption per capita

MEGAWATT-HOURS

- China
- EU27 and UK
- United States
- Southeast Asia
- Japan
- Middle East and North Africa
- South Korea
- Sub-Saharan Africa
- India

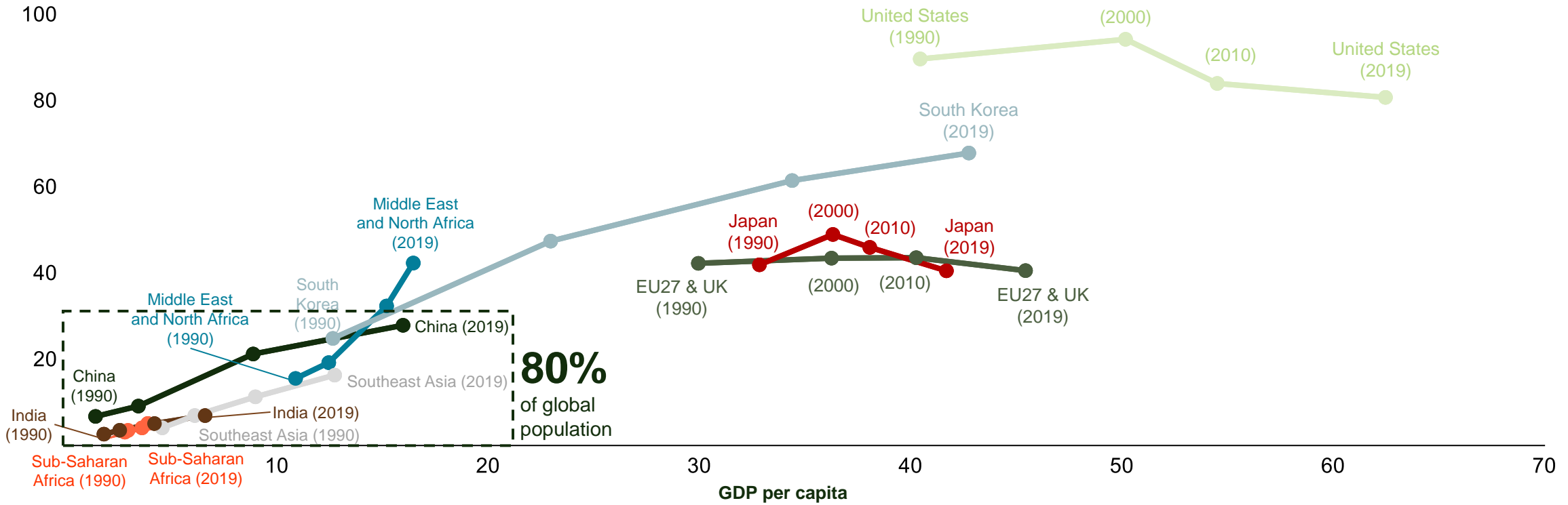

Thousands of constant 2017 USD, adjusted for purchasing power parity

Sources: Our World in Data; World Bank; BP Statistical Review of World Energy, 2022; EIA

1

Achieving Net Zero Emissions by 2050 Amidst Demographic and Economic Growth Would Require Unprecedented Change

Global CO₂e emissions¹
(gigatons of CO₂e)

Demographic and economic backdrop for 2022-2050 period

1.7B projected population growth²

>2X projected real GDP growth, or 2.6% p.a.³

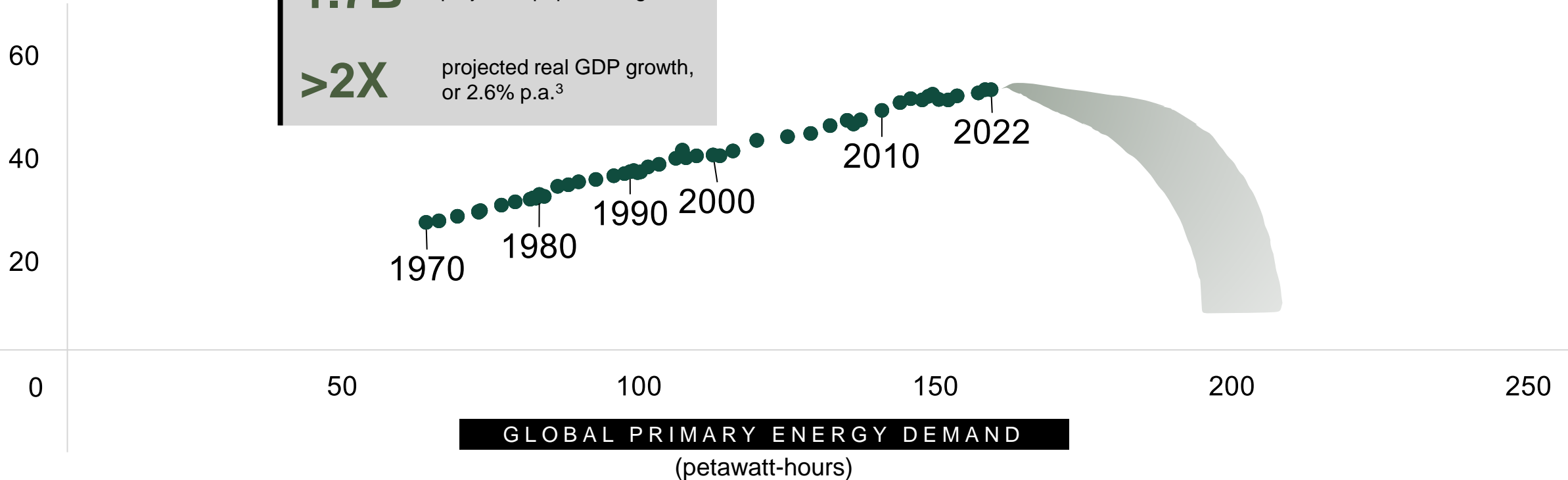

Note: (1) CO₂e emissions include land use change; (2) UN median fertility scenario; (3) GDP expressed in 2022 USD in purchasing power parity terms via IEA and UN
Source: IEA World Energy Outlook 2023; Our World in Data; UN Trade and Development

1

What Will It Take to Bend the Curve Amidst Expected Demographic and Economic Growth?

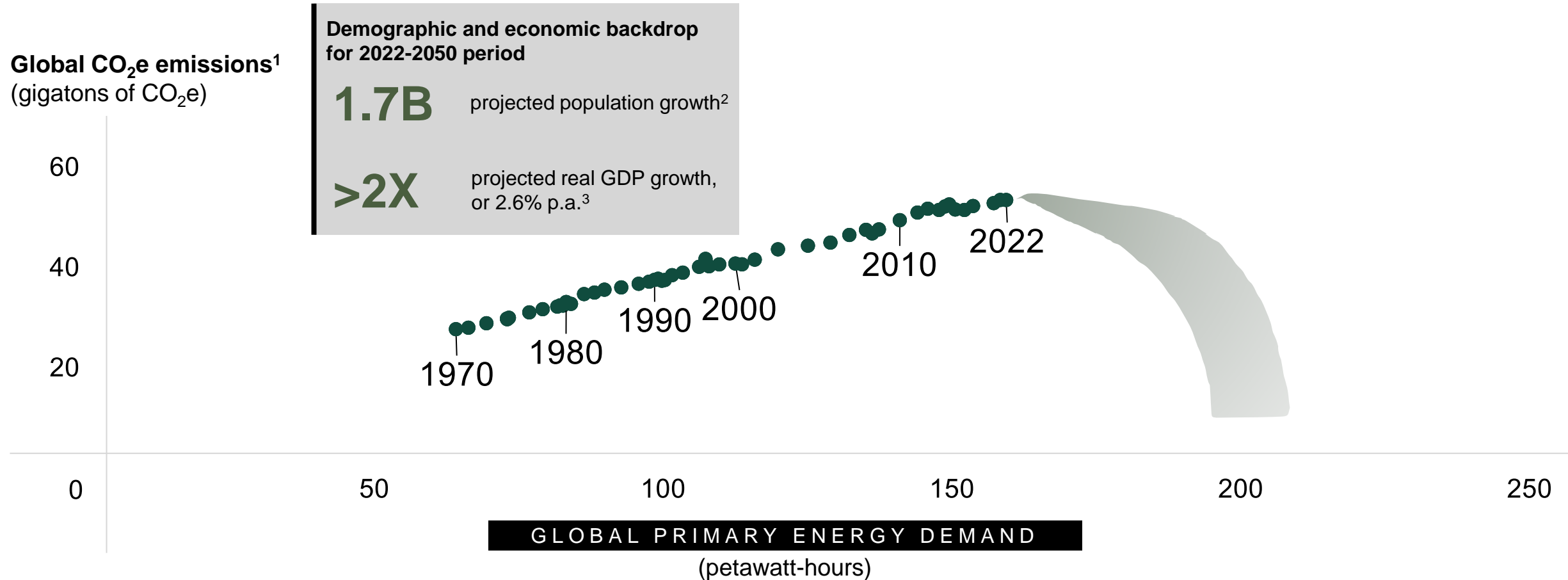

Note: (1) CO₂e emissions include land use change; (2) UN median fertility scenario; (3) GDP expressed in 2022 USD in purchasing power parity terms via IEA and UN
Source: IEA World Energy Outlook 2023; Our World in Data; UN Trade and Development

[Click to learn more about our emerging solutions](#)

Confronting the Dual Challenge: Emerging Solutions

September 2023

Agenda

An aerial photograph of a wind turbine in a lush green field. The turbine is white with three blades, one of which is pointing towards the top right. The field is divided into sections by thin lines, possibly roads or irrigation channels. The overall scene is bright and clear.

01

OpenMinds
and the Dual
Challenge:
Executive
Summary

02

**Energy: Uses,
Sources, and
Outlook**

03

Climate
Change:
Fundamentals
and Possible
Trajectories

04

Reality Check:
Where We Are
Today

05

The Dual
Challenge:
Headwinds
and Tailwinds

Energy: Uses, Sources, and Outlook



- Affordable and reliable energy underpins modern civilization and enables longer, healthier lives
- Fossil fuels unlocked tremendous progress in global population, productivity, and GDP over the last century and today account for roughly 80% of the world's total energy supply
- Our dependence on fossil fuels has not changed materially in three decades (despite a slight shift to wind & solar, which make up 3% of the world's current energy supply), with total energy consumption growing about 60% since 1990
- While energy usage *per dollar of GDP* declined in most countries over the last 30 years, overall energy usage *per capita* grew as developing economies, particularly China, advanced
- Despite this growth, a meaningful share of the world still lacks access to sufficient energy, and future population growth will be concentrated in these low-energy regions
- It is a good thing for energy-driven quality of life to improve for these populations, but the energy supply must be both affordable and reliable to unlock those improvements
- Moreover, in a world of increased geopolitical tension (and perhaps deglobalization), energy security at the national level will rise in prominence—and will shape the energy transition differently in different regions

Primary energy demand will very likely continue rising into the future as GDP grows and living conditions improve, and affordability, reliability, and security of energy supply will be key concerns. To the extent this increasing demand is met by fossil fuels (unabated), greenhouse gas emissions will continue to grow as well.

In Physical Terms, Energy is the Capacity for Doing Work and Can Be Measured in Joules or Watt-Hours

en·er·gy
 \ 'e-nər-jē \

in physics, the **capacity for doing work**, measured in joules

1
joule

Approximate amount of energy needed to lift a smartphone 15 inches, or 40 cm, off the table

6×10^{20}
joules

Total amount of energy used by the world in 2019

3,600
joules

Amount of energy in one watt-hour, a common measure of electricity usage

Energy Enables Virtually Everything We Do



2

Daily Activities and Products Have a Range of Energy Needs



Keep a lightbulb
on for one hour

100,000
joules



Use a gallon of
gasoline

100 million
joules



Grow a metric ton
of wheat

10 billion
joules



Power New York
City for a day

100 trillion
joules

Note: All values are order of magnitude estimates. Energy usage for lightbulb based on 40-Watt bulb; energy usage for gallon of gasoline based on EPA standard; energy usage for wheat includes human labor, fuel for agricultural machinery, fertilizer, chemicals, irrigation, and other operations; energy consumption for New York assumes 144 gigawatt-hours per day on average

Source: Department of Energy; Bill Gates, How to Avoid a Climate Disaster (2021); EPA; World Journal of Agricultural Sciences; IEA; New York Building Congress

Energy Has Played a Crucial Role in Economic and Human Development

Global energy consumption

PETAWATT-HOURS

Global GDP

TRILLIONS OF CONSTANT 2017 INTERNATIONAL USD, PPP ADJUSTED

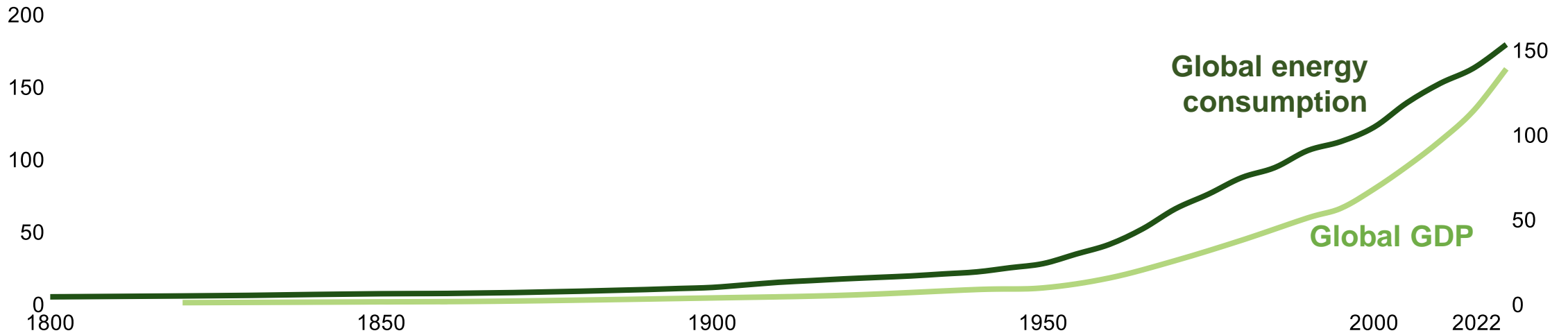

World population

1.0B



8.2B



Average life expectancy

29yrs.



73yrs.



Note: GDP is adjusted for purchasing power parity. Sources: BP Statistical Review of World Energy 2021; Vaclav Smil, *Energy Transitions: Global and National Perspectives*, 2017; Maddison Project Database, version 2020. Bolt, Jutta and Jan Luiten van Zanden (2020), "Maddison style estimates of the evolution of the world economy. A new 2020 update"; World Bank; Our World in Data

Energy Consumption is Highly Correlated With Economic Progress—and There is Still Considerable Inequality

Primary energy consumption per capita – 2019

Megawatt-hours

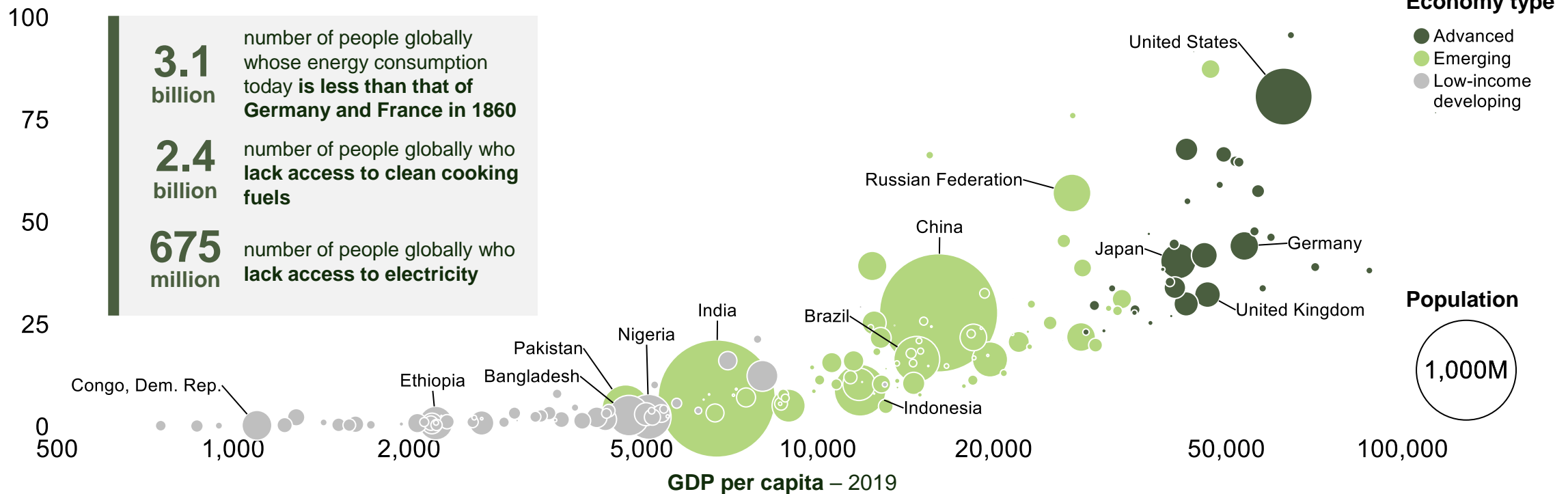

Source: Our World in Data; World Bank; IMF; Global Carbon Project; Vaclav Smil, *How the World Really Works*

Energy Underpins Human Well-Being

Human development Index – 2019

The HDI is a summary measure of key dimensions of human development: a long and healthy life, a good education, and having a decent standard of living

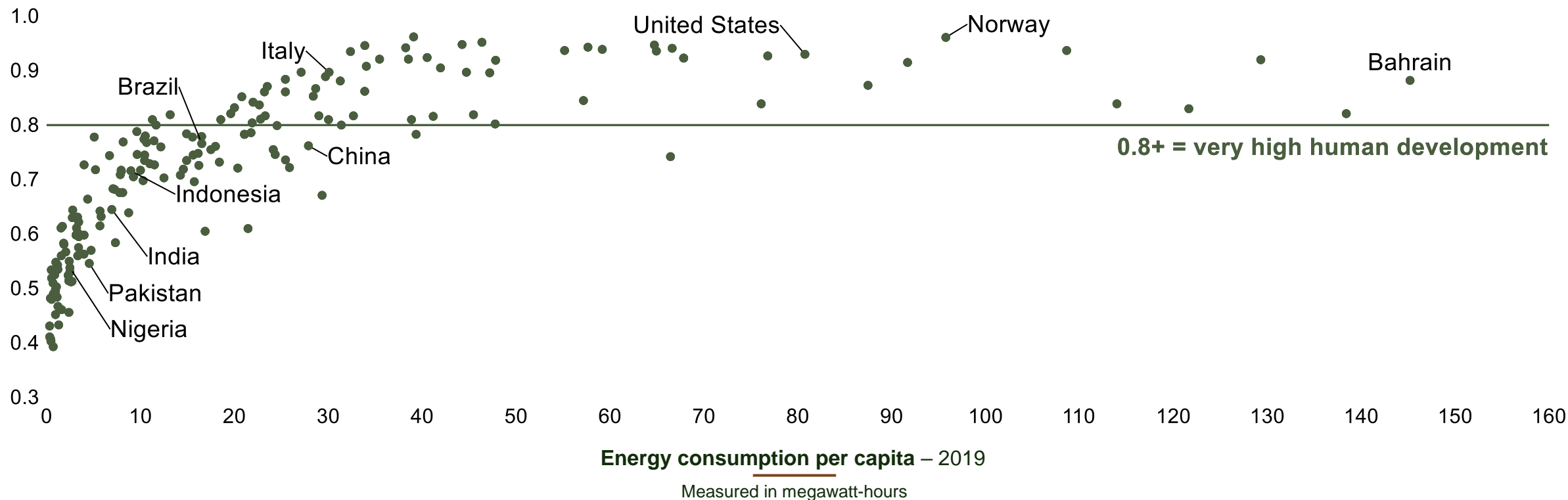

Source: Our World in Data; Center for Global Development; BP Statistical Review of World Energy, 2021; EIA

For Example, Those Lacking Modern Energy Access Die at Higher Rates from Indoor Air Pollution

Indoor air pollution death rate 2016

Measured per 100,000 individuals

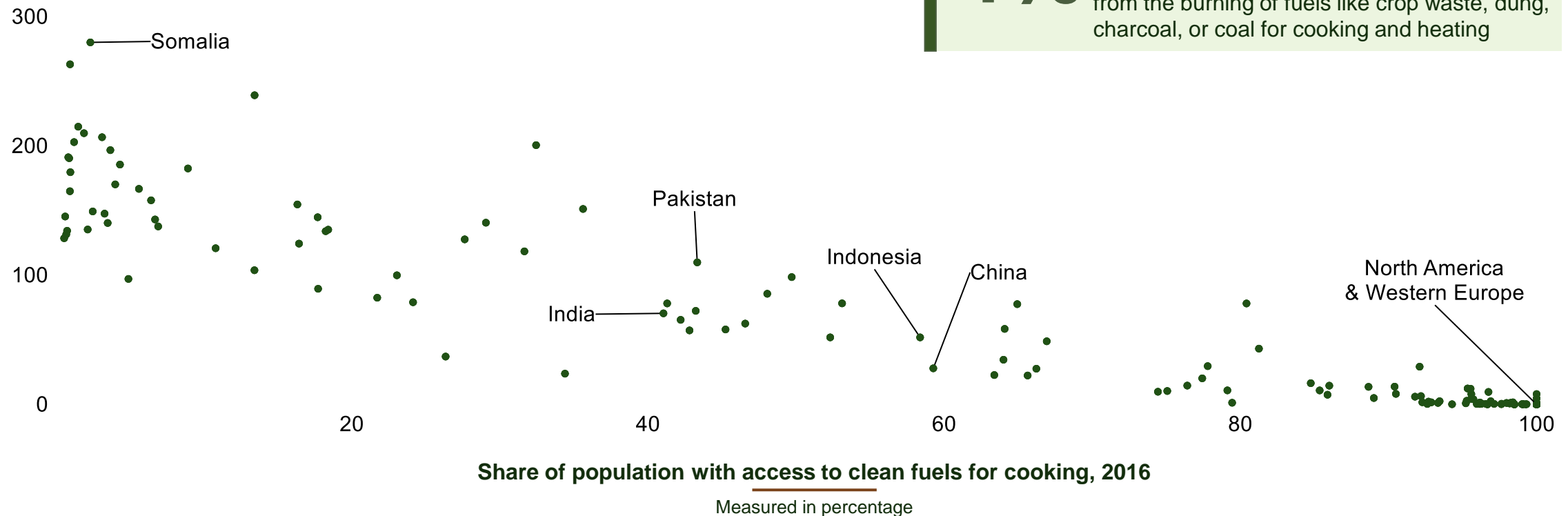

Despite Progress, the World Needs More Energy

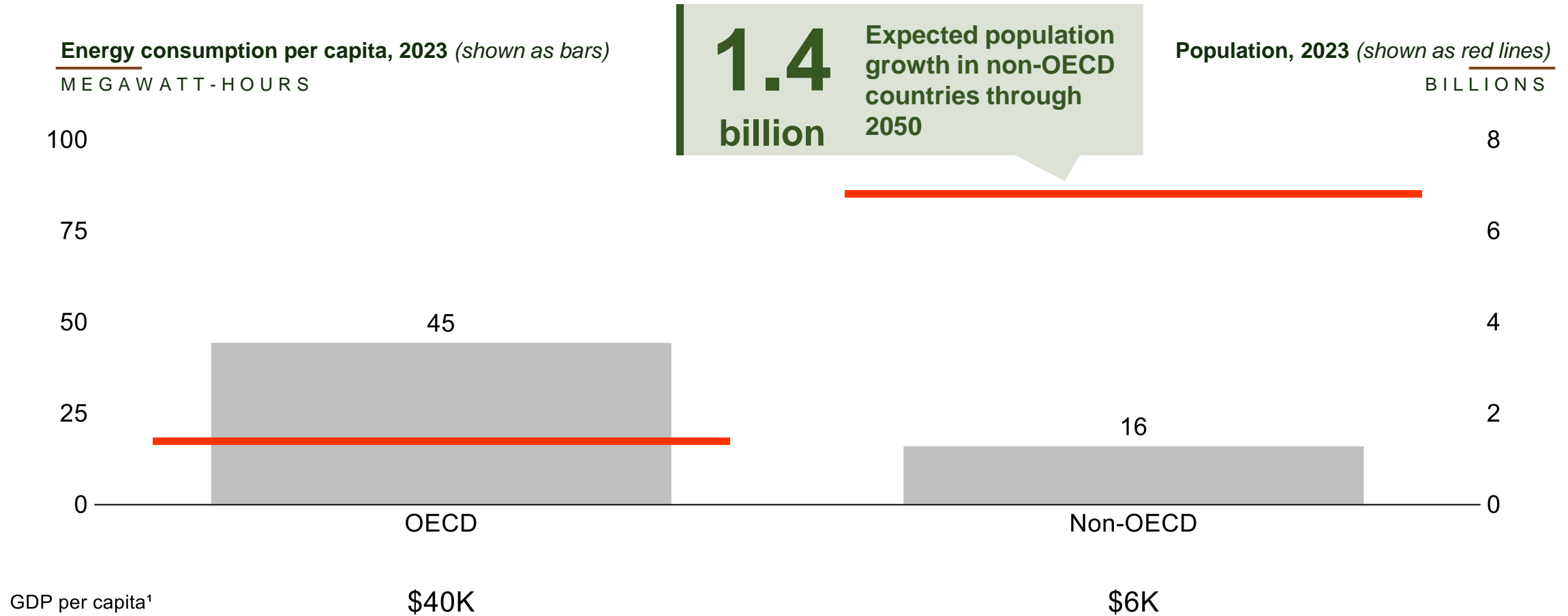

Note: (1) GDP per capita is adjusted is measured in 2015 USD. Source: World Bank; Exxon Global Energy Outlook 2024; IEA [Growth in Developing Countries](#)

2

Primary Energy Demand is About 173 Petawatt-Hours Per Year, or the Equivalent of 300 Million Barrels of Oil Per Day

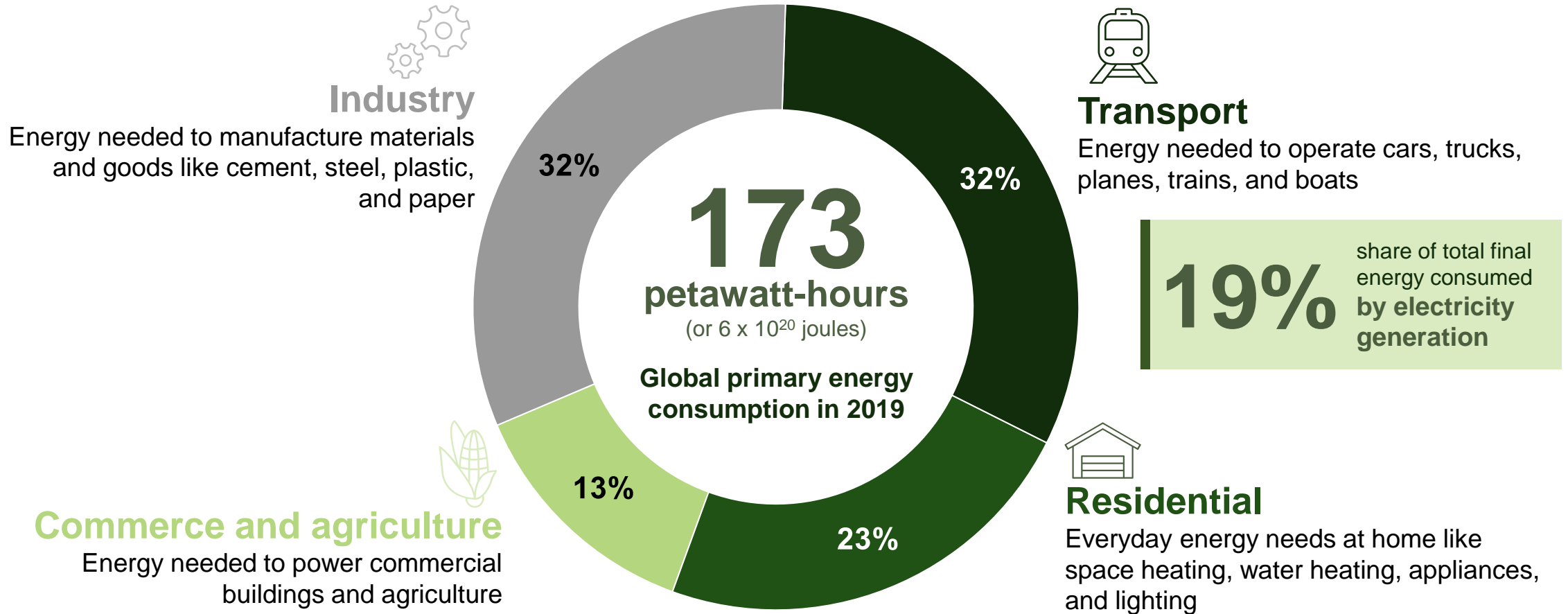

Note: Usage mix is based on IEA estimates (net energy content and excludes energy lost to produce water vapor during combustion); total usage, including losses, based on EIA and XOM
 Source: Our World in Data; IEA, Total Final Consumption (TFC) by Sector, 2019; BP Statistical Review of World Energy, 2021; ExxonMobil 2021 Outlook for Energy

2

In Terms of Physical Labor, the Amount of Energy Consumed Globally Per Capita is Enormous

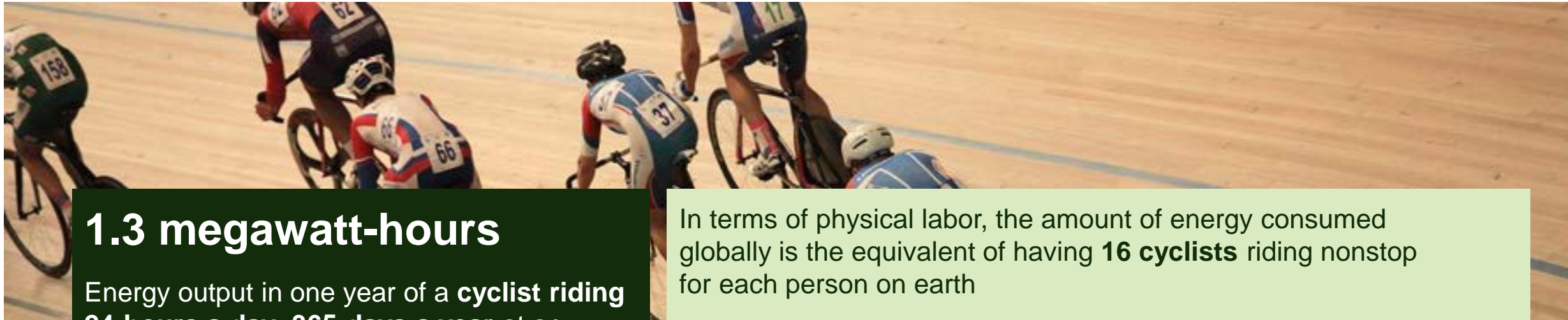

1.3 megawatt-hours

Energy output in one year of a **cyclist riding 24-hours a day, 365-days a year** at an average power output of 150 watts

(Tour de France riders average 230-250 watts and can sustain a maximum of about 350-400 watts for one hour)

In terms of physical labor, the amount of energy consumed globally is the equivalent of having **16 cyclists** riding nonstop for each person on earth

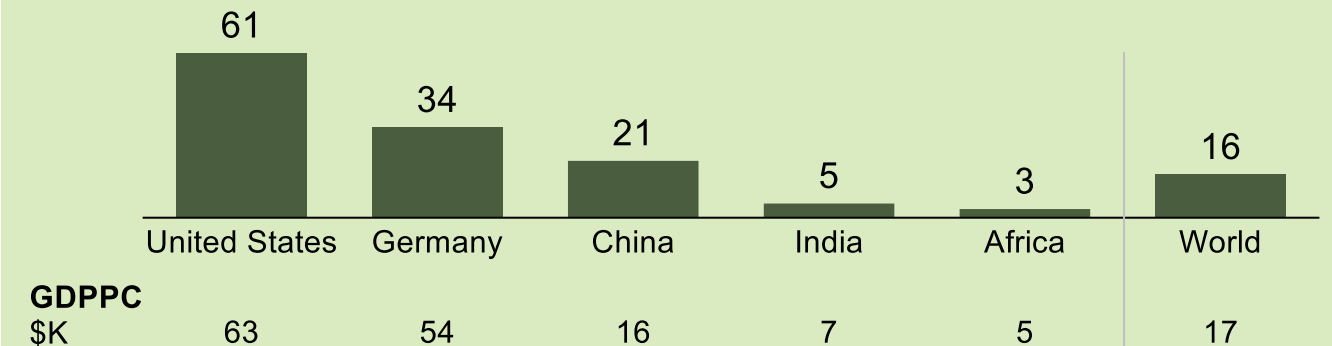

Note: * GDP measured in thousands of real PPP-adjusted 2017 USD
 Source: Our World in Data; World Bank; BP Statistical Review of World Energy, 2021

Almost 80% of Primary Energy Supplied Globally Derives From Fossil Fuels (i.e., Coal, Oil, and Gas)

Global primary energy demand by source 2023

PETAWATT-HOURS

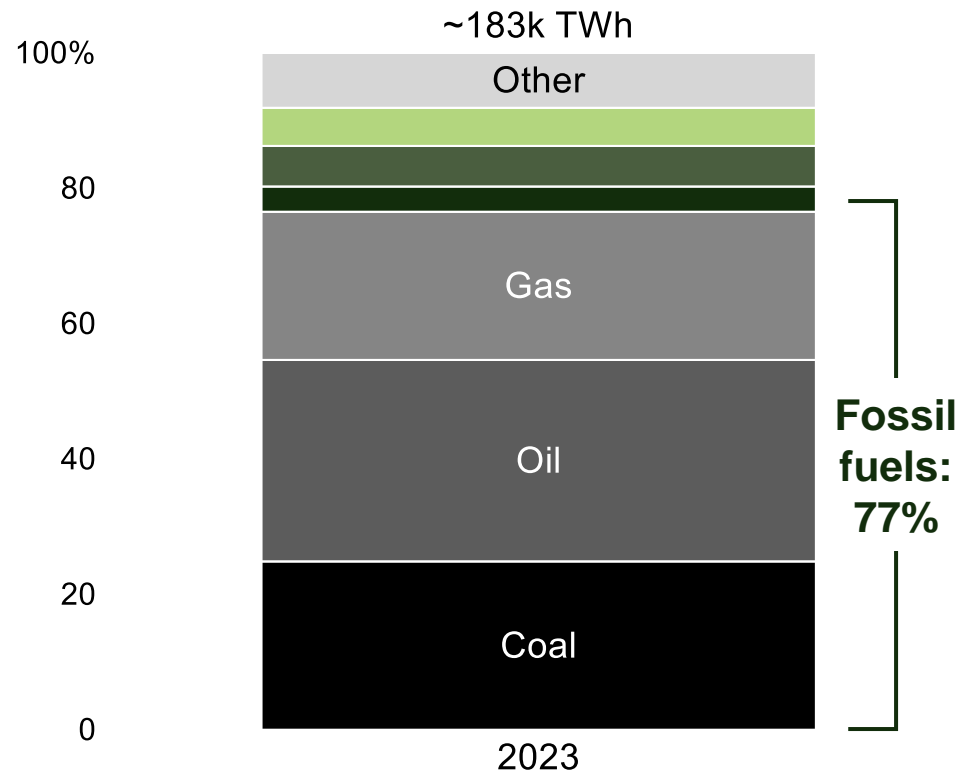

Note: "Other" includes traditional biomass (i.e., burning wood), other renewables, and biofuels
 Source: Our World in Data [Energy Consumption](#)

2 The Fossil Fuel Infrastructure That Provides Most of Our Energy Is Enormous in Its Scale and Was Built Over a 150+ Year Period

15 billion metric tons

Mass of fossil fuels (oil, gas, and coal) extracted each year, the energy equivalent of more than **230 million barrels of oil per day**, or about **1,500 kg of oil per year for every person on the planet.**¹



\$813 billion

Global fossil fuel infrastructure capital investment **in a single year (2021)**, inclusive of up-, mid-, and downstream oil & gas, coal supply, and fossil fuel power generation.³



1.2 million kilometers

Combined length of oil & gas pipelines globally, **enough to circle the earth 29 times.**²



1846

The year the world's first giant oilfield opened in Baku, Azerbaijan, **marking the beginning of the modern oil era.**⁴ Oil & gas infrastructure has been continuously developed since then.

Energy Demand Has Grown Steadily Over Time and Fossil Fuels Remain the World's Chief Source of Energy

Global primary energy consumption by source

PETAWATT-HOURS

200

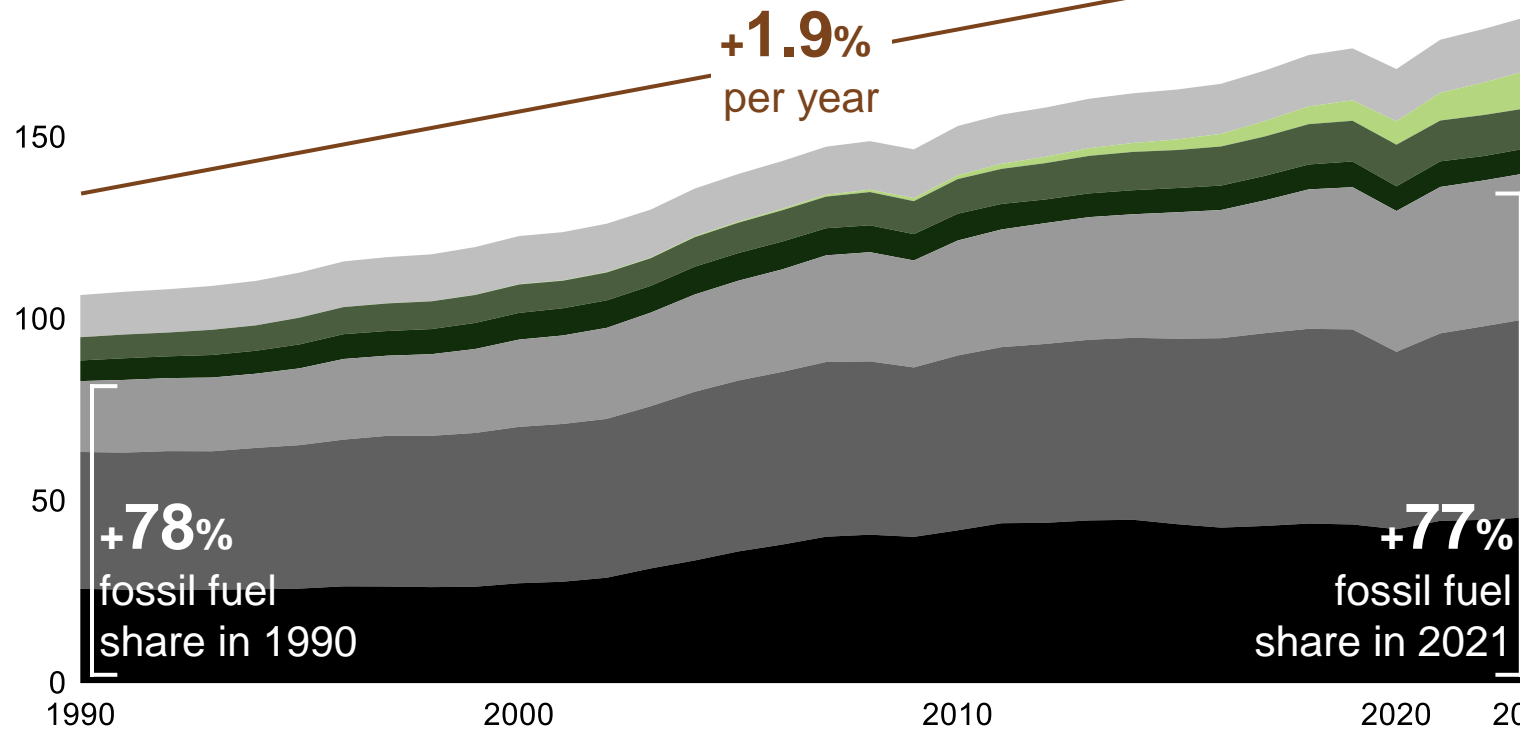

	percent of total 1990	percent of total 2023	Share of 1990-2023 demand growth
Coal	11%	8%	4%
Oil	0%	6%	13%
Gas	6%	6%	6%
Nuclear	5%	4%	1%
Hydro	18%	22%	27%
Wind & Solar	35%	30%	22%
Other*	24%	25%	26%

Note: * Other includes traditional biomass, biofuels, and other renewables
Source: Our World in Data *Energy Mix*

2

The Amount of Energy Supplied by Every Source, Excluding Traditional Biomass, Grew Over the Last Three Decades

Global primary energy consumption by source

PETAWATT-HOURS

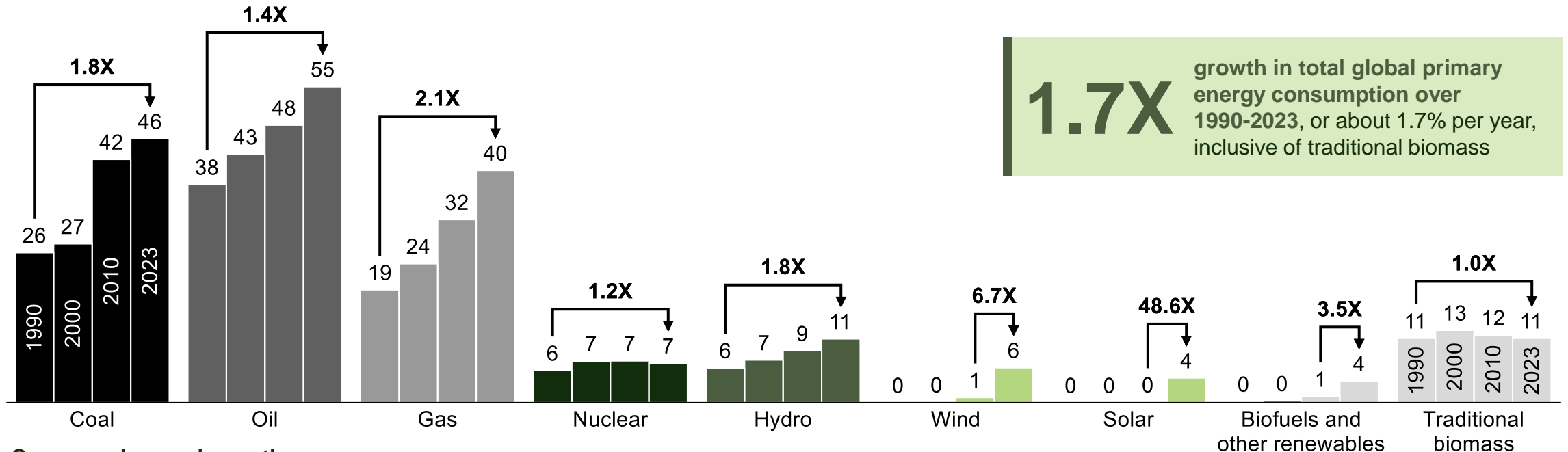

1.7X growth in total global primary energy consumption over 1990-2023, or about 1.7% per year, inclusive of traditional biomass

Compound annual growth

1990 - 2021

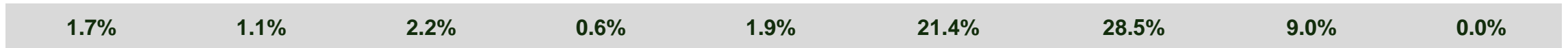

Source: Our World in Data

2

The Asia-Pacific Region Drove 75% of Energy Demand Growth Over 1990-2019, With China Alone Accounting for Nearly Half

Global primary energy consumption by country/region

Measured in petawatt-hours; excludes traditional biomass

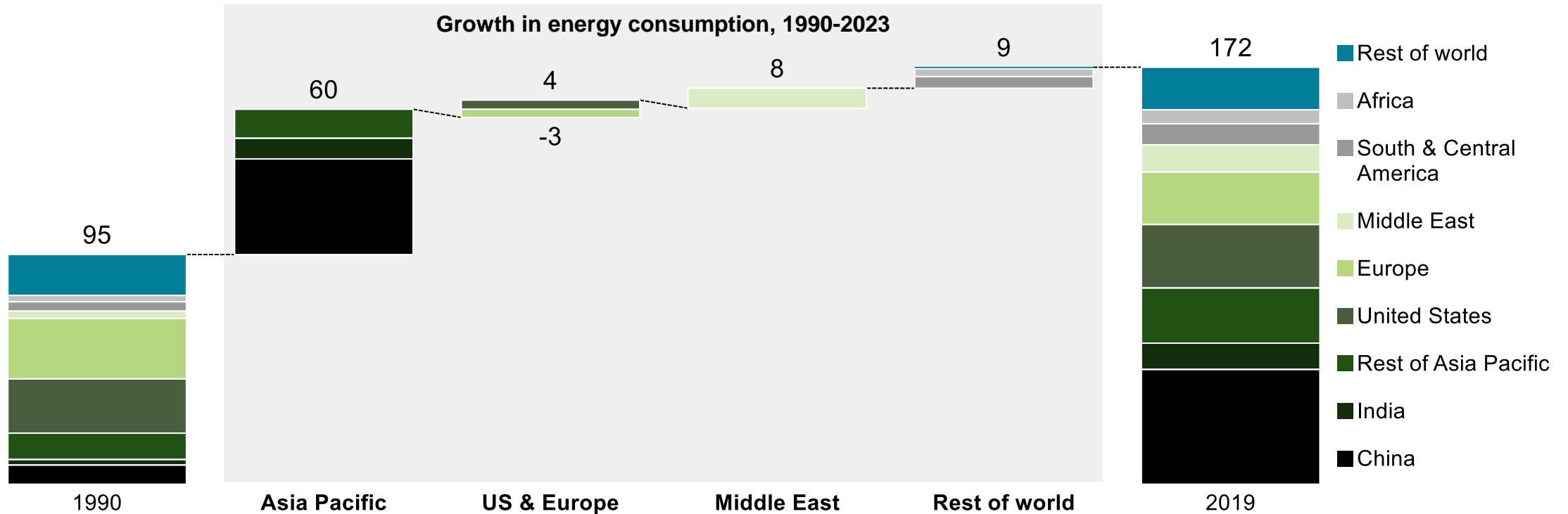

Note: Chart excludes traditional biomass (~10,000 TWh in 2019)
 Source: Our World in Data

2

Despite this Growth, a Material Share of the World Still Lacks Access to Electricity and Clean Cooking Fuels

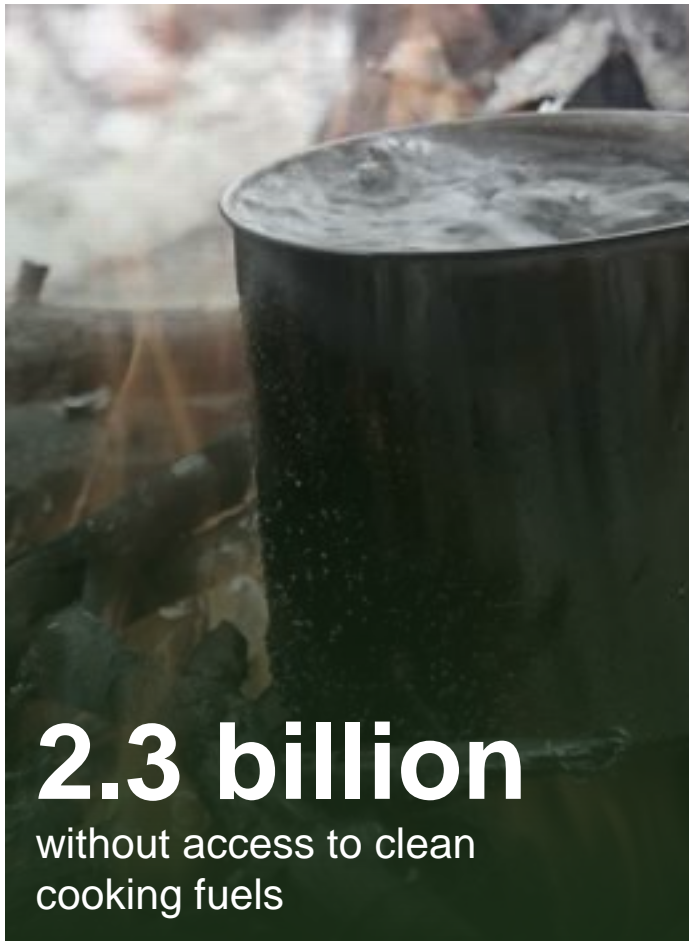

Share without electricity access in...



Source: World Bank; IEA

2

The Mix of Energy Sources Varies Widely by Country, Based on Local Resource Availability, Government Policy, and Economic Needs

Primary energy consumption by source – 2023

Measured in terawatt hours; excludes traditional biomass

Other Hydro Wind/solar Nuclear Gas Oil Coal

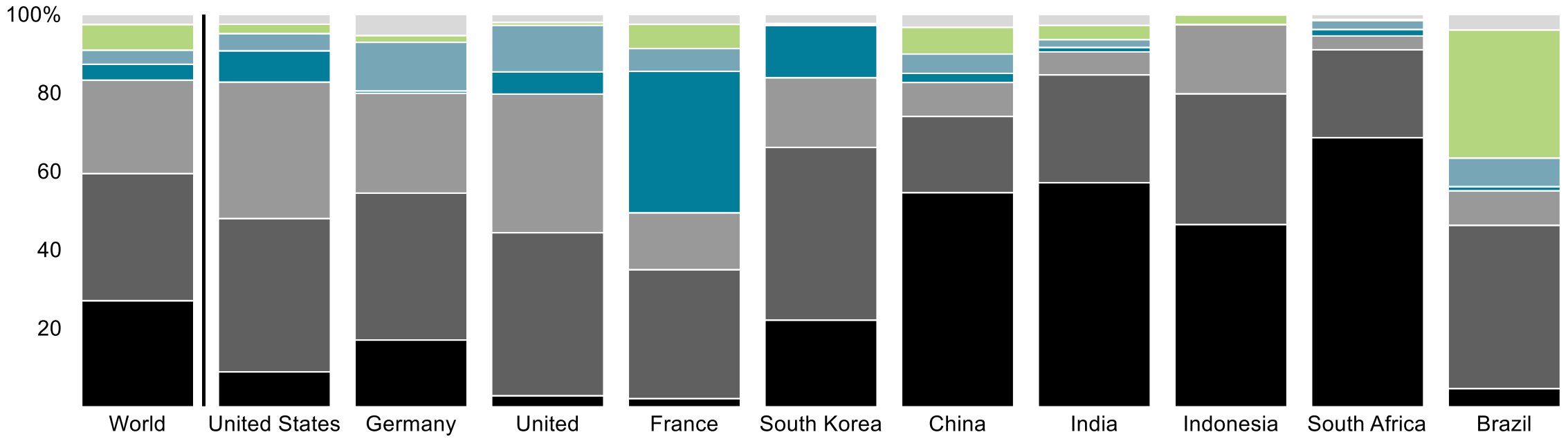

% fossil fuel



Note: Excludes traditional biomass. "Other" includes other renewables and biofuels

Source: Our World in Data [Energy Consumption by Source](#)

And Energy Prices for End Consumers Also Show Cross-Country Variability

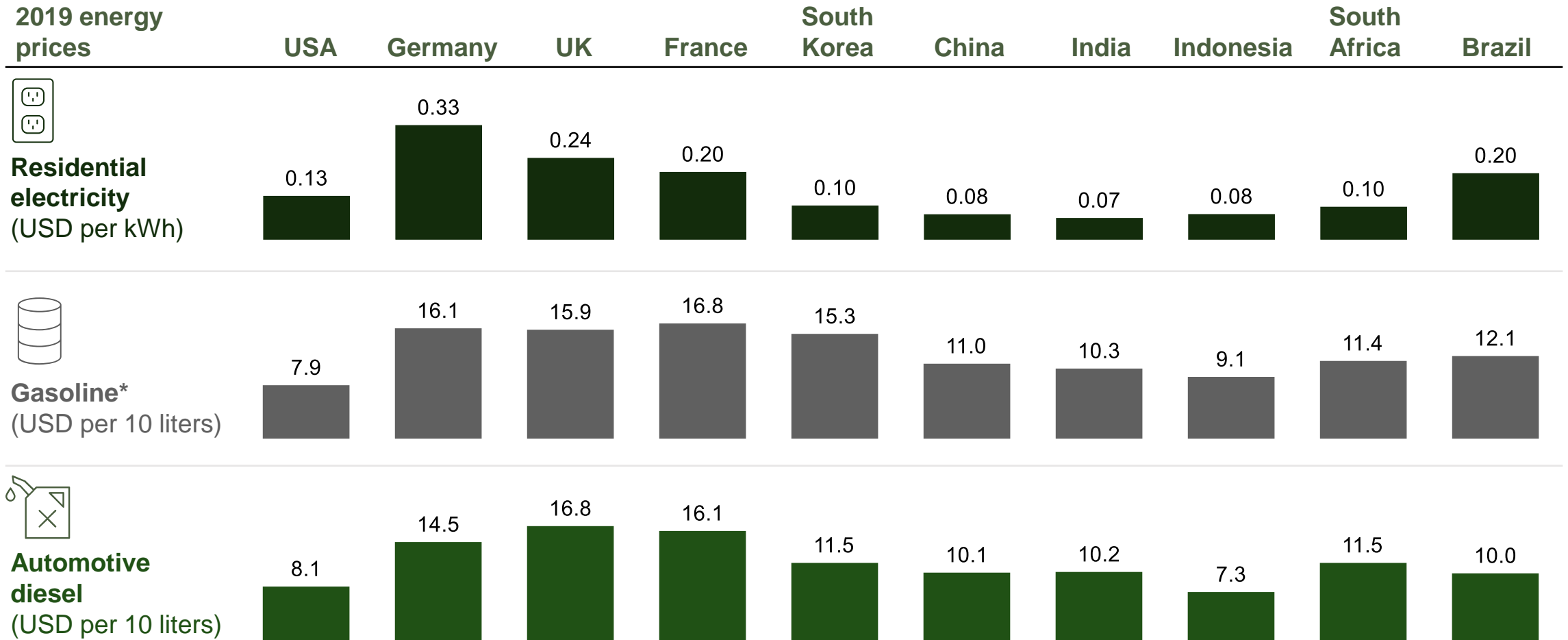

Note: * Premium unleaded petrol
 Source: Euromonitor

2 Population, GDP, and Efficiency Are Important Drivers of Energy Demand

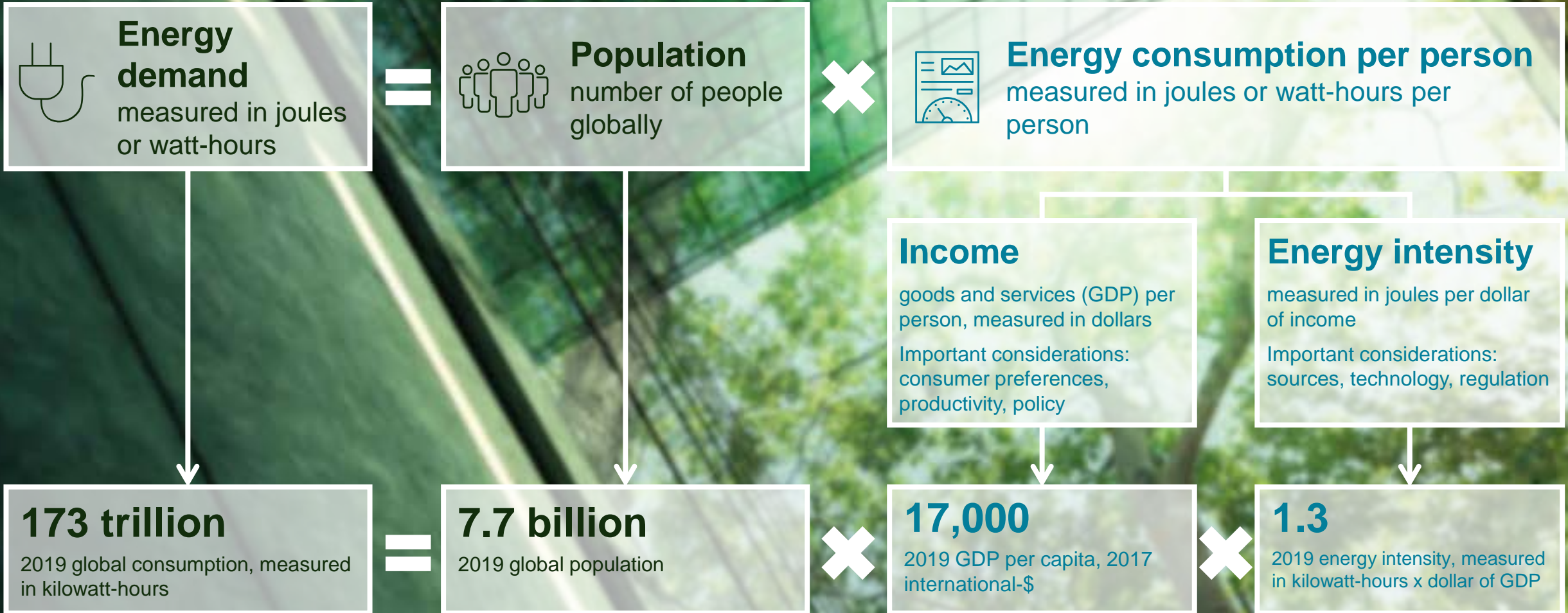

For Developing Economies, Economic Output and Energy Consumption Grow Together

Primary energy consumption per capita

MEGAWATT-HOURS

- China
- EU27 and UK
- United States
- Southeast Asia
- Japan
- Middle East and North Africa
- South Korea
- Sub-Saharan Africa
- India

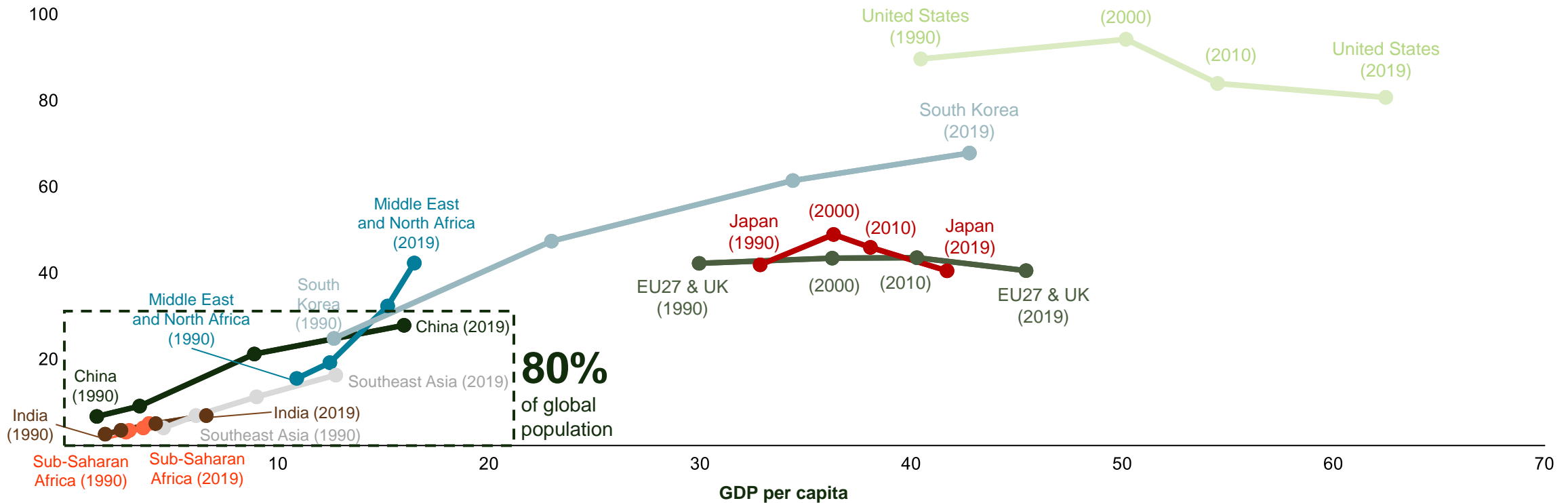

Thousands of constant 2017 USD, adjusted for purchasing power parity

Sources: Our World in Data; World Bank; BP Statistical Review of World Energy, 2022; EIA

Developing Countries, Particularly in Asia and Africa, Will Drive Population Growth Over the Next Decades

Global population

MILLIONS

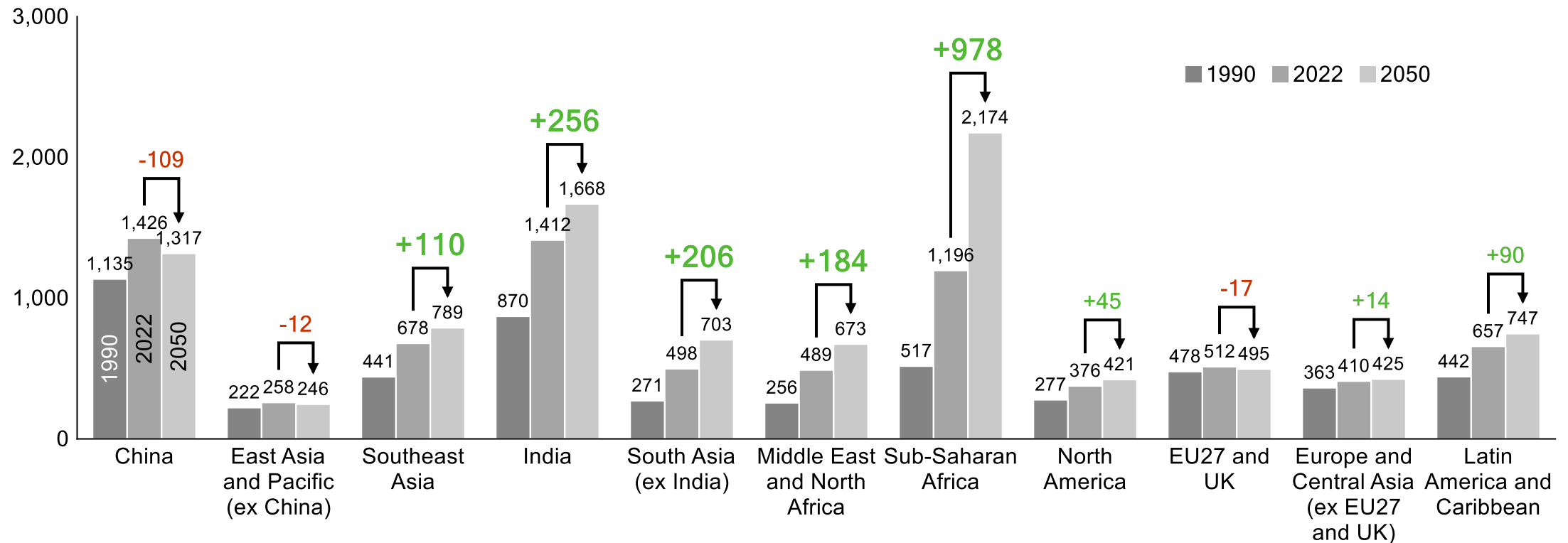

Source: UN, World Population Prospects 2022 (medium fertility variant); BP Statistical Review of World Energy, 2022; World Bank; EIA

2

Population Growth Will Be Overwhelmingly Concentrated in Regions of Lower Energy Consumption Today

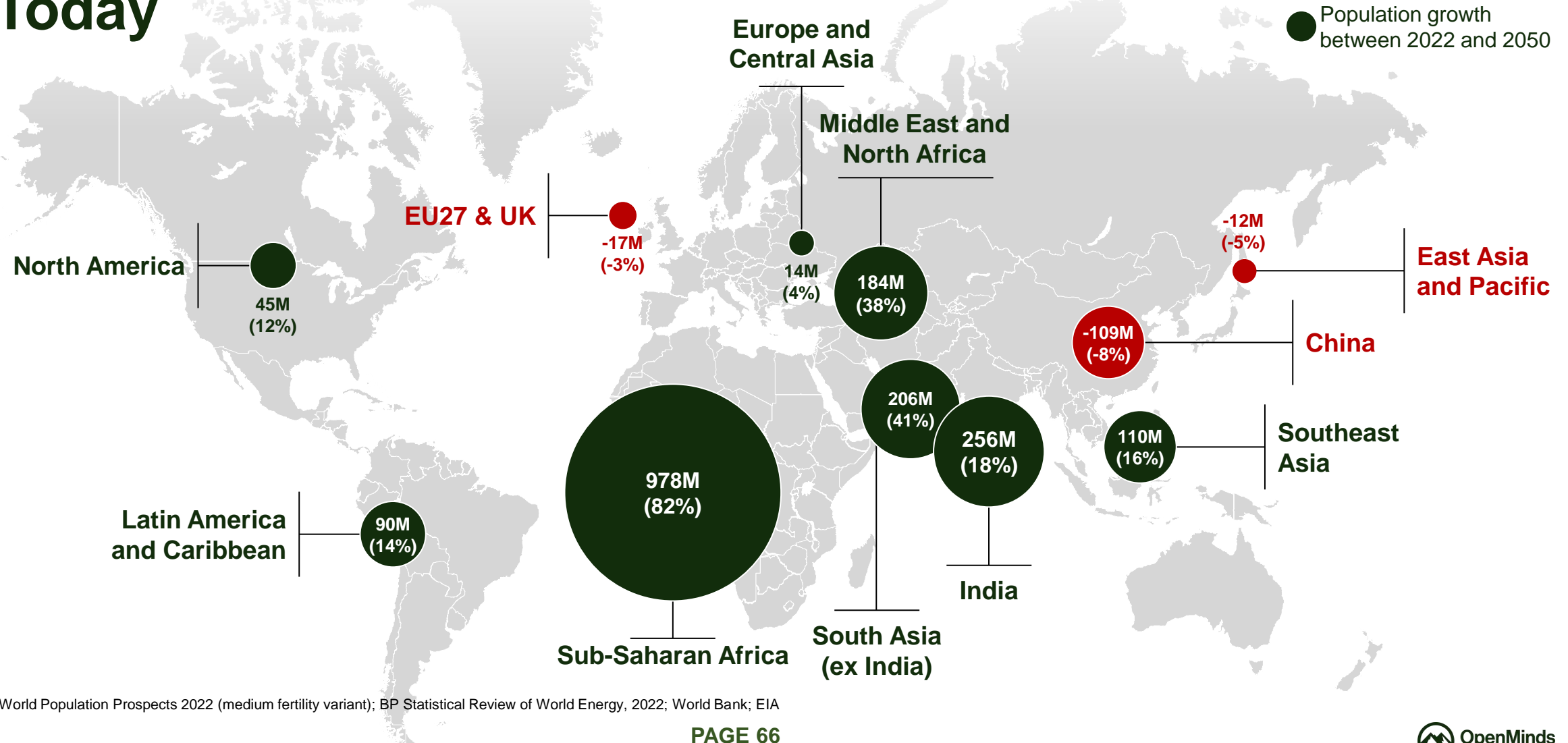

Source: UN, World Population Prospects 2022 (medium fertility variant); BP Statistical Review of World Energy, 2022; World Bank; EIA

2 Population Growth Will Be Overwhelmingly Concentrated in Regions of Lower Energy Consumption Today

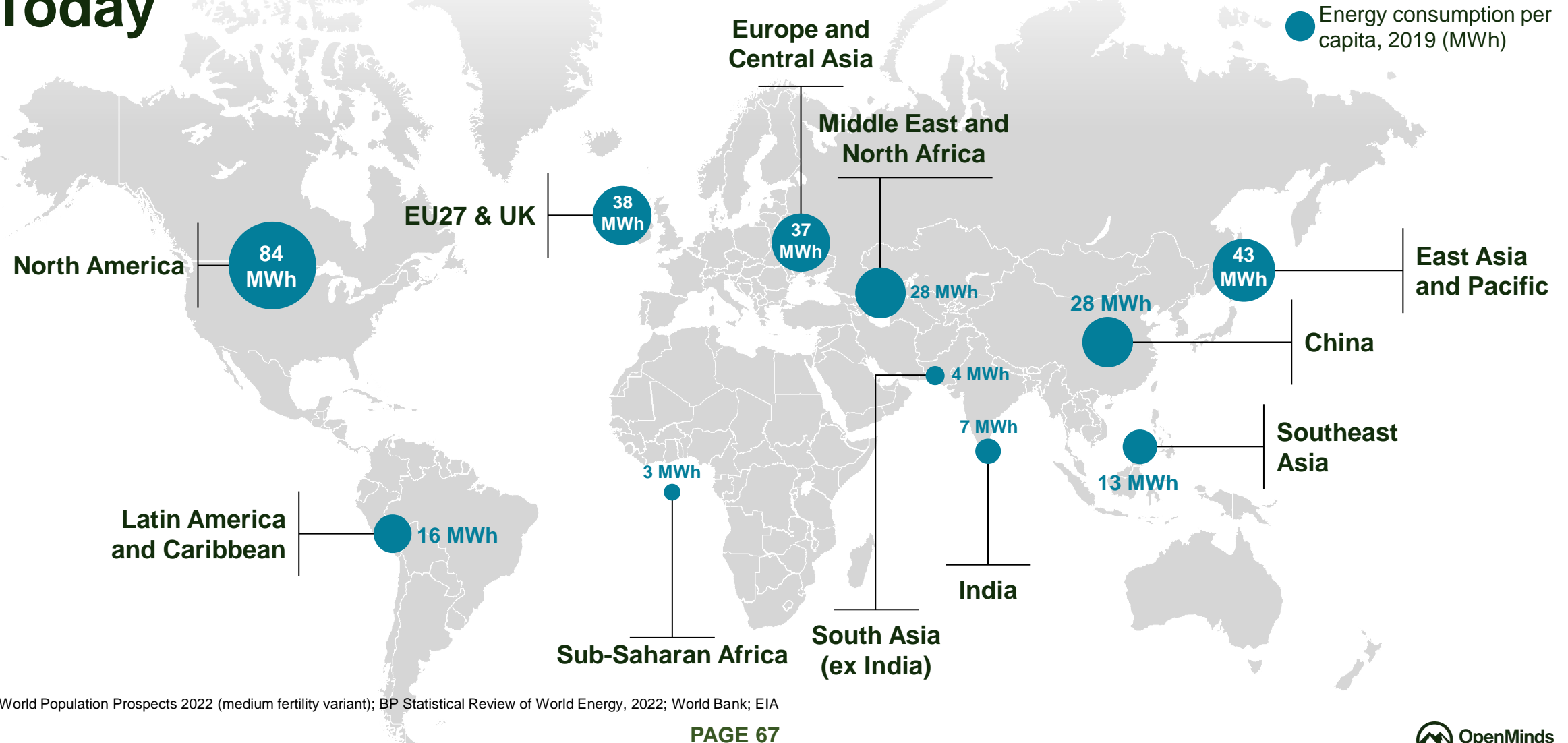

Source: UN, World Population Prospects 2022 (medium fertility variant); BP Statistical Review of World Energy, 2022; World Bank; EIA

2

Moreover, Urban Areas Will Grow by 2.2 Billion, Including Significant Growth in Africa and Asia, Through 2050

The world will increasingly urbanize over the next 30 years

Global population

MILLIONS

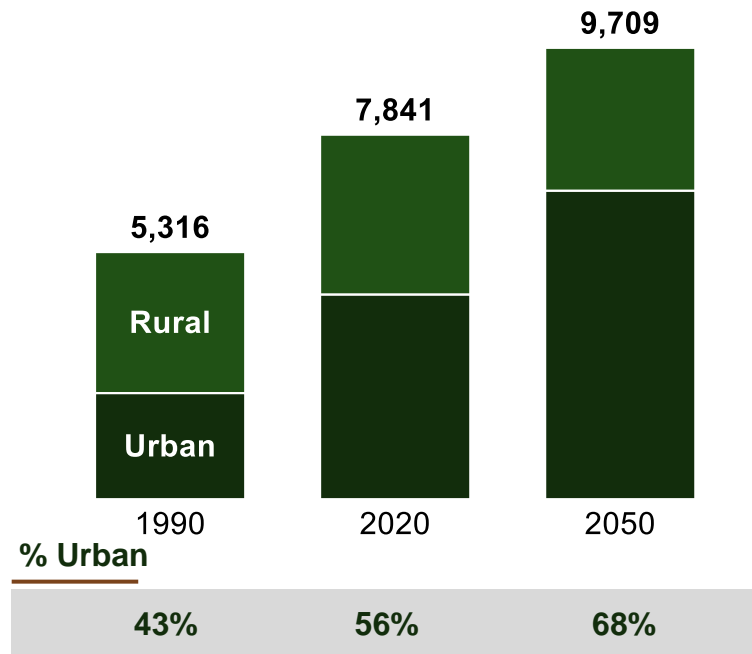

Source: UN World Urbanization Prospects (2018)

Urban population growth will be most pronounced in Africa and Asia

Urban population by region

MILLIONS

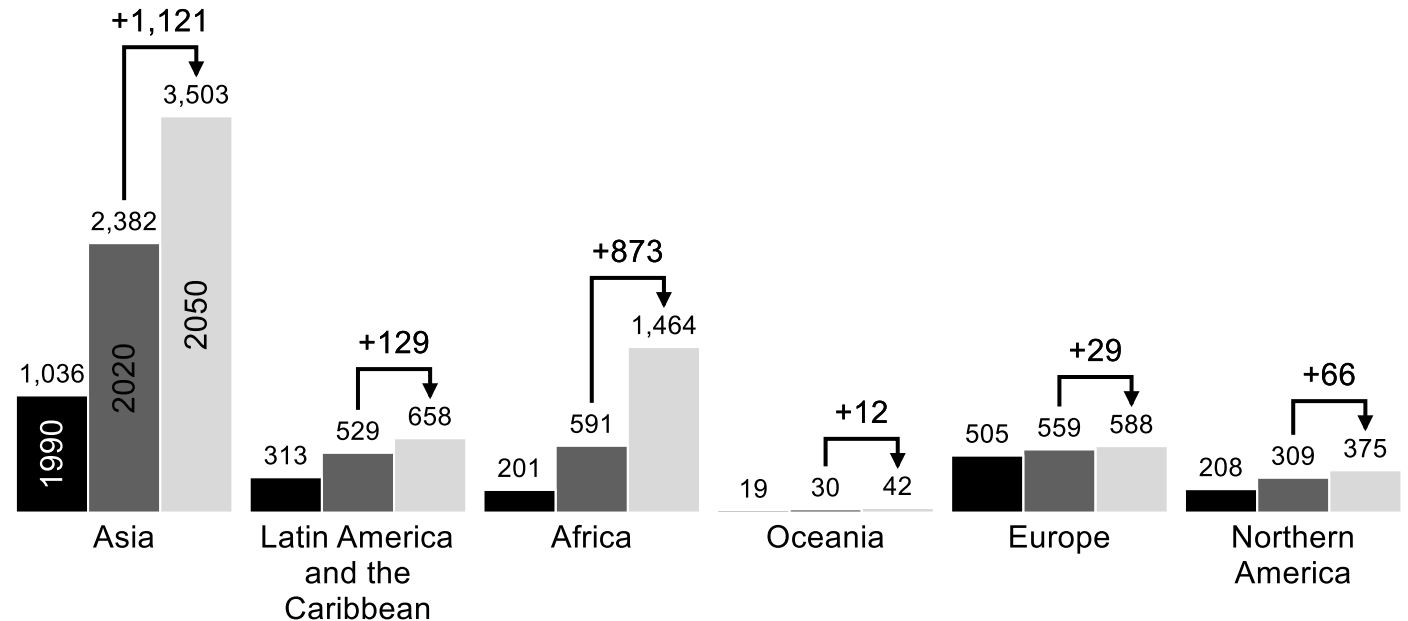

Global GDP Is Expected to More Than Double by 2050, Driven Mostly by Non-OECD Regions

GDP purchasing power parity, historical and forecast

PPP, TRILLIONS OF 2015 USD

ENERGY DEMAND DRIVER Income

goods and services (GDP) purchasing power parity, measured in dollars

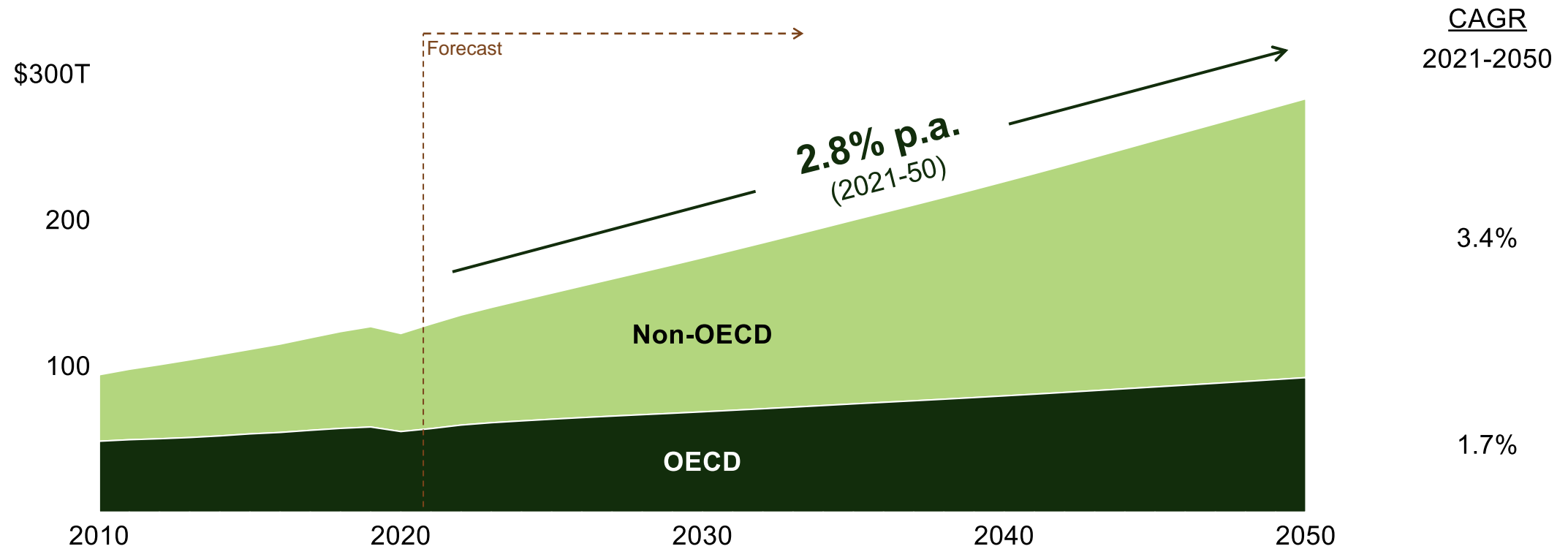

Source: U.S. Energy Information Administration, International Energy Outlook 2021 (IEO2021), reference case

GDP Growth is a Good Thing—More Than One Billion Have Been Lifted Out of Poverty in the Last 20 Years

Global population by income tier 2001 - 2019

MILLIONS OF PEOPLE

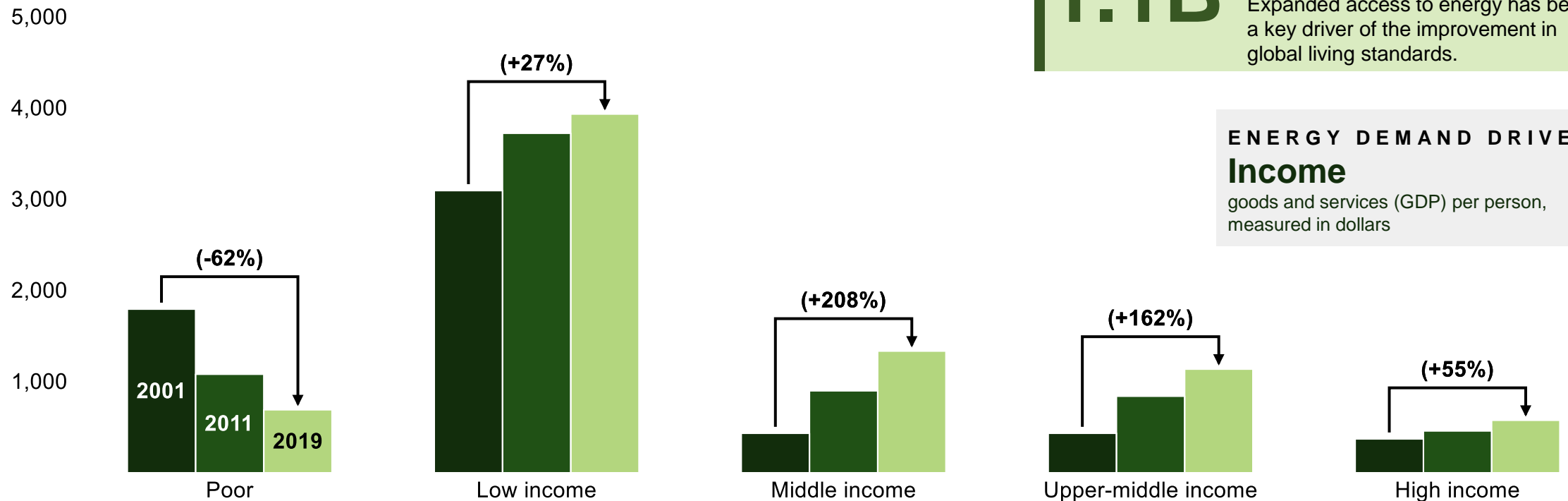

1.1B

decline in number of people considered poor since 2001 (from 29% to 9% of the global population). Expanded access to energy has been a key driver of the improvement in global living standards.

ENERGY DEMAND DRIVER Income

goods and services (GDP) per person, measured in dollars

Note: 1. Note: Income buckets defined as follows, Poor: <\$2/day, Low income: \$2.01-\$10/day, Middle income: \$10.01-\$20/day, Upper-middle income: \$20.01-\$50/day, High income: >\$50/day. Figures expressed in 2011 purchasing power parities in 2011 prices

Source: Pew Research Center; World Bank

We Have Become More Efficient Over Time: Energy Used Per Dollar of GDP Has Declined Around the World

Energy intensity per dollar

Consumption-based energy consumption, measured in kWh/\$, or kilowatt-hours divided by GDP, measured in 2017 international-\$

ENERGY DEMAND DRIVER Energy intensity

measured in joules per dollar of income

1990-2019
change

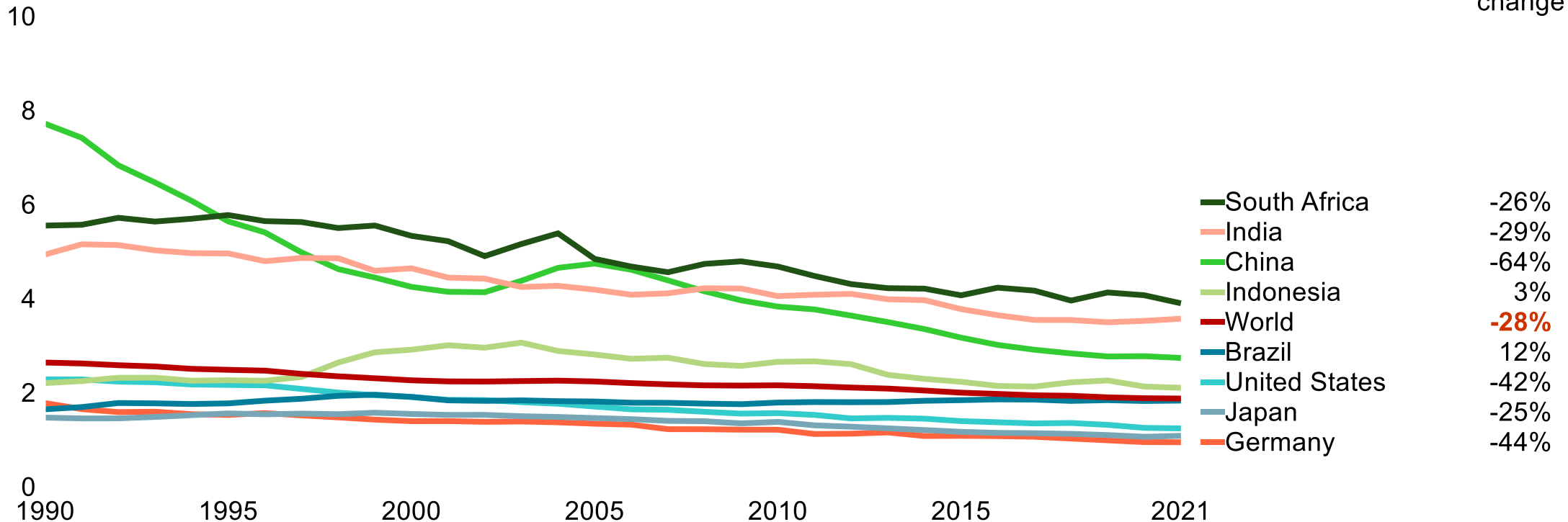

Note: GDP measured in 2017 international-\$, which adjusts for inflation and cross-country price differences

Source: EXIOBASE database, aggregated by Our World in Data

All Things Considered, Energy Demand Will Almost Certainly Continue to Grow for the Foreseeable Future

Global primary energy demand

PETA WATT - HOURS

250 PWh

200

150

100
1990

+1.6% per year
(1990-2019)

2000

2010

2020

2030

2040

2050

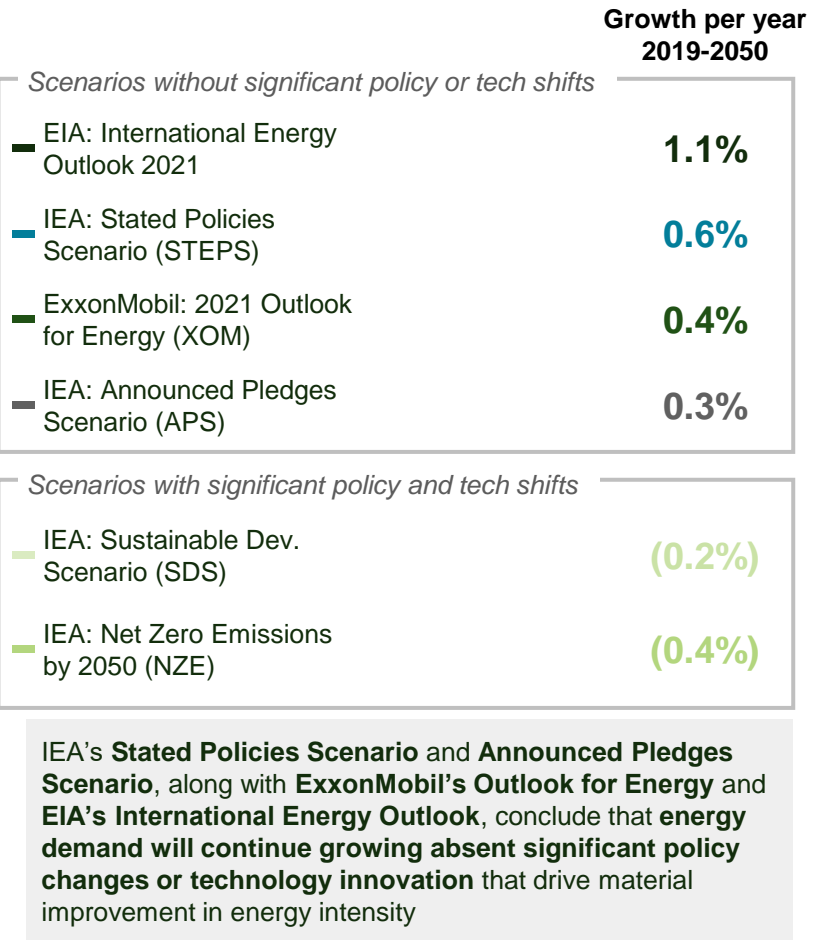

Source: BP Statistical Review of World Energy, 2021; ExxonMobil 2021 Outlook for Energy; International Energy Agency (2021), World Energy Outlook 2021, IEA, license: Creative Commons Attribution CC BY-NC-SA 3.0 IGO; EIA International Energy Outlook 2021

Energy: Uses, Sources, and Outlook



Modern civilization and quality of life depend on affordable & reliable energy supply



Fossil fuels have historically been that supply, enabling tremendous economic and standard of living improvements over the last century



Today, fossil fuels account for about 80% of total global energy supply



That share has not changed meaningfully over the last 30 years, during which time total supply grew by 60%



Despite consistent global growth in overall and per capita energy use, much of the world lacks access to sufficient energy



Future population growth will be concentrated in these low-energy regions



Delivering affordable, reliable energy will be key to enabling the development of these countries



Energy security is becoming more important with increased geopolitical tension



Total energy demand will continue rising; affordability, reliability, and security of supply will remain essential



Agenda

An aerial photograph of a wind turbine in a lush green field. The turbine's blades are white and extend across the frame. The field is divided into sections by thin lines, possibly irrigation or field boundaries. The overall scene is bright and clear.

01

OpenMinds
and the Dual
Challenge:
Executive
Summary

02

Energy: Uses,
Sources, and
Outlook

03

**Climate
Change:
Fundamentals
and Possible
Trajectories**

04

Reality Check:
Where We Are
Today

05

The Dual
Challenge:
Headwinds
and Tailwinds

Climate Change: Fundamentals and Possible Trajectories

- The Earth's climate, including average surface temperature, changes over time for a variety of reasons; fluctuations in the quantity, or concentration, of greenhouse gases (GHGs) in the atmosphere is one of those reasons
- Since 1850, human activity, including land use and fossil fuel combustion, has resulted in the release of more than two trillion cumulative tons of greenhouse gases, mostly carbon dioxide (CO₂), into the atmosphere
- The planet's natural CO₂ sinks have been unable to keep up with the volume of human emissions; consequently, the atmospheric concentration of CO₂ has increased by about 50% versus pre-industrial times
- Rising CO₂ (and other GHG) concentration, caused by human activity, has been a key driver of an observed increase in average global surface temperature
- Warming has already produced adverse human and ecosystem impacts, and further warming will amplify risks such as accelerated sea level rise and increased frequency and severity of certain types of extreme weather
- The largest anthropogenic source of emissions is the production and combustion of fossil fuels for transportation, electricity generation, and heating; such fuels are the source of 80% of the world's primary energy
- As their economies grew and became more energy-intensive, Asia has quickly emerged as the leading GHG emitter globally, but the US and Europe together emitted significantly more than any other region during the last century

To limit warming and mitigate the worst risks of climate change, anthropogenic greenhouse gas emissions will need to decline significantly, and ideally reach zero, within a few decades—this can only be accomplished as an “all of us” global effort

3

“Climate” Refers to Long-Term Average Weather Patterns

Weather

Short-term (day-to-day or hour-to-hour) atmospheric conditions

Tuesday

August 2, 2022

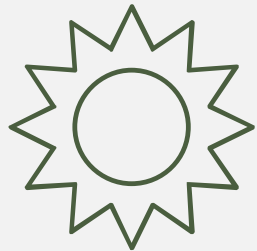

93°F

Wednesday

August 3, 2022



91°F

Thursday

August 4, 2022



89°F

Climate

Long-term (multi-year or multi-decadal) average weather patterns

30-year average: Daily temperatures in Austin, TX

(1991 - 2020)

30-year average: Number of days with ≥0.5 in. precipitation in Austin, TX

(1991 - 2020)

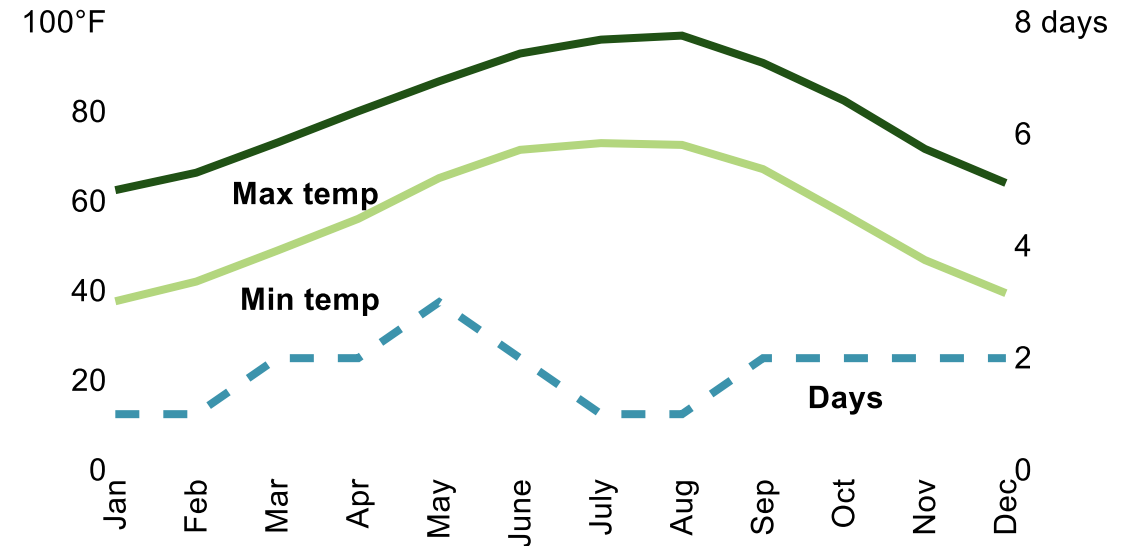

Note: Temperature and precipitation data reflective of Austin, Texas over 1991-2020; data from Austin Bergstrom weather station
Source: NOAA, USGS, NASA

The Earth's Climate, Including Average Surface Temperature, Changes Over Time





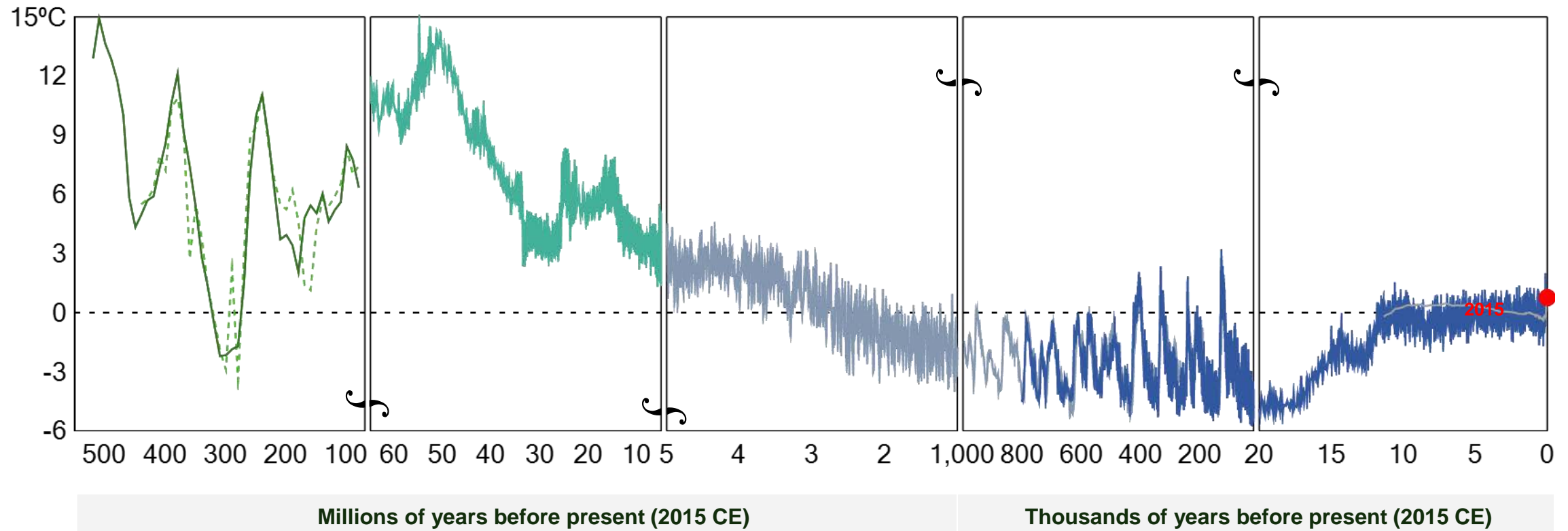

Global average surface air temperature over the last 540 million years
 (DIFFERENCE VS. 1961-1990 AVERAGE, °C)

- Royer et al (2004) – CO₂ from GEOCARB
- - - Royer et al (2004) – CO₂ from proxies
- Zachos et al (2008) & Hansen et al (2013)
- Lisiecki and Raymo (2005)
- EPICA Dome C, Antarctica, Jouzel et al 2007
- Marcott et al (2013)



Source: Royer et al (2004); Zachos et al (2008); Hansen et al (2013); Lisiecki and Raymo (2005); EPICA Dome C, Antarctica; NGRIP, Greenland; Marcott et al (2013); data compiled by Glen Fergus

Climate Fluctuates for a Variety of Reasons, Including Changes in the Atmospheric Concentration of Greenhouse Gases

Factor	Description
 Variation in solar output	The energy output of the sun is not constant, and changes in its irradiance affect climate
 Changes in the Earth's orbit around the sun	The Earth's eccentricity, axial tilt, and precession change over time, and these changes influence climatic patterns, including periods of glaciation
 Changes in the Earth's reflectivity	The Earth's albedo, or reflectivity, affects how much sunlight the planet absorbs. This effect can act as a feedback to other processes
 Quantity of greenhouse gases in the atmosphere	Certain gases like water vapor and CO ₂ impede the flow of infrared heat (solar radiation) from the Earth's surface into space, thereby warming the planet. This is the "greenhouse effect"
 Changes in ocean currents	Ocean currents carry heat around the earth. Changes in circulation and heat content affect climate
 Volcanic eruptions	Gas and particles thrown into the atmosphere during volcanic eruptions may warm or cool the Earth's surface

Source: British Geological Survey; EPA

The Quantity of Greenhouse Gases (GHGs) in the Atmosphere Influences Climate Via the Greenhouse Effect

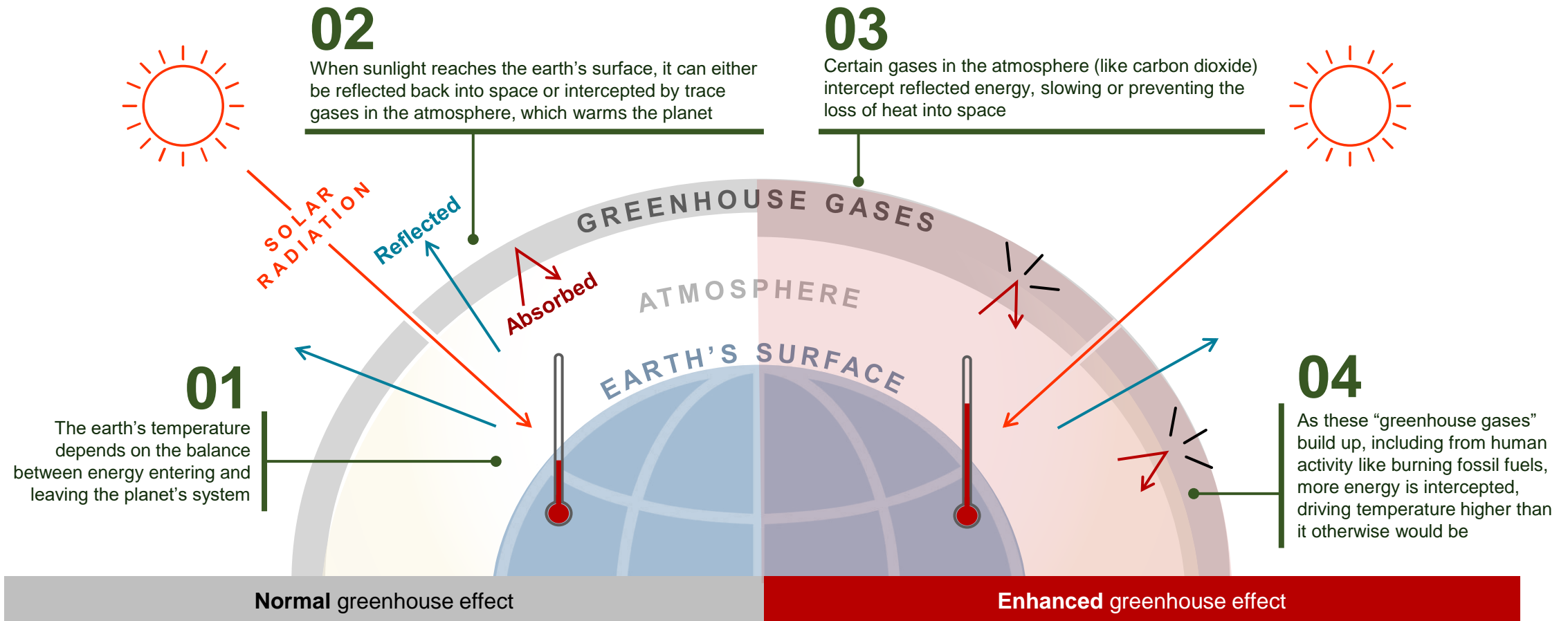

3

Certain Human Activities Result in the Release of Several Types of Greenhouse Gases, Mostly Carbon Dioxide (CO₂)

Typical sources

(non-exhaustive)

- Carbon dioxide (CO₂)**
- Methane (CH₄)**
- Nitrous oxide (N₂O)**
- Fluorinated gases**

Fossil fuel combustion, cement production, steel production

Natural gas production, livestock, landfills

Agricultural soil management (fertilizer application) and fuel combustion

Industrial processes such as electronics manufacturing and aluminum production

Global warming potential

(GWP, which measures how much a gas would warm the earth in a 100-year period compared to one ton of CO₂)

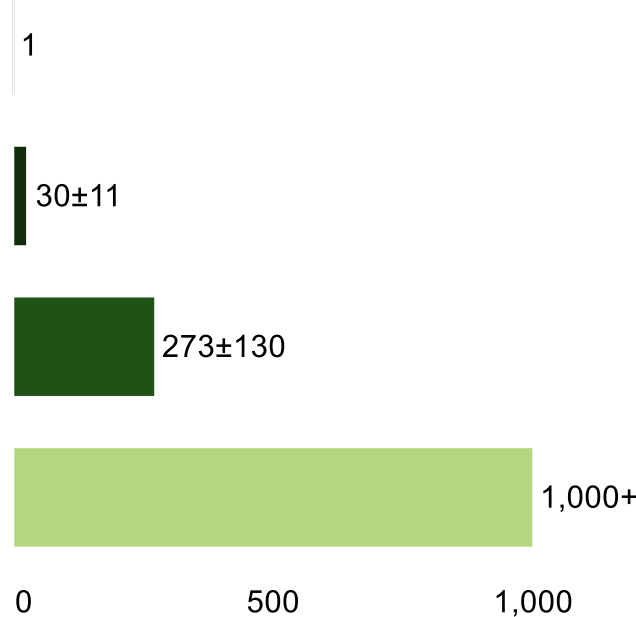

Human GHG emissions

(measured in billions of tons of CO₂-equivalent, i.e., adjusted for GWP factor)

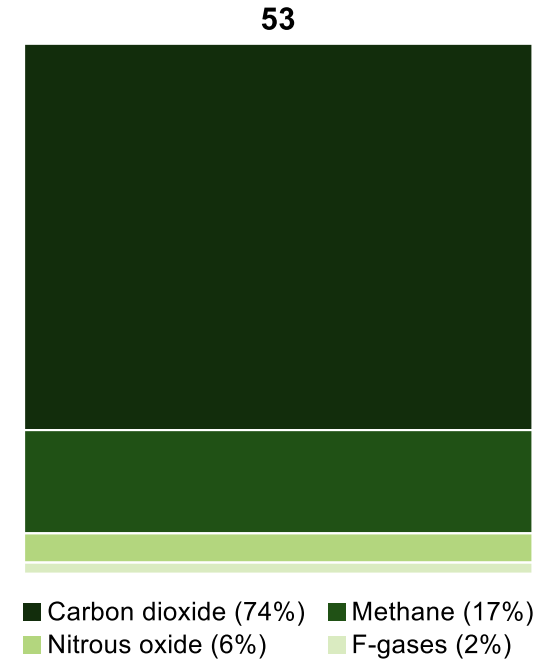

Note: Global Warming Potential uncertainties expressed as 5-95% confidence interval based on IPCC AR6. Source: [EPA](#); IPCC, Sixth Assessment Report (AR6), Working Group I, [Chapter 7](#), Table 7.15; IPCC, Fifth Assessment Report (AR5), Working Group I, Box 6.1, [Figure 1](#); Daniel A. Vallero, *Air Pollution Calculations* (2019), [8.3.2](#); [Climate Watch](#); Our World in Data. Additional detail can be found in the appendix

3

For Example, CO₂ is a Product of Fossil Fuel Combustion, as is a Significant Quantity of Energy in the Form of Heat

Natural gas example

Natural gas, or methane, is commonly used in homes for space heating, water heating, and/or cooking and in power plants for producing electricity. When combusted, it produces CO₂ and water, along with a significant quantity of energy in the form of heat

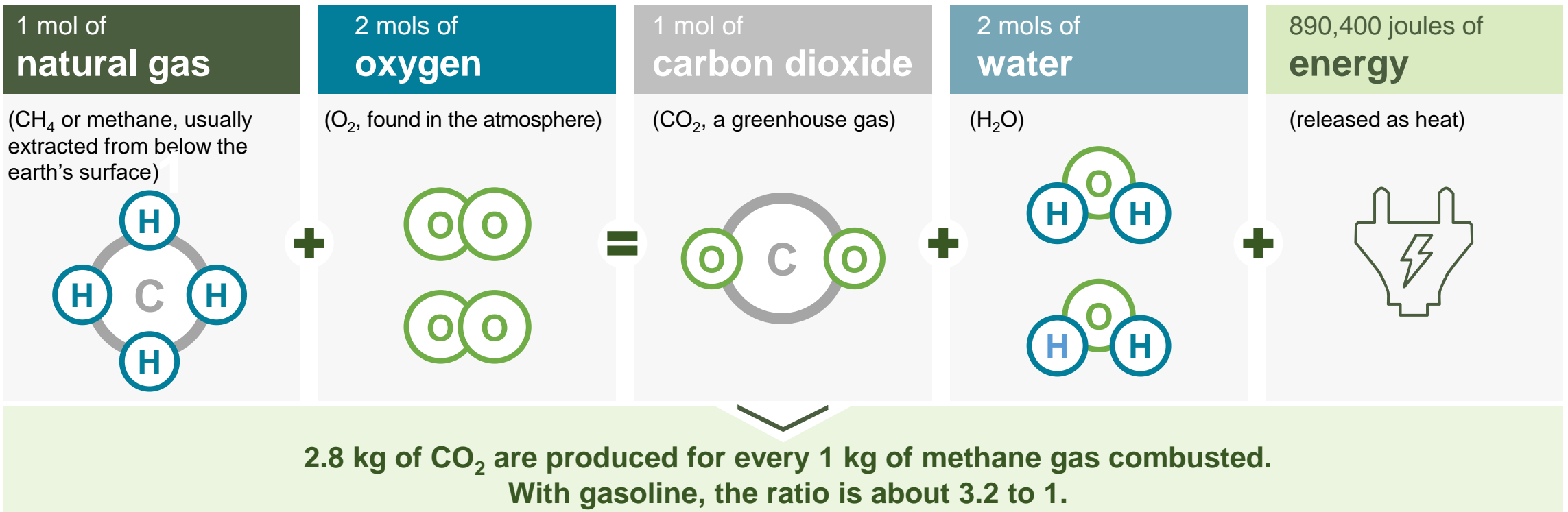

Note: 1 mol = 6×10^{23} molecules. 1 mol of water weighs about 18 grams

3

Altogether, the Combustion of Fossil Fuels Accounts for More Than Three-Quarters of Total Anthropogenic GHG Emissions

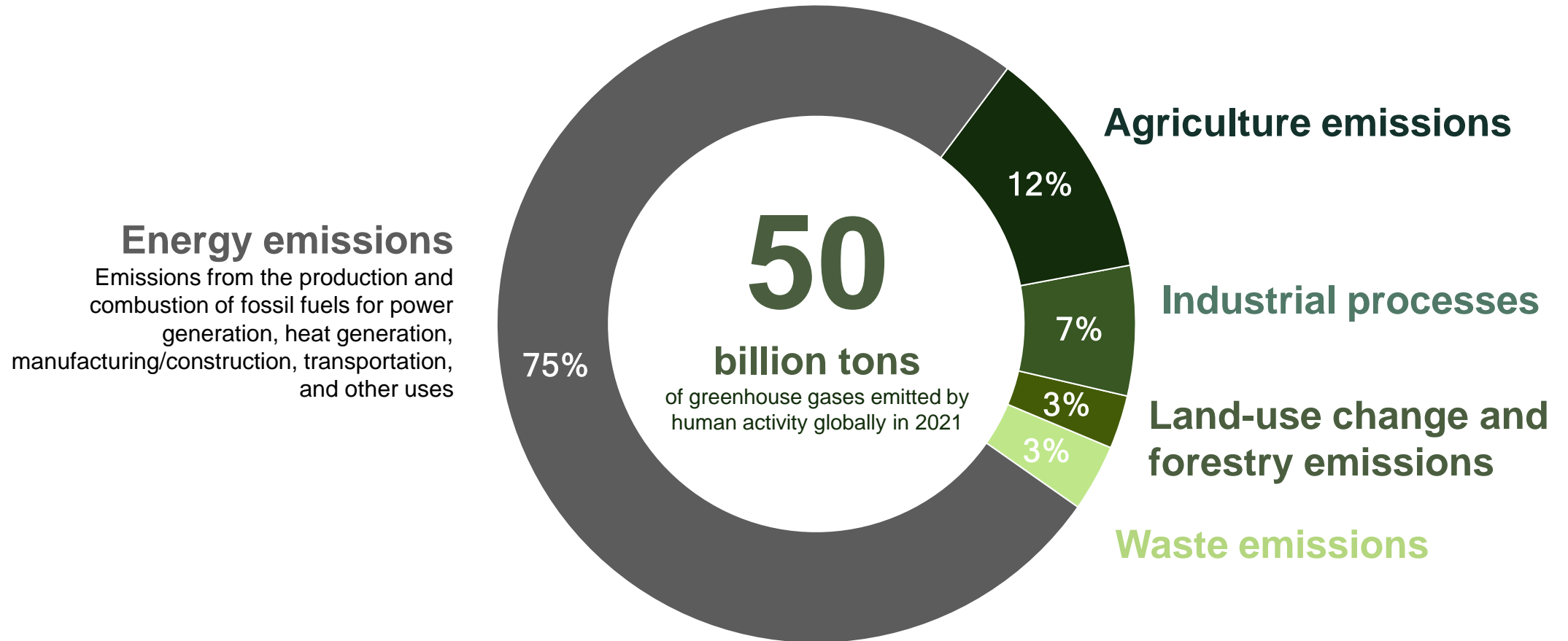

Note: Emissions measured in tons of CO₂-equivalent and include carbon dioxide, methane, nitrous oxide, and f-gases
Source: Our World in Data; Climate Watch

3

When Considering the Climate Impact of Anthropogenic GHG Emissions, it is Helpful to Think of the Atmosphere as a Bathtub

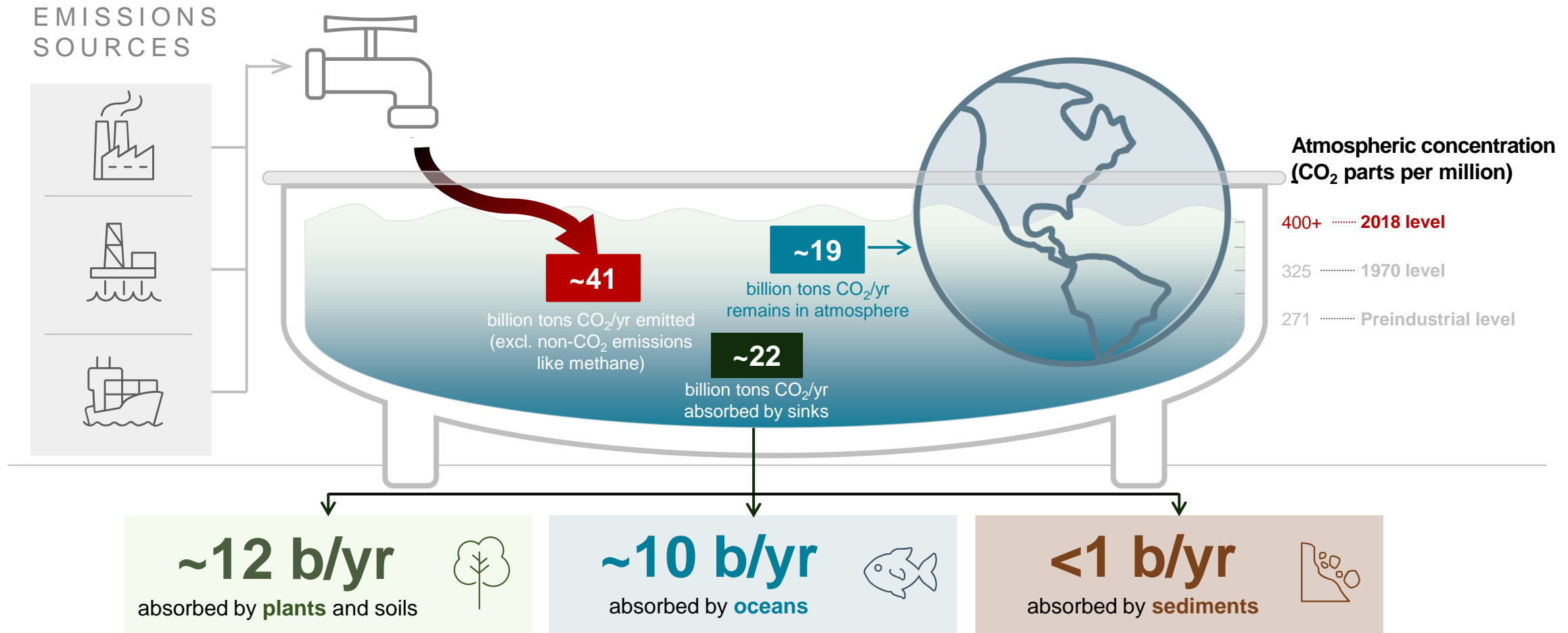

3

Anthropogenic CO₂ Emissions, the “Faucet”, Have Doubled Since 1975

Annual global CO₂ emissions from energy and land use change

(MEASURED IN BILLIONS OF TONS OF CO₂; EXCLUDES NON-CO₂ GHGS)

50B Tons

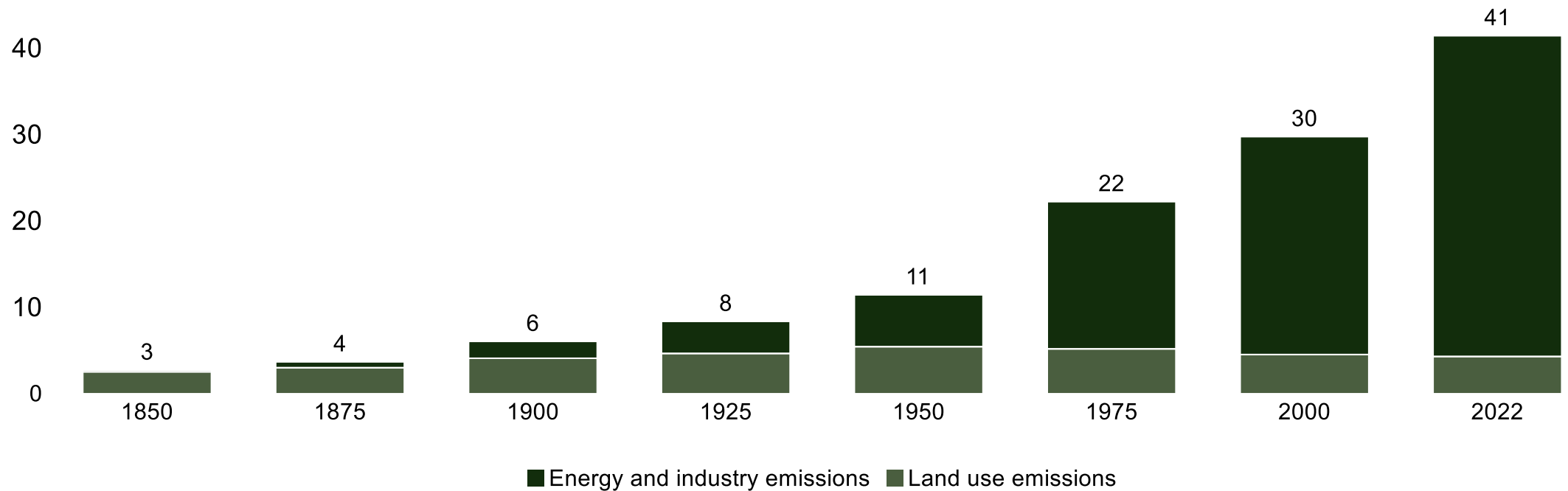

Source: Global Carbon Project; Our World in Data

3

Since 1850, Human Activity Has Caused the Release of More Than Two-Trillion Cumulative Tons of CO₂

Cumulative global CO₂ emissions from energy and land use change

Measured in billions of tons of CO₂, from 1850 through 2020; excluding non-CO₂ emissions (e.g., methane)

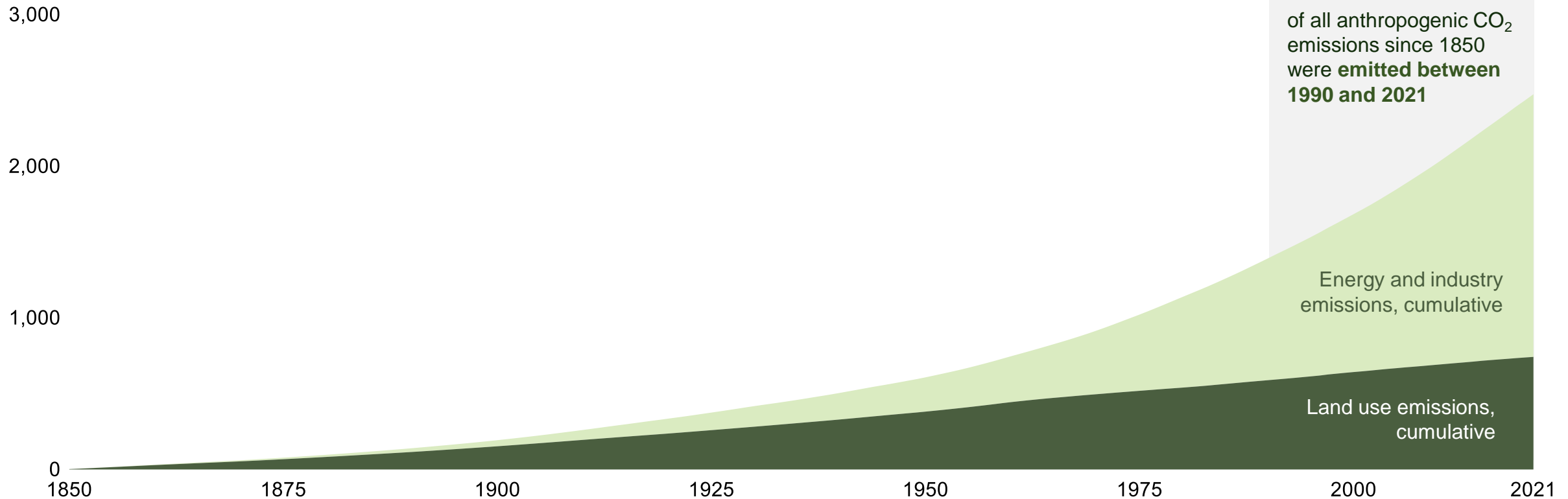

Source: Global Carbon Project; Our World in Data

3

The Earth's Natural Carbon System Affects the Quantity of Anthropogenically Emitted Carbon That Remains in Atmosphere

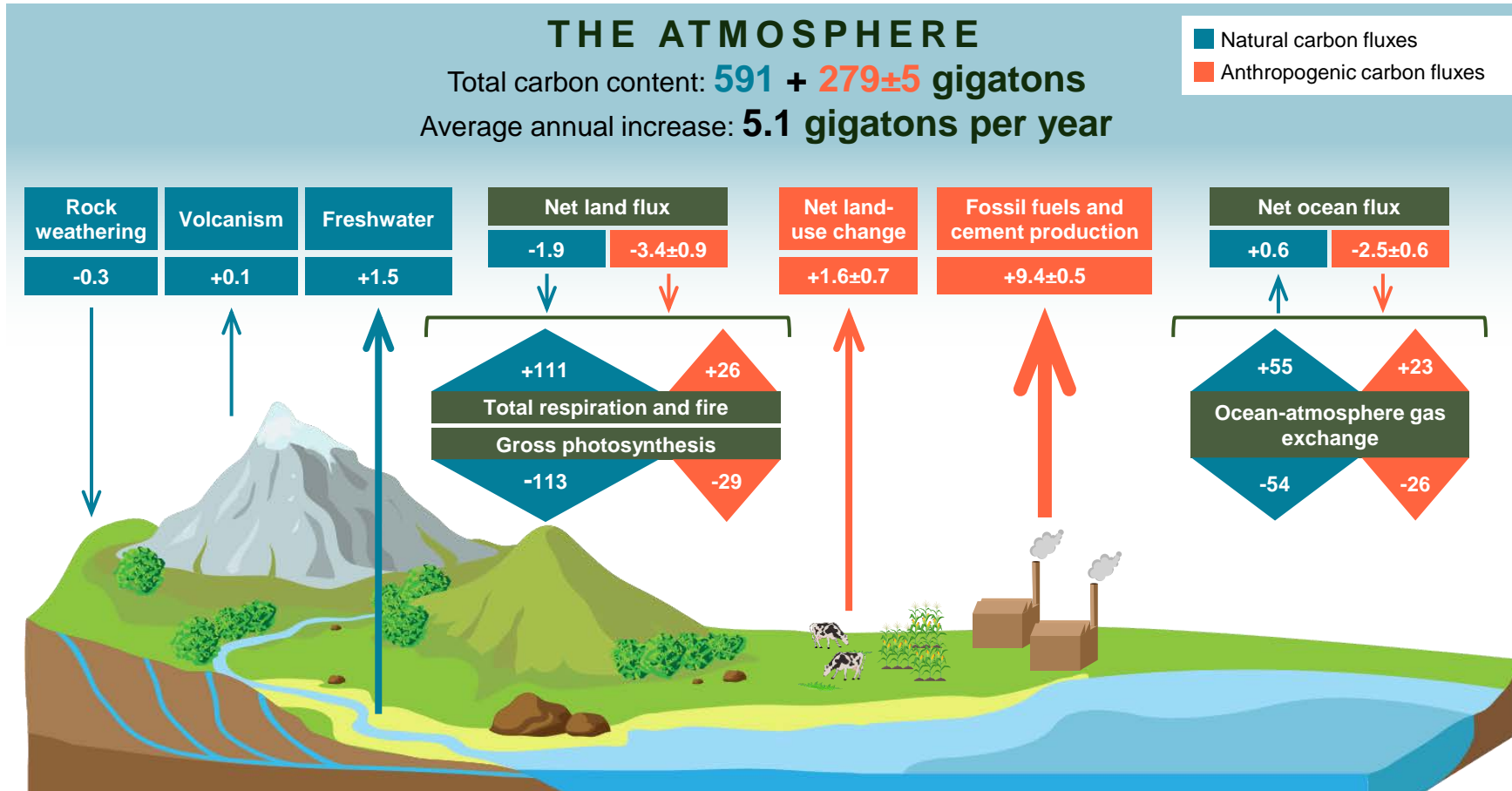

All figures are in gigatons of carbon (not CO₂) per year except total atmospheric content

Natural carbon fluxes (blue arrows) represent annual carbon fluxes associated with the natural carbon cycle, estimated for the time prior to the industrial era (pre-1750)

Anthropogenic carbon fluxes (yellow arrows) are averaged over the period 2010-2019

Total atmospheric content reflects the total stock of carbon in the atmosphere today (denoted as the sum of the pre-industrial stock and the anthropogenic change since 1750)

Of about 11 gigatons of anthropogenically emitted carbon per year, **roughly 55% is absorbed by the land and ocean**

Source: IPCC, Sixth Assessment Report (AR6), Working Group I, Chapter 5, Global Carbon and Other Biogeochemical Cycles and Feedbacks (2022)

3

The Earth's Natural Carbon Sinks, the "Drain", Have Been Unable to Keep Up With the Pace of Anthropogenic Emissions

Global annual CO₂ sources and sinks

(MEASURED IN BILLIONS OF TONS OF CO₂)

60B Tons

45% or 20B tons

of emitted CO₂ **remains in the atmosphere** instead of being absorbed by natural sinks

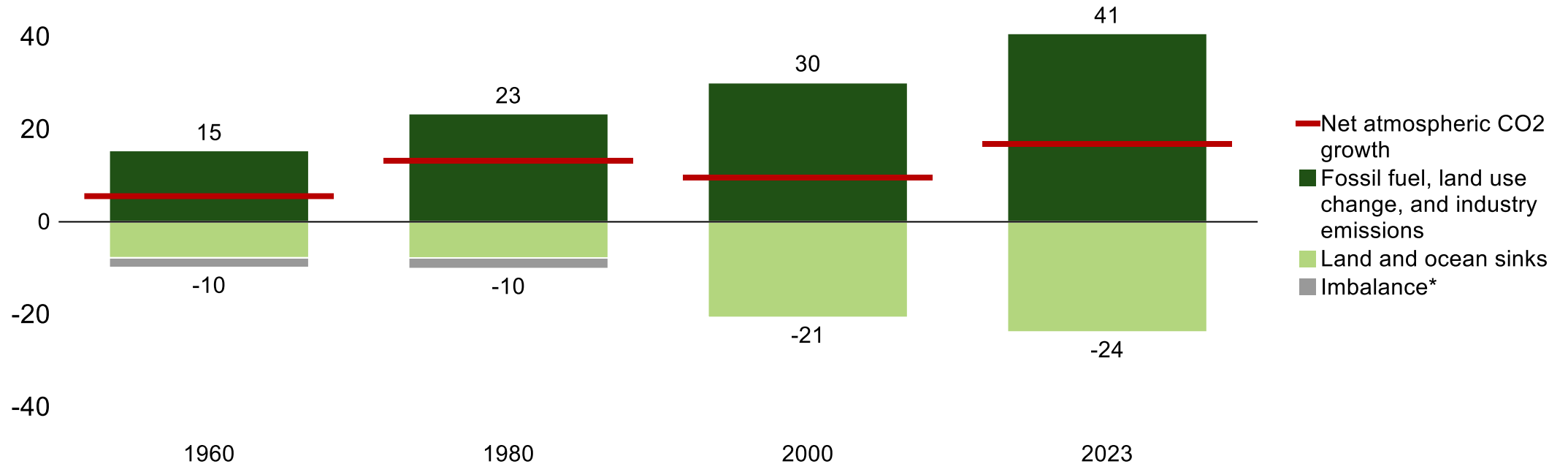

Note: * The "imbalance" is the sum of emissions minus sinks; it is a measure of our imperfect data and understanding of the contemporary carbon cycle.

Source: Global Carbon Project

3

As a Result, the Atmospheric Concentration of CO₂, the “Fill Level”, Has Risen Rapidly Over the Past Century

Atmospheric CO₂ concentration

(GLOBAL AVERAGE LONG-TERM ATMOSPHERIC CONCENTRATION OF CO₂, MEASURED IN PARTS PER MILLION [PPM]. LONG-TERM TRENDS IN CO₂ CONCENTRATIONS CAN BE MEASURED AT HIGH-RESOLUTION USING PRESERVED AIR SAMPLES FROM ICE CORES)

400 ppm

300

200

100

0

-800,000 BCE

-600,000 BCE

-400,000 BCE

-200,000 BCE

2018

Source: NOAA

3

Due to the Greenhouse Effect, Increased Atmospheric CO₂ Concentration Has Caused a Rise in Global Temperature

Average global temperature anomaly

°C

Atmospheric CO₂ concentration

PARTS PER MILLION (PPM)

1.5°C

500ppm

1.0

0.5

0.0

-0.5

-1.0

1850

1870

1890

1910

1930

1950

1970

1990

2010

2023



1.2°C

Approximate warming since pre-industrial times

Median global temperature anomaly

Atmospheric CO₂ Concentration

Note: The green line represents the median average temperature deviation, or anomaly, vs. the 1961-1990 baseline (average) value. Atmospheric CO₂ concentration reflects the annual average. Source: Hadley Center; NOAA; IPCC, Sixth Assessment Report (AR6), *Climate Change 2021: The Physical Science Basis, Summary for Policymakers*, A.1.2 (2022); Our World in Data

3

In Climate, “a Little is a Lot” With Respect to Temperature Changes

Last ice age

when ~25% of Earth’s land area was covered in glaciers



6°C

degrees **lower** than today

Age of the dinosaurs

when crocodiles could be found above the Arctic Circle

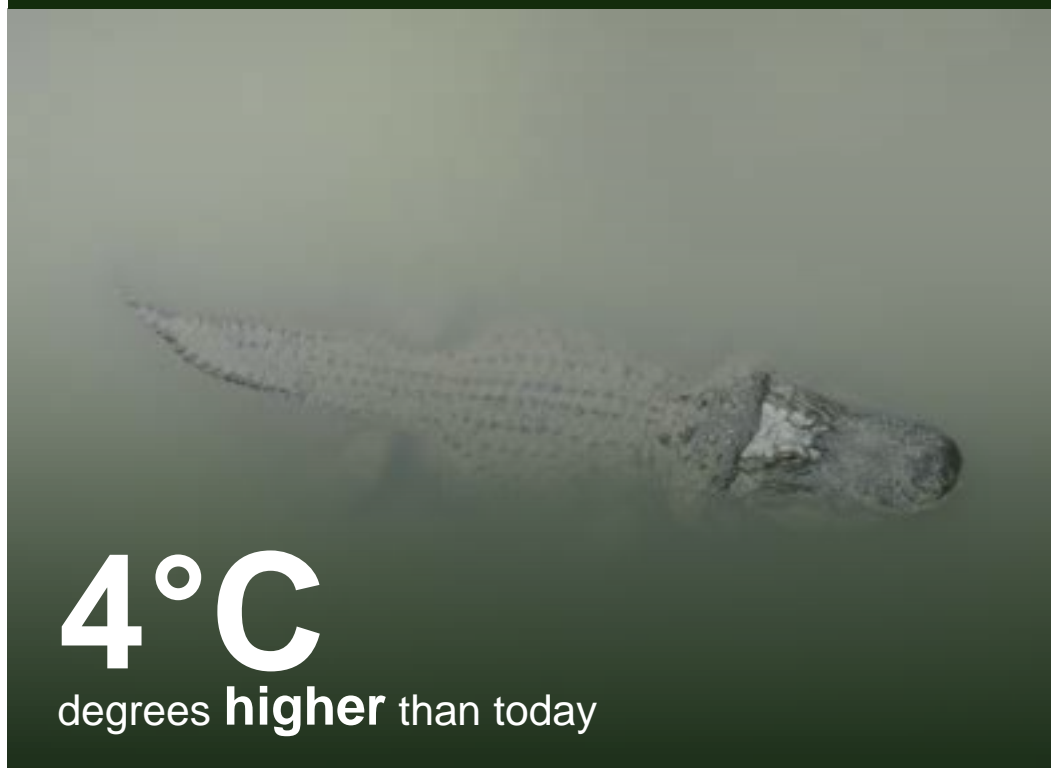

4°C

degrees **higher** than today

Warming Has Already Produced Adverse Impacts

Observed impact on ecosystems



Changes in ecosystem structure

Climate change has caused substantial damages, and increasingly irreversible losses, in terrestrial, freshwater and coastal and open ocean marine ecosystems (**high confidence**)."

Species range shifts

Hundreds of local losses of species have been driven by increases in the magnitude of heat extremes (**high confidence**), as well as mass mortality events on land and in the ocean (**very high confidence**)."

Observed impact on human systems



Water scarcity and food production

Climate change including increases in frequency and intensity of extremes have reduced food and water security, hindering efforts to meet Sustainable Development Goals (**high confidence**)"

Health and wellbeing

The occurrence of climate-related food-borne and water-borne diseases has increased (**very high confidence**). The incidence of vector-borne diseases has increased from range expansion and/or increased reproduction of disease vectors (**high confidence**)."

Human displacement

Hazards resulting from the increasing intensity and frequency of extreme weather events...are **already causing an average of more than 20 million people** to leave their homes and move to other areas in their countries each year."

3

IPCC: Warming Will Very Likely Lead to a Higher Frequency, and Intensity, of Extreme Weather Events

Extreme heat events

Frequency and increase in intensity of extreme temperature event that occurred once in ten years on average in a climate w/out human influence

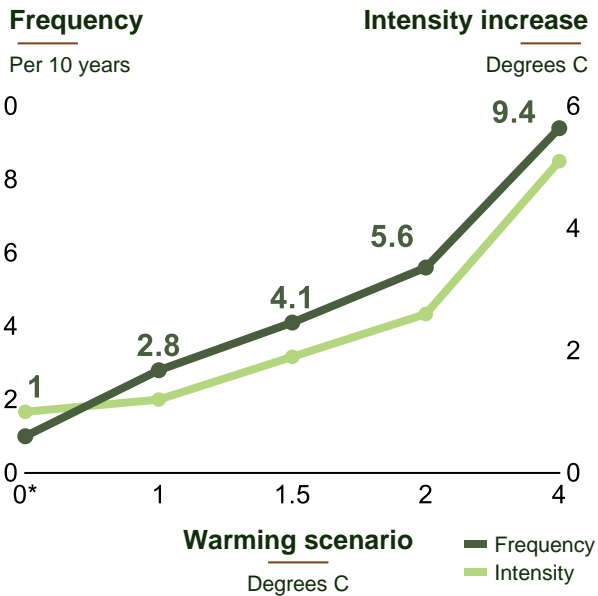

Heavy one-day precipitation events

Frequency and increase in intensity of heavy one day precipitation event that occurred once in ten years on average in a climate w/out human influence

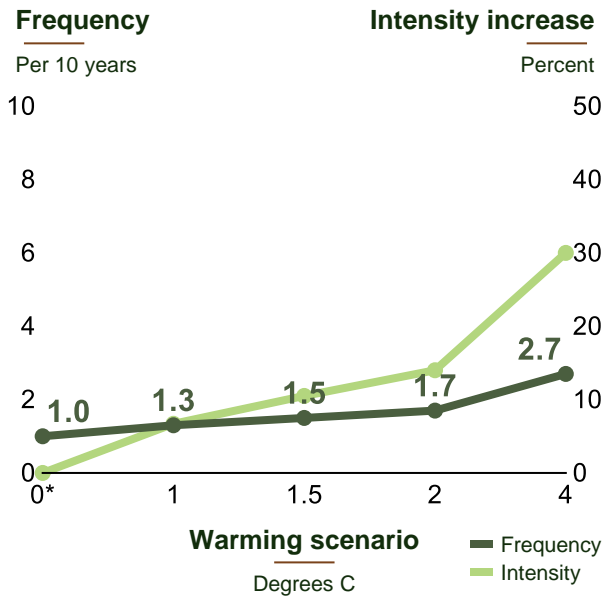

Severe agricultural and ecological drought event

Frequency and increase in intensity of an agricultural & ecological drought event that occurred once in ten years on average across drying regions in a climate w/out human influence

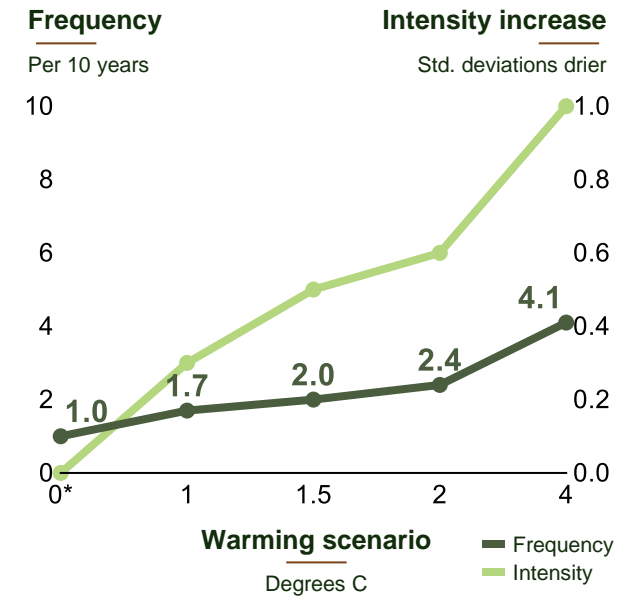

Note: (*) 0 is based on 1850-1900 – all changes are relative to 1850-1900, representing a climate without human influence
 Source: IPCC, Sixth Assessment Report (AR6), *The Physical Science Basis – Summary for Policymakers* (2021), Section B.2

3

Future Risks aren't Uniformly Distributed, With Southeast Asia and Sub-Saharan Africa Disproportionately Exposed

Share of population at high or very high risk

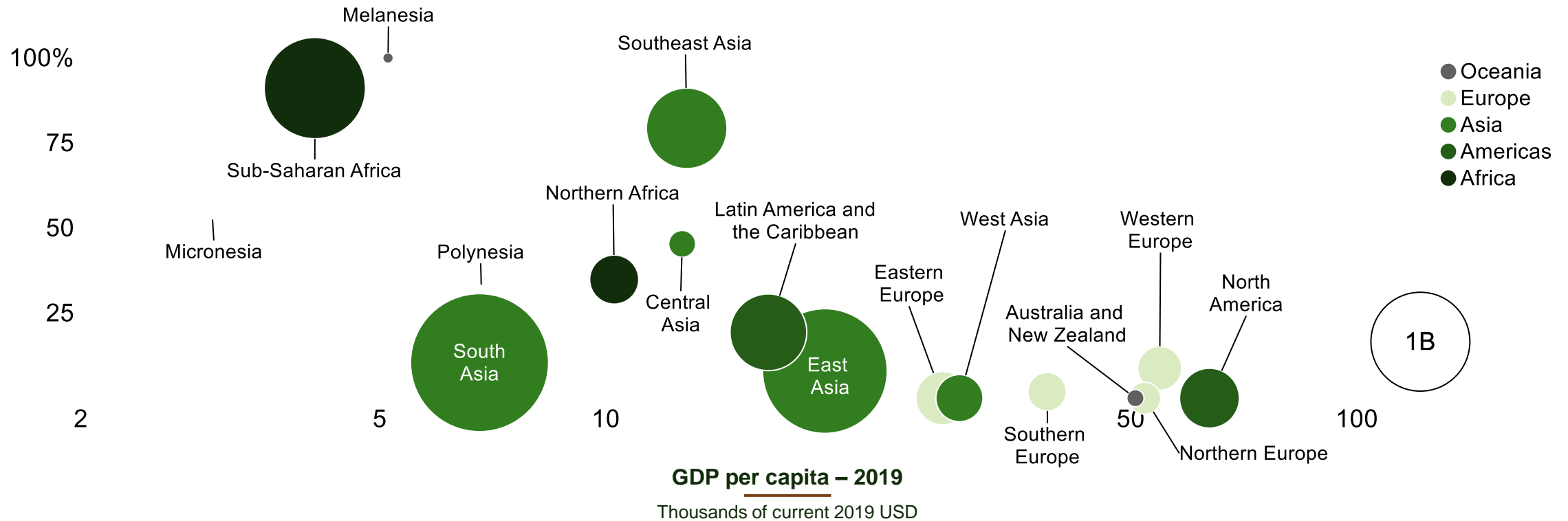

Notes: Share of population at risk based on the WorldRiskIndex, which assesses the risk of disaster as a result of natural hazards, incorporating exposure and vulnerability, and is used by the IPCC to gauge region- and country-level climate change risks; currency is adjusted for purchasing power parity; GDP per capita is shown on a logarithmic scale and is adjusted for purchasing power parity. Sources: IPCC, Sixth Assessment Report; World Risk Report 2021; World Bank

3

The Overall Economic Cost of Continued Warming is Difficult to Estimate but Could Be Substantial

Percent loss in global GDP by 2050

(global GDP losses from rising temperatures, relative to a world without climate change (0°C))

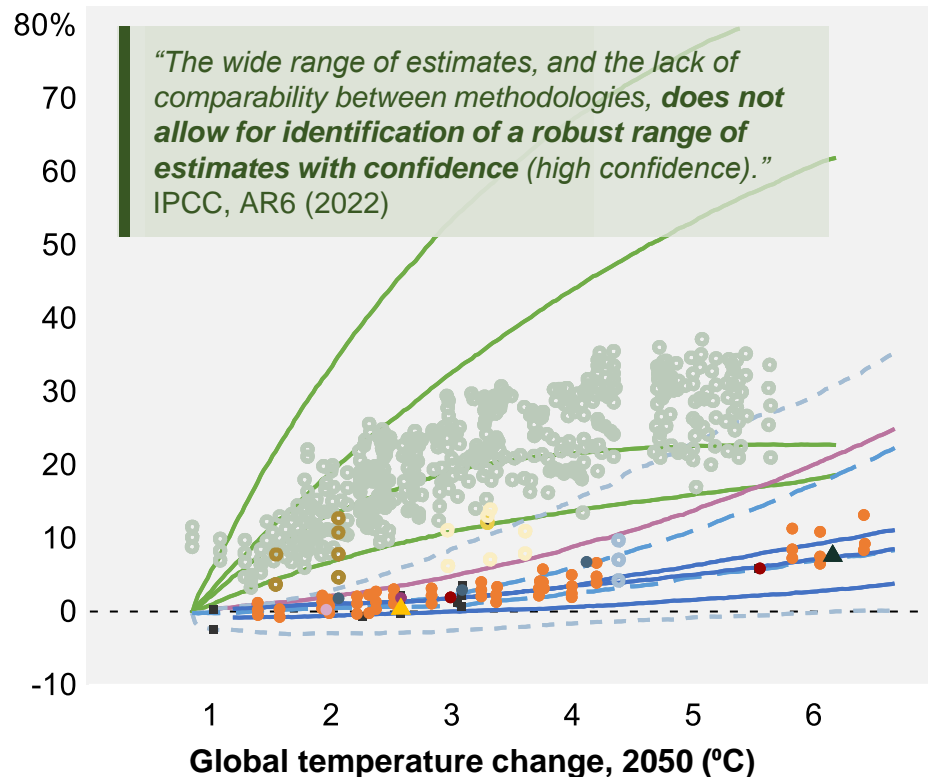

- AR5
- Kahn et al (2019)
- Kalkuhl & Wenz (2020)
- Burke et al (2018)
- Pretis et al (2018)
- Maddison & Rehdanz (2011)
- Burke et al (2015)
- Takakura et al (2019)
- Dellink, Lanzi & Chateau (2019)
- Kompas et al (2018)
- Roson & van der Mensbrugghe (2012)
- Boselo et al (2012)
- Rose et al (2017)
- Rose et al (2017) - FUND 5th & 95th
- Rose et al (2017) - PAGE 5th & 95th
- ▲ Nordhaus & Moffat (2017) / Nordhaus (2015)
- ▲ Tol (2018)
- Howard & Sterner (2017)

Drivers of adverse GDP impact

(non-exhaustive)



Property / infrastructure damage and disruptions to trade flows from sea level rise and more, and more intense, extreme weather events



Reduced working capacity and lower productivity from labor / land due to heat stress and extreme changes in rainfall



Adverse impacts on human health from heat, weather events and climate-related food- and water-borne diseases

Source: IPCC, Sixth Assessment Report (AR6), *Climate Change 2022: Impacts, Adaptation and Vulnerability*, 16-111 (2022)

3

The Tone News Outlets Use to Describe Climate Change Has Become More Urgent

Number of mentions of search term in global online news (thousands of articles)

Climate crisis

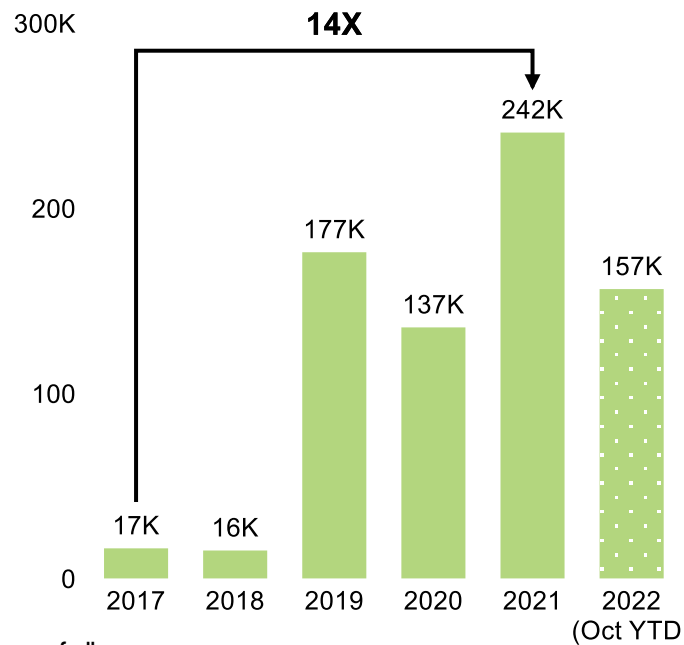

Share of all monitored articles

0.01% 0.01% 0.10% 0.10% 0.20% 0.19%

Climate emergency

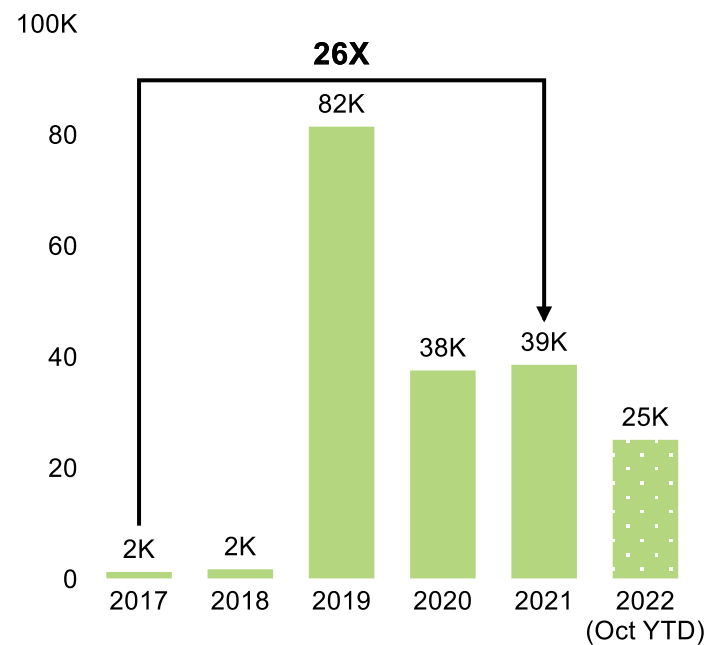

0.00% 0.00% 0.05% 0.03% 0.03% 0.03%

Climate change

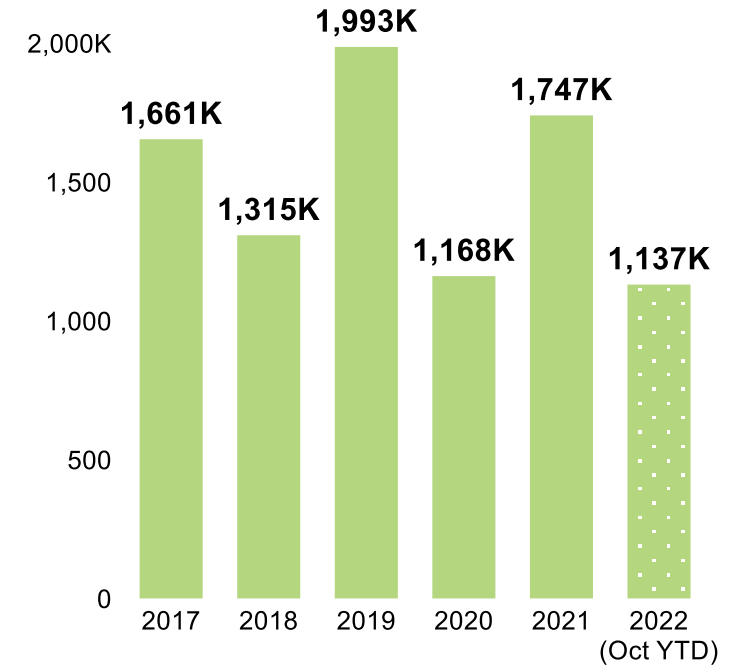

0.73% 0.68% 1.17% 0.85% 1.45% 1.34%

Source: GDELT Online News Summary

In 2023, a Range of Human Activities Resulted in the Release of About 53 Billion Tons of Greenhouse Gases

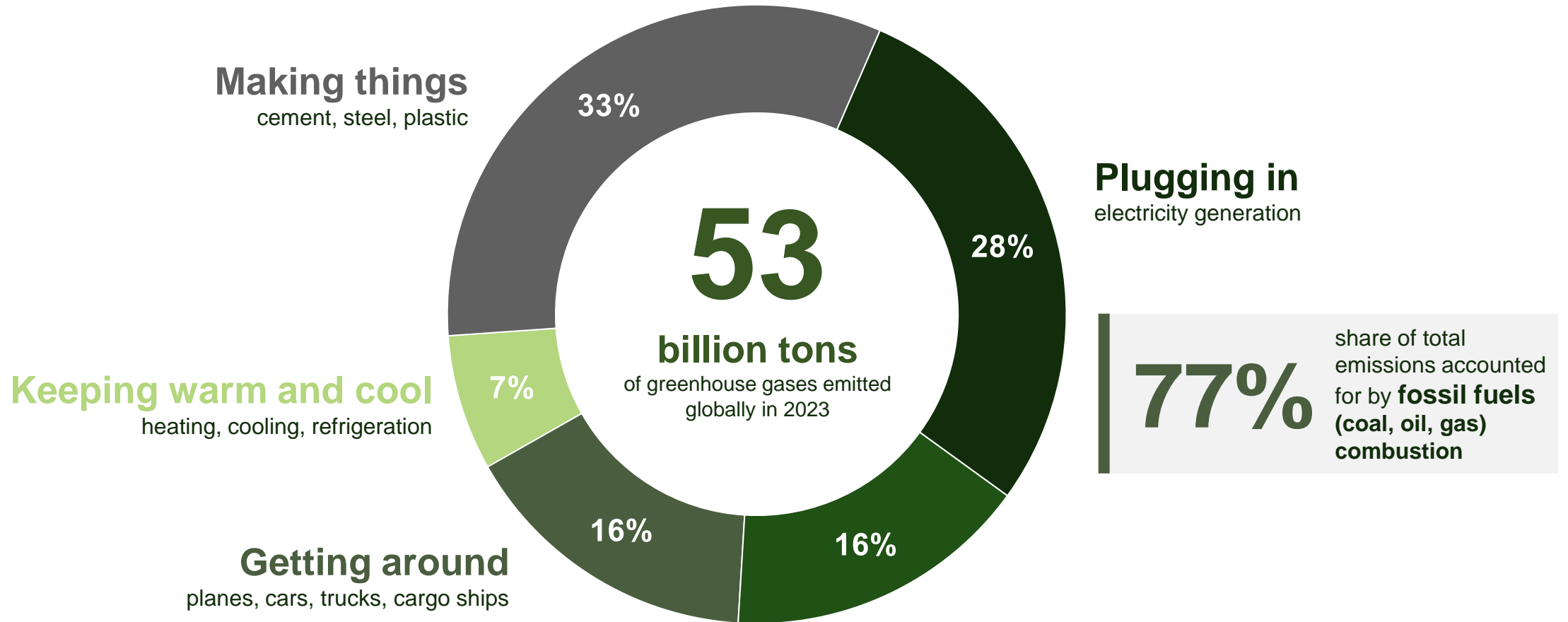

Note: Emissions measured in tons of CO₂-equivalent and include carbon dioxide, methane, nitrous oxide, and f-gases
Source: Bill Gates, *How to Avoid a Climate Disaster* (2021); EDGAR GHG emissions of all world countries, 2024 report

Even One Gigaton is Enormous in Scale

1
gigaton
(or 1 billion metric tons)

2.2
trillion pounds



10,000
fully loaded US aircraft
carriers



400,000
Olympic-sized swimming
pools



~1,100ft
(or 100+ stories) **deep**
covering Central Park

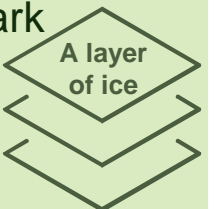

Source: NASA, NOAA

3

Products We Rely On Everyday are Significant Sources of Greenhouse Gas Emissions



Note: Global production values are directional; gasoline intensity is based on burning a gallon of gasoline
 Source: EIA; NIH; USDA; Bill Gates, How to Avoid a Climate Disaster (2021); Poore & Nemecek (2018); Portland Cement Association; UN Environment Programme

3

In Electricity Generation, Greenhouse Gas Emission Intensity Varies Widely by Generation Source

Lifecycle greenhouse gas emissions

(measured in g of CO₂ - equivalent per kWh)

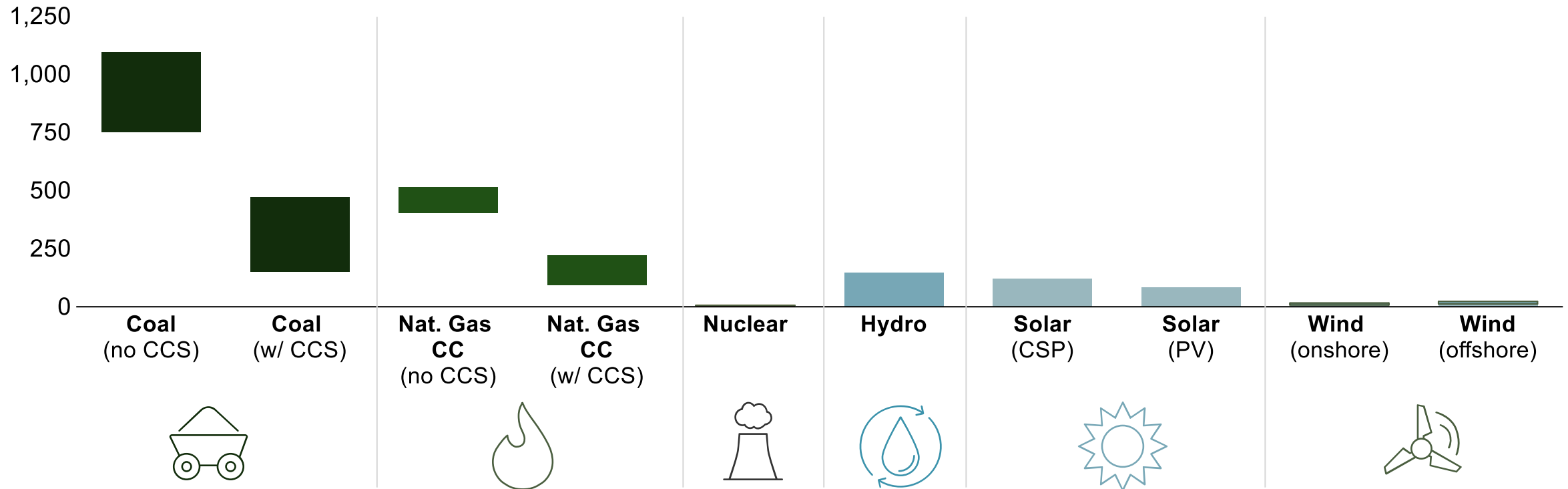

Note: CCS = Carbon Capture & Storage, CC = Combined Cycle, CSP = Concentrating Solar-Thermal Power, PV = Photovoltaic
 Source: UN Economic Commission for Europe, Life Cycle Assessment of Electricity Generation Options (2021)

3

Anthropogenic GHG Emissions Have Grown Steadily and are 50% Higher Today Than They Were in 1990

Annual global greenhouse gas emissions by sector

(measured in billions of tons of CO₂-equivalent)

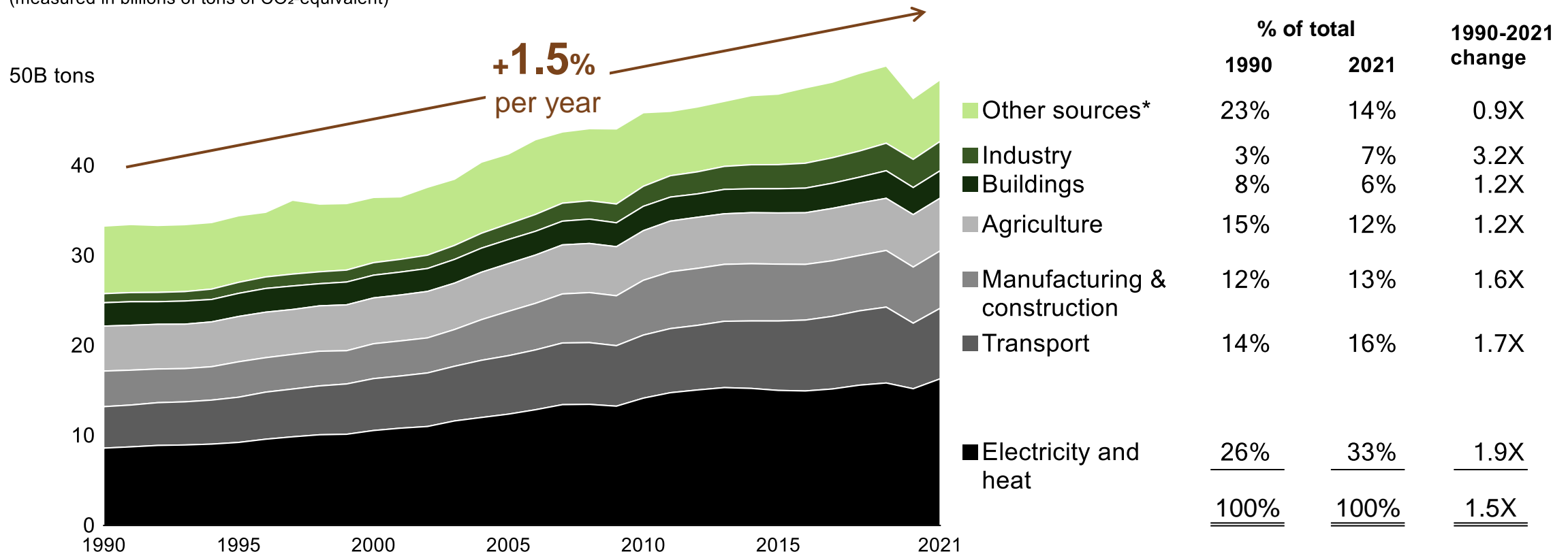

Note: * Other includes aviation / shipping, land-use change and forestry, waste, fugitive emissions, and other fuel combustion. Emissions source mix differs vs. prior pages due to categorization differences. For example, "Industry" and "Manufacturing & construction" are broken out separately here, versus included together in "Making things". Source: Climate Watch

3

The Top 10 Emitting Countries Account for Over Two-Thirds of Global GHG Emissions, China and the US Alone Nearly 40%

Greenhouse gas emissions by continent and country, 2022

(measured in billions of tons of CO₂-equivalent; includes non-CO₂ GHG emissions like methane)

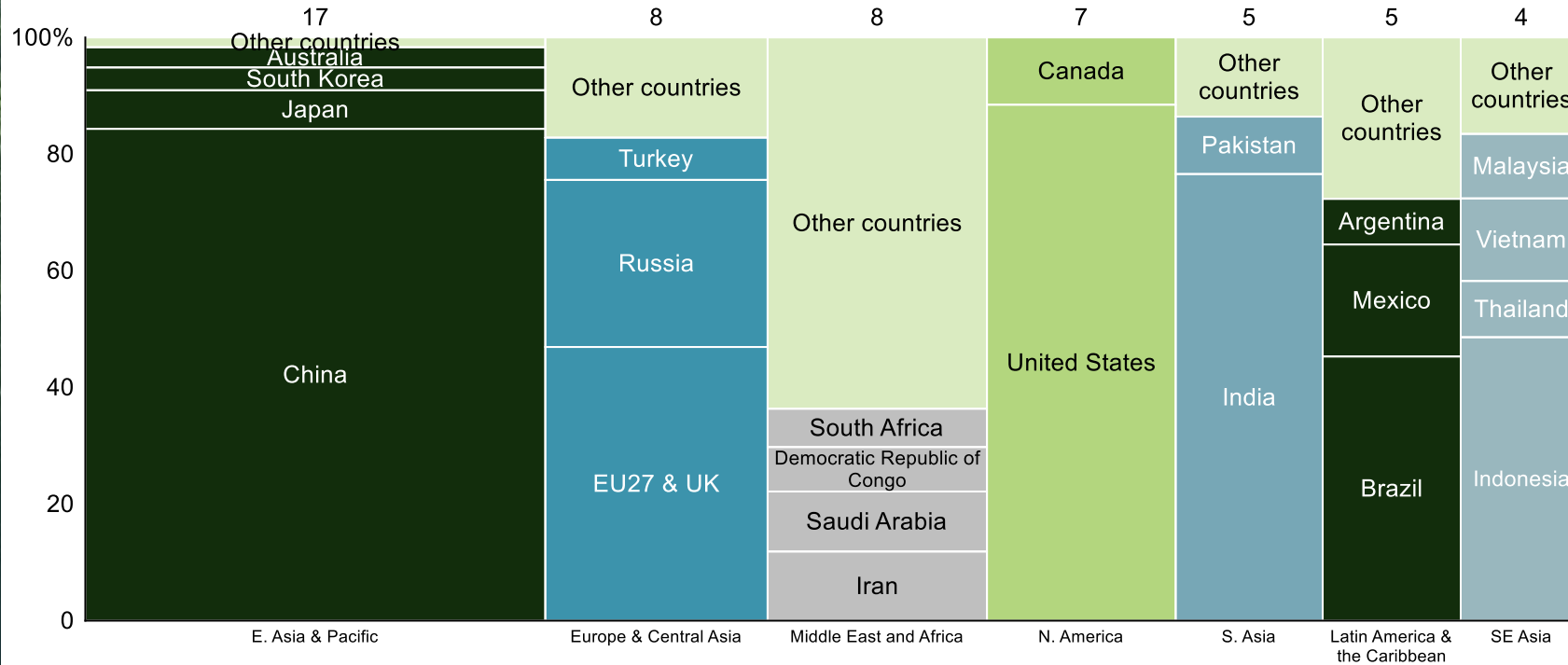

Top 10 global emitters

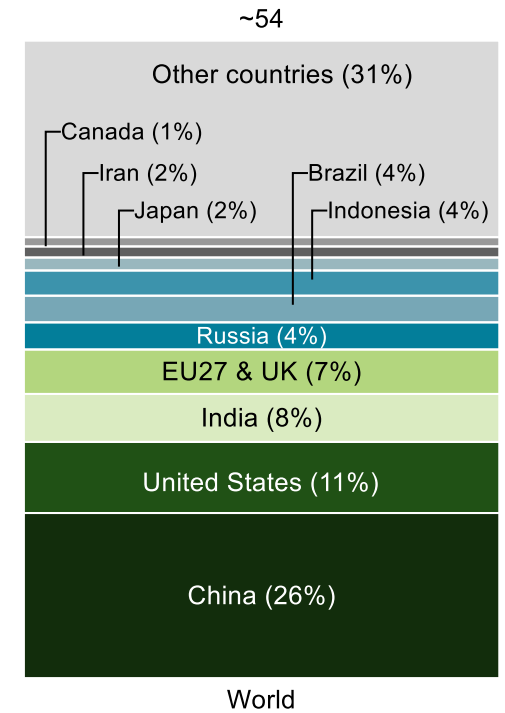

Note: * Other countries include those with <400M tons of CO₂- equivalent emissions in 2018. Emissions from international aviation and shipping included in "other countries" in right-side chart. Source: Climate Watch; Our World in Data

3

Emissions Sources Vary Materially From Country to Country

Greenhouse gas emissions by sector, 2019

(measured in billions of tons of CO₂-equivalent; includes non-CO₂ GHG emissions like methane)

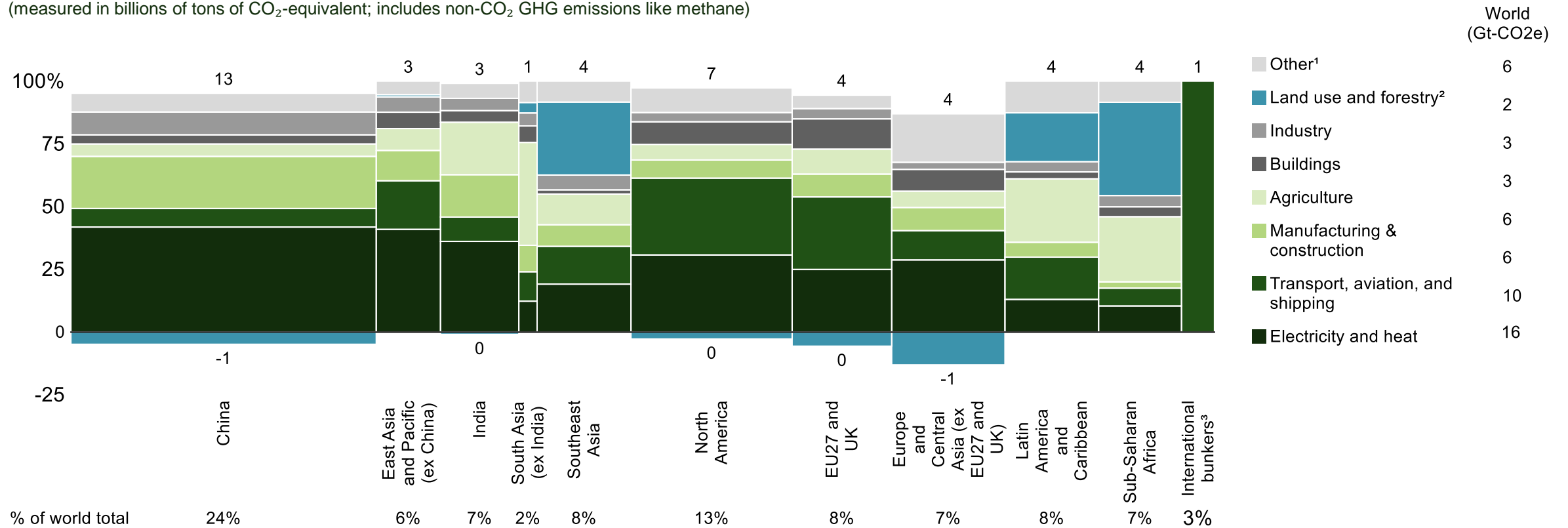

Note: (1) "Other" includes waste, fugitive emissions, and other fuel combustion. (2) Land use and forestry emissions reflect the emission (via deforestation, conversion of other natural ecosystems to agriculture, etc.) or sequestration (via reforestation, afforestation, wetland restoration, grassland restoration, etc.) of carbon through human activities. (3) International bunkers comprises emissions associated with international aviation and marine transportation.

Source: Climate Watch; Our World in Data; IPCC, Sixth Assessment Report (AR6), Working Group III, Chapter 7

Asia Accounts for Nearly 60% of Anthropogenic CO₂ Emissions Today

Annual CO₂ emissions by country or region

(PRODUCTION-BASED EMISSIONS OF CARBON DIOXIDE [CO₂], MEASURED IN MILLION TONS. THIS IS BASED ON TERRITORIAL EMISSIONS, WHICH DO NOT ACCOUNT FOR EMISSIONS EMBEDDED IN TRADED GOODS. EXCLUDES NON-CO₂ EMISSIONS)

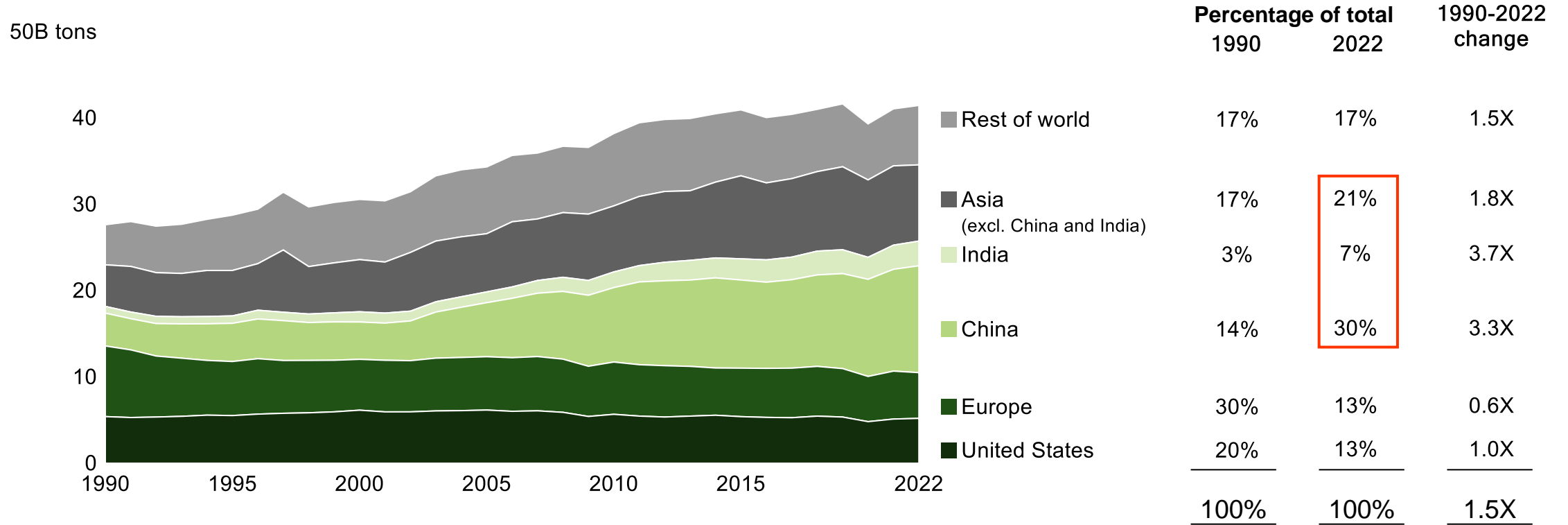

Note: Includes CO₂ emissions from fossil fuels and land use change
 Source: Global Carbon Project; Our World In Data

Since 1990, Non-OECD Countries Have Driven All Global Anthropogenic CO₂ Emissions Growth

Gigatons of CO ₂ ¹	1990		2022		Share of 1990-2022 growth
	Emissions	% of total	Emissions	% of total	
United States	5.4	20%	5.2	12%	(1%)
EU – 27	3.7	13%	2.6	6%	(8%)
Other OECD	3.7	13%	4.8	12%	8%
Total OECD	12.8	46%	12.6	30%	(1%)
China	3.8	14%	12.4	30%	62%
India	0.8	3%	2.9	7%	15%
Other non-OECD	10.2	37%	13.6	33%	24%
Total non-OECD	14.8	54%	28.9	70%	101%
World	27.6	100%	41.5	100%	100%

Note: (1) Emissions are production-based and include emissions from energy and land-use change, measured in gigatons of CO₂
Source: Global Carbon Project

3

But on a Cumulative Basis, the US and Europe Have Contributed Much More to Increased Atmospheric CO₂ Concentration

Cumulative global CO₂ emissions from energy and land use change

cumulative production-based emissions of carbon dioxide [CO₂] since the first year of data available, measured in million tons. This is based on territorial emissions, which do not account for emissions embedded in traded goods. Excludes non-CO₂ emissions

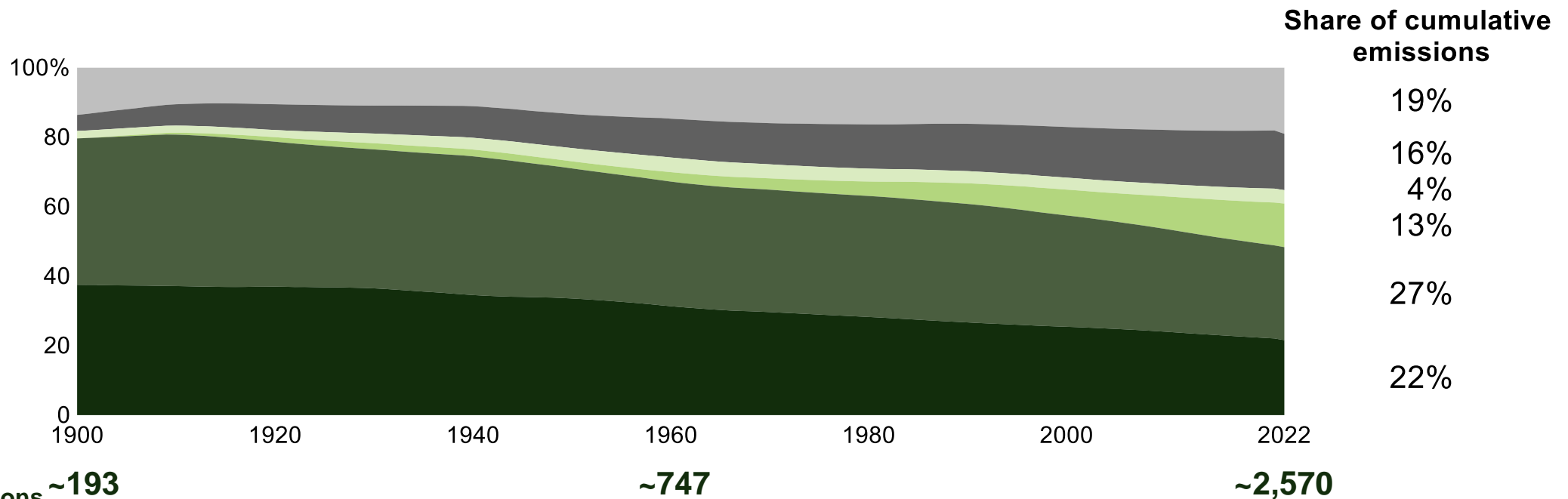

Cumulative global emissions ~193

~747

~2,570

Billions of tons since 1850

Note: Includes CO₂ emissions from fossil fuels and land use change
Source: Global Carbon Project; Our World In Data

United States China
Europe India
Rest of the world Rest of Asia

Similarly, Energy Consumption is Highly Correlated With Economic Progress—and There is Still Considerable Inequality

CO₂ emissions per capita, 2019

(consumption-based emissions [i.e., adjusted for trade], measured in tons per person)

20 tons

15

10

5

0

500

1,000

2,000

5,000

10,000

20,000

50,000

100,000

GDP per capita, 2019

(measured in constant 2017 international dollars. Logarithmic axis)

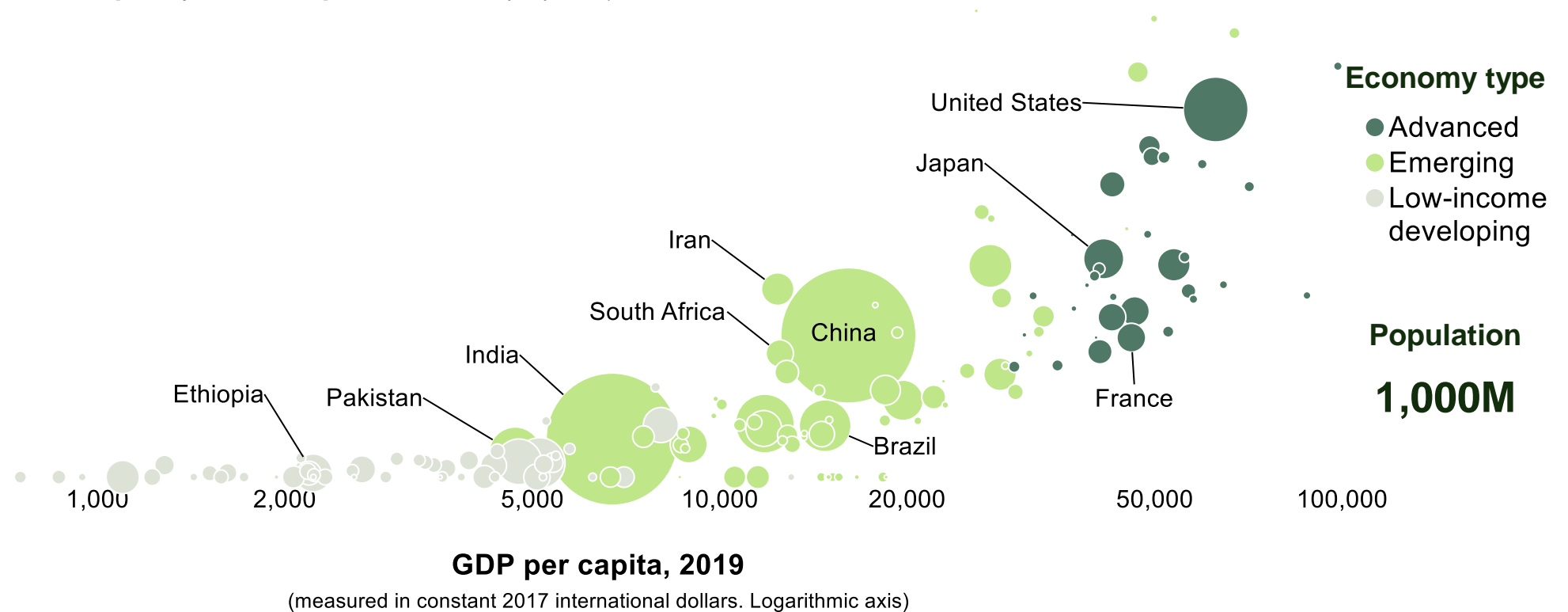

But the Emissions Intensity of GDP has Fallen Significantly

41%

decline in CO₂ emissions per dollar of GDP over 1990-2019. Drivers include **coal-to-gas switching** and **increased energy efficiency** in power generation and industrial processes, and today, in over 30 countries including the US, **economies are growing while emissions fall**

Global emissions intensity of GDP

(measured in tons of CO₂ per thousand 2015 PPP-adjusted USD; excludes non-CO₂ GHG emissions like methane)

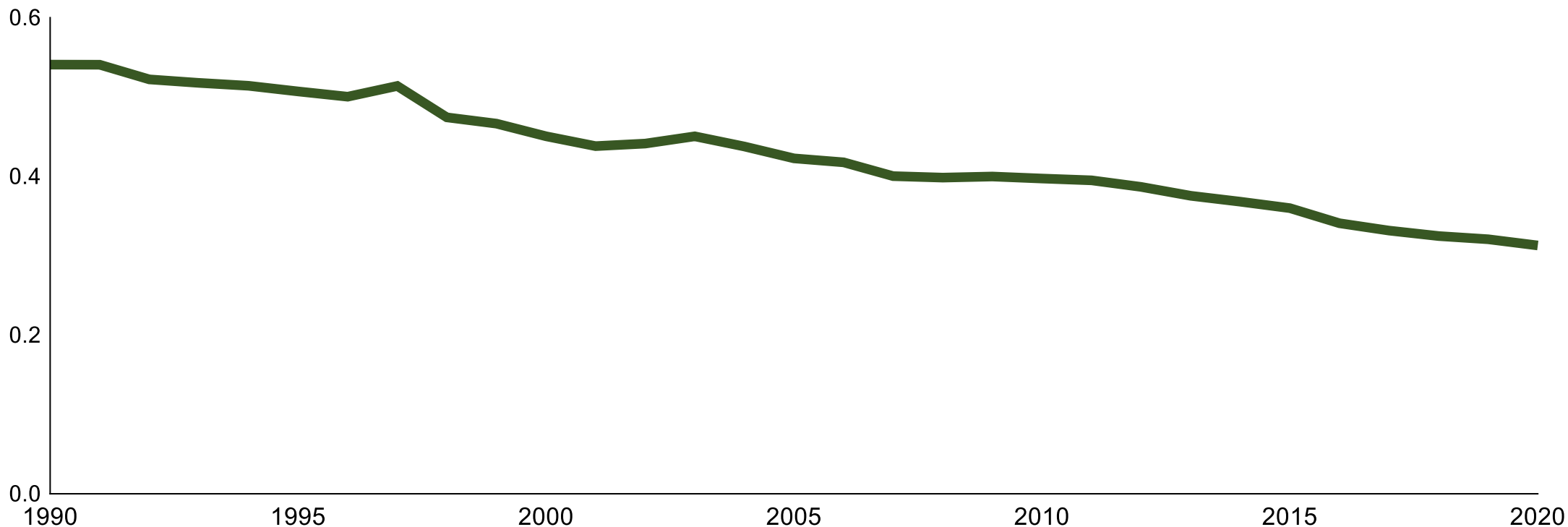

Note: Includes CO₂ emissions from fossil fuels and land use change

Source: Our World in Data; Global Carbon Project; Maddison Project Database 2020; Climate Action Tracker; The Breakthrough Institute

3

To Limit Warming, Greenhouse Gas Emissions Will Need to Decline Significantly in the Coming Years

Global primary energy demand

PETAWATT-HOURS

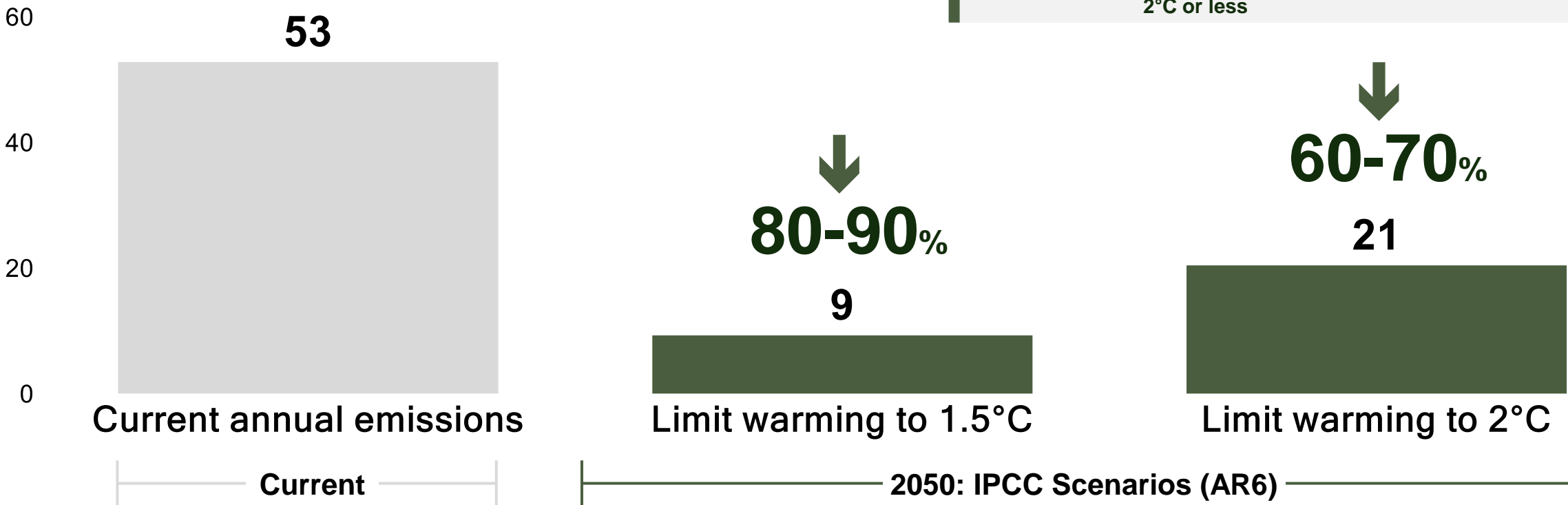

Note: ">50%" and ">67%" refer to probability of reaching scenario should emissions reduction targets be reached

Source: IPCC, Sixth Assessment Report (AR6), Climate Change 2022: *Mitigation of Climate Change – Summary for Policymakers*, Table SPM.1 (2022); Climate Action Tracker (updated Nov 2021); EDGAR *GHG emissions of all world countries, 2024 report*

Climate Change: Fundamentals and Possible Trajectories



The atmospheric concentration of greenhouse gases (GHGs), such as CO₂, affects the earth's climate



Human activity has led to the release of more than two trillion tons of CO₂ into the atmosphere since 1850



This release has been an important driver of an observed increase in average global surface temperature vs. pre-industrial times



Warming contributes to rising sea levels and increases the likelihood and severity of certain types of extreme weather



The combustion of fossil fuels (for a variety of end uses) is the largest, but not only, source of emissions



Today, Asia is the largest greenhouse gas emitter; China and the US alone account for almost 40% of the global total



But the US and Europe cumulatively emitted much more over the past century than did any other region



To mitigate the risk of climate change, GHG emissions must decline significantly, and ideally reach net zero, within a few decades

Agenda

An aerial photograph of a wind turbine in a lush green field. The turbine is white with three blades, one of which is pointing towards the top right. The field is divided into sections by thin lines, possibly roads or irrigation channels. The overall scene is bright and clear.

01

OpenMinds
and the Dual
Challenge:
Executive
Summary

02

Energy: Uses,
Sources, and
Outlook

03

Climate
Change:
Fundamentals
and Possible
Trajectories

04

**Reality Check:
Where We Are
Today**

05

The Dual
Challenge:
Headwinds
and Tailwinds

Reality Check: Where We Are Today

- Over the last half-century (since 1970), global population doubled, and overall GDP nearly quintupled
- As GDP per capita increased, so did energy consumption per capita (offset somewhat by efficiency gains)
- Altogether, driven by population and income, and somewhat offset by efficiency gains, total energy consumption tripled in the last 50 years
- To meet that tripling, the global energy supply mix changed only slightly, and today, we remain heavily reliant on fossil fuels
- Emissions increased alongside energy supply, doubling since 1970, and we have yet to “bend the curve”
- There is still considerable economic and energy inequality around the world today
- Emerging economies will need significantly more energy over the next decades to support development

The bottom line: We must meet the growing demand for energy while reducing greenhouse gas emissions, with the aim of enhancing the wellbeing of humans everywhere.

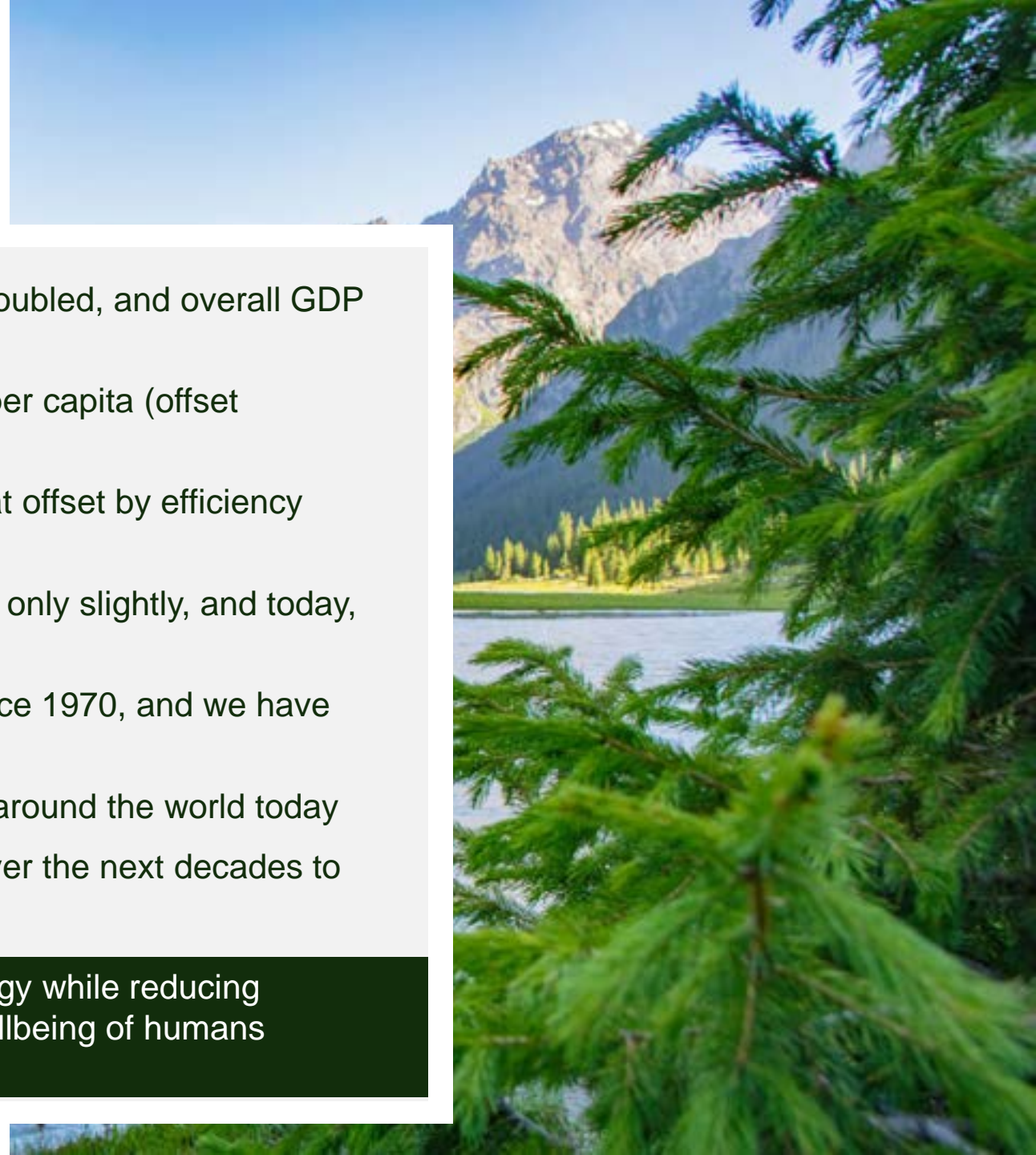

4

Since 1970, the Global Population Doubled in Size

Global population

(shown as line, measured in billions of people)

Population, annual growth

(shown as bars)

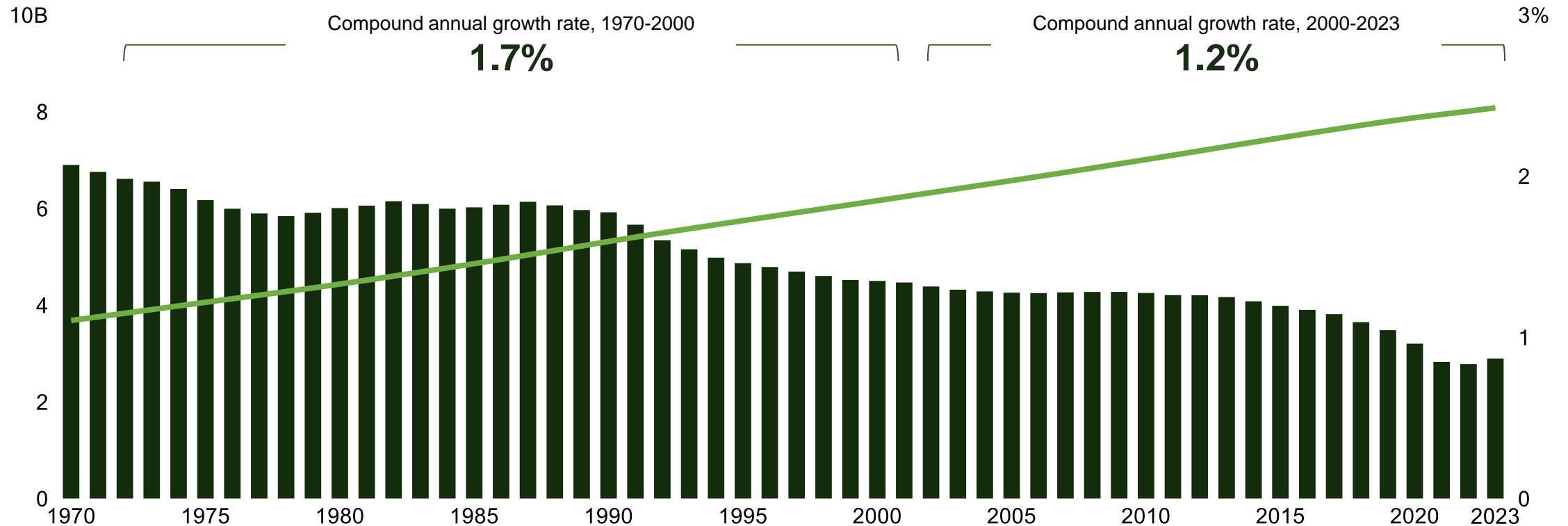

Source: Our World in Data; World Bank

4

During that Time, Global GDP Quintupled, and GDP Per Capita More than Doubled

Global GDP

(trillions of constant 2015 US\$)

5.1X

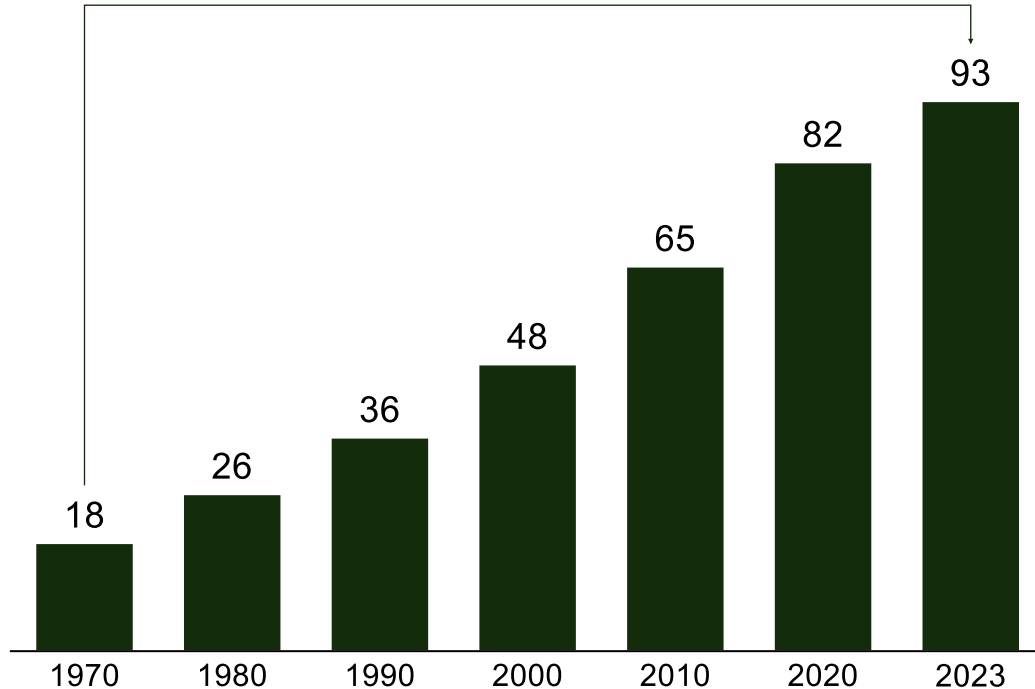

Global GDP per capita

(trillions of constant 2015 US\$ per person)

2.3X

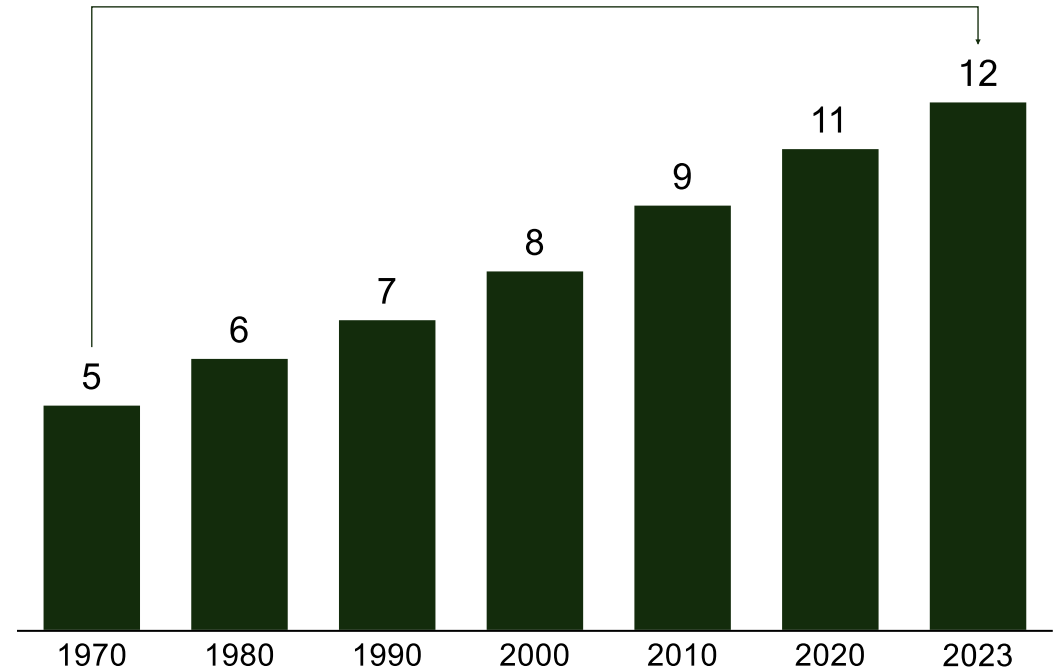

Note: Data are in constant 2015 prices, expressed in U.S. dollars. Dollar figures for GDP are converted from domestic currencies using 2015 official exchange rates.
 Source: Our World in Data; World Bank

4

As GDP Per Capita Increased, so did Energy Consumption, Offset Somewhat by Efficiency Gains

Global primary energy consumption per capita

(megawatt-hours per person per year)

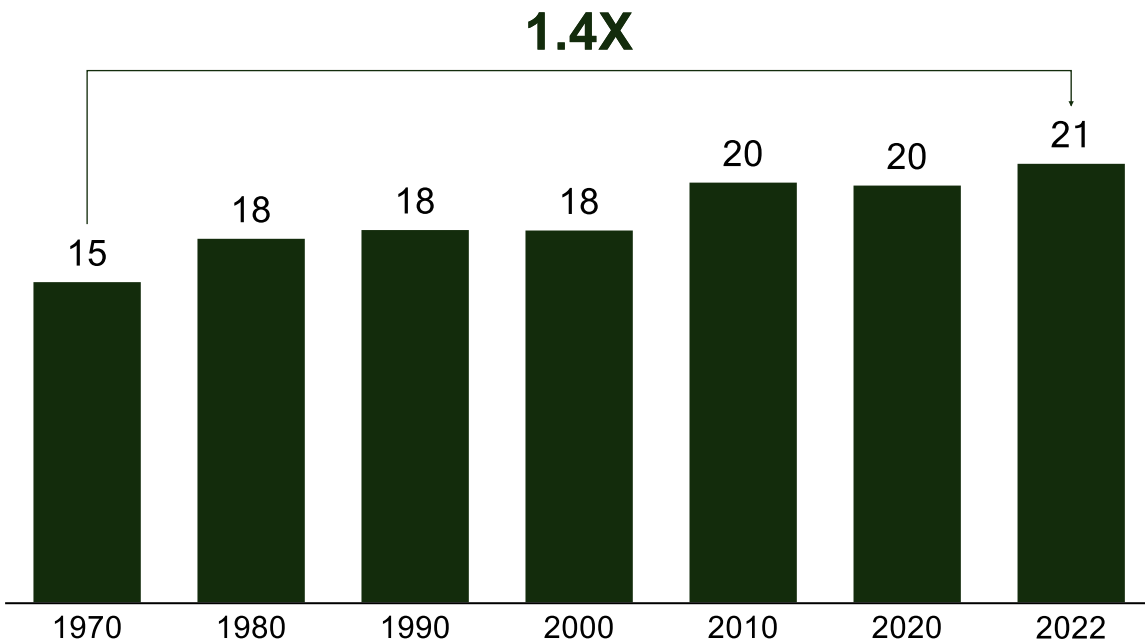

Global primary energy intensity

(kilowatt-hours per dollar of GDP in constant 2011 US\$)

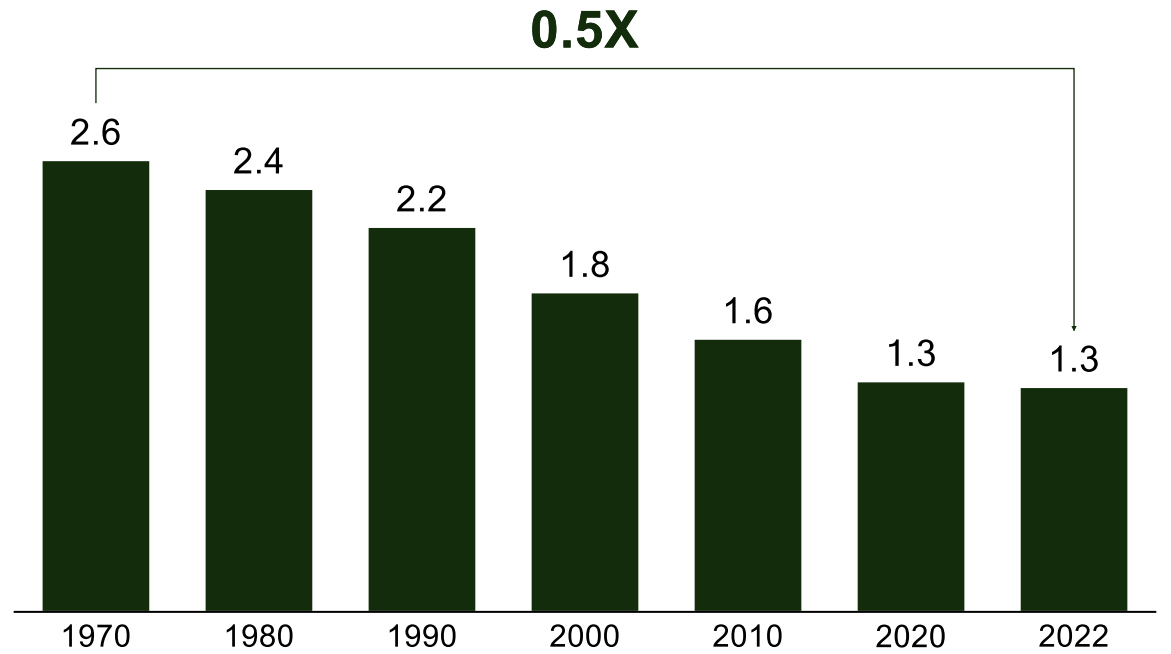

Note: Data are in constant 2015 prices, expressed in U.S. dollars. Dollar figures for GDP are converted from domestic currencies using 2015 official exchange rates.
 Source: Our World in Data; World Bank; BP Statistical Review of World Energy, 2021

Altogether, Annual Global Energy Consumption Nearly Tripled in the Last 50 Years

Annual global primary energy consumption

(shown as line, measured in petawatt-hours)

Primary energy consumption, annual growth

(shown as bars)

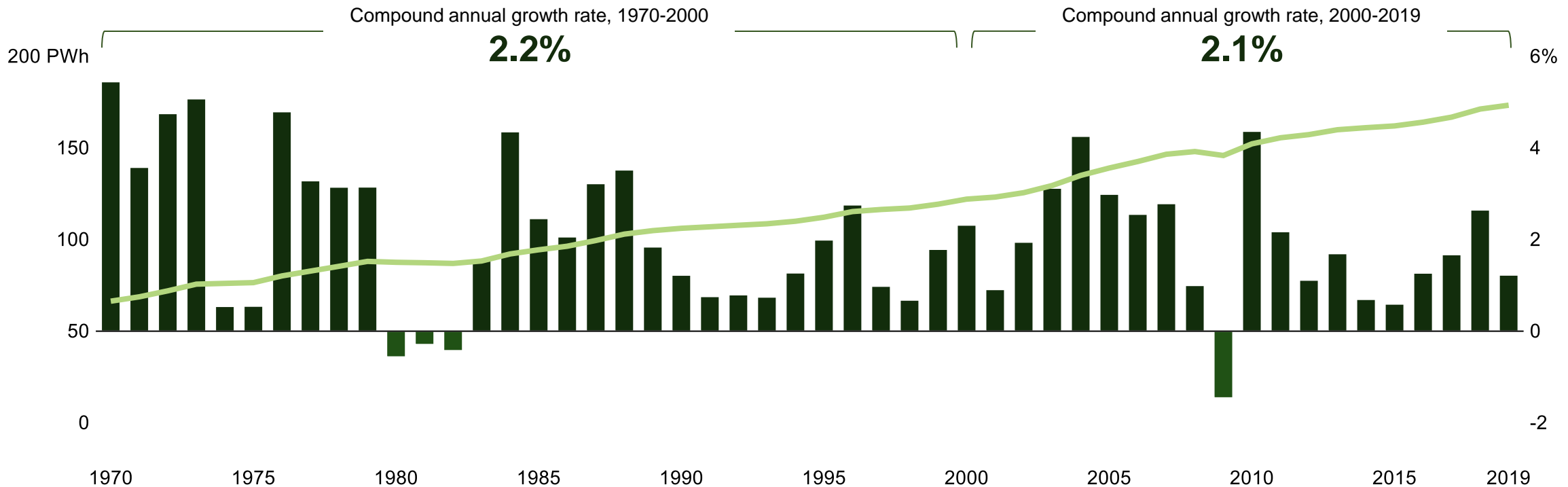

Note: Primary energy includes both commercially-traded fuels, including modern renewables used to generate electricity, and traditional biomass (~10k TWh in 2019)
 Source: BP Statistical Review of World Energy, 2021

4

The Global Energy Mix Changed Only Modestly to Meet the Tripling in Energy Consumption

Global primary energy consumption by source, 1970-2023

(measured in petawatt-hours)

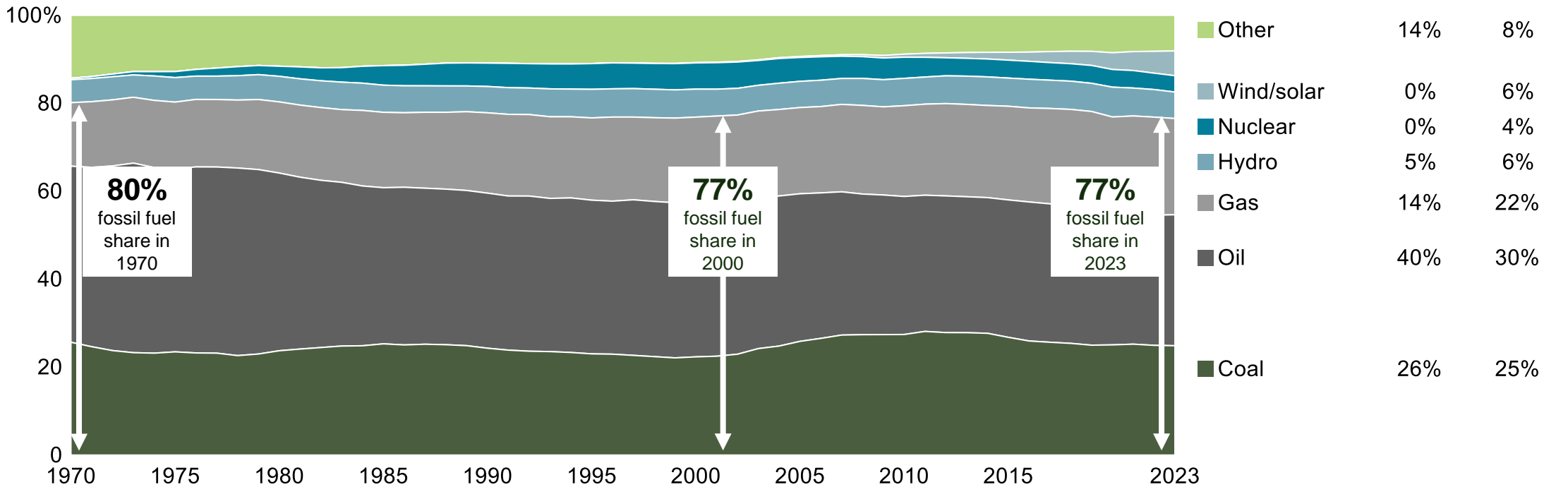

Note: "Other" includes other renewables, biofuels, and traditional biomass

Source: Our World in Data; Vaclav Smil, Energy Transitions: Global and National Perspectives (2017); BP Statistical Review of World Energy, 2021

Annual CO₂ Emissions Also Steadily Increased Over the Last Five Decades, Roughly Doubling

Annual global CO₂ emissions from industry and land use change

(shown as line, measured in billions of tons of CO₂)

CO₂ emissions, annual growth

(shown as bars)

50 GtCO₂

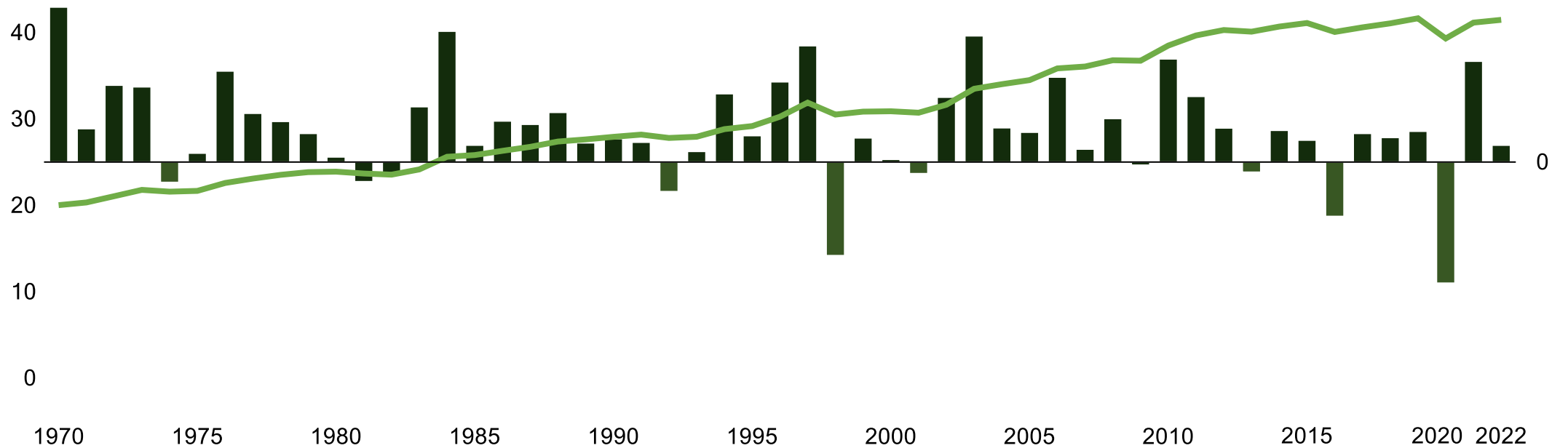

Note: Includes CO₂ emissions from land use change and the burning of fossil fuels for energy and cement production; excludes non-CO₂ greenhouse gases, including methane
 Source: Our World in Data; Global Carbon Project

4

Emissions Per Capita is About the Same as it was in 1970, While Emissions Intensity More Than Halved

Global CO₂ emissions per capita

(tons of CO₂ per person per year)

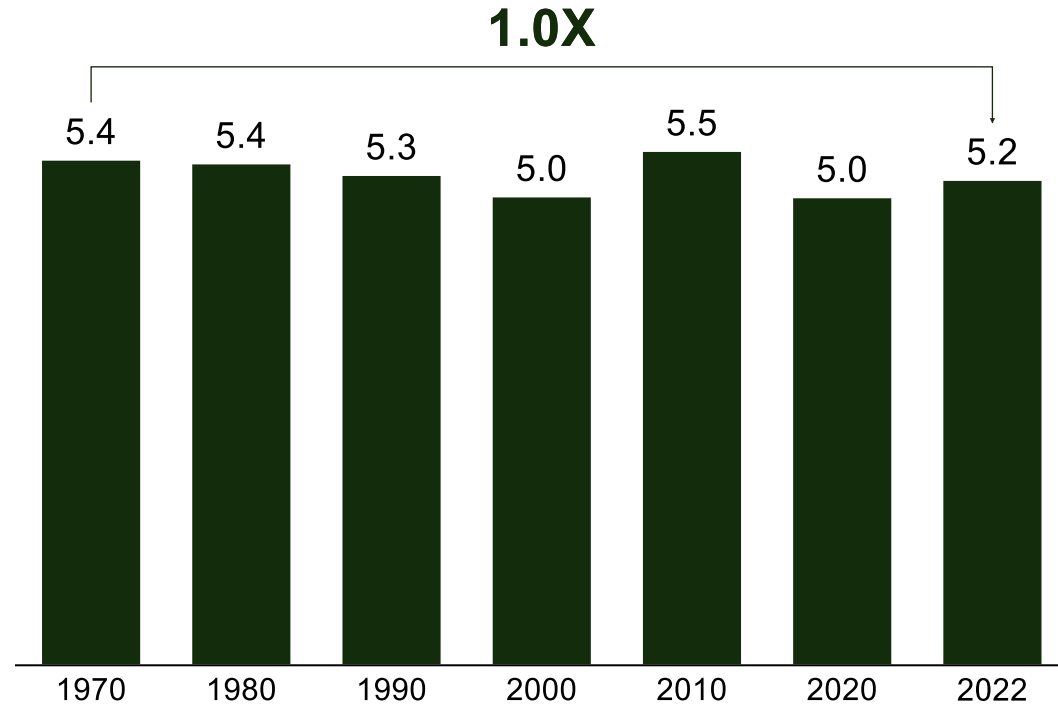

Global CO₂ emissions intensity

(kg of CO₂ per dollar of GDP in constant 2011 US\$)

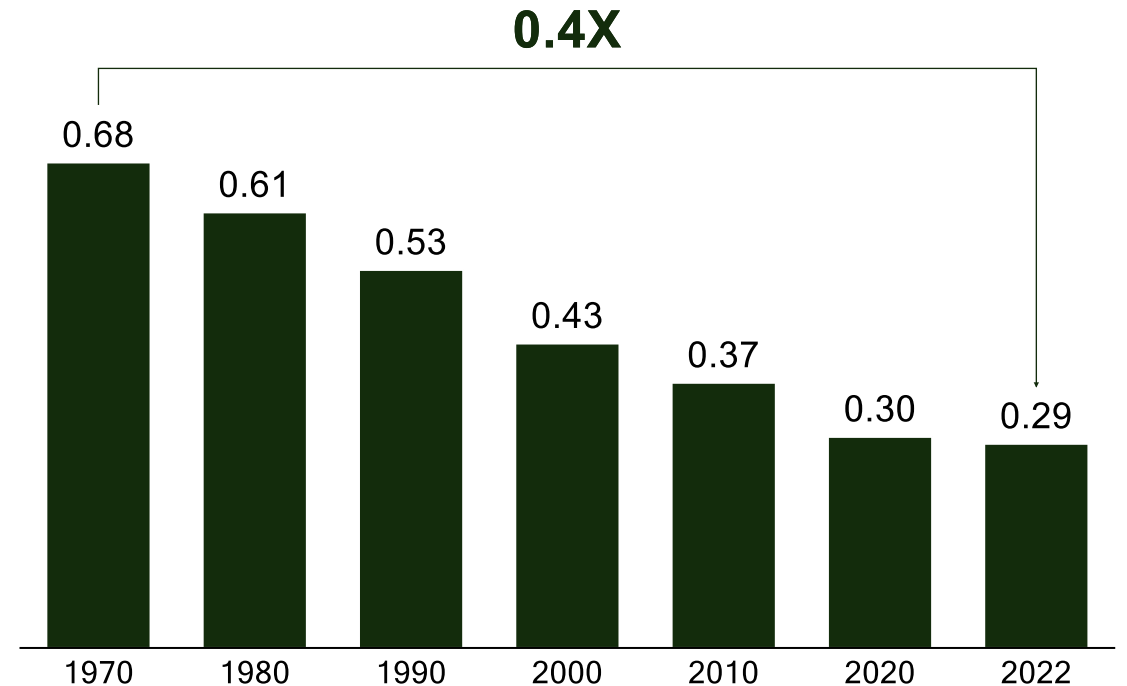

Note: Data are in constant 2015 prices, expressed in U.S. dollars. Dollar figures for GDP are converted from domestic currencies using 2015 official exchange rates.
 Source: Our World in Data; World Bank

CO₂ Emissions Growth was Concentrated in China and the Developing World Over the Last 30 Years

Annual CO₂e emissions by country or region¹
(measured in billions of tonnes of CO₂e)

■ 1990 ■ 1995 ■ 2000 ■ 2005 ■ 2010 ■ 2015 ■ 2022

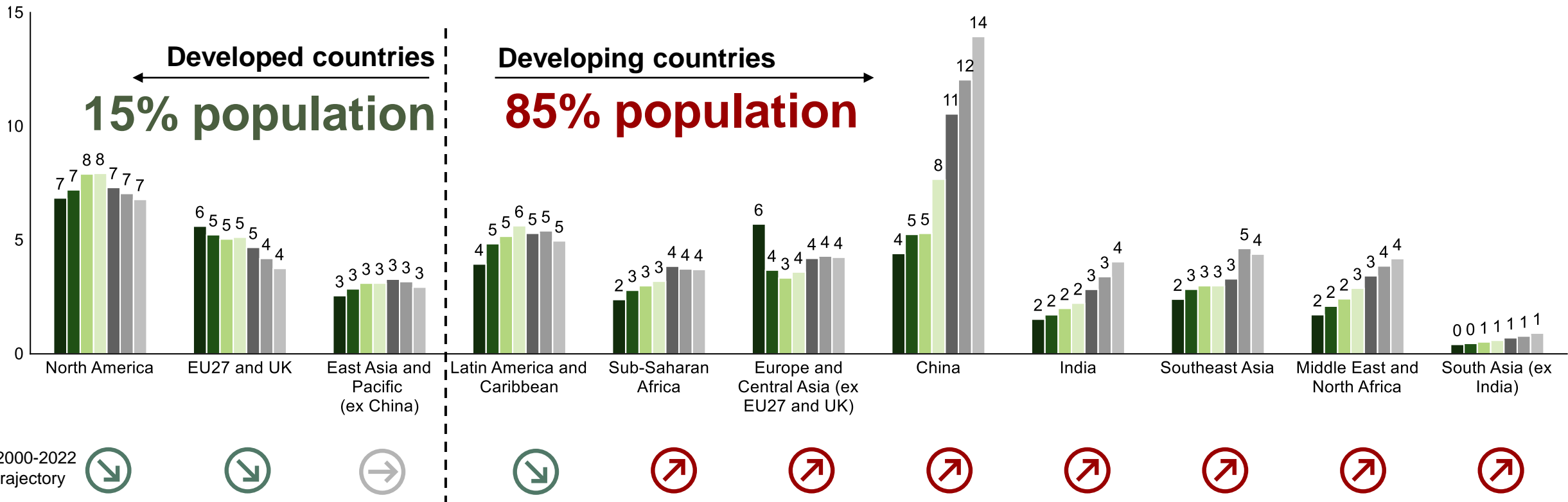

Note: (1) Emissions include carbon dioxide, methane, and nitrous oxide from all sources, including land-use change
Source: Our World in Data

Today, There is Still Considerable Economic and Energy Inequality

Primary energy consumption per capita – 2019

(megawatt-hours per person)

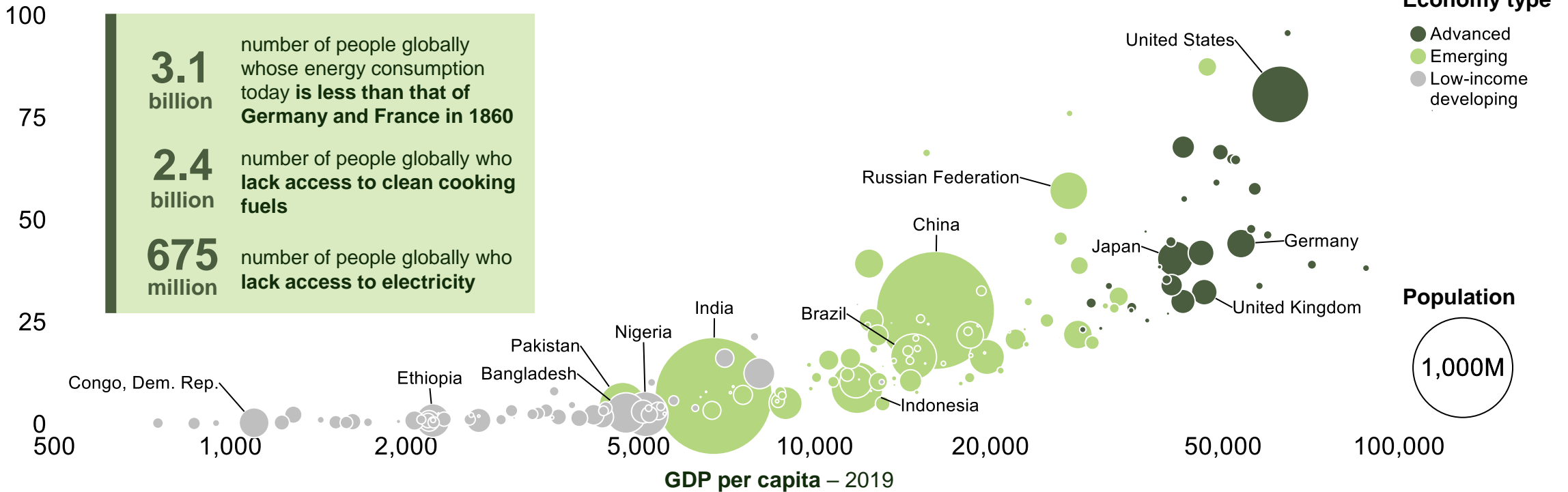

Source: Our World in Data; World Bank; IMF; Global Carbon Project; Vaclav Smil, How the World Really Works

4

And Future Population Growth will Be Concentrated in the Least Developed, Lowest Energy Consumption Regions

Global population by economy type, 2022-2050

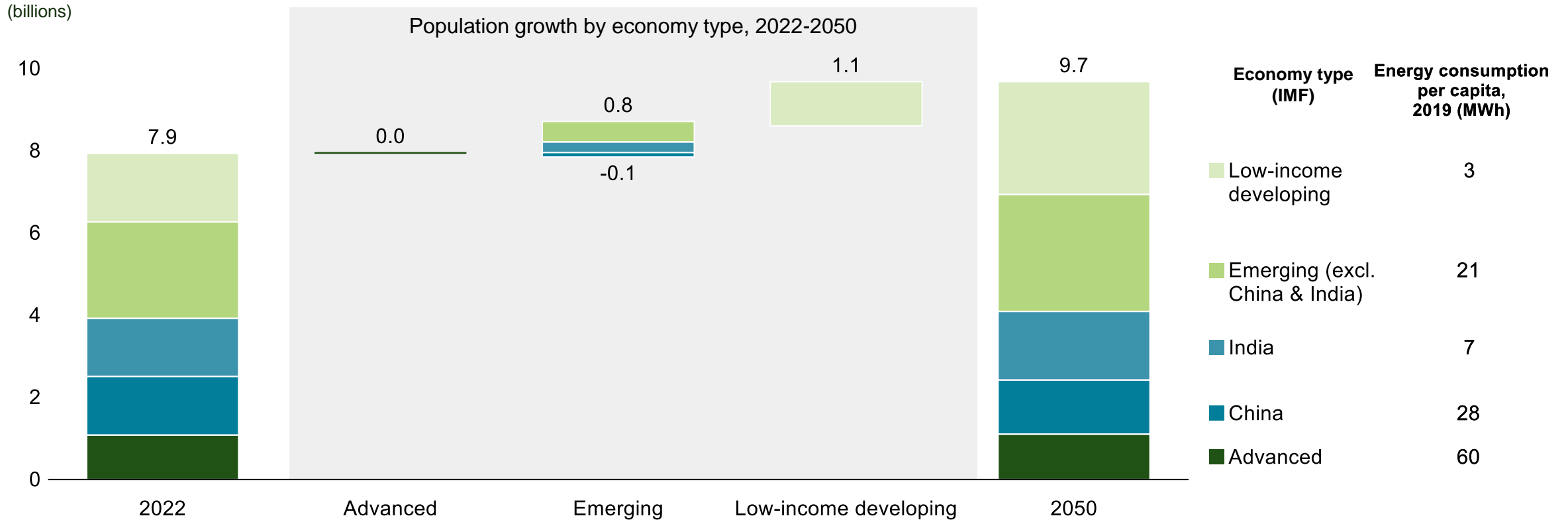

Note: See appendix for country to economy type mapping
 Source: Our World in Data; UN Population Division; BP Statistical Review of World Energy, 2021; IMF

4

An Entire World's Worth of Future Energy Demand Could Come From Countries Still Suffering From Energy Poverty

Primary energy demand in countries that consume <15 MWh per capita today

(2021-2050, petawatt-hours)

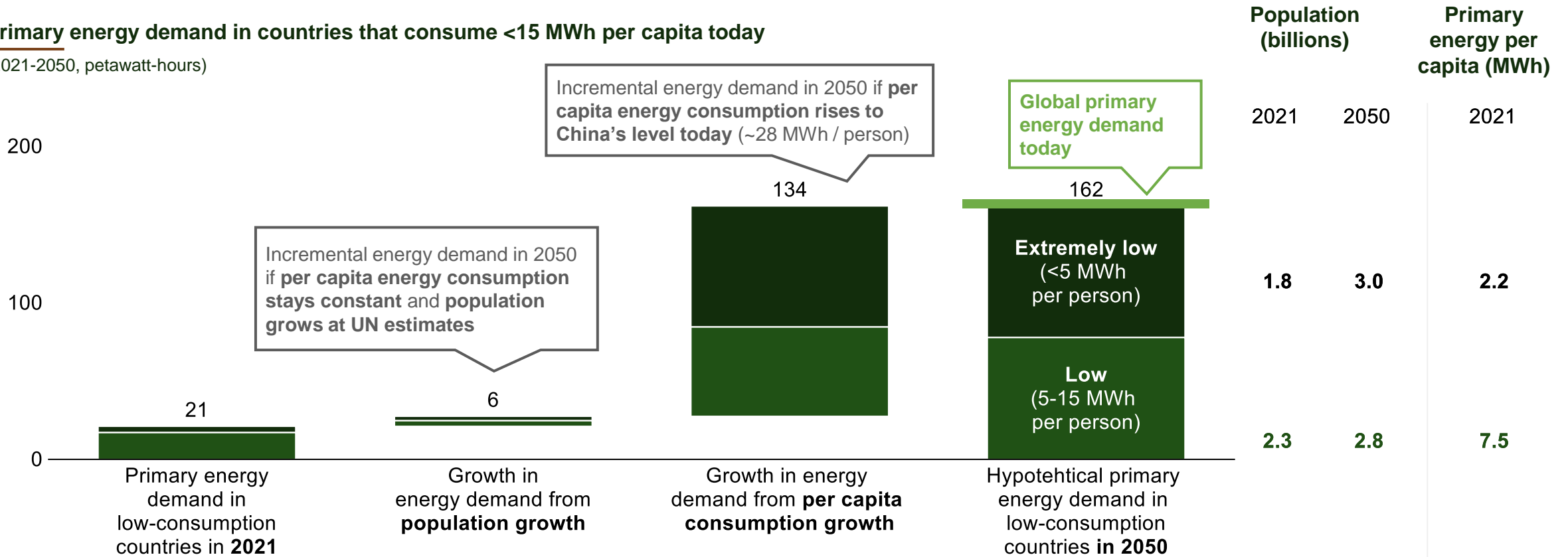

Incremental energy demand in 2050 if per capita energy consumption rises to China's level today (~28 MWh / person)

Incremental energy demand in 2050 if per capita energy consumption stays constant and population grows at UN estimates

Global primary energy demand today

Extremely low (<5 MWh per person)

Low (5-15 MWh per person)

Source: Our World in Data; UN Population Division (medium estimates); BP Statistical Review of World Energy, 2021; IMF

So Far, Only Advanced Economies Have Decoupled Economic Growth From Energy Consumption and Emissions

Primary energy consumption per capita

(MWh. Only 1990, 2000, 2010, and 2019 plotted for each country)

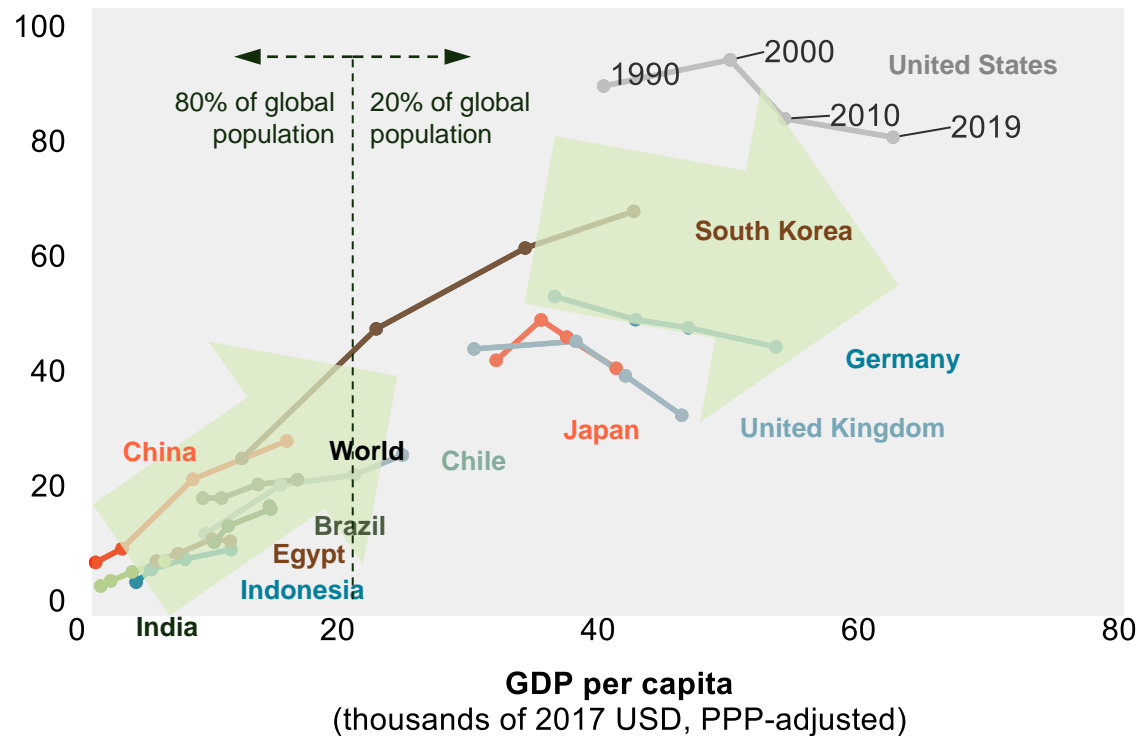

CO₂ emissions per capita

(Tons of CO₂*. Only 1990, 2000, 2010, and 2019 plotted for each country)

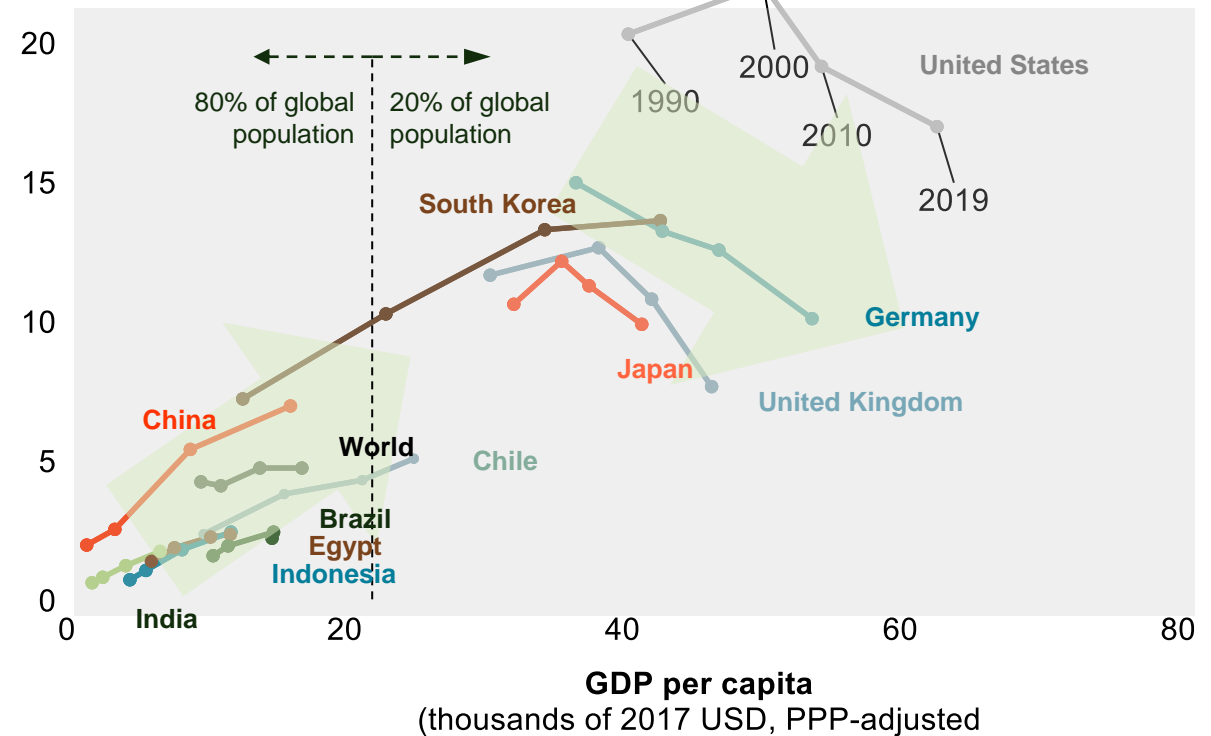

Note: * CO₂ emissions are consumption based (i.e., adjusted for trade) and do not include non-CO₂ emissions like methane
 Source: Our World in Data; World Bank; Global Carbon Project; BP Statistical Review of World Energy, 2021

4

If We Do Not Change How We Deliver or Consume Energy, GHG Emissions, and Likely Temperature, will Continue Rising

Global annual greenhouse gas (GHG) emissions

(measured in gigatons of CO₂-equivalent)

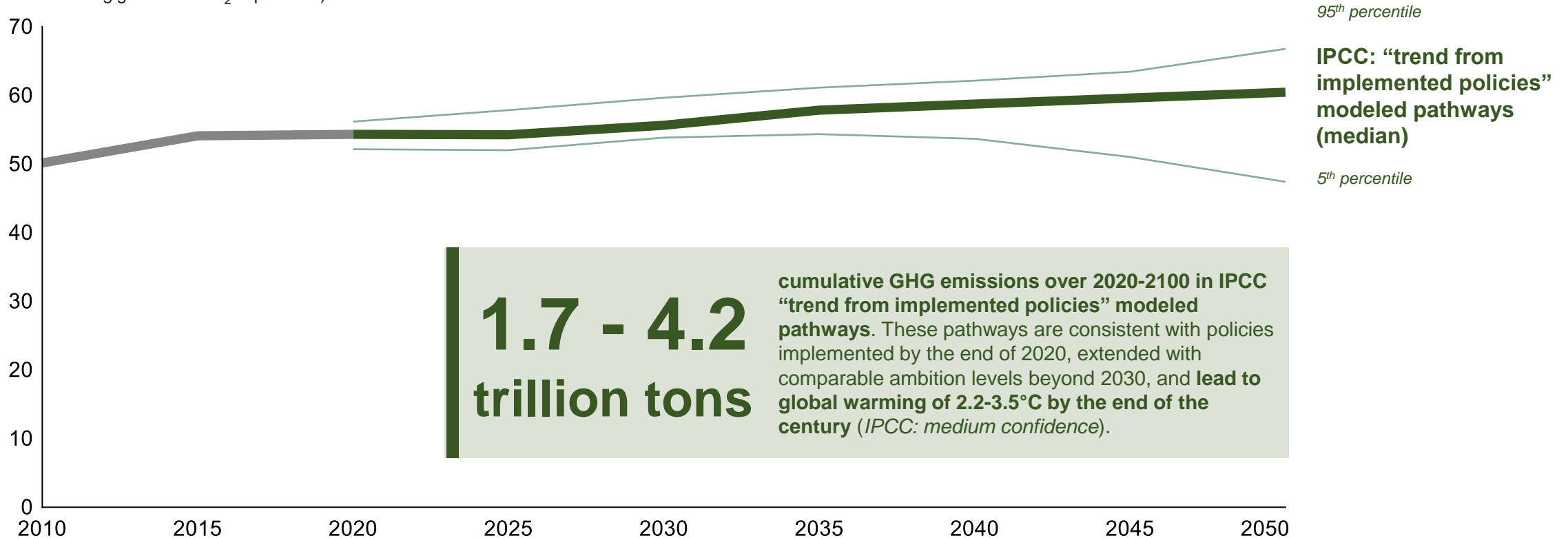

Note: Warming projections are relative to pre-industrial period and reflect warming by 2100 | Source: Our World in Data; IPCC, Sixth Assessment Report (AR6), Climate Change 2022: Impacts, Adaptation and Vulnerability, Summary for Policymakers, Figure SPM.4, Table SPM.1, Paragraph C.1.3 (2022)

Reality Check: Where We Are Today



Energy demand tripled over the last 50 years, driven by population and GDP growth



Our dependence on fossil fuels remains high and has not materially changed over the last decades



CO₂ emissions accompanied energy growth, and we have yet to “bend the curve” on global emissions



There is still considerable economic and energy inequality around the world



The world will need significantly more energy in the future to support developing economies



To mitigate the risk of climate change, GHG emissions must decline significantly, and ideally reach net zero, within a few decades

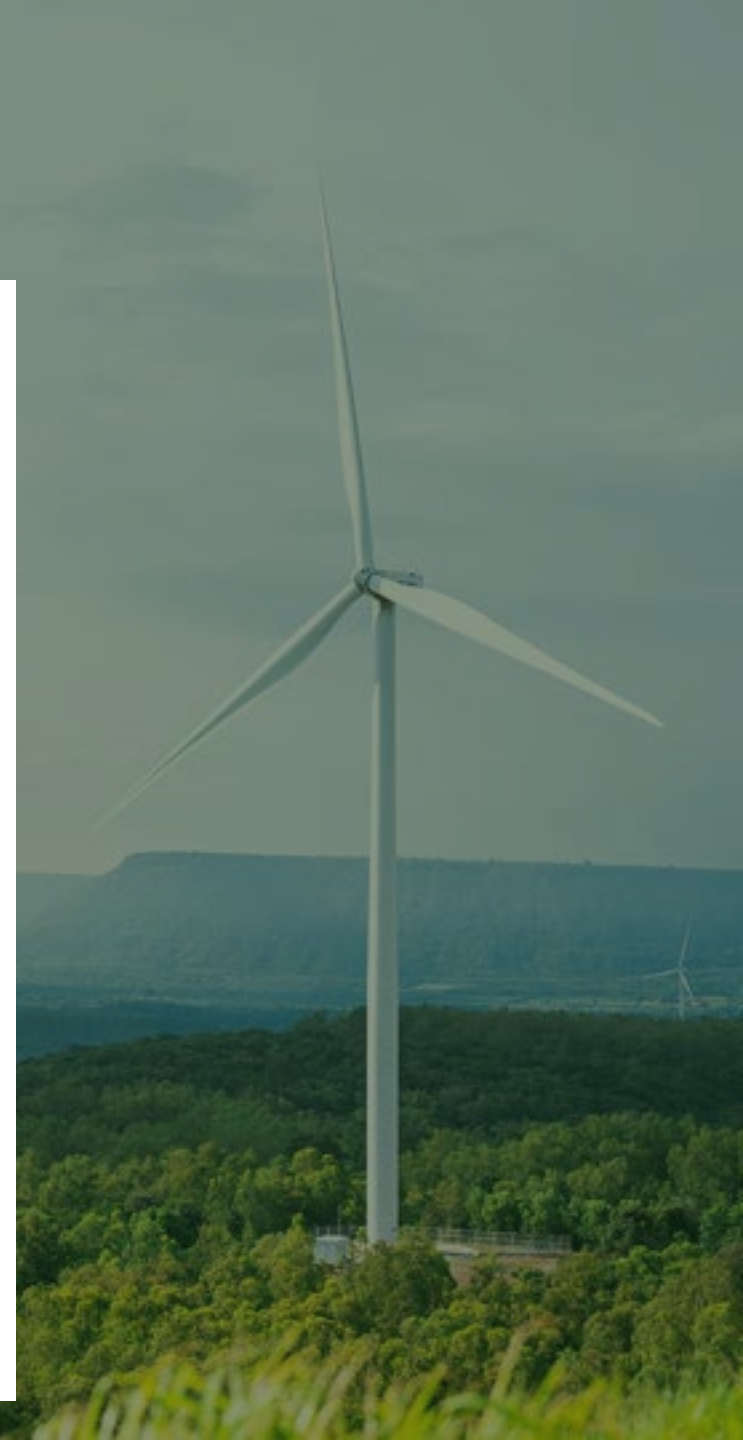

Agenda

An aerial photograph of a wind turbine in a lush green field. The turbine is white with three blades, one of which is light blue. The field is divided into sections by thin lines, and there are some trees on the left side. The overall scene is bright and clear.

01

OpenMinds
and the Dual
Challenge:
Executive
Summary

02

Energy: Uses,
Sources, and
Outlook

03

Climate
Change:
Fundamentals
and Possible
Trajectories

04

Reality Check:
Where We Are
Today

05

**The Dual
Challenge:
Headwinds
and Tailwinds**

The Dual Challenge: Headwinds and Tailwinds

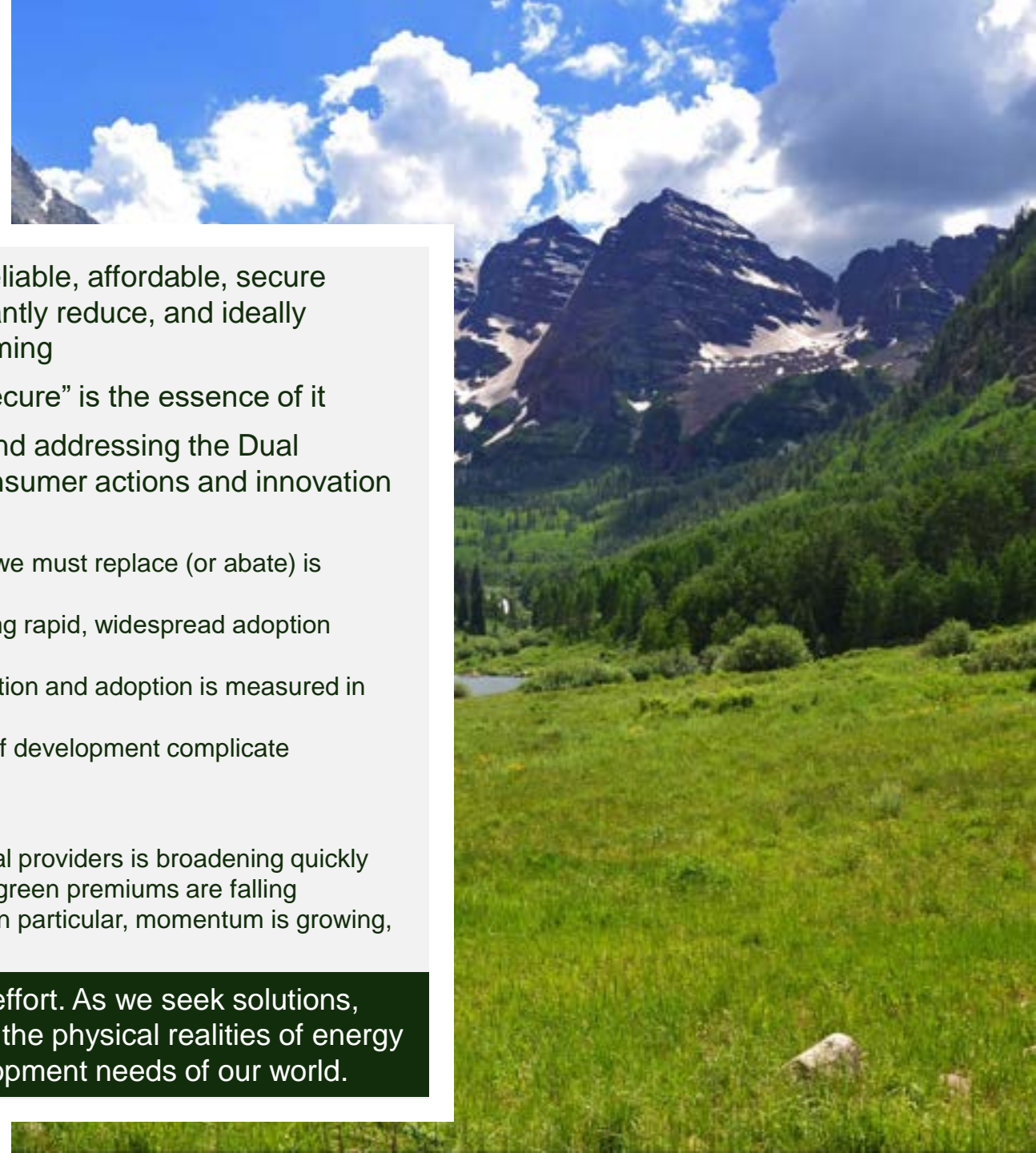

- The Dual Challenge: we must (1) deliver an increasing amount of reliable, affordable, secure energy to enable improvement in human wellbeing, and (2) significantly reduce, and ideally eliminate, emissions to mitigate environmental risks caused by warming
- Achieving “clean” without compromising “reliable, affordable, and secure” is the essence of it
- The momentum case based on current trends will not be enough, and addressing the Dual Challenge will require a mix of policy, technology, corporate and consumer actions and innovation
- But we face considerable obstacles in all these areas
 - Our dependence on fossil fuels runs deep, and the scale, and cost, of what we must replace (or abate) is enormous
 - Many currently available clean solutions come with “green premiums”, making rapid, widespread adoption financially challenging
 - Technological step-changes are needed, and the pace of technology maturation and adoption is measured in decades
 - Global cooperation is required, but competing priorities and different levels of development complicate coordination
- However, there are signs of progress—and clear tailwinds
 - Commitment to solve the problem among companies, employees, and capital providers is broadening quickly
 - Certain technologies, notably wind and solar, are scaling rapidly; for others, green premiums are falling
 - The governments of major emitters have made net zero pledges; in the US in particular, momentum is growing, as evidenced by the Inflation Reduction Act

Solving the Dual Challenge will be difficult, and it will require a global effort. As we seek solutions, we need visionary, pragmatic, system-oriented thinking that considers the physical realities of energy and climate alongside national priorities, and the economic and development needs of our world.

5

OpenMind's Objective Is Making Progress Toward Solving the Dual Challenge by 203X



Deliver energy globally...



We need to deliver affordable, reliable, secure energy for the entire world before 203X.

...while significantly reducing emissions...

We need to dramatically reduce emissions to mitigate the worst risks of climate change.

...to maximize human flourishing

The aim is to enhance the wellbeing of humans everywhere.

Achieving This Will Require Different Measures for Developed vs. Developing Countries

GHG emissions per capita

(TONS OF CO₂-EQUIVALENT)

25 tons

For developing countries, deliver **more** energy that is affordable, reliable, secure *and* clean

For developed countries, deliver **continued** energy, but at a significantly lower GHG intensity

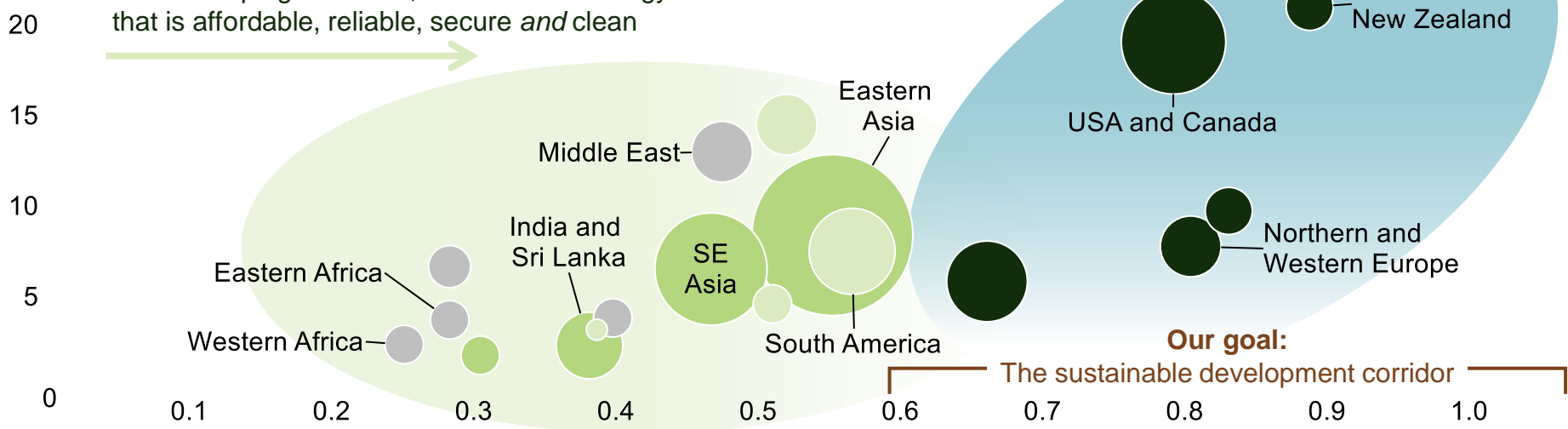

- Developed countries
- Eastern Europe and West Central Asia
- Asia and Developing Pacific
- Latin America and Caribbean
- Africa and Middle East

Human Development Index

HDI is a summary measure of key dimensions of human development: a long and healthy life, a good education, and having a decent standard of living

Note: Size of bubble represents population
Source: Our World in Data; IPCC, Sixth Assessment Report (AR6), Mitigation of Climate Change (2022)

Overall, We Must Reduce Greenhouse Gas Emissions Significantly to Limit the Impact of Warming

Global greenhouse gas emissions

Billions of tons of CO₂eq

53

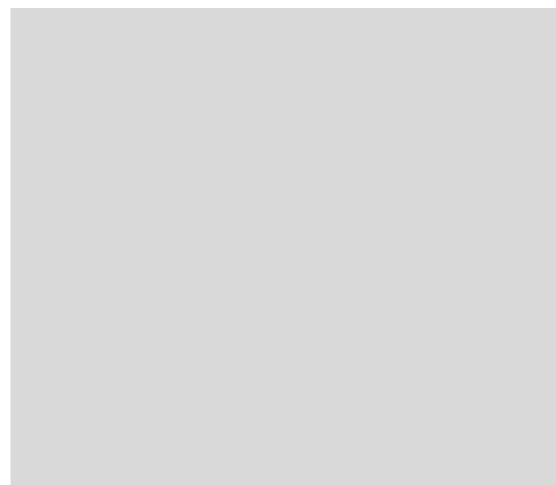

Current annual emissions

Current

-44%

Approximate change in GHG emissions, 2050 vs. 2019, in a scenario in which all announced national pledges & targets are met, according to the Climate Action Tracker (Nov 2021), not enough to limit warming to 2°C or less



60-70%

21

80-90%

9



Limit warming to 1.5°C



Limit warming to 2°C

2050: IPCC Scenarios (AR6)

Note: ">50%" and ">67%" refer to probability of reaching scenario should emissions reduction targets be reached | Source: Our World in Data; IPCC, Sixth Assessment Report (AR6), Climate Change 2022: Mitigation of Climate Change – Summary for Policymakers, Table SPM.1 (2022); Climate Action Tracker (updated Nov 2021)

Emissions Cuts Will Need to Happen in Parallel With Rising Energy Demand Driven by Demographics and Development

Global population

BILLIONS

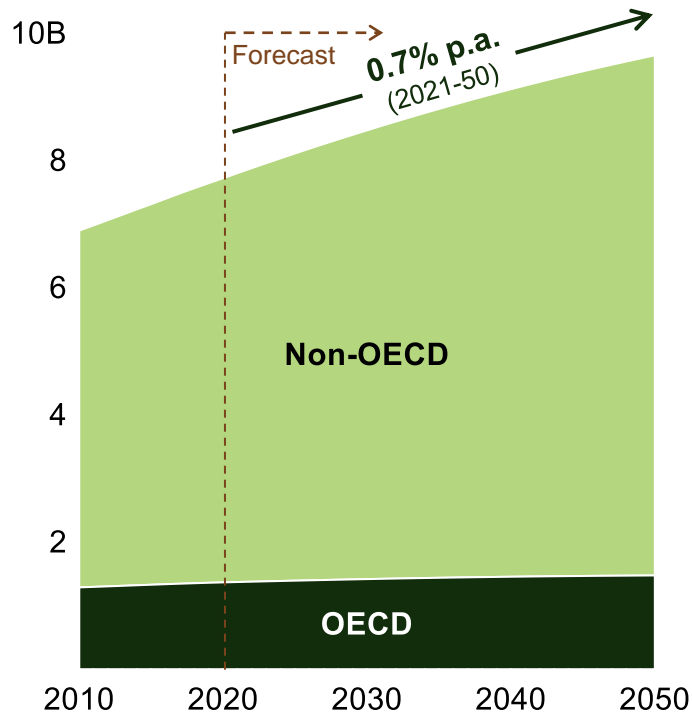

Global GDP

PPP, TRILLIONS OF 2015 USD

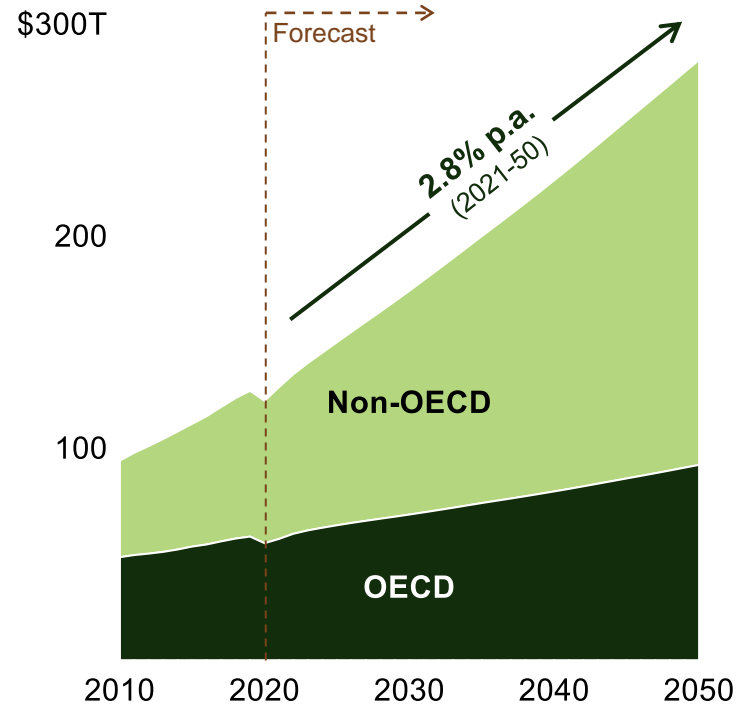

Global energy consumption

PETAWATT-HOURS

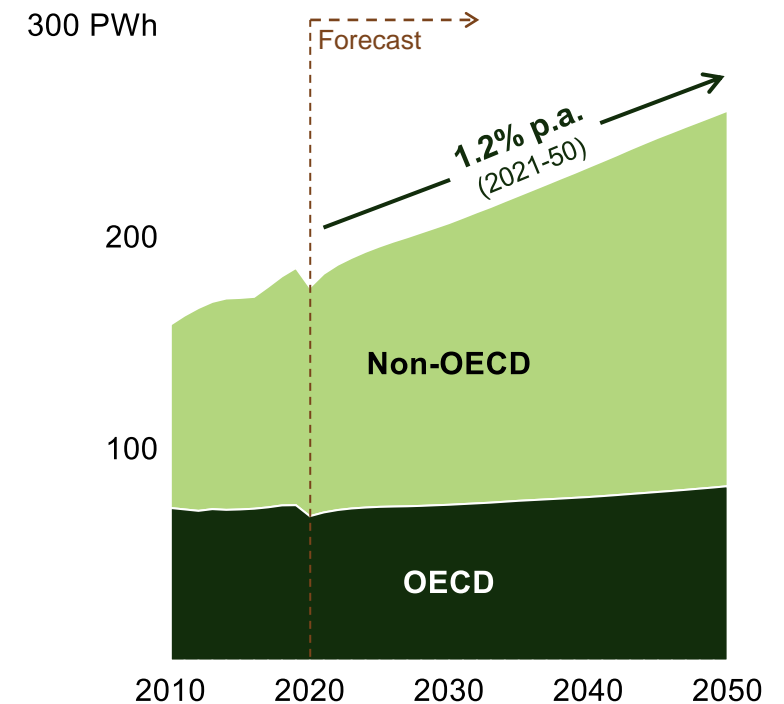

Source: Our World in Data; U.S. Energy Information Administration, International Energy Outlook 2021 (IEO2021), reference case

Achieving Net Zero Emissions by 2050 Amidst Demographic and Economic Growth Would Require Unprecedented Change

Global CO₂e emissions¹
(gigatons of CO₂e)

Demographic and economic backdrop
for 2022-2050 period

1.7B projected population growth²

>2X projected real GDP growth,
or 2.6% p.a.³

60

40

20

0

50

100

150

200

250

1970

1980

1990

2000

2010

2022

GLOBAL PRIMARY ENERGY DEMAND

(petawatt-hours)

Note: (1) CO₂e emissions include land use change; (2) UN median fertility scenario; (3) GDP expressed in 2022 USD in purchasing power parity terms via IEA and UN
Source: IEA World Energy Outlook 2023; Our World in Data; UN Trade and Development

But the Experience of Some Advanced Economies Suggests We *Can* Decouple Economic and Emissions Growth

Change in GDP, CO₂ emissions, and population, 1990-2021 for select countries

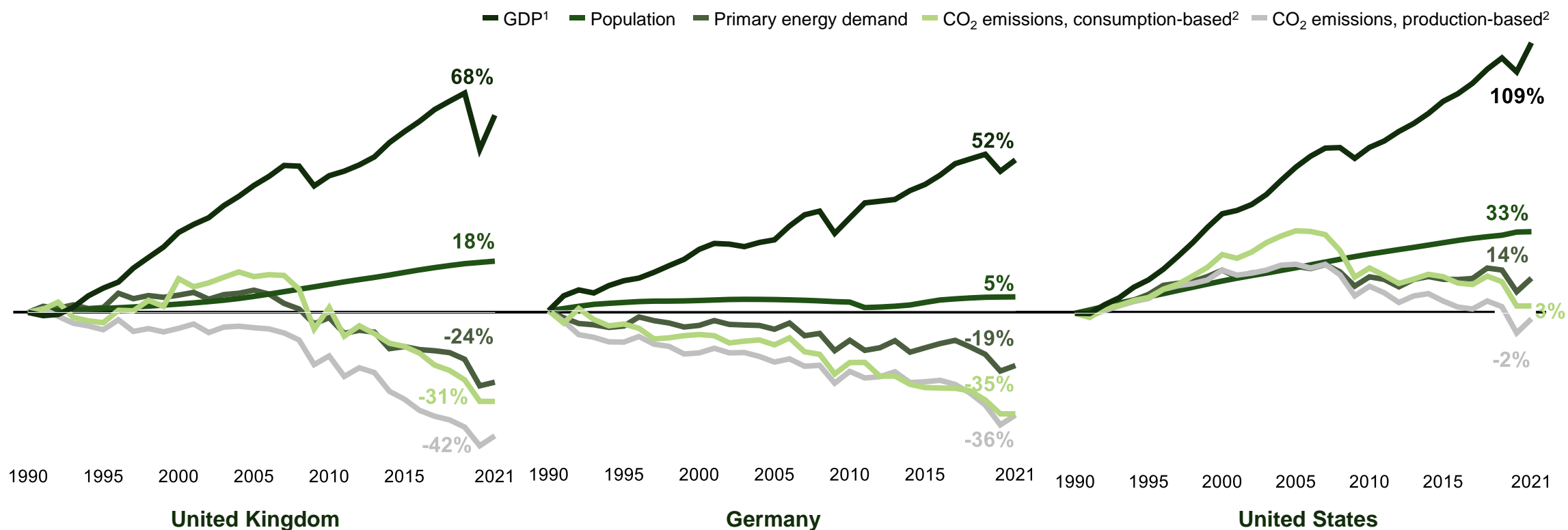

Note: (1) GDP is measured in real 2015 US dollars; (2) consumption-based emissions are adjusted for trade (i.e., production emissions minus emissions embedded in exports plus emissions embedded in imports), and neither consumption-based nor production-based include emissions from land use change

Source: Our World in Data; World Bank; Global Carbon Project; BP Statistical Review of World Energy, 2021

To Realize Our Aim, We Will Need Action in 3 Areas



Markets

Financial structures, corporate / institutional investment postures, and consumer preferences that favor low- or zero-emissions solutions



Technology

Scientific breakthroughs across a range of low-carbon solutions



Policy

Smart rules and regulations that encourage the development and adoption of low- or zero-emissions tech

5

But We Face Challenges in All 3



Technology

Decarbonization will require some new and un-scaled technologies...

...And new technologies will present new complications

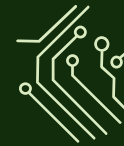

Markets

Fossil fuels are deeply embedded in modern civilization...

...And “Green Premiums” remain high



Policy

Global consensus and coordination are necessary...

...But countries at different stages of development have competing priorities



5

Fossil Fuels Are Deeply Embedded in Modern Civilization, With a Production and Distribution System Built Over 150 Years



5



Markets

The Material “Pillars” of Civilization Depend Heavily on Fossil Fuels and Are Significant Emissions Sources

Materials	 Cement	 Steel	 Plastic	 Ammonia
Product volume in metric tons	4.3 billion tons	1.9 billion tons	400 million tons	180 million tons
Emissions CO₂e in metric tons	3.9 billion tons	3.4 billion tons	520 million tons	500 million tons
Civilizational significance	Central ingredient in concrete, the material upon which modern infrastructure, including cities, bridges, roads, dams, hospitals, and runways, is built	Most widely used metal, valued for its abundance and physical properties. Found in everything from cooking equipment and cars, to bridges and buildings, to wind turbines and pipelines	Lightweight, durable, and easily moldable. Plastics are ubiquitous, and are particularly important in healthcare	Crucial ingredient in fertilizer. Without it, we could not feed nearly half the world
Fossil fuel dependence	Heating in cement production depends on fossil fuels (e.g., coal dust, heavy fuel oil)	About two-thirds of the world's steel production depends on coal for purifying iron and heating	Crude oil and natural gas are used as feedstocks in the vast majority of plastics production	Natural gas (methane) is critical to synthesis, both as a feedstock and as the source of energy needed to provide high temperature and pressure

Source: Vaclav Smil, How the World Really Works; Columbia Climate School; Institute for Industrial Productivity; EIA

Achieving Net Zero by 2050 Would Require an Unprecedented Ramp-up in the Deployment of Clean Solutions...

Annual global wind and solar PV capacity additions

GW OF CAPACITY

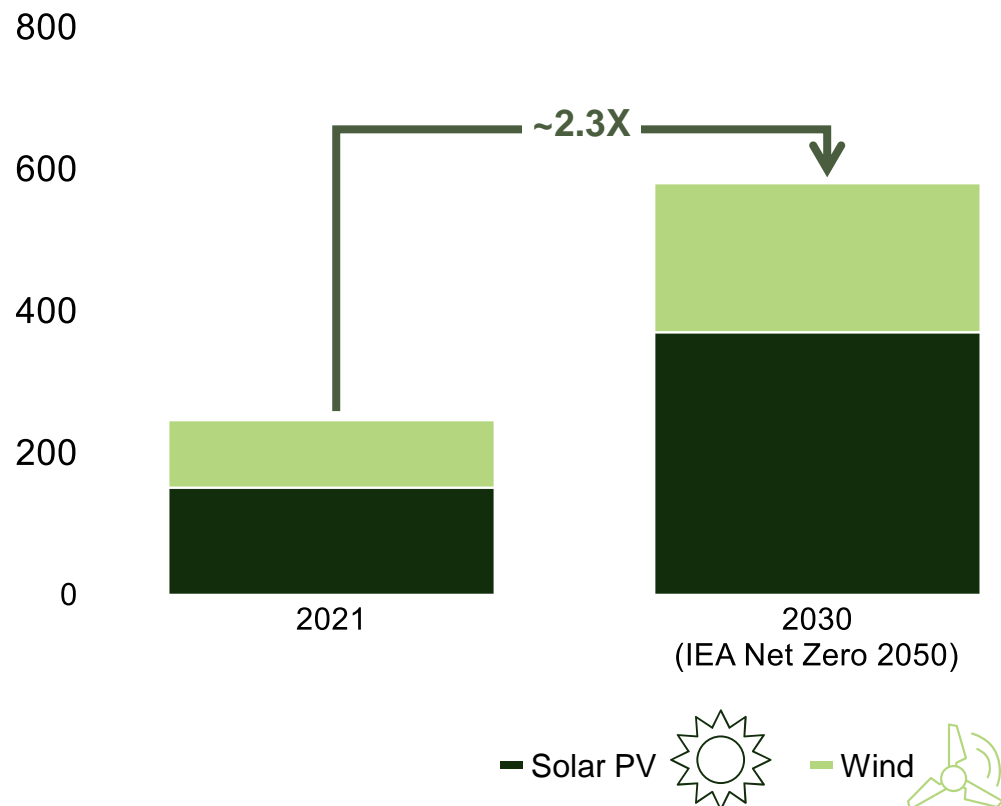

Annual global electric vehicle sales share

PERCENTAGE OF TOTAL CAR SALES

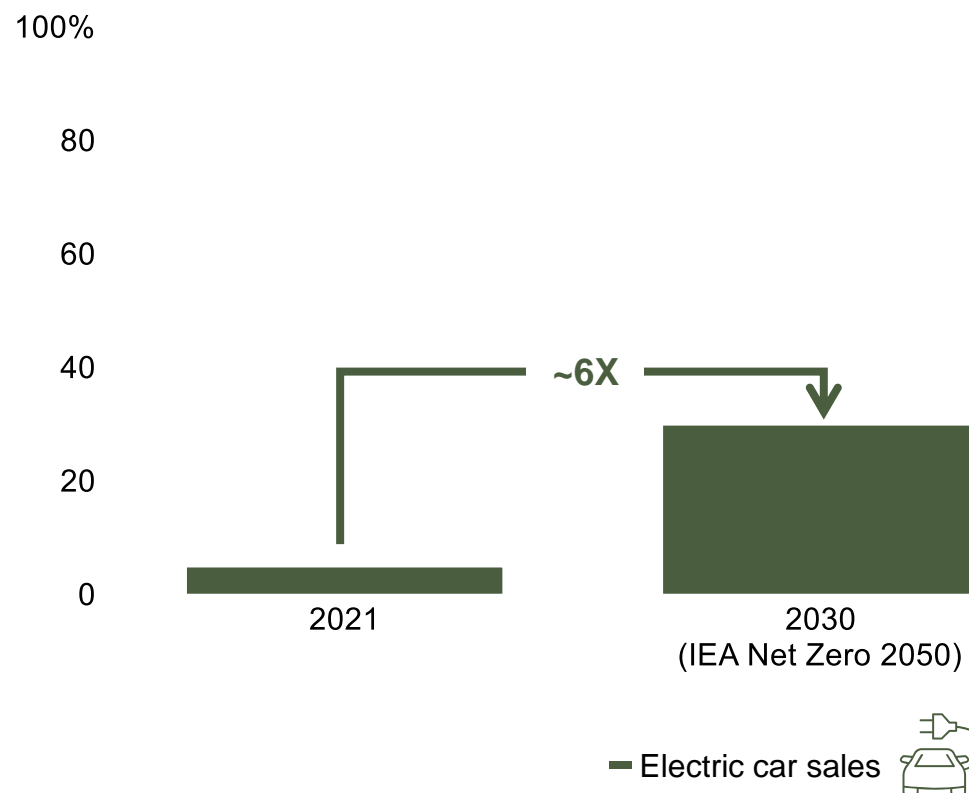

Source: IEA (2022), World Energy Outlook 2022, IEA, Paris <https://www.iea.org/reports/world-energy-outlook-2022>, License: CC BY 4.0 (report); CC BY NC SA 4.0 (Annex A)

5

...As Well as an Immense Expansion of Critical Infrastructure That Enables Those Solutions

Global number of public charging points for EVs

MILLIONS OF PUBLIC CHARGING POINTS

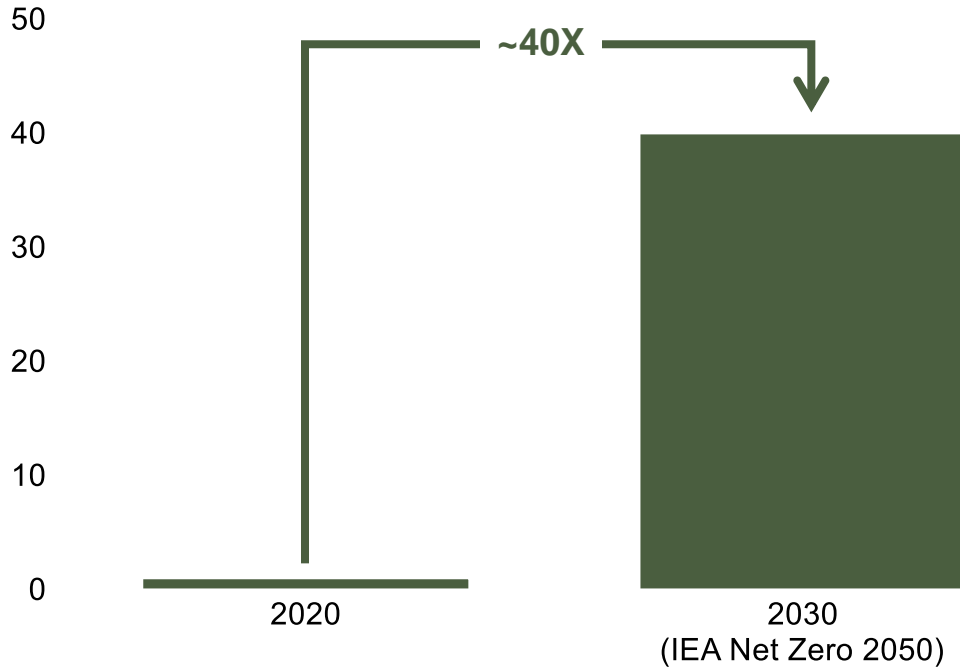

Public EV charging point



Annual global battery production for EVs

GWH OF PRODUCTION

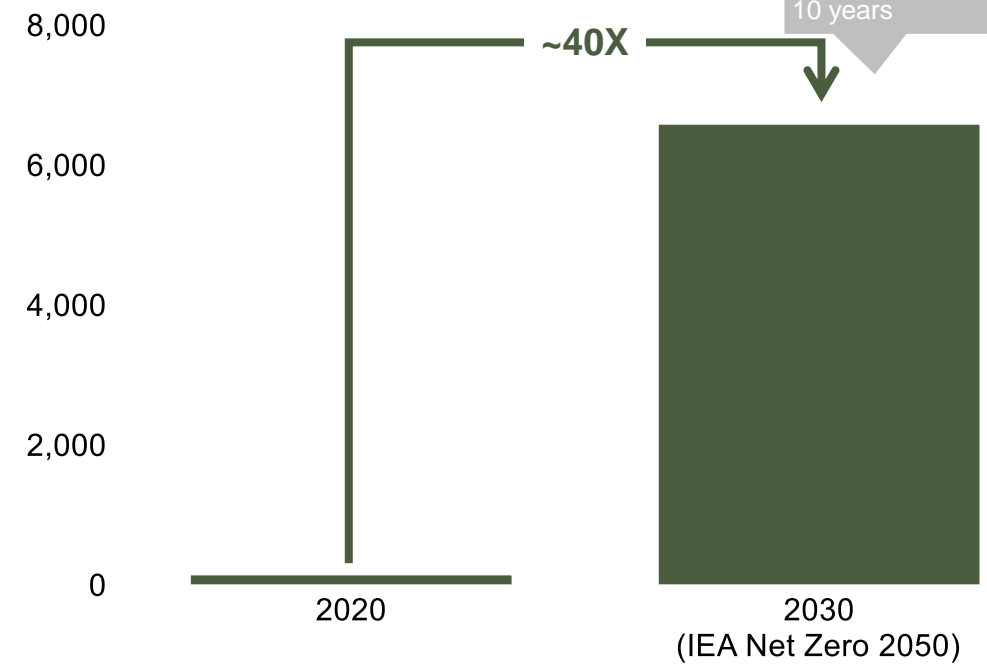

Annual EV battery production



Equivalent to adding ~20 "gigafactories" each year for the next 10 years



5



Markets

Continued Progress Requires a Significant Industrial Effort

Our energy system will move from “fuel intensive” to “mineral intensive”

Critical mineral intensity (kg per vehicle)

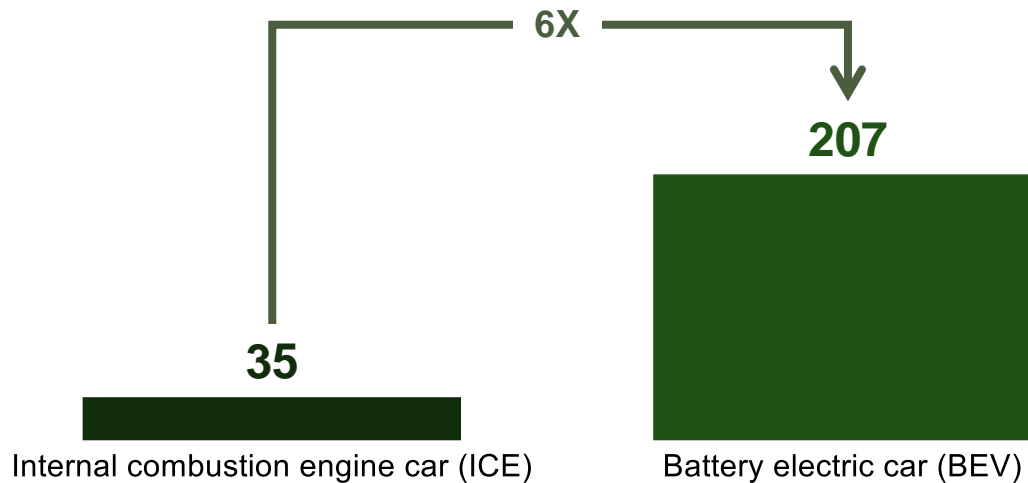

Critical material requirement shifts



In the US, we will need to expand transmission capacity rapidly, more than double the historical pace

US high-voltage transmission capacity growth per annum, 2020-2030

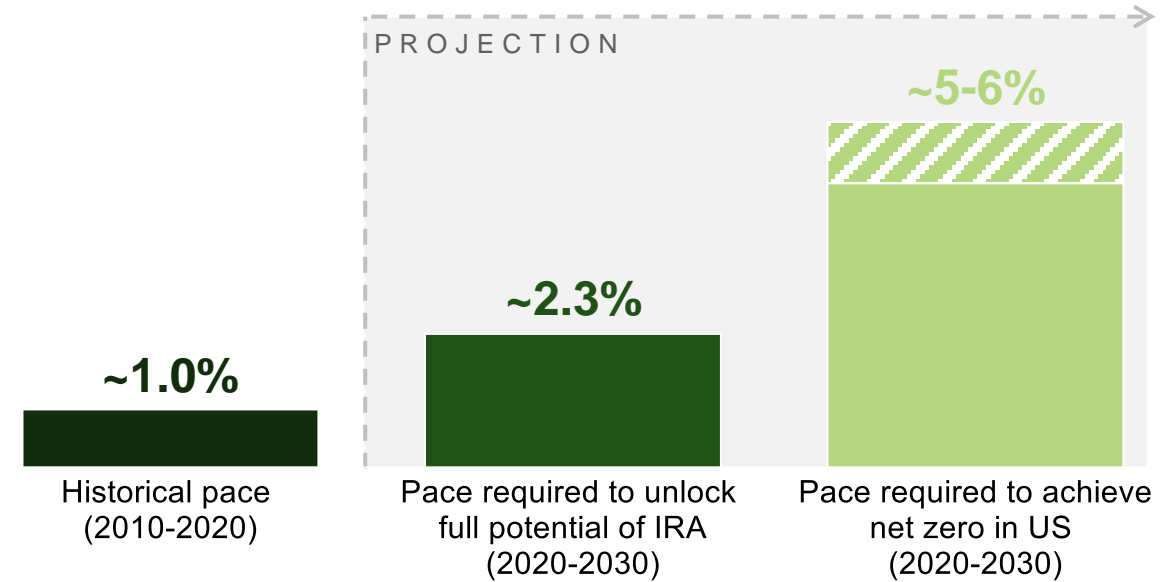

Pace of construction increases



Note: Critical minerals include copper, platinum, rare earths, graphite, cobalt, manganese, nickel, lithium, and others. Transmission capacity growth measured using GW-miles.
 Source: IEA, Energy Technology Perspectives 2023, Figure 1.9; Princeton, Net Zero America; Princeton, Electricity Transmission is Key to Unlock the Full Potential of the Inflation Reduction Act

The Attendant Ramp-Up in Mineral Extraction Would be Enormous

Annual global production of select minerals

THOUSANDS OF METRIC TONS PER YEAR
2030 forecasts are shown based on IEA NZE scenarios

Copper

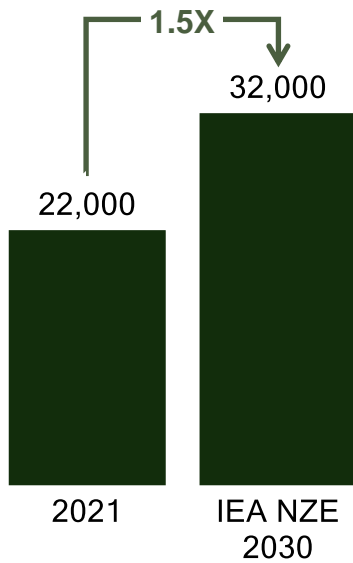

Nickel

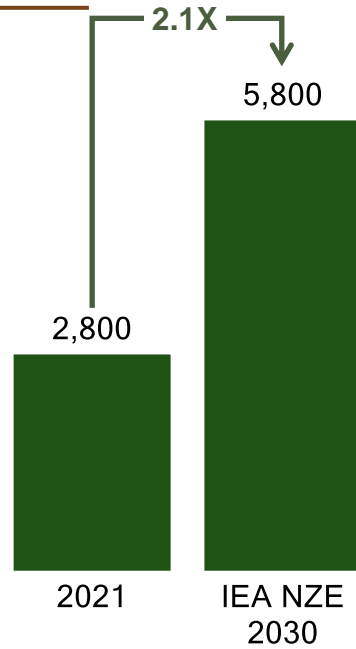

Lithium

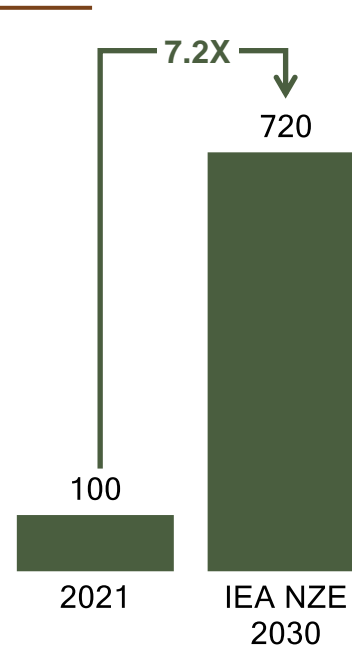

Cobalt

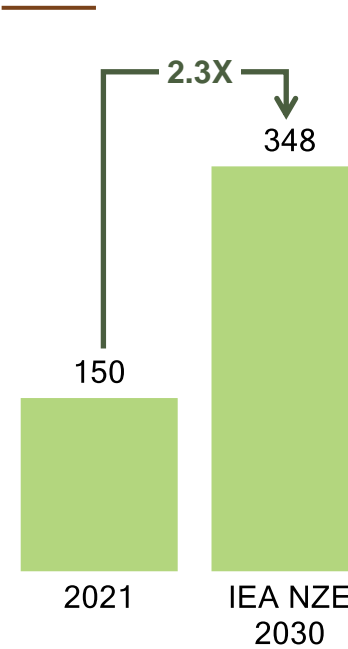

For Example, Almost 200 New Mines Would Be Required to Support Critical Mineral Demand by 2030



We are underinvesting in mines relative to what is required to achieve 2030 climate goals

Funding required to meet mineral demand over 2022-2030 in IEA NZE (billions of USD)

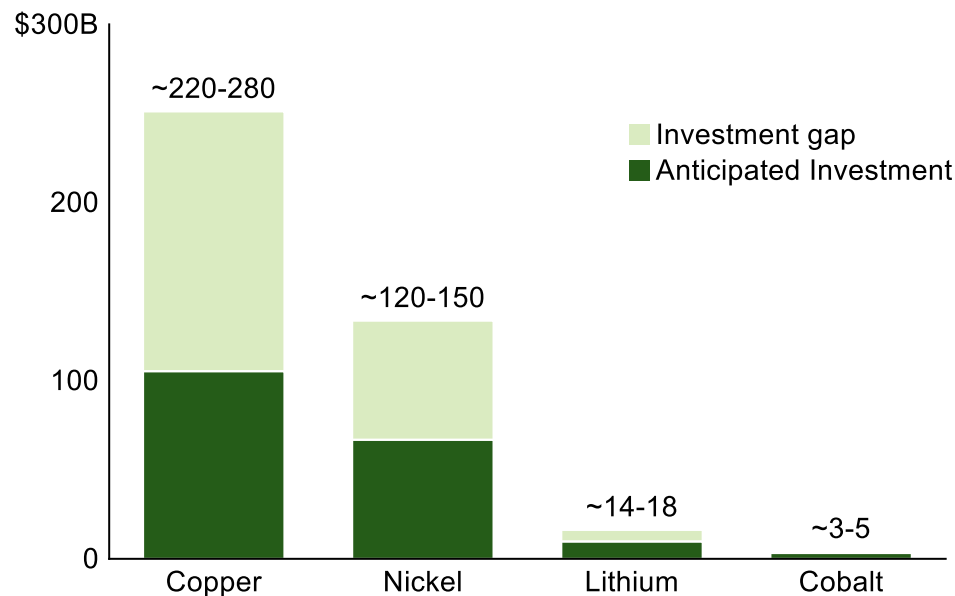

- To achieve 2030 climate goals under the IEA NZE scenario, **we need ~180 new mines:**
 - ~30 Cobalt mines
 - ~70 lithium and nickel mines
 - ~80 copper mines (~250 copper mines exist today)
- ~\$360-450B investment required**, and there is a projected **investment gap of ~\$200-250B**

17
years

Average amount of time to open a new mine, this includes exploration, feasibility, development and construction (*excludes ramp-up time*)

Note: IEA NZE = IEA Net Zero Emissions scenario
Source: IEA (2023), Energy Technology Perspective 2023, Figure 3.8, License: CC BY 4.0

As We Consider Decarbonizing Electricity Generation, Land Use Could Be a Major Constraint

Land use per unit of produced electricity

SQUARE METERS PER MEGAWATT-HOUR; MEDIAN VALUE

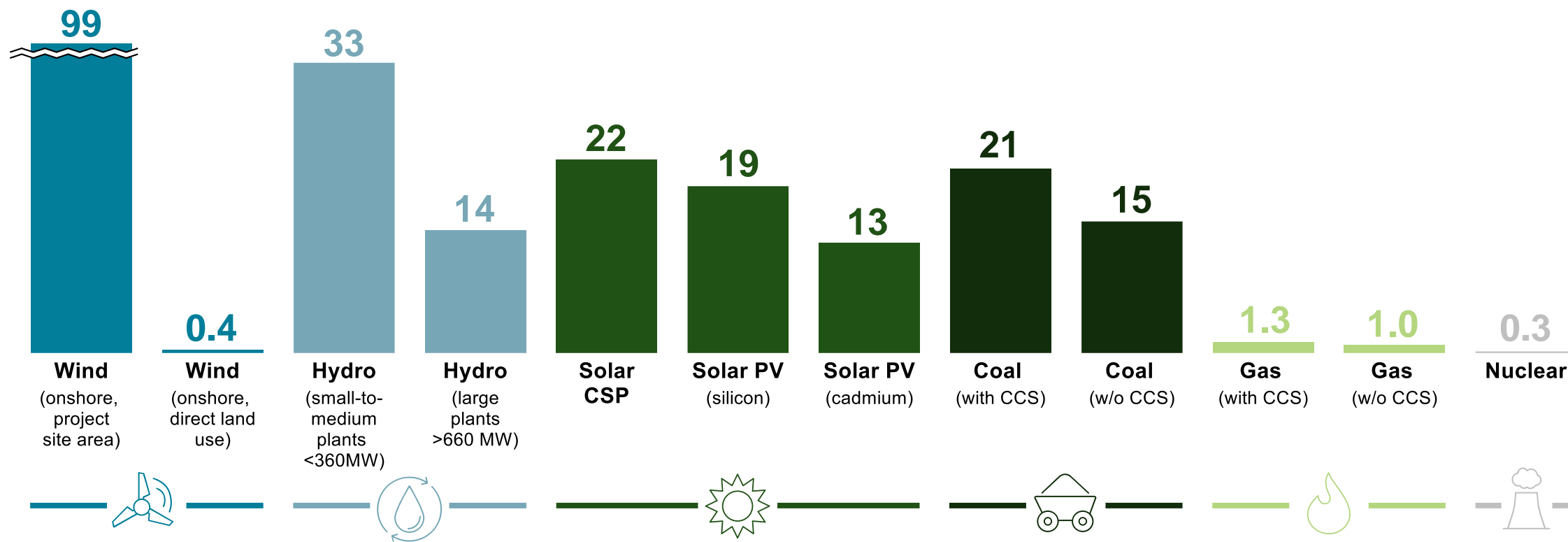

Note: Land use includes both direct use of land by the facility and indirect use of land for the mining of materials used in construction, fuel inputs, decommissioning, and waste management; CCS = Carbon Capture and Storage.
Source: Our World in Data; UNECE, Integrated Life-cycle Assessment of Electricity Sources (2021); Lovering et al., Land-use intensity of electricity production and tomorrow's energy landscape (2022)

5

In the US, Full Decarbonization by 2050 Would Require Massive Shifts in Energy Infrastructure

Fully decarbonizing the US by 2050, absent major technological breakthroughs, would entail...

Dramatically expanding the supply of wind and solar to achieve 100% renewable electricity

13X
more solar & wind

Capacity of wind (10X) and solar (20X) must expand significantly. Pace of deployment would be 2-3X that of the one-year US record over the next two decades, and it would approach the one-year world record by 2050

590,000
sq. km of land

Total area spanned by onshore wind and solar farms, an area roughly equal to the combined size of IL, IN, OH, KY, TN, MA, CT, and RI

3X
more high voltage
transmission capacity

Electricity transmission expands to about 700K GW-km, a 200%+ increase from 2020

Building an enormous carbon capture and sequestration system

1-1.7 billion
tons of CO₂
sequestered per year
by 2050

A massive carbon capture and storage (CCS) system is required to capture emissions from hard-to-abate sources like cement production and natural gas reforming

1.3-2.4X
size of CCS system
relative to current US
crude oil production

On a volume basis, the system would handle 1.3-2.4X the volume of current US crude oil production and would necessitate ~110,000 km of new CO₂ pipeline infrastructure

Note: Figures shown are for NZA's E+ "High Electrification" scenario
Source: Princeton University, Net Zero America; Vaclav Smil, How the World Really Works

5

2050 Would Require the World to More Than Triple Its Investment in Clean Energy

Annual global energy investment needs from 2023-2030 in different IEA scenarios

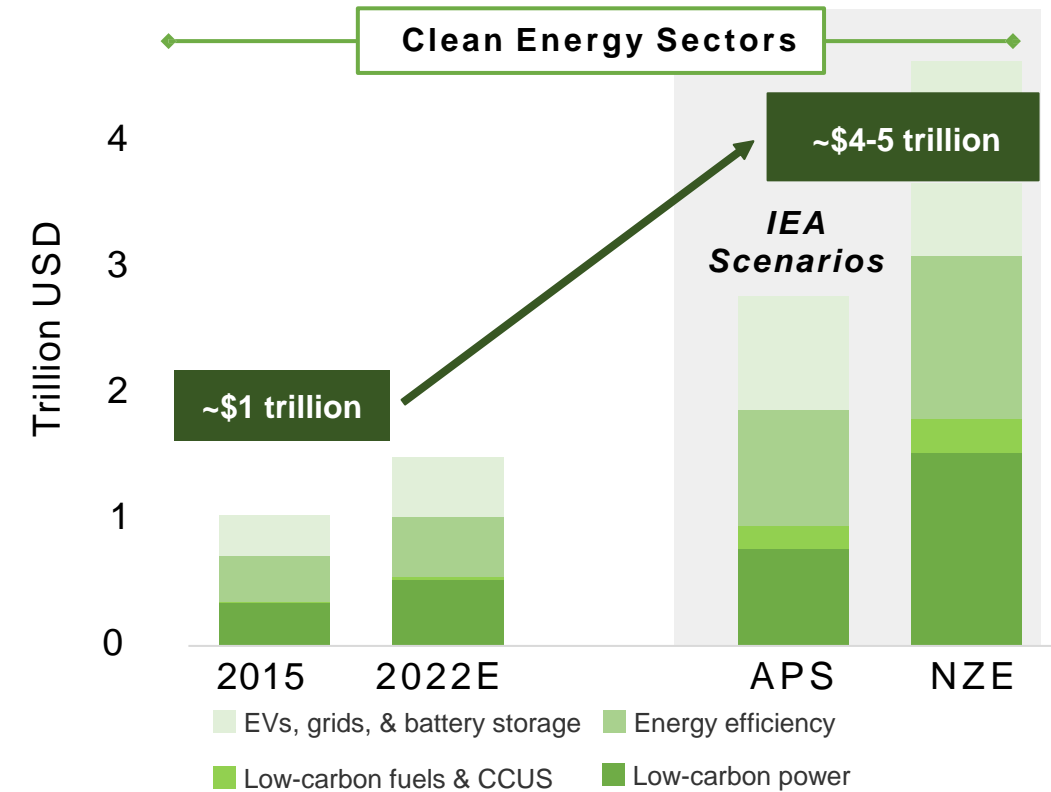
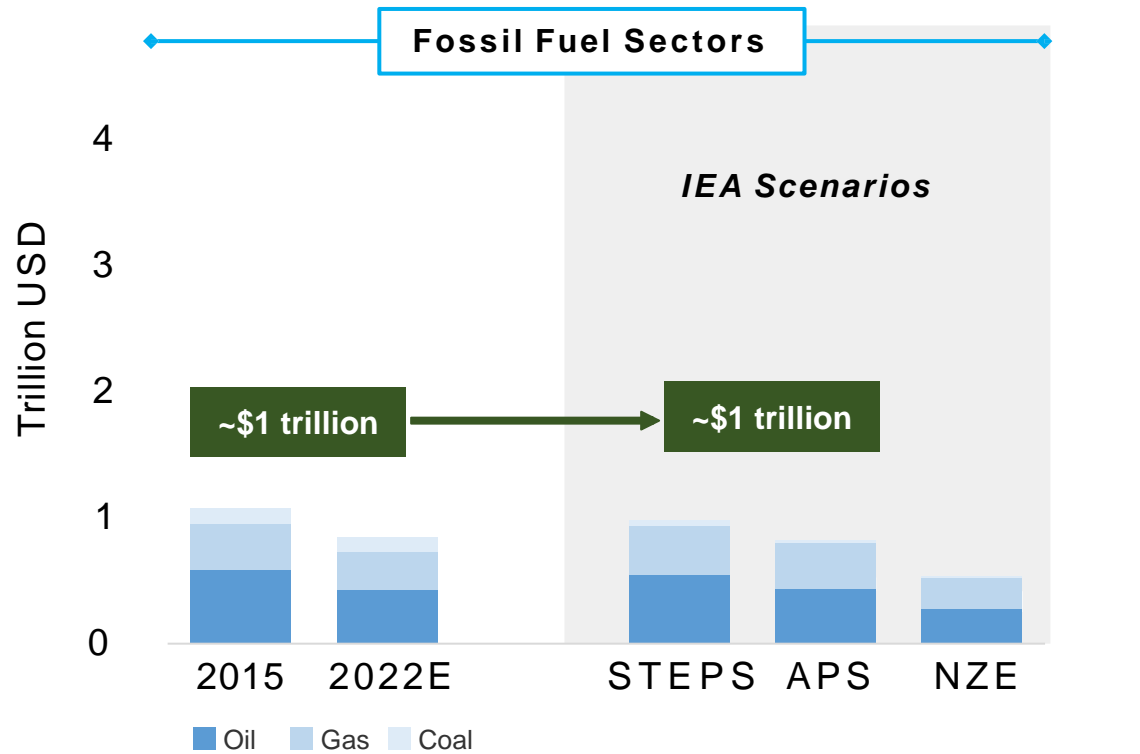

Note: STEPS = Stated Policy Scenario; APS = Announced Pledges Scenario, the spending required to meet all country and regional climate pledges on time and in full. NZE = Net Zero Emissions by 2050 Scenario, the spending required to get the global energy sector to net zero by mid-century.

Source: IEA (2023), World Energy Investment 2023, IEA, Paris <https://www.iea.org/reports/world-energy-investment-2023>, License: CC BY 4.0

Today, “Green Premiums” Hamper the Adoption of Low- or Zero-Emissions Solutions

Incremental price of zero / low carbon substitute

PERCENTAGE ABOVE EXISTING SOLUTION COST

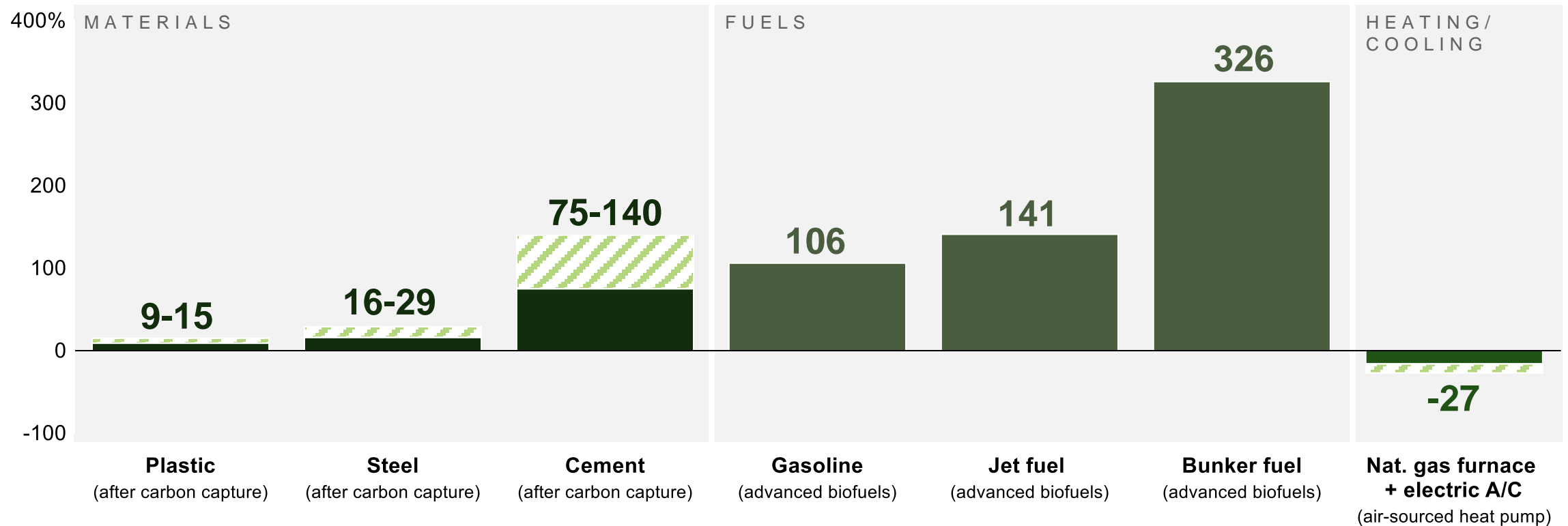

Source: Bill Gates, How to Avoid a Climate Disaster (2021)

5

Despite These Challenges, Sustainability is Becoming More Important for Companies, Investors, and Employees

Companies are committing to reducing emissions

More and more companies in the US and elsewhere, ranging from Microsoft to Air France to CEMEX, are setting “science-based targets” as they work to reduce emissions

Annual verifications and commitments (2015-YTD2022)

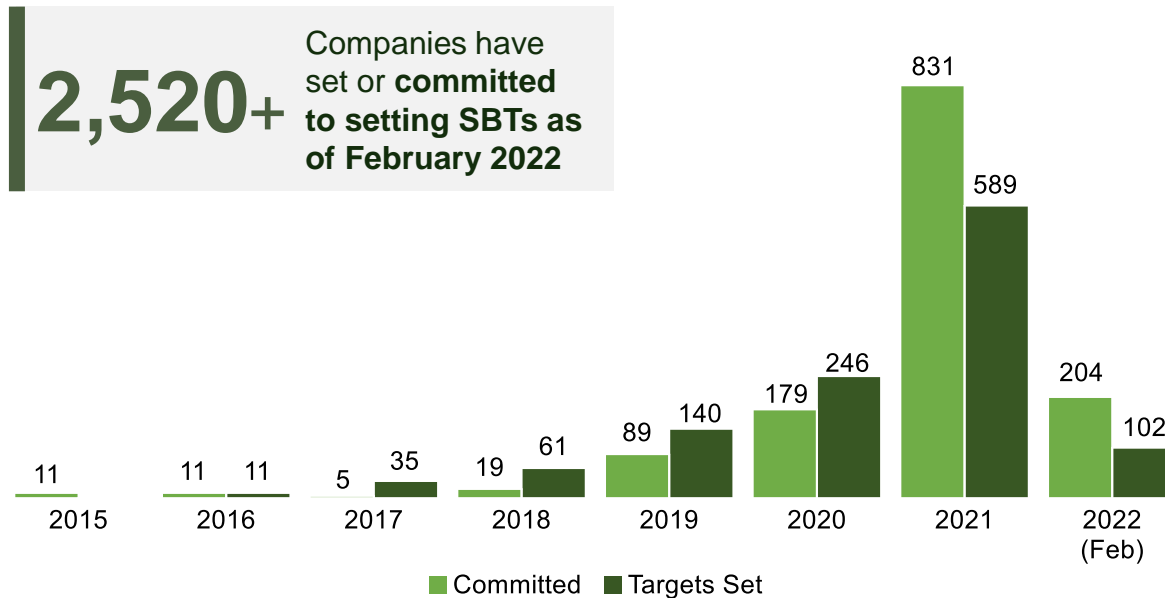

Wider stakeholders are prioritizing ESG

In private equity, limited partners (LPs) are making ESG a priority, and employees around the world believe sustainability should be a top priority for companies



Note: Companies work with the Science Based Targets initiative (SBTi) to set targets that provide a clearly defined pathway to reduce GHG emissions
 Source: Science Based Targets initiative; Refinitiv; INSEAD

5 Technologically, We Likely Need a Multitude of Breakthroughs to Deeply Decarbonize

- Zero-carbon plastics
- Zero-carbon cement
- Zero-carbon fertilizer
- Zero-carbon steel
- Carbon capture (direct air capture and point capture)
- Next-generation nuclear fission
- Nuclear fusion
- Nuclear fusion
- Pumped hydro
- Geothermal energy
- Grid-scale electricity storage that can last a full season
- Hydrogen produced without emitting carbon
- Underground electricity transmission
- Plant- and cell-based meat and dairy
- Zero-carbon alternatives to palm oil
- Drought- and flood-tolerant food crops
- Advanced biofuels
- Electrofuels
- Thermal storage
- Coolants that don't contain F-gases

...and we need them cheap enough for middle-income countries to buy



5

Technical Progress Typically Proceeds Slowly, Moore's Law an Exception

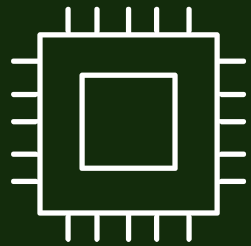

46% p.a.

Moore's Law:
rate that the number of transistors in a dense integrated circuit increases (i.e., doubling about every two years)



2% p.a.
increase in **corn yields** since 1950



1.7% p.a.
decrease in **energy intensity** to produce a **ton of steel** since 1950

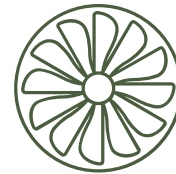

1.5-2% p.a.
increase in efficiency of converting **thermal power to electricity** during the 20th century

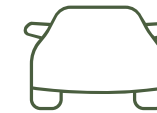

2.5% p.a.
improvement in **U.S. car gas mileage** from 1973 to 2014

vs.



2.5-3% p.a.
increase in **light efficacy** (lumens per watt), 1881-2014



5.6% p.a.
increase in **speed of intercontinental travel** from 1900 to 1958 – but then ~0% p.a. thereafter

Source: Vaclav Smil, Moore's Curse

And History Suggests the Diffusion of New Energy Technologies Takes Decades

Years until supplying 25% of global primary energy supply

(share of global primary energy supply)

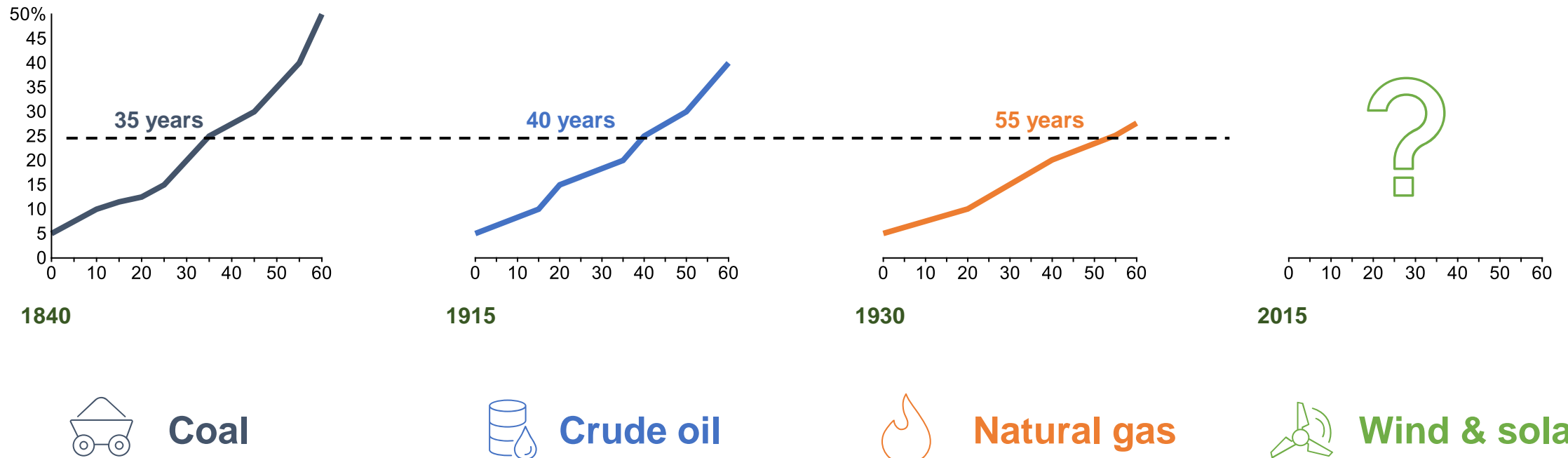

Note: Based on time from 5% to 25% of global energy supply
 Source: Vaclav Smil, *Energy Transitions: Global and National Perspectives* (2017)

However, We Have Seen Encouraging Progress in a Range of Critical Areas

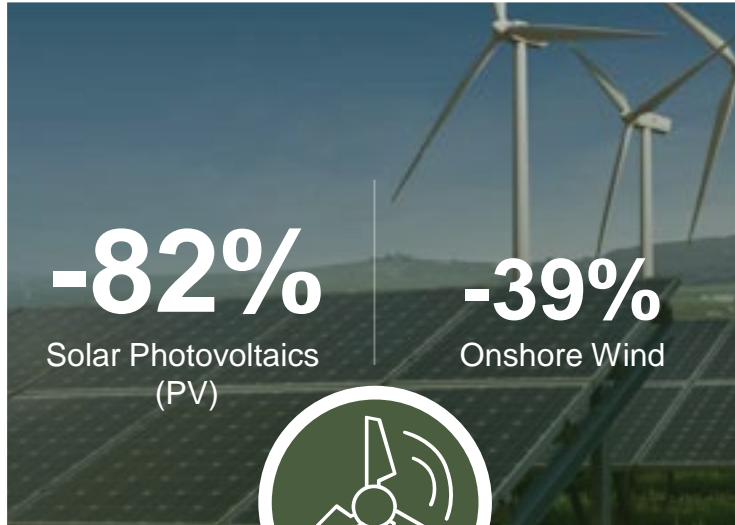

Low-cost wind and solar

Over 2010-2019, there has been an 82% and 39% reduction in the cost of utility-scale PV and onshore wind systems, respectively.



Electric vehicle price parity

In Europe, passenger car EVs are expected to reach price parity with internal combustion engine (ICE) equivalents in the 2025-2027 timeframe, and many manufacturers have committed to EV sales targets.



Direct air capture scale up

The first large-scale direct air capture plant is being developed in the US, with a planned capacity of 1M tons of CO₂ per year.

Source: NREL; IRENA; Bloomberg NEF; IEA



5

And the Shale Revolution Suggests Transitions Can Happen Quickly at the Scale of US Oil & Gas Production

Technology

The combination of horizontal drilling and hydraulic fracturing enabled the shale revolution



Annual US natural gas marketed production

TRILLION CUBIC FEET OF NATURAL GAS PER YEAR

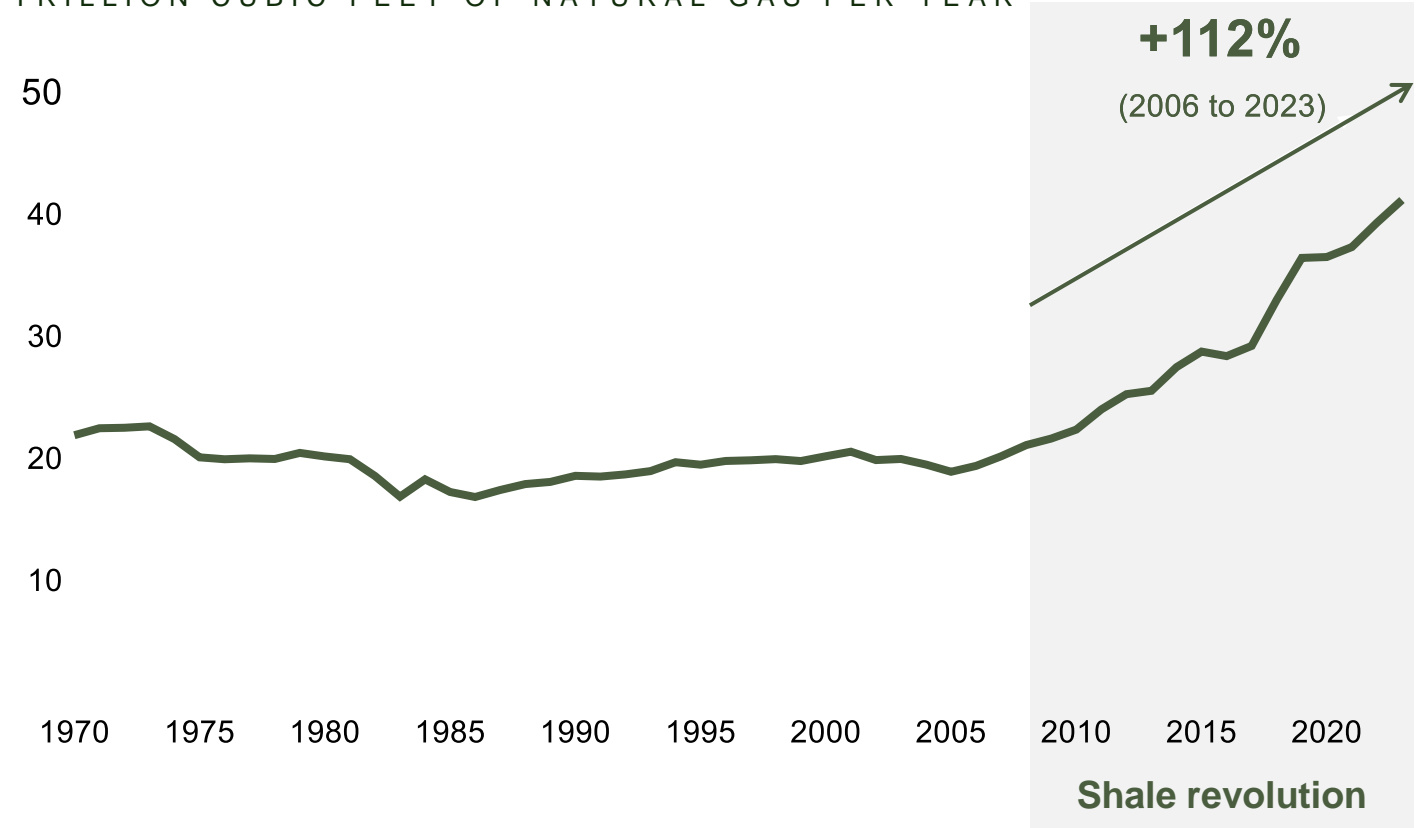

Source: EIA

5



Policy

Whether Policy- or Market-Driven, Seemingly Large Actions May Have Only Modest Impacts on Emissions

Global emissions dropped



in 2020 during the COVID pandemic, despite a major slowdown in economic activity

Removing GHG emissions from all passenger vehicles in the world would reduce emissions by



Completely eliminating beef from global diets would reduce emissions by

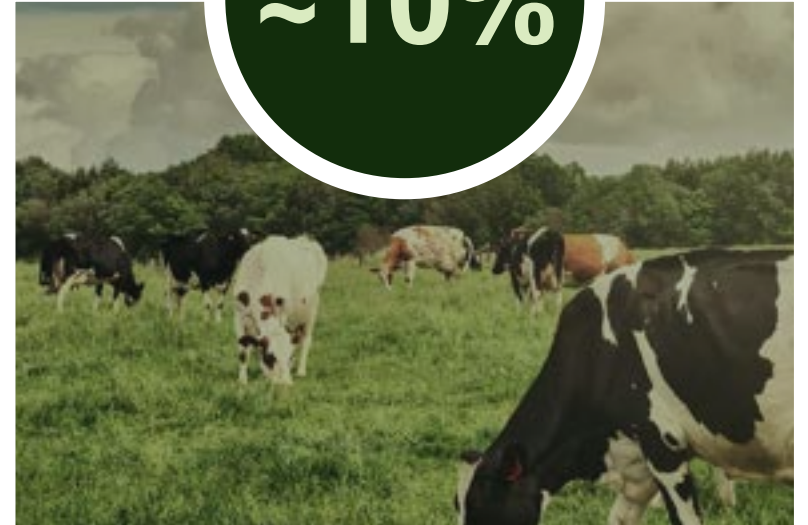

Source: Carbon Brief; IEA; ICCT (International Council on Clean Transportation); Bill Gates, How to Avoid a Climate Disaster (2021)

5



Policy

Global Cooperation is Required, but Competing Priorities and Different Levels of Development Complicate Coordination



Developing nations

need affordable and reliable energy to support economic development



Developed nations

want to reduce emissions, but vary in their ambition and willingness to invest



Nations with high climate change risk

want ambitious change, but need additional resources



Three Decades of International Climate Conferences Have Not Yet “Bent the Curve” on Global Emissions

Annual global CO₂ emissions from energy and land use change

BILLIONS OF TONS OF CO₂; EXCLUDES NON-CO₂ GHGS

65%

Rise in global CO₂ emissions since the UN Framework Convention on Climate Change was established in 1992

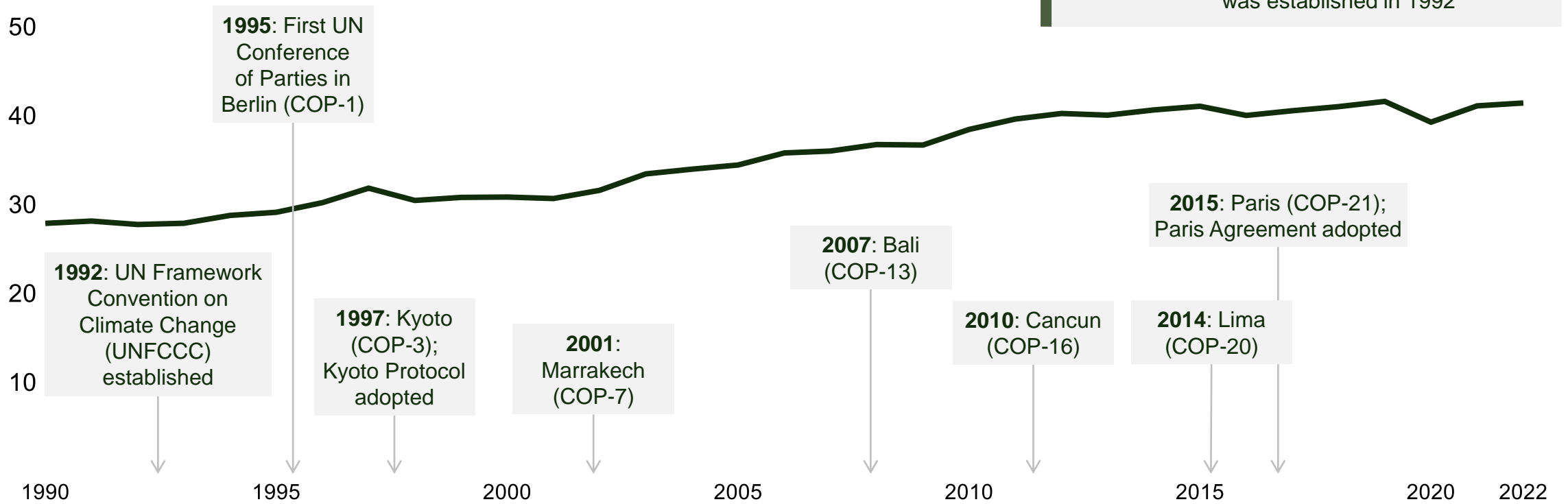

Source: Global Carbon Project; Vaclav Smil, How the World Really Works



5

And Today, Nearly All Paris Agreement Participants are Behind Agreed-Upon Aims

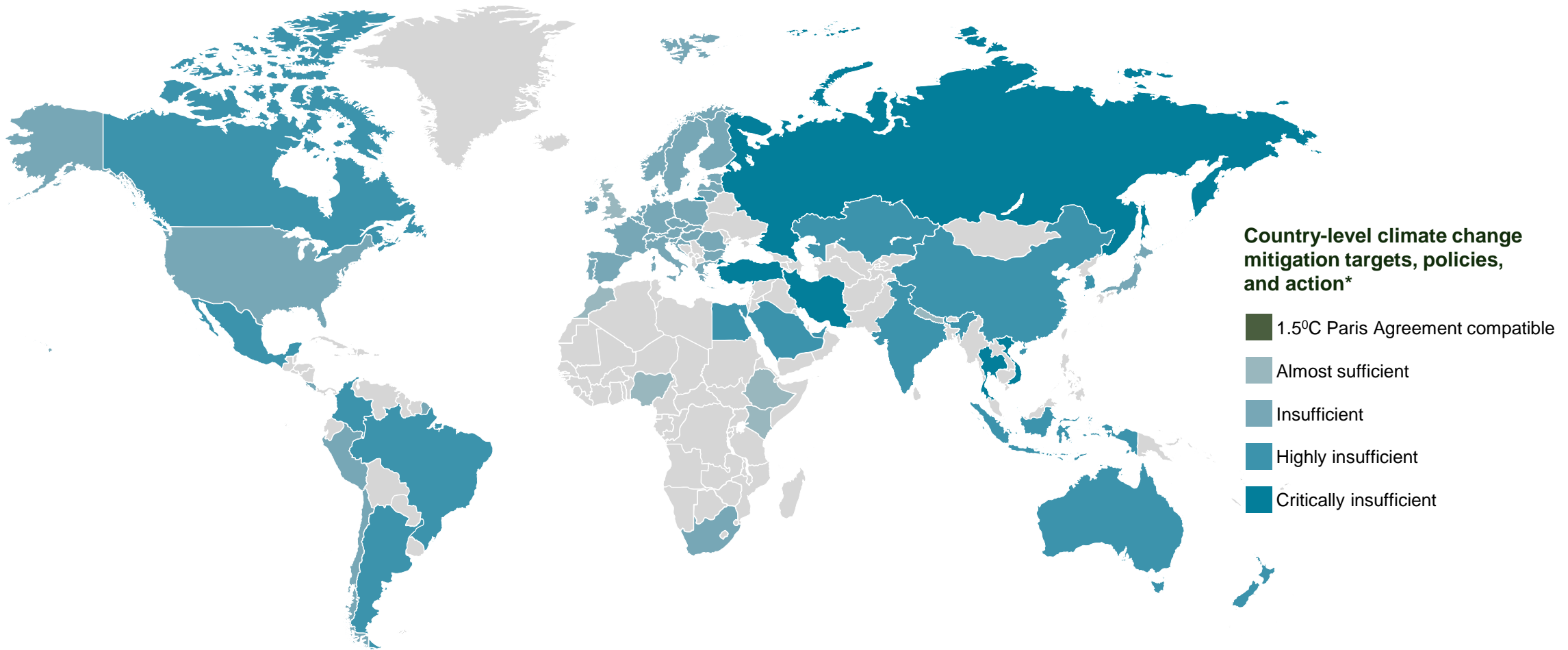

Note: * Measured against globally agreed Paris Agreement aim of "holding warming well below 2°C, and pursuing efforts to limit warming to 1.5°C."
 Source: Climate Action Tracker (updated March 2022)



Policy

However, the Climate Outlook Through 2100 Has Improved, Due At Least in Part to Action Spurred by Paris

Global temperature increase in 2100

By year of estimate based on implemented policies (median)

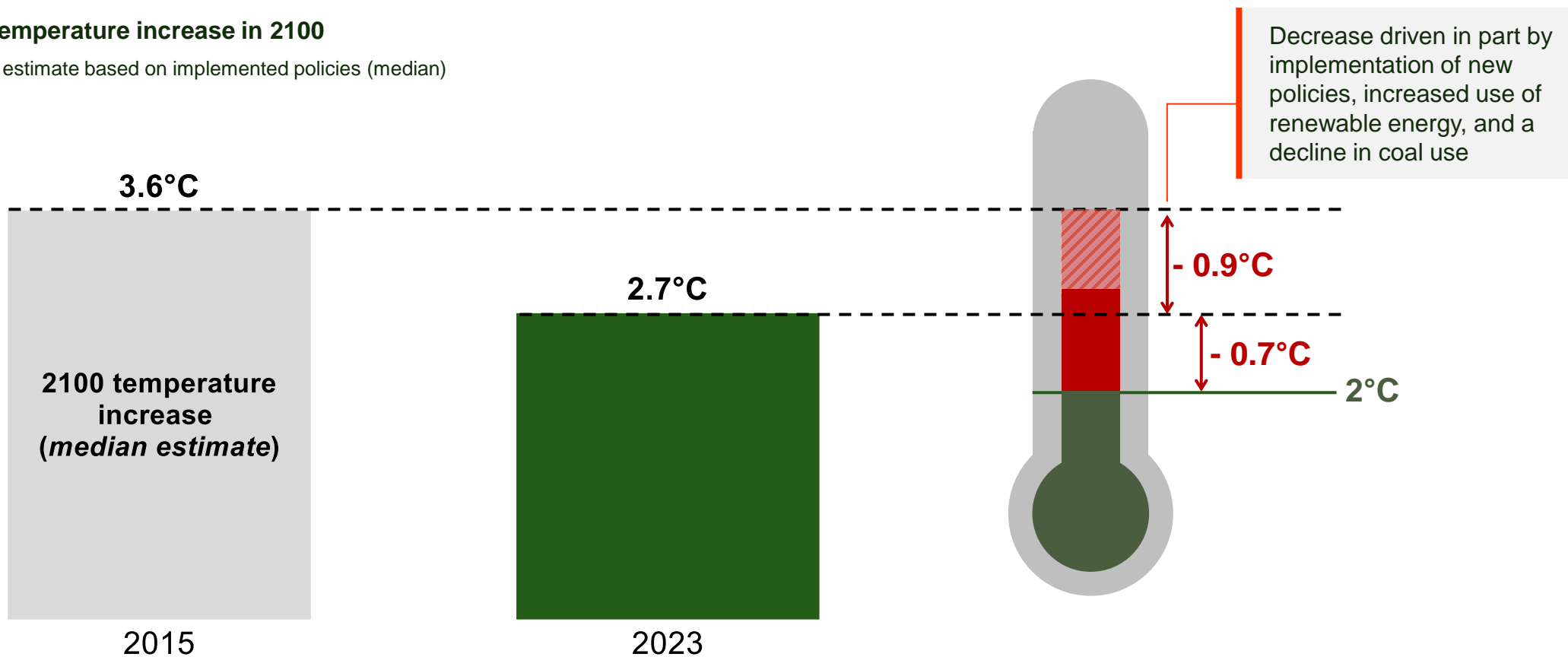

Note: Temperature estimates reflect end-of-century warming above the pre-industrial average based on implemented policies
Source: Climate Action Tracker, "Paris Agreement turning point", December 2020

5

The United Kingdom and Germany Have Each Cut CO₂ Emissions Significantly Since 1990

Change in CO₂ emissions, 1990-2019

PRODUCTION-BASED* EMISSIONS, EXCLUDING LAND USE CHANGE

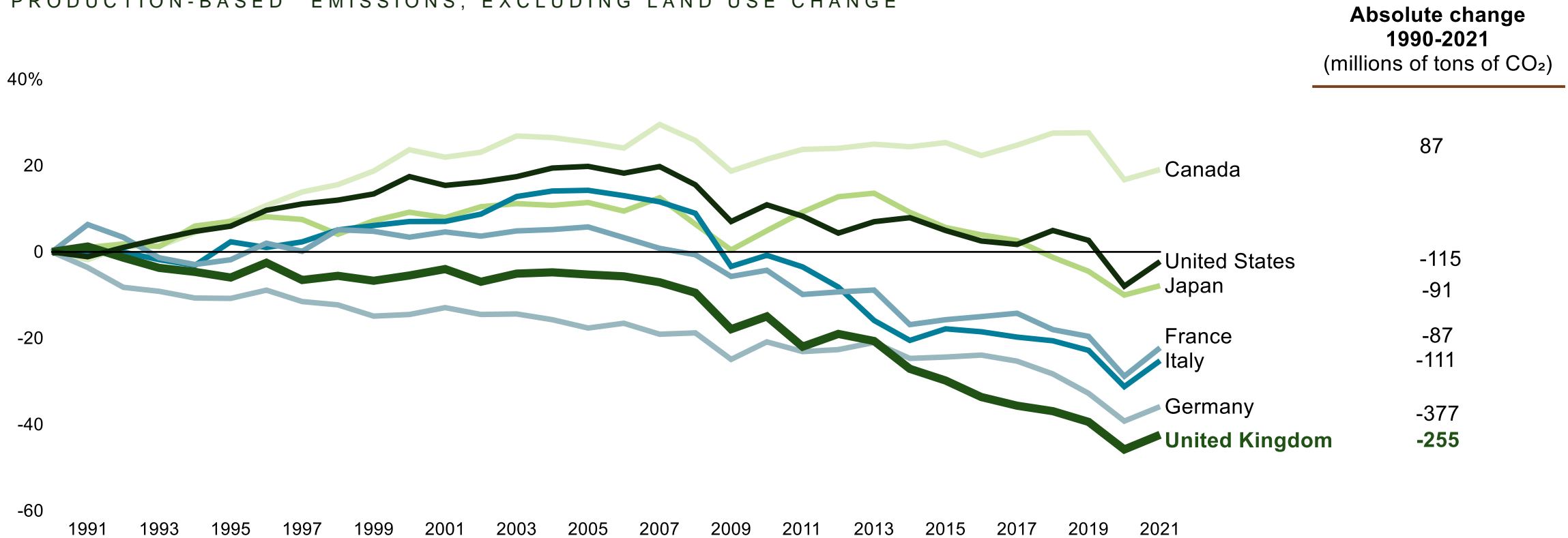

Note: Production-based emissions are not adjusted for trade (i.e., do not factor in emissions embedded in exports or imports)

Source: Global Carbon Project



In Both Cases, Emissions Reductions Occurred in Parallel with Meaningful Economic and Population Growth

Change in GDP, CO₂ emissions, and population, 1990-2021 for select countries

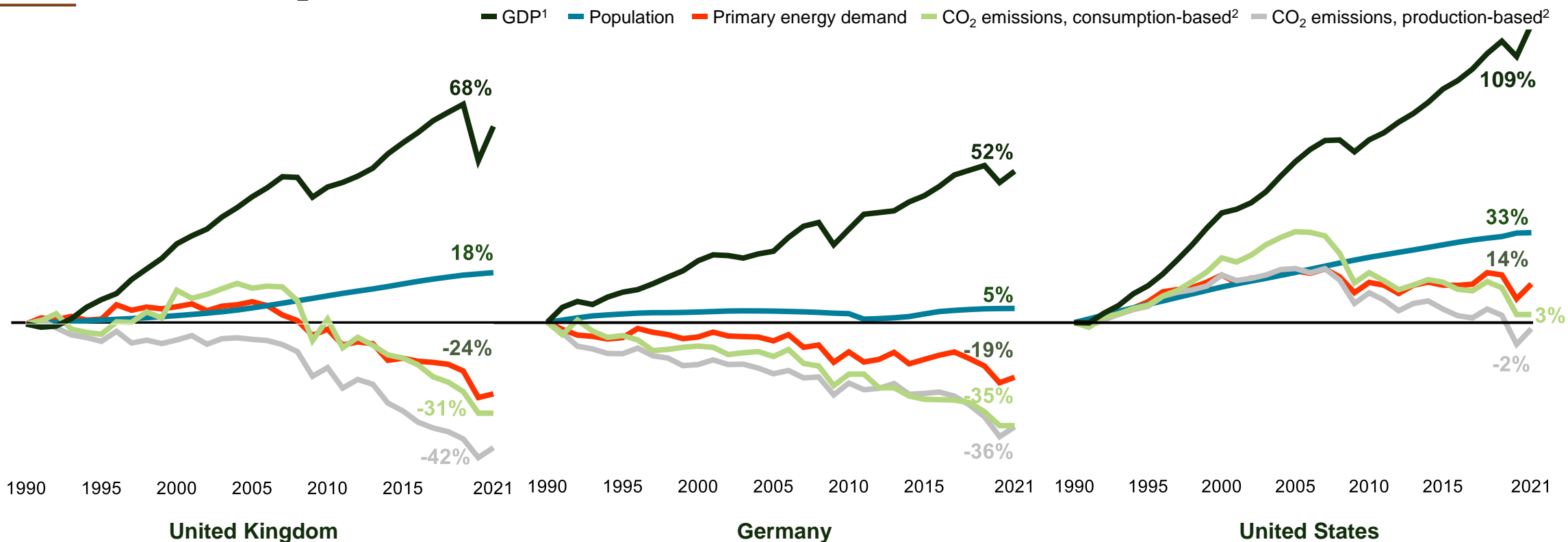

Note: (1) GDP is measured in real 2015 US dollars; (2) consumption-based emissions are adjusted for trade (i.e., production emissions minus emissions embedded in exports plus emissions embedded in imports), and neither consumption-based nor production-based include emissions from land use change

Source: World Bank; Global Carbon Project; BP Statistical Review of World Energy, 2021



Germany is an Example of a Country with a Strong Political Commitment to Transition Away from Fossil Fuels

Germany's transition has been underway since the early 2000s

- ✓ In 2000, Germany embarked on an ambitious plan (*Energiewende*) to transition from fossil fuels to renewables
- ✓ The objective: Generate almost all electricity from renewable sources by 2035, in service of a broader 2045 net-zero target
- ✓ As part of this plan, Germany plans to retire its nuclear and coal fleets by 2022 and 2030, respectively

The result so far: meaningful progress in shifting electricity production to renewable sources

Germany electricity production by source

T W H

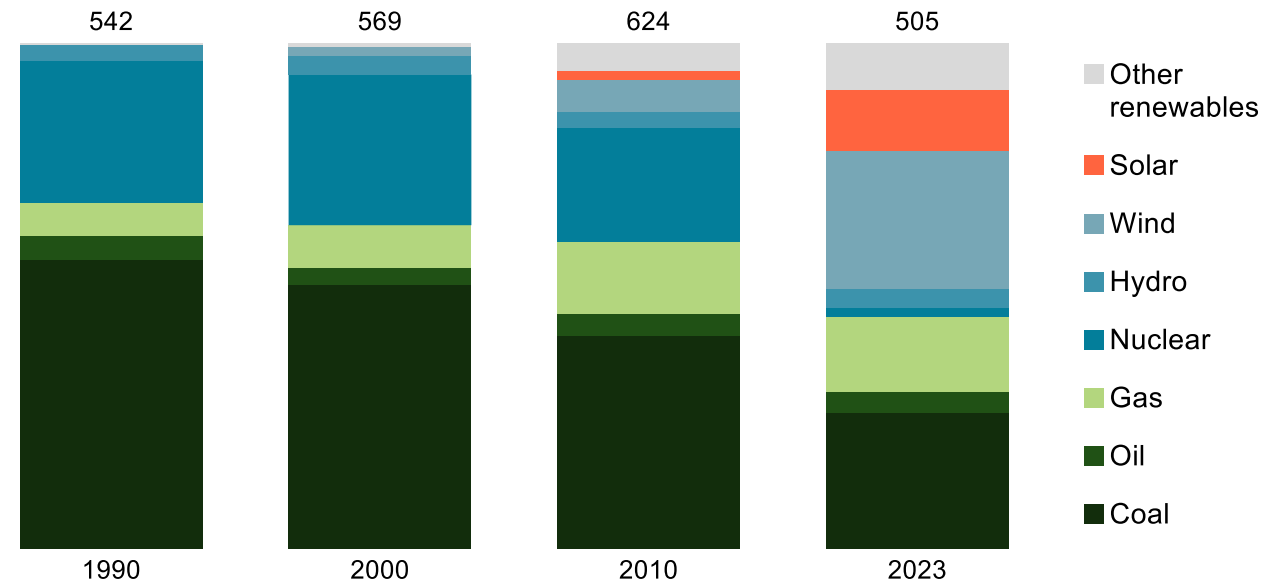

Note: "Renewables" includes hydro, wind, solar, and other renewables (e.g., bioenergy)

Source: Our World in Data; BP Statistical Review of World Energy, 2021; Ember Global Electricity Review (2022); Bloomberg

5

But the Impact of *Energiewende* on Germany's Overall Energy Consumption (Not Just Electricity) Has Been More Muted

Germany primary energy consumption by source

T W H



Renewables %	1%	3%	8%	24%
Fossil fuel %	88%	85%	82%	76%

Note: "Renewables" includes hydro, wind, solar, and other renewables (e.g., bioenergy)
 Source: Our World in Data; BP Statistical Review of World Energy, 2021



Policy



And With The Transition to Wind & Solar, Germany has Had to Maintain All of Its Fossil Fuel Generation Capacity

Germany electricity generation capacity
(measured in gigawatts, shown as bars)

Solar + wind share of German electricity production
(% of electricity generation in terawatt-hours, shown as line)

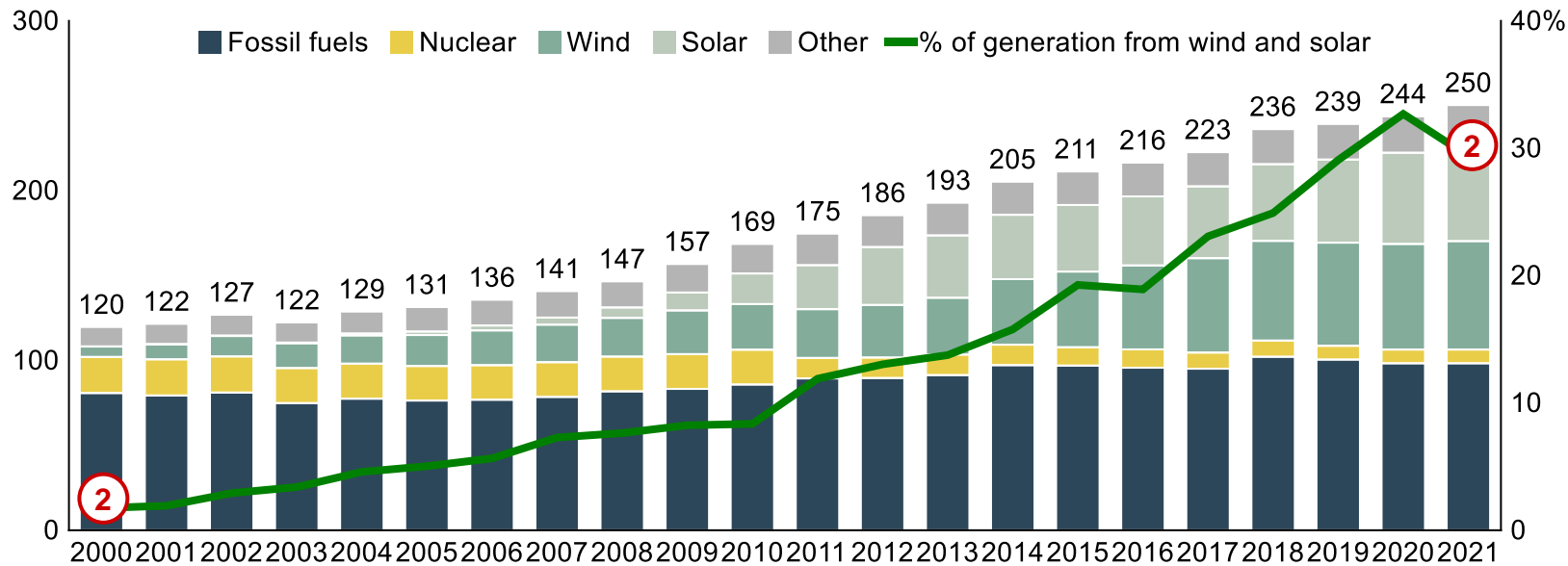

Fossil fuel capacity (GW)

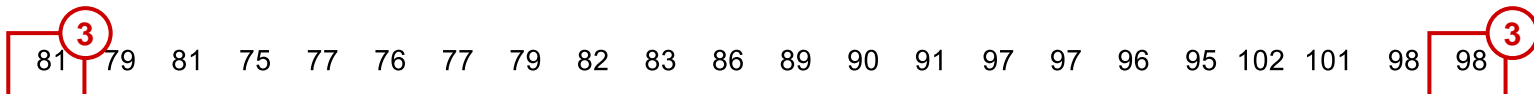

Total generation (TWh)

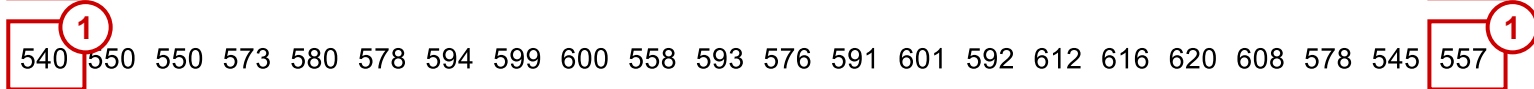

- ① Over 2000-2021, total electricity *generation* (TWh) in Germany grew 3%
- ② Over the same period, wind and solar's share of *generation* expanded from 2% to 30%, on 116 GW of capacity additions
- ③ Despite the wind and solar expansion and roughly flat total electricity generation, fossil fuel generation *capacity* (GW) grew 20%

Source: [EIA](#)



Policy

The UK's Emissions Decline Unfolded Against a Backdrop of Comprehensive Climate Policy, Including Carbon Pricing

United Kingdom CO₂ emissions

MILLIONS OF TONS OF CO₂; EXCLUDES NON-CO₂ EMISSIONS

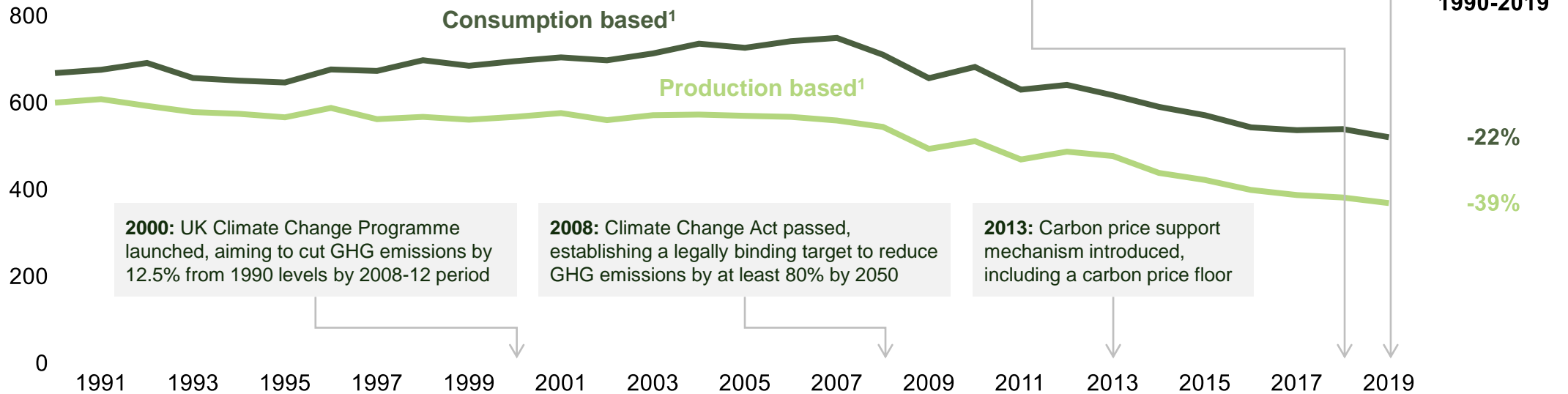

Emissions per capita²	12 tons / cap	11	12	12	11	9	8	-33%
Emissions per GDP²	0.37 kg / \$	0.33	0.30	0.28	0.26	0.19	0.16	-56%

Note: (1) Consumption-based emissions are adjusted for trade (i.e., production emissions minus emissions embedded in exports plus emissions embedded in imports); (2) denominator of data row figures reflects consumption-based CO₂ emissions, and GDP is measured in 2015 real USD

Source: World Bank; Global Carbon Project; Gov.uk, UK becomes first major economy to pass net zero emissions law (2019); UK Parliament, Carbon Price Floor (CPF) and the price support mechanism (2018)

5

UK Emissions Reductions Stemmed from Several Sources, Notably Cleaner Power Generation and Reduced Energy Use

UK CO₂ emissions, 1990-2019

MILLIONS OF TONS OF CO₂; EXCLUDES NON-CO₂ EMISSIONS

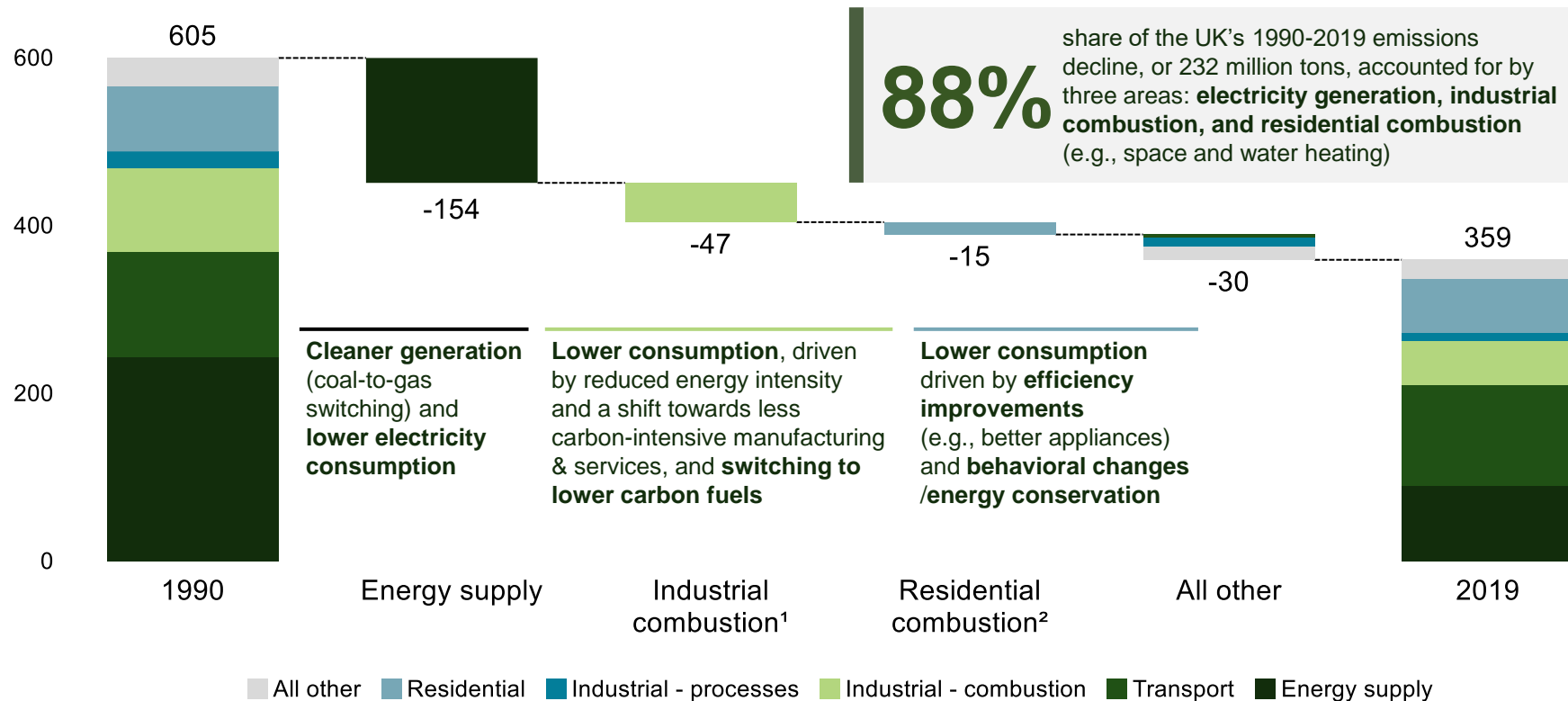

1990-2019	
% change	Share of total change
-41%	6%
-19%	6%
-50%	4%
-47%	19%
-3%	2%
-63%	63%
-40%	100%

Note: (1) Industrial combustion includes fossil fuel combustion in iron/steel production, chemicals manufacturing, cement production, and other industrial processes; (2) Residential combustion includes fossil fuel (primarily natural gas) combustion for space and water heating. Source: UK Department for Business, Energy, & Industrial Strategy, Final UK greenhouse gas emissions national statistics: 1990 to 2020



Coal-to-Gas Switching in Power Generation Was a Major Source of UK Emissions Reductions, Driven in Part by Climate Policy

Over 1990-2021, UK electricity production from coal dropped by 97% and was replaced mostly by gas

United Kingdom electricity production by generation source

T W H

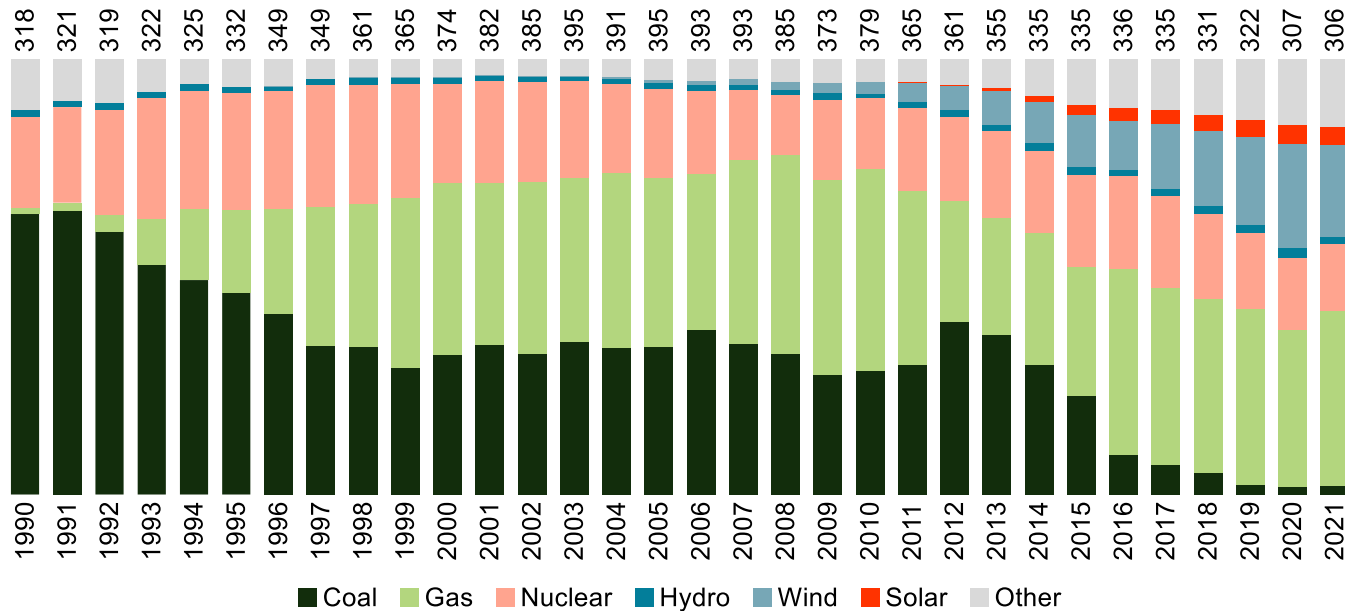

This switch was partially driven by climate change policy

1990s: Coal power generation drops by 50%, a result of the “dash for gas”. **This was not an achievement of climate change policy;** rather, it was triggered by privatization in the UK electricity supply

2010s: Coal power generation falls by a further 93%, largely a consequence of **increased renewables output**, due in turn to **falling costs** and **government subsidies**, and **carbon price support** (i.e., a carbon tax), which together made coal uncompetitive

Lifecycle greenhouse gas emissions

G OF CO₂ - EQUIVALENT PER KWH

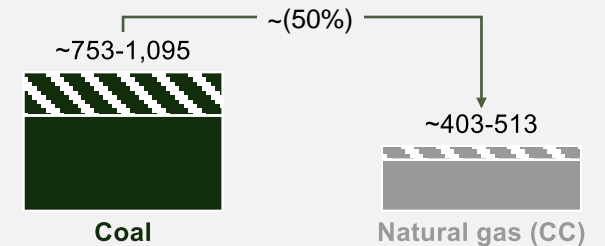

Note: Other includes other renewables (e.g., bioenergy). Source: Our World in Data; BP Statistical Review of World Energy, 2021; Sheffield Hallam University, Coal Transition in the United Kingdom (2017); UN Economic Commission for Europe, Life Cycle Assessment of Electricity Generation Options (2021)



5

Lower Overall Energy Use Has Also Played a Role: the UK Consumes Less Energy Today Than It Did 50 Years Ago

Change in primary energy demand, 1990-2021

-25% change in the UK's primary energy demand between 1970 and 2021

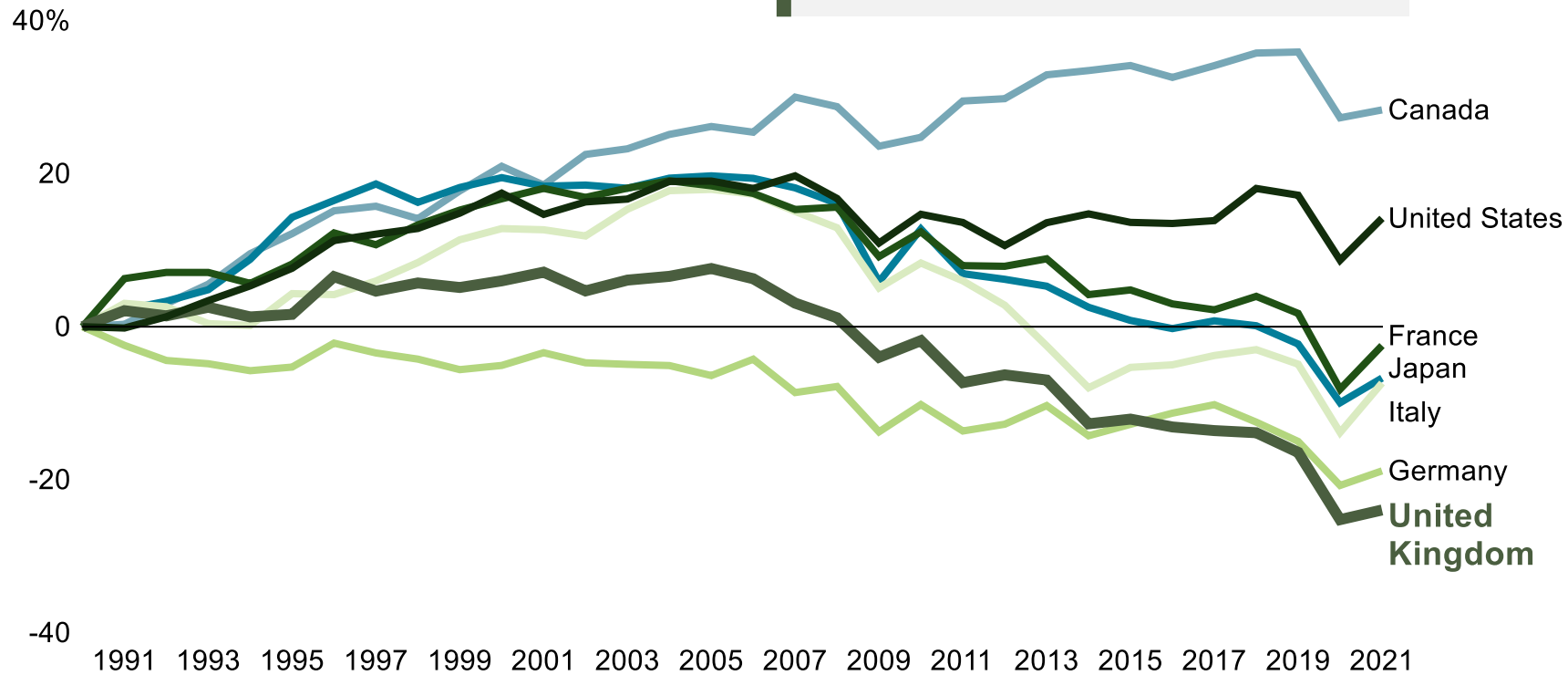

	% change	
	1990-2021	2005-2021
Canada	28%	2%
United States	14%	-4%
France	-2%	-18%
Japan	-7%	-22%
Italy	-7%	-21%
Germany	-19%	-13%
United Kingdom	-24%	-29%

Note: Production-based emissions are not adjusted for trade (i.e., do not factor in emissions embedded in exports or imports)
 Source: Our World in Data; Global Carbon Project



5

Energy Supplied by All Fuel Sources, Except Renewables, is Down Meaningfully Since the Mid-2000s

UK primary energy demand

TERAWATT-HOURS

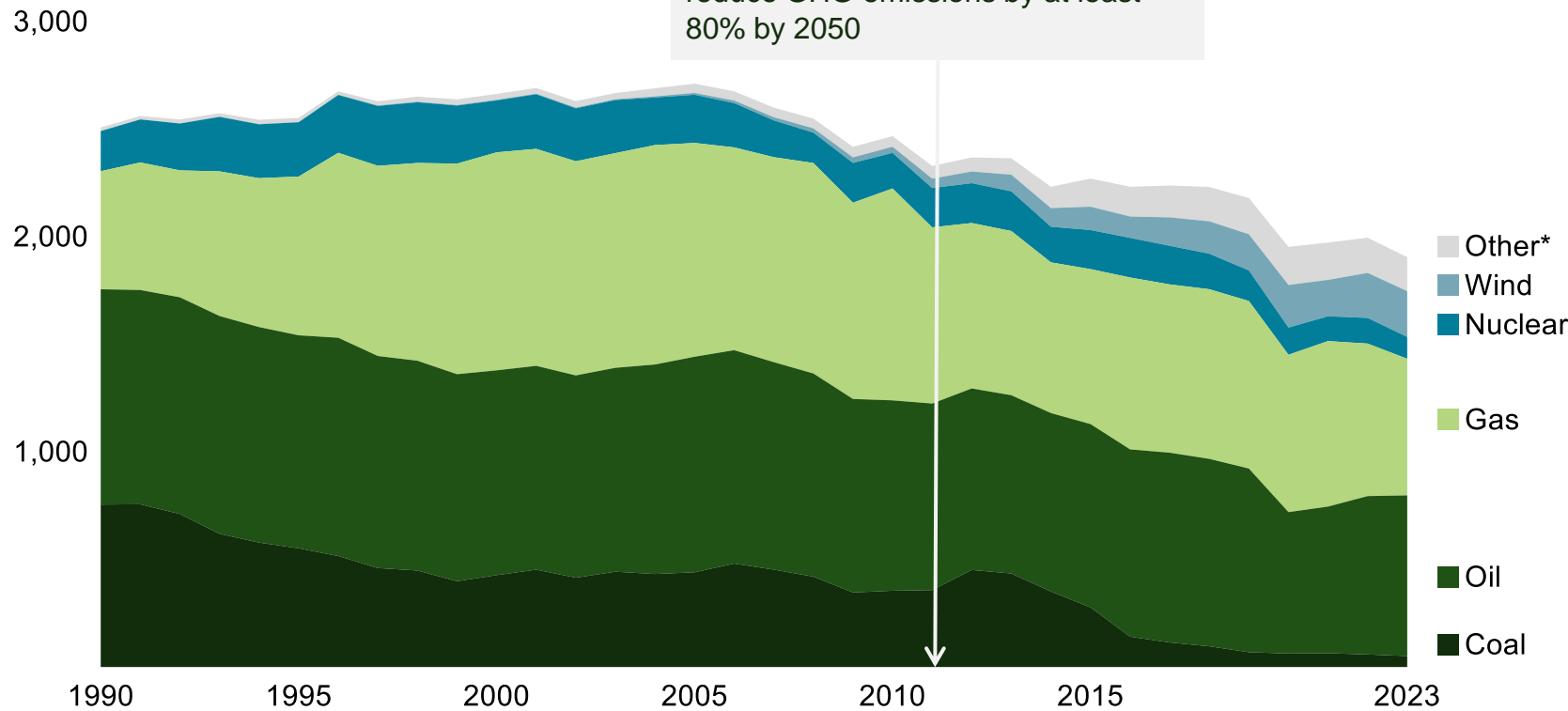

	% change	
	1990-2023	2005-2023
Other*	--	--
Wind	--	--
Nuclear	-46%	-55%
Gas	16%	-36%
Oil	-25%	-25%
Coal	-93%	-88%
Total (excluding Renewables)	-24%	-30%

Note: Other includes solar, hydro, and other renewables (e.g., bioenergy)
 Source: Our World in Data; BP Statistical Review of World Energy, 2021



5

Overall, the UK has Reduced its Reliance on Fossil Fuels Modestly but Remains Heavily Dependent

UK primary energy consumption by source

T W H

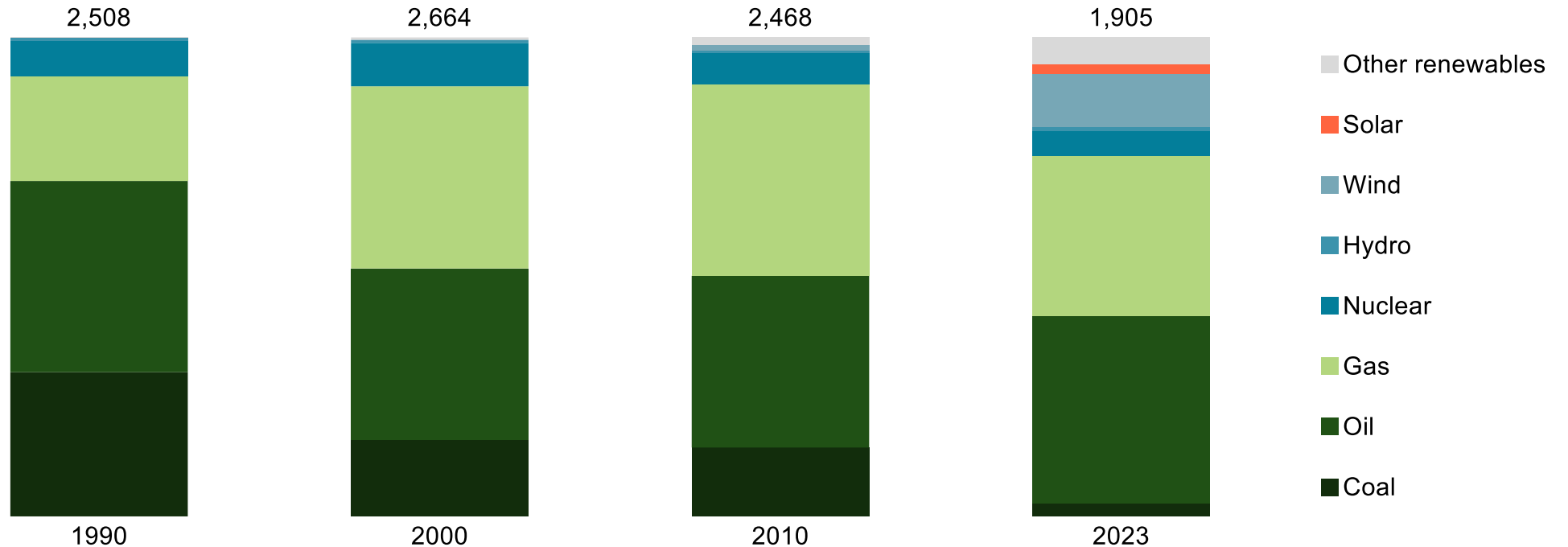

Renewables %	1%	1%	3%	19%
Fossil fuel %	92%	90%	90%	75%

Note: "Renewables" includes hydro, wind, solar, biofuels, and other renewable sources
 Source: Our World in Data; BP Statistical Review of World Energy, 2021



Contrasting the Approach of Germany With That of the US Reveals the Challenges of Decarbonizing

		Germany	United States
	Energy transition pathway	Deliberate, highly centralized, government-led with targets and mandates	No-target, no-mandate, market-driven
Significantly reduce emissions	Fossil fuels as share of primary energy supply	-7 pts (86% to 79%, 2000-21)	-6 pts (88% to 82%, 2000-21)
	Renewables as share of electricity production	+34 pts (6% to 41%, 2000-21)	+12 pts (9% to 21%, 2000-21)
	Total GHG emissions	-15% (951M tons of CO ₂ -e to 812M, 2000-18)	-10% (6,594M tons of CO ₂ -e to 5,939B, 2000-18)
	GHG emissions per capita	-15% (11.6t CO ₂ -e to 9.8, 2000-18)	-22% (23.4t CO ₂ -e to 18.2, 2000-18)
Deliver affordable, reliable, secure energy	Residential electricity price	+139% (€0.13/kWh to €0.31/kWh, 2000-21)	+67% (\$0.08/kWh to \$0.14/kWh, 2000-21)
	Industrial electricity price	+270% (€0.05/kWh to €0.19/kWh, 2000-21)	+59% (\$0.05/kWh to \$0.07/kWh, 2000-21)
	Energy dependence*	More dependent (61% to 70%, 2000-19)	Less dependent (27% to -2%, 2000-19)

Note: * Energy dependence = (energy imports – energy exports) / total primary consumption, measured in millions of tons of oil equivalent (Mtoe)
Source: Euromonitor; Eurostat; Enerdata; CAIT; World Bank; BP Statistical Review of World Energy, 2021

Progress in Both Germany and the UK Has Come at a Cost: Electricity Prices Have Risen Rapidly in Both Countries

Residential electricity price

LOCAL CURRENCY PER MWH, INDEXED TO 2000 = 100

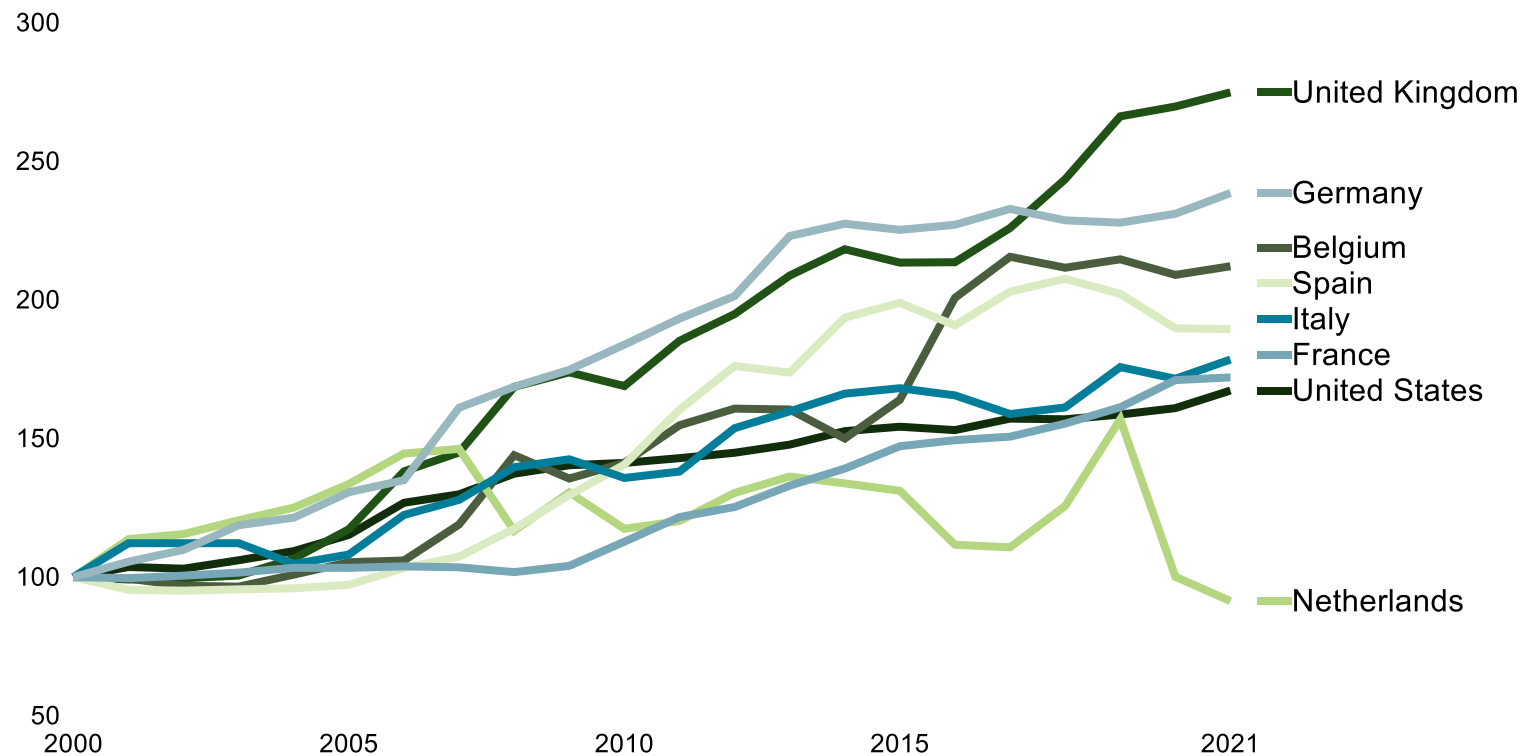

	2000-2021 growth	2021 price in local currency	2021 price in USD
United Kingdom	175%	£194	\$261
Germany	139%	€312	\$357
Belgium	112%	€279	\$319
Spain	89%	€241	\$276
Italy	79%	€262	\$300
France	72%	€190	\$217
United States	67%	\$137	\$137
Netherlands	-9%	€130	\$149

Note: Prices are measured in current (rather than constant) currency. USA data is in USD; all other countries are in EUR
Source: Euromonitor



It Is Critically Important for Developing Countries to Participate In the Global Decarbonization Project

India and low-income developing countries' annual CO₂ emissions could grow by nearly 10 billion tons by 2050, about the amount emitted by all advanced economies in 2019, given population growth projections and assuming CO₂ emissions per capita reach the level of emerging economies like Mexico and Botswana

Future emissions for select developing countries			India	Low-income developing countries	Total
2022	Population		1.4 billion	1.6 billion	3.0 billion
	Emissions per capita (actual)	✘	1.9 tons/person	0.6 tons/person	1.2 tons/person
	Total CO ₂ emissions	=	2.7 billion tons	0.9 billion tons	3.6 billion tons
2050	Population (UN forecast)		1.7 billion	2.7 billion	4.3 billion
	Emissions per capita (assumed)	✘	3.0 tons/person	3.0 tons/person	3.0 tons/person
	Total CO ₂ emissions	=	5 billion tons	8 billion tons	13 billion tons

Mexico, Botswana, and Jamaica each emit about 3 tons per capita today

Note: Emissions and emissions per capita are production-based CO₂ (excludes non-CO₂ emissions like methane); low-income developing countries are those with per capita income levels below \$2,700 (2016 \$), structural features consistent with limited development, and insufficiently close external financial linkages to be seen as emerging market economies. Source: Global Carbon Project; UN Population Division; IMF

Across Nations, Energy Security Is An Increasingly Important Policy Concern

Of the top 10 economies (countries by GDP),
8 were dependent on energy imports

The Winter 2021-22 energy crunch, and Russia's invasion of Ukraine, **shined a spotlight on energy security risk for importers**

Shortage conditions drove energy prices up 5-10X, creating inflationary pressure, demand destruction, and unpredictability

There are two pathways countries will consider to sustain or increase energy supply:

- **Path 1:** Focus on security of supply of fossil fuels – minimize counterparty risk, at reasonable cost
- **Path 2:** Transition more quickly to renewable fuels to address *both* climate change *and* energy security

Commodity prices

SHOWN FOR SELECT COMMODITIES,
INDEXED TO MAR 2021 = 1.0

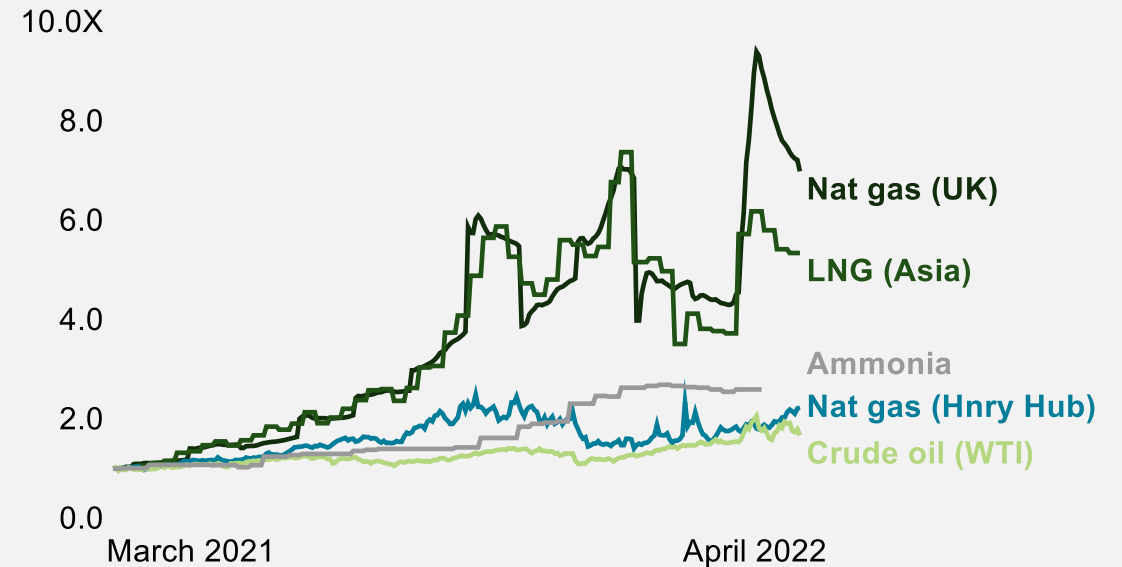

Energy security is likely to be a **key macro consideration for the foreseeable future** and will shape responses to the **“dual challenge”** for developed and developing economies

Source: Refinitiv, Eikon, World Bank

5

Some Clean Solutions Come With Their Own Set of Security Concerns; Electrical Vehicle Batteries Are An Example

China dominates the entire downstream EV battery supply Chain

Geographical distribution of the global EV battery supply chain

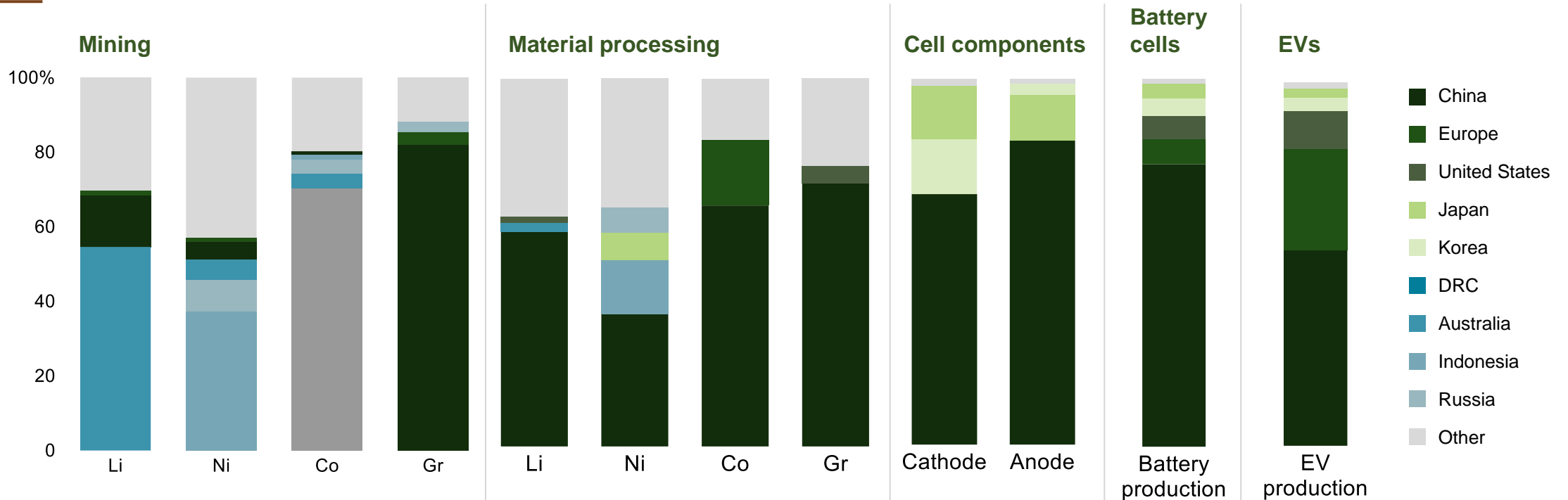

Note: Li=lithium; Ni=nickel; Co=cobalt; Gr=graphite; DRC=Democratic Republic of Congo. Geographical breakdown refers to the country where the production occurs. Mining is based on production data. Material processing is based on refining production capacity data. Cell component production is based on cathode and anode material production capacity data. Battery cell production is based on battery cell production capacity data. EV production is based on EV production data. Although Indonesia produces around 40% of total nickel, little of this is currently used in the EV battery supply chain. The largest Class 1 battery-grade nickel producers are Russia, Canada and Australia. Source: IEA analysis based on: EV Volumes; US Geological Survey (2022); Benchmark Mineral Intelligence; Bloomberg NEF

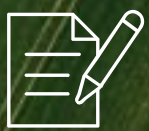

Production of Minerals Key to Low Carbon Tech is Highly Concentrated, More So than Oil and Gas

Share of top three producing countries in production of selected minerals and fossil fuels, 2019

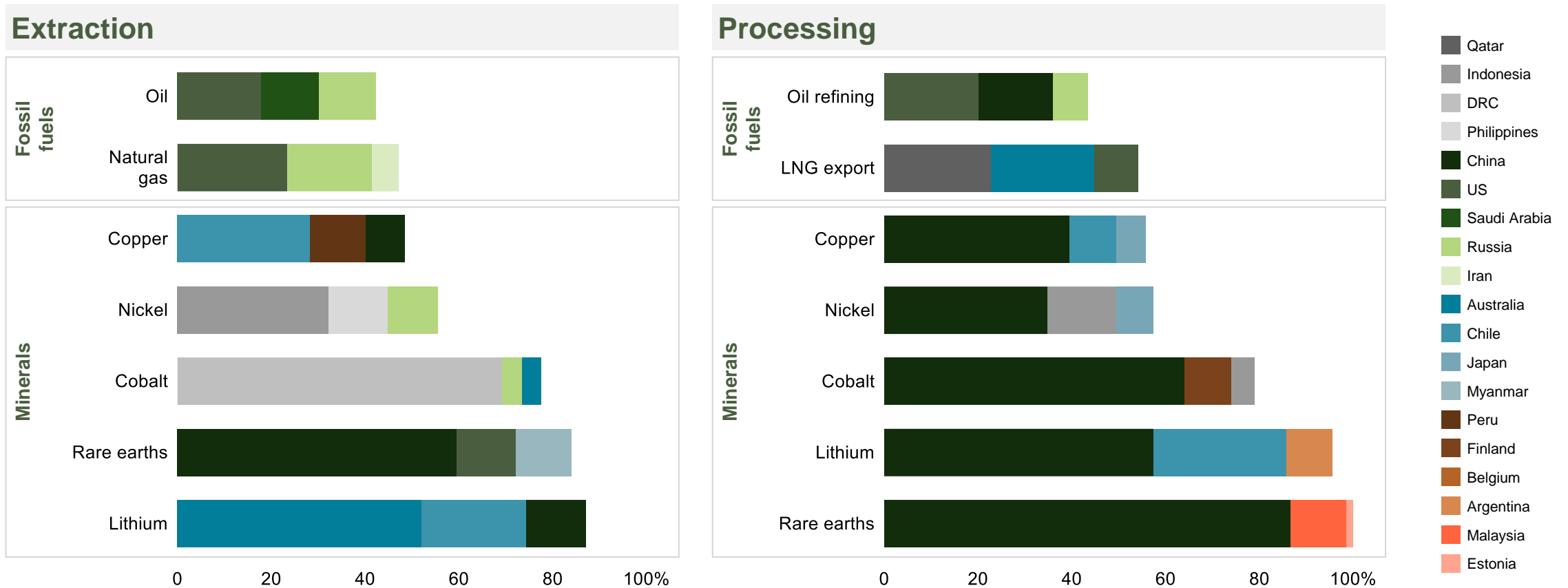

Note: LNG = liquefied natural gas; US = United States. The values for copper processing are for refining operations
 Source: IEA, The Role of Critical Minerals in the Energy Transition (2021), license: Creative Commons Attribution CC BY-NC-SA 3.0 IGO

5

In Developing Countries, “Affordable, Reliable, Secure” Have Historically Been Prioritized Over “Clean” in Energy

In the “calculus” of energy decisions, developing countries have historically **prioritized affordability, reliability, and security over clean/green**

Coal was, and to a certain degree remains, **the solution of choice to satisfy increasing electricity demand** in many countries, particularly in Asia

- China and India were almost entirely responsible for the doubling in global coal-fired power capacity over 2000-2019
- Today, there are nearly 200 coal plants under construction in Asia

In these countries, the expansion in energy supply driven by coal contributed meaningfully to **GDP growth** and **improvements in living standards**

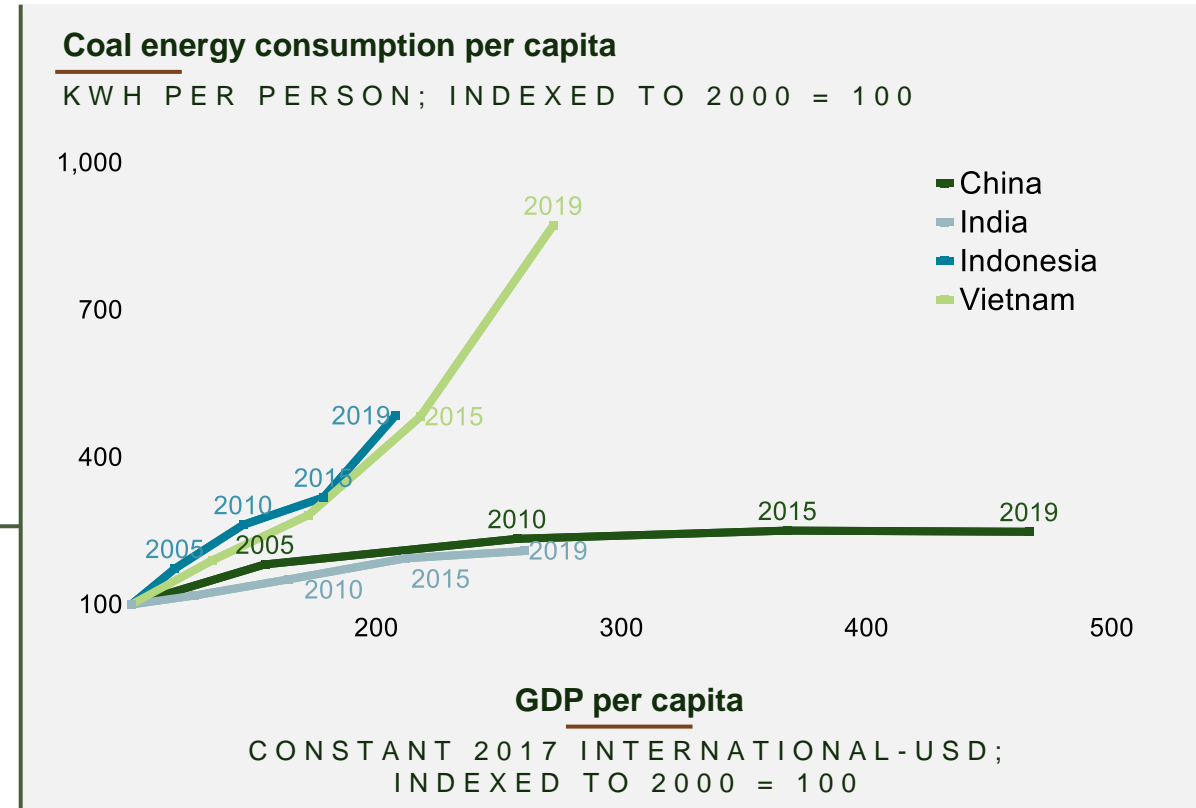

In the **absence of viable alternative solutions** (i.e., as affordable, as reliable, and as secure), many countries will **continue to rely on fossil energy sources**



We cannot significantly reduce emissions without viable energy solutions for developing countries

Source: IEA; IMF; World Bank; BP Statistical Review of World Energy, 2021; Reuters

Looking at Living Standards in Developing Countries, It Is Understandable Why

Metric	 Nigeria	 United States	Difference
Population¹	206 million	329 million	--
Gross national income per capita¹ (current USD)	\$2,030	\$65,970	33X higher in USA
Energy consumption per capita² (MWh per year)	2.4	77.5	29X higher in USA
Share of population with electricity access¹	55%	100%	45 pts higher in USA
Life expectancy at birth¹	55	79	24 years higher in USA
Mean years of schooling³	6.7	13.4	6.7 more years in USA
Infant mortality rate¹ (per 1,000 live births)	72	5	14X lower in the USA
Poverty rate³ (% of population living below \$1.90/day, 2011 PPP)	39%	1%	39X lower in the USA

Source: (1) World Bank (infant mortality rate; poverty rate, access to electricity); (2) BP Statistical Review of World Energy; (3) UN Development Programme (Human Development Index)

5

There Are Promising Signs—Countries Accounting for 90% of Global GHG Emissions Have Made Net Zero Pledges

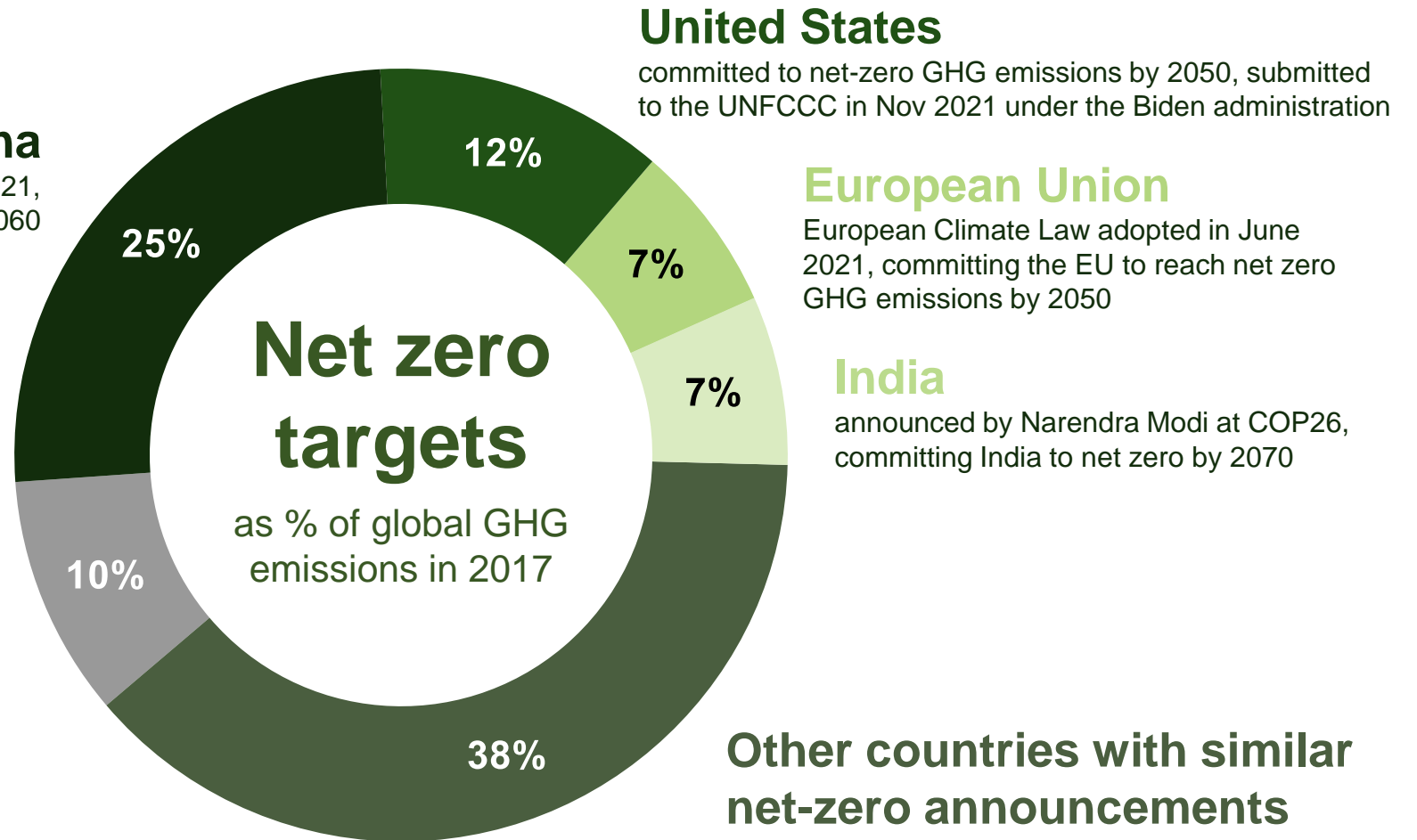

Countries with no net-zero target

China
submitted to the UNFCCC in Oct 2021, committing to net zero CO₂ emissions by 2060

United States
committed to net-zero GHG emissions by 2050, submitted to the UNFCCC in Nov 2021 under the Biden administration

European Union
European Climate Law adopted in June 2021, committing the EU to reach net zero GHG emissions by 2050

India
announced by Narendra Modi at COP26, committing India to net zero by 2070

Other countries with similar net-zero announcements

Net zero targets
as % of global GHG emissions in 2017

Note: UNFCCC = United Nations Framework Convention on Climate Change
Source: Climate Action Tracker



In the US, the Inflation Reduction Act (IRA) is a Breakthrough Policy Shift

The IRA is the most significant climate action ever taken by Congress

- ✓ The Act includes \$369B of investment over 10 years directed toward reducing emissions and improving climate resilience
- ✓ Specifically, the Act includes new or extended tax credits for hydrogen, wind, solar, nuclear, geothermal, electric vehicles, and carbon capture, among other provisions
- ✓ The Act also includes provisions for continued investment in oil & gas with geopolitical and energy security interests in mind

It will bring the US within striking distance of its Paris Agreement target

US greenhouse gas emissions percent reduction in 2030 from 2005 levels, Rhodium Group estimates

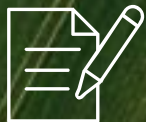
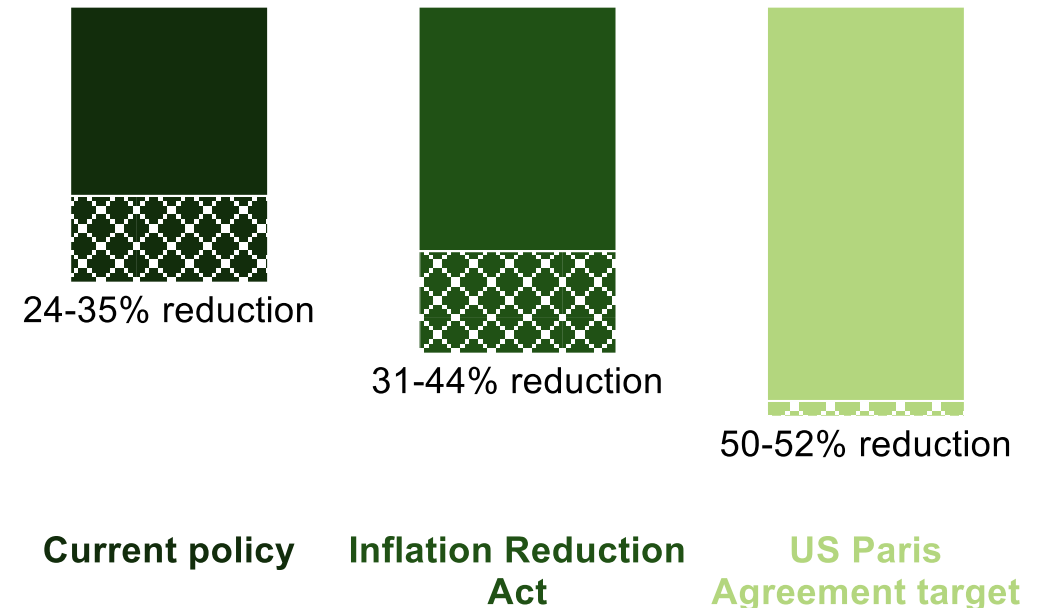

The Dual Challenge: Headwinds and Tailwinds



Achieving “clean” without compromising “reliable, affordable, secure” is at the core of the Dual Challenge



The momentum case based on current trend will not be enough, and we need action across policy, technology, corporates, and consumers



We face considerable challenges in each area, such as our deep, longstanding dependence on fossil fuels, and the need for global coordination between countries with different national priorities



However, encouragingly, we see signs of progress, like significant ongoing deployment of wind and solar



We also see clear tailwinds, like broadening commitment among countries and market stakeholders



As we consider solutions to this difficult, global problem, we need visionary—but still pragmatic—voices and system-oriented thinking



Solution portfolios will look different from country to country, shaped by available resources and national priorities, and implementation will span decades

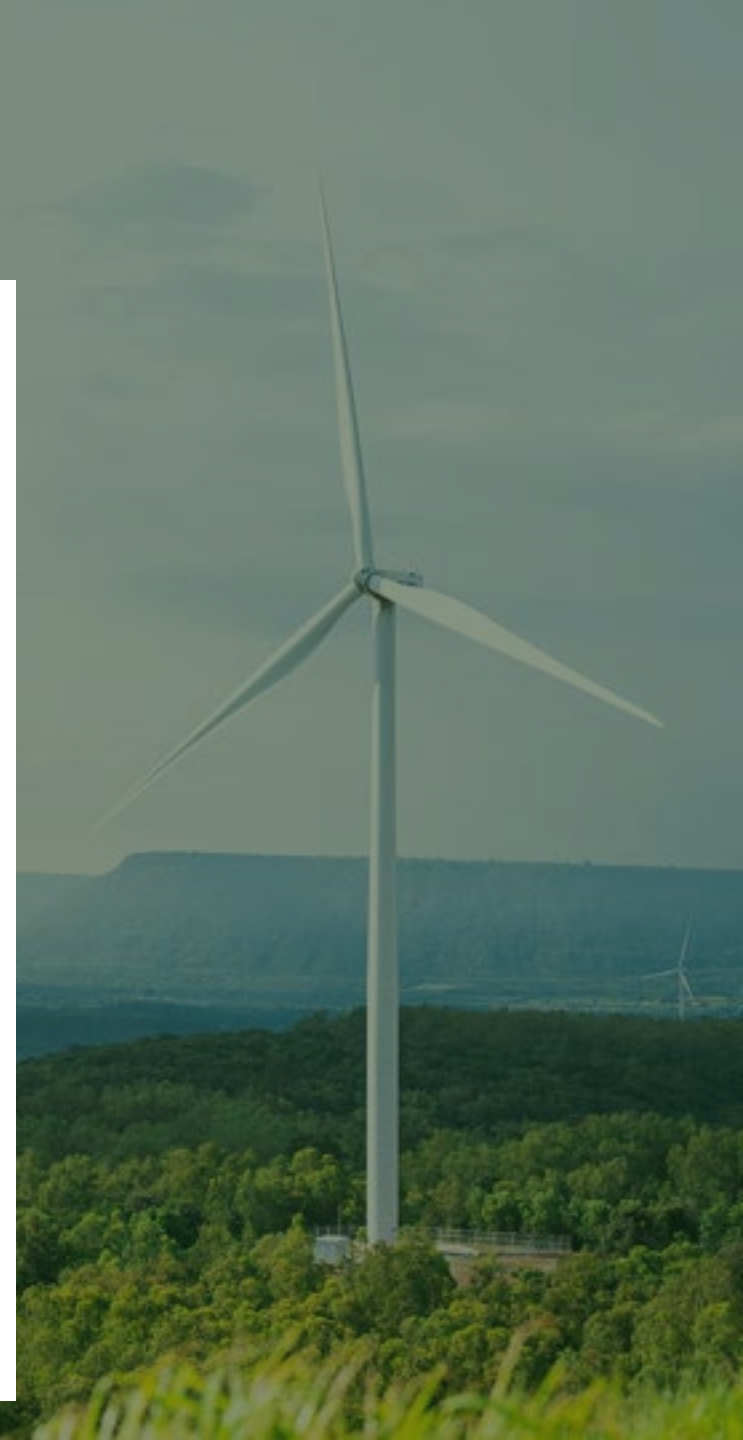

Appendix





General backup

Prefixes and unit conversions

APPENDIX

Common (SI) prefixes

Factor	Name	Symbol
10^1	deka	da
10^2	hecto	h
10^3	kilo	k
10^6	mega	M
10^9	giga	G
10^{12}	tera	T
10^{15}	peta	P
10^{18}	exa	E
10^{21}	zotta	Z
10^{24}	yotta	Y

Energy unit conversions

1 joule	2.78 x 10 ⁻⁴ watt-hours
	1.63 x 10 ⁻¹⁰ BOE
<i>The amount of work done when a force of one newton is displaced through a distance of one meter</i>	2.39 x 10 ⁻¹¹ toe
	9.48 x 10 ⁻⁴ Btu
1 watt-hour	3,600 joules
	5.88 x 10 ⁻⁷ BOE
<i>One watt of power sustained for one hour</i>	8.60 x 10 ⁻⁸ toe
	3.4 Btu
1 BOE (barrel of oil equivalent)	6.12 x 10 ⁹ joules
	1.70 x 10 ⁶ watt-hours
<i>Approximate amount of energy released by burning one barrel (42 gal / 159L) of crude oil</i>	0.15 toe
	5.80 x 10 ⁶ Btu
1 toe (ton of oil equivalent)	4.19 x 10 ¹⁰ joules
	1.16 x 10 ⁷ watt-hours
<i>Approximate amount of energy released by burning one metric ton (1,000 kg) of crude oil</i>	6.84 BOE
	3.97 x 10 ⁷ Btu
1 Btu (British thermal unit)	1,055 joules
	0.29 watt-hours
<i>Defined as the amount of heat required to raise the temperature of one pound of water by one degree</i>	1.72 x 10 ⁻⁷ BOE
	2.52 x 10 ⁻⁸ toe



General backup IMF economy groupings

APPENDIX

The main criteria used by the IMF to classify economies are: (1) per capita income level; (2) export diversification; and (3) degree of integration into the global financial system. **Low-income developing countries** are those with per capita income levels below \$2,700 (2016 \$), structural features consistent with limited development, and insufficiently close external financial linkages to be seen as emerging market economies

Advanced		Emerging				Low-income developing				
Australia	Luxembourg	Albania	Chile	Indonesia	North Macedonia	Grenadines	Afghanistan	Gambia, The	Nicaragua	Vietnam
Austria	Macao SAR	Algeria	China	Iran	Oman	Suriname	Bangladesh	Ghana	Niger	Yemen
Belgium	Malta	Angola	Colombia	Iraq	Pakistan	Syria	Benin	Guinea	Nigeria	Zambia
Canada	Netherlands	Antigua and Barbuda	Costa Rica	Jamaica	Palau	Thailand	Bhutan	Guinea-Bissau	Papua New Guinea	Zimbabwe
Cyprus	New Zealand	Argentina	Croatia	Jordan	Panama	The Bahamas	Burkina Faso	Haiti	Guinea	
Czech Republic	Norway	Armenia	Dominica	Kazakhstan	Paraguay	Tonga	Burundi	Honduras	Rwanda	
Denmark	Portugal	Aruba	Dominican Republic	Kosovo	Peru	Trinidad and Tobago	Cambodia	Kenya	São Tomé and Príncipe	
Estonia	Puerto Rico	Azerbaijan	Ecuador	Kuwait	Philippines	Tobago	Cameroon	Kiribati	Senegal	
Finland	San Marino	Bahrain	Egypt	Lebanon	Poland	Tunisia	Central African Republic	Kyrgyz Republic	Sierra Leone	
France	Singapore	Barbados	El Salvador	Libya	Qatar	Turkey	Chad	Lao P.D.R.	Solomon Islands	
Germany	Slovak Republic	Belarus	Equatorial Guinea	Malaysia	Romania	Turkmenistan	Comoros	Lesotho	South Sudan	
Greece	Slovenia	Belize	Eswatini	Maldives	Russia	Tuvalu	Congo,	Liberia	Sudan	
Hong Kong SAR	Spain	Bolivia	Fiji	Marshall Islands	Samoa	Ukraine	Democratic Republic of the Congo,	Madagascar	Somalia	
Iceland	Sweden	Bosnia and Herzegovina	Gabon	Mauritius	Saudi Arabia	United Arab Emirates	Republic of the Congo,	Malawi	Sudan	
Ireland	Switzerland	Botswana	Georgia	Mexico	Serbia	Uruguay	Republic of the Congo,	Mali	Tajikistan	
Israel	Taiwan Province of China	Brazil	Grenada	Micronesia	Seychelles	Vanuatu	Republic of the Congo,	Mauritania	Tanzania	
Italy	United Kingdom	Brunei Darussalam	Guatemala	Mongolia	South Africa	Venezuela	Côte d'Ivoire	Moldova	Timor-Leste	
Japan	United States	Bulgaria	Guyana	Montenegro	Sri Lanka		Djibouti	Mozambique	Togo	
Korea		Cabo Verde	Hungary	Morocco	St. Kitts and Nevis		Eritrea	Myanmar	Uganda	
Latvia			India	Namibia	St. Lucia		Ethiopia	Nepal	Uzbekistan	
Lithuania				Nauru	St. Vincent and the					

Source: IMF (<https://www.imf.org/external/pubs/ft/weo/faq.htm#q4b>)



General backup IPCC likelihood and confidence scale

APPENDIX

Likelihood

- Used to express a probabilistic estimate of the occurrence of a single event or outcome (e.g., a climate parameter, observed trend, or projected change)

Likelihood scale

Term	Likelihood of the outcome
Virtually certain	99-100% probability
Very likely	90-100% probability
Likely	66-100% probability
About as likely as not	33-66% probability
Unlikely	0-33% probability
Very unlikely	0-10% probability
Exceptionally unlikely	0-1% probability

Confidence

- Used to synthesize judgment about the validity of findings as determined through evaluation of evidence and agreement

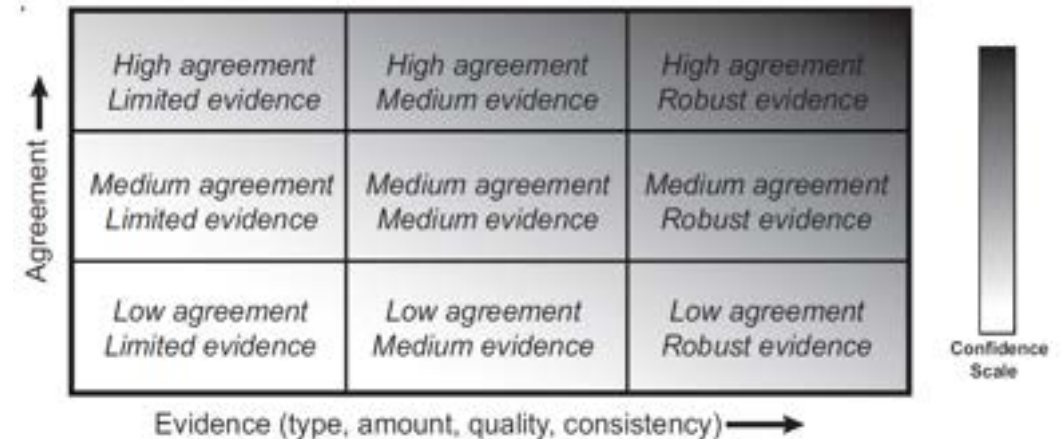



Chapter 2

Energy accounting: There is an important difference between primary energy and final consumption

APPENDIX

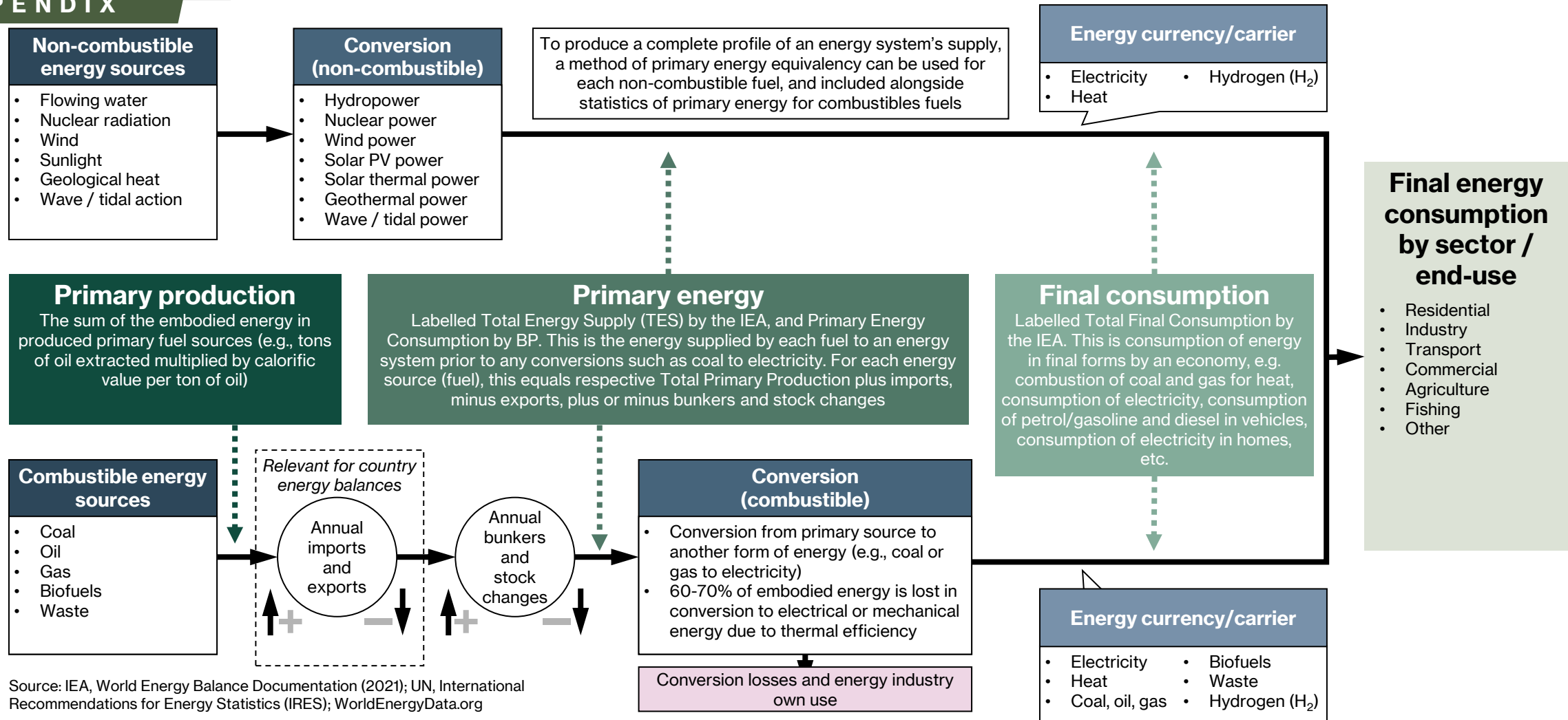

Source: IEA, World Energy Balance Documentation (2021); UN, International Recommendations for Energy Statistics (IRES); WorldEnergyData.org



Chapter 2

Energy accounting: In the US (EIA) example, conversion losses account for 24% of primary consumption

APPENDIX

U.S. energy consumption by source and sector, 2021 (quadrillion British thermal units, Btu)

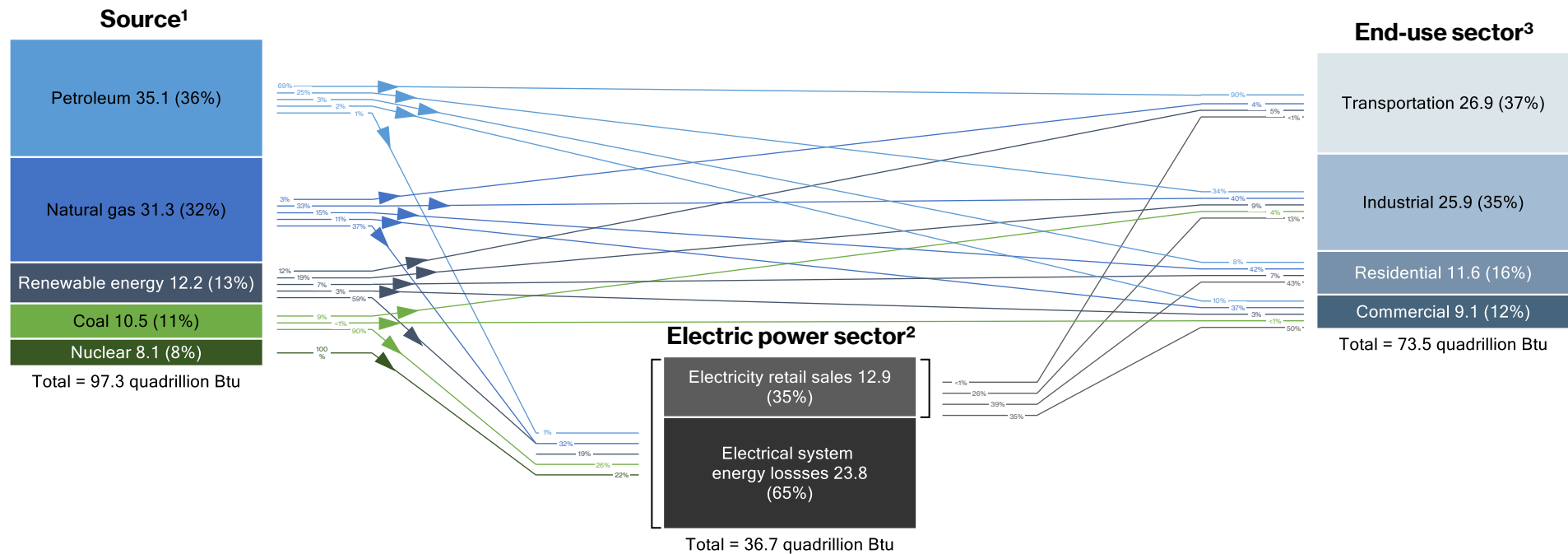

1. Primary energy consumption. Each energy source is measured in different physical units and converted to common British thermal units (Btu). See EIA's *Monthly Energy Review* (MER), Appendix A. Non-combustible renewable energy sources are converted to Btu using the "Fossil Fuel Equivalency Approach", see MER Appendix E.; 2. The electric power sector includes electricity-only and combined-heat-and-power (CHP) plants whose primary business is to sell electricity, or electricity and heat, to the public. Energy consumed by these plants reflects the approximate heat rates for electricity in MER Appendix A. The total includes the heat content of are electricity net imports, not shown separately. Electrical system energy losses calculated as the primary energy consumed by the electric power sector minus the heat content of electricity retail sales. See Note 1, "Electrical System Energy Losses," at the end of MER Section 2.; 3. End-use sector consumption of primary energy and electricity retail sales, excluding electrical system energy losses from electricity retail sales. Industrial and commercial sectors consumption includes primary energy consumption by CHP and electricity-only plants contained within the sector.
 Note: Sum of components may not equal total due to independent rounding. All source and end-use sector consumption data include other energy losses from energy use, transformation, and distribution not separately identified. See "Extended chart notes" on next pages.

Source: U.S Energy Information Administration (EIA), *Monthly energy review* (April 2022), Tables 1.3 and 2.1-2.6



Chapter 2

Energy accounting: Methods for estimating primary energy for nuclear and renewables differ

APPENDIX

There are different primary energy estimation methods for nuclear and renewables

- When measuring electricity generation from renewables or nuclear power, we measure direct output, and the notion of upstream embodied energy is less well-defined vs. fossil fuels
- Consequently, different energy outlook publishers use different methods to compare the primary energy of fossil fuels vs. that of nuclear and renewables. Two such methods are
 - **“Input-equivalent” method:** primary energy for renewables and nuclear is based on the equivalent amount of fossil fuel input required to generate that amount of electricity in a standard thermal power plant
 - > For example, if wind power output for a country was 100 TWh, and the efficiency of a thermal power plant was 38%, the input-equivalent primary energy would be $100/38\% = 263$ TWh
 - > This approach is used by BP and EIA for most forms of non-fossil-based electricity (nuclear, hydro, wind, solar, geothermal, and biomass)
 - **“Captured energy” method:** assumes the primary energy content equals the energy content of the produced electricity for hydropower, wind, solar, and other renewable sources; this approach assumes no energy is lost in the conversion process
 - > For example, if wind power output for a country was 100 TWh, the primary energy would be 100 TWh
 - > This approach is used by IEA

Primary energy conversion efficiency assumptions differ for IEA, EIA, and BP

Primary energy source	IEA (benchmark)	EIA	BP (source most used in this document)
Nuclear	33%	32%	40%
Hydropower	100%	42%	40%
Wind	100%	42%	40%
Solar PV	100%	42%	40%
Geothermal	10%	33%	40%
Biomass	35%	32%	32%

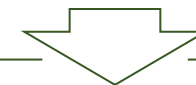

Differences in these assumptions drive differences in total primary energy and the primary energy mix from one source/outlook to another

Source: BP Statistical Review of World Energy Methodology; Resources for the Future, Global Energy Outlook Comparison Methods: 2022 Update



Chapter 2

Energy demand scenario descriptions (1/2)

APPENDIX

Scenario	Description	Projected temperature outcome
Net Zero Emissions by 2050 (NZE)	This scenario is “normative”, in that it was designed to reach a specific outcome, which is net zero energy sector emissions globally by 2050 . The scenario meets key UN Sustainable Development Goals (SDGs), including achieving universal energy access by 2030 and major improvements in air quality.	Global average temperature rise limited to 1.5°C , without a temperature overshoot (with a 50% probability). Temperature peaks around 2050, then stabilizes.
Sustainable Development Scenario (SDS)	Similar to NZE, but the world reaches net zero by 2070 (with many countries and regions achieving net zero much earlier). This scenario is in line with the Paris Agreement and assumes a significant increase in the adoption of clean energy policies , with advanced economies reaching net zero by 2050, China around 2060, and all other countries by 2070	Global average temperature rise limited to 1.65°C , with a 50% probability. With net negative emissions post-2070, the temperature rise could be reduced to 1.5°C in 2100
Announced Pledges Scenario (APS)	This scenario assumes that all governments around the world meet their existing emissions targets on time (with targets set as of mid-2021). Targets include Nationally Determined Contributions (NDCs) and longer-term net zero targets	Global average temperature rise in 2100 is 2.1°C above pre-industrial levels. However, net zero is not achieved , so temperature continues rising thereafter
Stated Policies Scenario (STEPS)	This scenario provides a more conservative benchmark and does not assume all governments will reach their announced goals . Instead, it takes a sector-by-sector approach to explore how the energy ecosystem may evolve under current and under-development policies and with no additional major steer from policy makers.	Global average temperature rise in 2100 is 2.6 °C above pre-industrial levels. However, net zero is not achieved , so temperature continues rising thereafter.
ExxonMobil 2021 Outlook for Energy (XOM)	This scenario is similar to the IEA APS and assumes emissions track within the estimated range of emissions implied by the Nationally Determined Contributions (NDCs) as currently submitted via the Paris Agreement. Total emissions peak by roughly 2030, and by 2050 emissions are ~15% lower versus 2019.	Unclear, but likely between IEA’s STEPS and APS scenarios

Source: IEA World Energy Outlook 2021; ExxonMobil 2021 Outlook for Energy



Chapter 2

Energy demand scenario descriptions (2/2)

APPENDIX

Scenario	GDP growth per annum: 2019-2050	Global population in 2050	Energy demand change: 2019-2050	CO ₂ emissions change: 2019-2050	Peak CO ₂ emissions year
Net Zero Emissions by 2050 (NZE)	About 3.0%	9.7 billion	-12%	-100%	Before 2025
Sustainable Development Scenario (SDS)	About 3.0%	9.7 billion	-6%	-77%	By 2025
Announced Pledges Scenario (APS)	About 3.0%	9.7 billion	+10%	-42%	By 2025
Stated Policies Scenario (STEPS)	About 3.0%	9.7 billion	+21%	-6%	Between 2025- 2030
ExxonMobil 2021 Outlook for Energy (XOM)	About 3.0%	9.7 billion	+15%	-15%	Between 2025- 2030

Source: IEA World Energy Outlook 2021; ExxonMobil 2021 Outlook for Energy



Chapter 3

A note on the Global Warming Potential (GWP) of various greenhouse gases

APPENDIX

- Greenhouse gases (GHGs) act like a blanket insulating the earth: they slow the rate at which energy escapes into space
- Different types of GHGs differ in their warming impact in two key ways:
 - (1) Their ability to absorb energy, or “radiative efficiency”
 - (2) How long they stay in the atmosphere, or “lifetime”
- The Global Warming Potential measure allows us to compare the impact of different types of GHGs versus CO₂
- The larger the GWP, the more a given gas warms the Earth compared to CO₂ over a particular time period
- GWP can be used to calculate the carbon dioxide equivalency (CDE, or CO₂-e) of a particular gas
 - In technical terms, CDE is the time-integrated radiative forcing of a quantity, or rate, of gas emissions

Greenhouse gas	Global anthropogenic emissions (unadjusted, in metric tons)	Global Warming Potential (GWP)			Tons emitted globally, 2019 (in metric tons of CO ₂ -equivalent)
		Radiative efficiency (W*m ⁻² *ppb ⁻¹)	Lifetime (years)	Global Warming Potential over 100 years (GWP-100)	
Carbon dioxide (CO ₂)	36.9 billion	1.3±0.2 x 10 ⁻⁵	Of CO ₂ emitted today, 60% remains after 20 years, 30-55% after 100, and 15-30% after 1,000 years	1	36.9 billion
Methane (CH ₄)	0.36 billion	5.7±1.4 x 10 ⁻⁴ (~40X CO ₂)	11.8±1.8	30±11 (fossil) 27±11 (non-fossil)	~8.6 billion
Nitrous oxide (N ₂ O)	0.09 billion	2.8±1.1 x 10 ⁻³ (~100X CO ₂)	109±10	273±130	~3.1 billion
Fluorinated gases	<1 million	[range] x 10 ⁻¹ , gas dependent (>1000X CO ₂)	5-50 years, gas dependent	2,600 to >8,000, gas dependent	~1.2 billion

Uncertainty ranges are not shown but are large, e.g., ±30% for CH₄ and ±60% for N₂O, and ±30% for f-gases (on a CO₂-e basis) based on IPCC AR6, WG3, Figure SPM.1

Note: Global Warming Potential uncertainties expressed as 5-95% confidence interval based on IPCC AR6. Source: EPA; IPCC, Sixth Assessment Report (AR6), Working Group I, [Chapter 7](#), Table 7.15; IPCC, Fifth Assessment Report (AR5), Working Group I, Box 6.1, [Figure 1](#); Daniel A. Vallero, *Air Pollution Calculations* (2019), [8.3.2](#); [Climate Watch](#)



Chapter 3

IPCC modeled GHG emissions pathways

APPENDIX

IPCC pathway	Description	GHG emissions change: 2050 vs. 2019	Peak GHG emissions year	Cumulative CO ₂ emissions (gigatons), 2020 to net-zero CO ₂ (year achieved)
Trend from implemented policies	<ul style="list-style-type: none"> Pathways with projected near-term GHG emissions in line with policies implemented until the end of 2020 and extended with comparable ambition levels beyond 2030 	-29% (2.5°C, >50%)	2020-2025	1,760 (after 2090)
		-5% (3°C, >50%)	2020-2025	2,790*
		+24% (3.5°C, >50%)	2090-2095	4,220*
Limit warming to 2°C (>67%)	<ul style="list-style-type: none"> Pathways that limit warming to 2°C with a 67% probability with immediate action after 2020 	-63%	2020-2025	860 (2070-2075)
Limit warming to 2°C (>67%) or return warming to 1.5°C after a high overshoot, NDCs until 2030	<ul style="list-style-type: none"> GHG emissions until 2030 associated with the implementation of Nationally Determined Contributions (NDCs) announced prior to COP26, followed by accelerated emissions reductions <i>likely</i> to limit warming to 2°C or to return warming to 1.5°C with a probability of 50% or greater after high overshoot 	-75%	2020-2025	720 (2055-2060)
Limit warming to 1.5°C (>50%) with no or limited overshoot	<ul style="list-style-type: none"> Pathways limiting warming to 1.5°C with no or limited overshoot, assuming immediate action after 2020 	-84%	2020-2025	510 (2050-2055)

For reference, total anthropogenic CO₂ emissions 1990-2020 = ~1,000 gigatons

Note: * Net zero not achieved in these scenarios; figure represents net emissions 2020-2100

Source: IPCC, Sixth Assessment Report (AR6), *Climate Change 2022: Impacts, Adaptation and Vulnerability*, Summary for Policymakers, Figure SPM.4 (2022)



Chapter 3 Climate Action Tracker modeled pathways through 2100

APPENDIX

Annual global greenhouse gas emissions by pathway

(annual global GHG emissions, measured in billions of tons of CO₂-equivalent, historically and projected across various pathways)

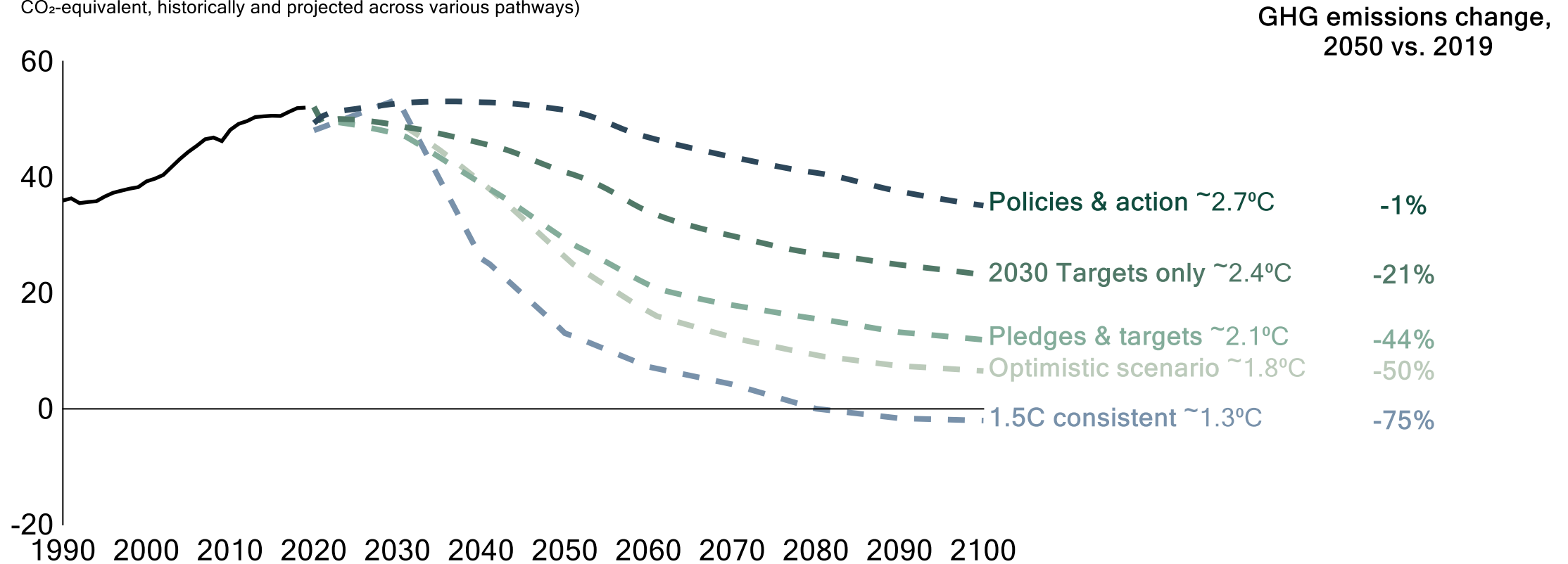

Source: Climate Action Tracker (as of Nov 2021)



Chapter 3 World Risk Index methodology

The WorldRiskIndex assesses the risk of disaster as a result of natural hazards. It incorporates both exposure and vulnerability and is used by the IPCC to gauge region- and country-level climate change risks

APPENDIX

World Risk Index

Exposure

Population exposed to...

1.0 ×

- Earthquakes
- Cyclones
- Floods

+

0.5 ×

- Droughts
- Sea level rise

÷ Country population

Source: IPCC AR6; WorldRiskReport 2021

Vulnerability

Calculated as: $\frac{1}{3} \times (\text{Susceptibility} + [1 - \text{Coping}] + [1 - \text{Adaptation}])$

Susceptibility		Coping		Adaptation	
0.29 ×	Public infrastructure Share of the population without access to basic sanitation services	0.45 ×	Government and authorities Corruption Perceptions Index	0.25 ×	Education and research Adult literacy rate
	Share of the population without access to basic drinking water services		Fragile States Index		Combined gross school enrollment
+		+		+	
0.29 ×	Housing conditions* Share of the population living in slums; proportion of semi-solid and fragile dwellings	0.45 ×	Disaster preparedness and early warning* National disaster risk management policy according to report to the United Nations	0.25 ×	Gender equality Gender inequality index
	Nutrition Share of the population that is undernourished		Medical services Number of physicians per 1,000 inhabitants		Environmental status/Ecosystem protection Water resources
+		+		+	
0.29 ×	Poverty and dependencies Dependency ratio (share of under 15- and over 65-year-olds in relation to working population)	0.1 ×	Number of hospital beds per 1,000 inhabitants	0.25 ×	Biodiversity and habitat protection
	Extreme poverty population living with USD 1.90 per day or less (purchasing power parity)		Social networks* Neighbors, family, and self-help		Forest management
+		+		+	
0.29 ×	Economic capacity and income distribution Gross domestic product per capita (purchasing power parity)	0.25 ×	Material coverage Insurance (life insurances excluded)	0.25 ×	Agricultural management
	Gini index		Adaptation strategies* Projects and strategies to adapt to natural hazards and climate change		Investment Public health expenditure
+		+		+	
				0.33 ×	
				0.33 ×	
				0.33 ×	



Chapter 3

Measuring historical CO₂ concentration levels

APPENDIX

800,000 BCE – 1950: Ice core record



Prehistoric CO₂ concentration is determined primarily by **measuring the composition of air trapped in ice cores** from Antarctica and Greenland. Each **deeper layer represents a slightly earlier** time in the Earth's climate history.

These ice-core measurements **agree with direct measurements from modern observatories.**

Source: NOAA; IPCC AR3, *The Carbon Cycle and Atmospheric Carbon Dioxide*

1950 – Today: Instrumental record



Direct measurements are taken from facilities like NOAA's **Mauna Loa Observatory** in Hawaii.

CO₂ mixes well throughout the atmosphere, so the trend at Mauna Loa is **statistically indistinguishable** from trends measured globally.



“SOLVING FOR THE DUAL CHALLENGE”