

Gas & Diesel Rotary Screw Compressor/Generator Compressor/Generator/Welder

Owner's Manual



Introduction: Congratulations on the purchase of your new air compressor. The air compressor is precision built from the finest materials using the finest state of the art design, and high tech engineering available today. Quality, performance and trouble free operation will assure you a dependable supply of air power on demand.

Check www.compressed-air-systems.com for most up to date manual and compressor service and technical information

CAUTION: Read this manual carefully before operating or servicing this air compressor, to familiarize yourself with the proper safety, operation, and standard operating procedures of this unit. **FAILURE TO COMPLY WITH INSTRUCTIONS IN THIS MANUAL COULD RESULT IN THE VOIDING OF YOUR WARRANTY, AND PERSONAL INJURY, AND/OR PROPERTY DAMAGE. THE MANUFACTURER OF THIS AIR COMPRESSOR WILL NOT BE LIABLE FOR ANY DAMAGE BECAUSE OF FAILURE TO FOLLOW THE INSTRUCTIONS IN THIS MANUAL.** By following the instructions and recommendations in this manual you will ensure a longer and safer service life of your air compressor.

NOTICE: All air compressors must be installed by a qualified and trained technician. If you need a qualified technician, call 800-531-9656 or 972-352-6304. Improper installation may result in damage to the compressor, personal injury, and will void the warranty of the compressor package.

If you have questions or need clarification about this manual or your compressor call 800-531-9656

Do not operate compressor outdoors in wet weather

Industrial Gold

Quality Air Compressors at a Great Price.

industrialgold.com ■ 1-800-531-9656 ■ Fax 972-352-6364

© Industrial Gold



Scan to visit our website



Contents

Additional Information..... 2
Safety Precautions and Warnings..... 3

Installation

Description of a Compressor..... 8
Receiving and Uncrating Your Compressor 10
Compressor Installation 11
Start-Up and Shut-Down Procedures 12

Maintenance

Stopping for Maintenance or Service 13
Maintenance Procedures Review 14
 Daily 14
 Weekly 14
 Monthly..... 14
 Every 3 Months/500 Hours 14
 Yearly/Every 2000 Hours 14
 Long Term Storage..... 14
Maintenance Log..... 15
Maintenance Procedures..... 16
Adjusting Belt Tension & Pulley Alignment 19
Self Tensioning Belt Rocker Plates..... 20

Other

Troubleshooting Common Issues 21
Notes..... 24
Warranty 26
Installation Sheet..... 27

Additional Information

For compressor pump information see pump specific manual.

For installation instructions see Install Guide.

For compressor package wiring diagram contact manufacturer.

For compressor parts breakdown see website (compressed-air-systems.com) or contact compressor manufacturer.

On electric driven compressors always follow NEC (National Electric Code) on any local applicable code that exceeds NEC guidelines.

On gas/diesel engine driven packages follow engine manufacturer guide for proper placement and installation of engine driven equipment.

NOTICE: Air compressors must be installed by trained installation personnel. Installation sheets must be sent back in for warranty activation. If you need help finding a qualified technician to properly perform installation, call 800-531-9656 or 972-352-6304.

WARNING: Read all installation steps in install guide, and compressor package manual prior to uncrating or installing compressor package. Failure to do so can result in personal injury or damage to compressor package.

NOTICE: All compressor air receivers should be inspected by a certified pressure vessel technician at least once per year, to check for leaks, weak points in the metal or any other deformity of the air receiver. If at any time a receiver appears out of conformance with ASME/CRN certification or a deformity is believed to have developed no matter how minor it may appear the tank should be locked out of service immediately and replaced with a certified ASME/CRN certified air receiver immediately before the compressor can be put back into service. The receivers should have a general inspection weekly as part of normal service.

SAFETY PRECAUTIONS AND WARNINGS

Listed are some, but not all safety precautions that must be observed with compressors and compressed air systems. Failure to follow any of these warnings may result in severe personal injury, death, property damage and/or compressor damage.

Air from this compressor will cause severe injury or death if used for breathing or food processing. Air used for these processes must meet OSHA 29 CFR 1910 or FDA 21 178.3570 regulations.

This compressor is designed for use in the compression of normal atmospheric air only. No other gases, vapors or fumes should be exposed to the compressor intake, nor processed through the compressor.

Disconnect all power supplies to the compressor plus any remote controllers prior to servicing the unit.

Relieve all pressure internal to the compressor prior to servicing.

Do not depend on check valves to hold system pressure.

A properly sized safety valve must be installed in the discharge piping ahead (upstream) of any shut-off valve (block valve), heat exchanger, orifice or any potential blockage point. Failure to install a safety relief valve could result in rupturing or explosion of some compressor or safety component.

Do not change the pressure setting of the safety relief valve, restrict the function of the safety relief valve, or replace the safety valve with a plug.

Over pressurization of some system or compressor component can occur, resulting in severe personal injury, death and property damage.

Never use plastic pipe, rubber hose, or soldered joints in any part of the compressed air system. Failure to ensure system compatibility with compressor piping is dangerously unsound.

Never use a flammable or toxic solvent for cleaning the air filter or any parts.

Do not attempt to service any part while the compressor is operating.

Do not operate the compressor at pressures in excess of its rating.

Do not remove any guards while the compressor is operating.

Observe gauges daily to ensure compressor is operating properly.

Follow all maintenance procedures and check all safety devices on schedule.

Compressed air is dangerous, do not play with it.

Use the correct lubricant at all times.

Always wear proper safety equipment when using compressed air.

Always install compressor to all local applicable electric codes.

WARNING: Always wear proper protective eye wear, hearing protection and safety clothing when working around the compressor package. No loose or baggy clothing should be worn around compressor package at any time.

WARNING: On Electric motor powered air compressors make sure electrical system is up to National Electric Code (NEC) prior to installing compressor system. Failure to install a compressor with a proper NEC electrical system can cause personal injury, compressor package damage and void compressor package warranty.

NOTICE: To ensure full compressor tank warranty all tank mounted compressor packages must be mounted on factory approved vibration isolation pads. A compressor should NEVER be installed while still on or in its original packaging. Failure to properly install the compressor system with approved vibration isolation pads will result in the compressor tank warranty being void.

WARNING: Industrial Gold compressors can operate at pressures from 0-250 PSI depending on the compressor package design and build specifications. Always verify that the system the compressor is installed into can handle the maximum operational pressure the compressor. NEVER install a compressor in a system that can not handle the compressors maximum operating pressure.

WARNING: Compressed air is extremely dangerous when not properly used or installed. Always make sure a trained compressed air professional has looked over the air system prior to use. Improper installation or use of compressed air can cause bodily injury or death. NEVER pressurize an object that was not designed to be pressurized. Pressurizing objects not properly engineered for the maximum operating pressure of the compressor system can cause bodily injury or death.

WARNING: Never apply air pressure to compressor crank case, always make sure crank case vent is clear and free from obstructions. Adding pressure to the crank case can cause serious bodily injury or death.

WARNING: Never operate a compressor in a moving vehicle or towable object in motion. Doing so can damage the compressor, compressor drive components, or auxiliary parts on the compressor package. Operating the compressor in a moving vehicle or towable object can cause serious bodily injury or death.

WARNING: Check function of safety valves, weekly to insure proper function, replace immediately if faulty or damaged.

WARNING: (Compressors Packaged with NEMA 7 Components)

Industrial Gold certifies that the electric motor, electrical enclosure and electrical conduit are rated for NEMA7/hazardous locations. (Only for applicable packages with NEMA7 added components)

Air compressors have multiple moving parts and potential points of contact that could create an ignition source. The compressor pumps are manufactured with ferrous metals and in some cases multiple moving parts can come in contact with one another causing an ignition source. Industrial Gold does not guarantee this will not occur. Lack of maintenance or care can result in conditions that could also cause ignition sources.

Industrial Gold only guarantees that the electric motor, electrical enclosure and electrical conduit are rated for NEMA7 hazardous location. Industrial Gold accept no other responsibility for the rating of the package.

NOISE

Noise is a potential health hazard that must be considered. There are local and federal laws specifying maximum acceptable noise levels that must not be exceeded. Most of the noise from a reciprocating compressor originates from the air inlet point. Excessive noise can be greatly reduced by installing an intake noise silencer. Intake noise silencers are available from the compressor manufacturer.

PIPING FITUP

Care must be taken to avoid assembling the piping in a strain with the compressor. It should line up without having to spring or twist into position. Adequate expansion loops or bends should be installed to prevent undue stresses at the compressor resulting from the changes between hot and cold conditions. Pipe support should be mounted independently of the compressor and anchored as necessary to limit vibration and prevent expansion strains.



Safety valves are to protect system integrity in accordance with ASME Codes and ANSI B19.3 safety standards. Failure to use safety valves of the proper capacity and pressure will cause severe personal injury or death.

NOTE: Standard motors are open drip proof with a maximum ambient temperature rating of 104°F. They are not suitable for salt laden, corrosive, dirty, wet, or explosive environments.

SAFETY VALVES: Safety valves are pressure relief valves and should be sized and purchased with a pressure setting to protect the weakest link in the system. Never change the pressure setting, only the safety valve manufacturer is qualified to make a change. Safety valves are to be placed ahead of any potential blockage point which includes but is not limited to, shutoff valves, heat exchangers, pulsation dampeners, and discharge silencers.



CAUTION

Failure to properly size, set and install pressure relief valves can be fatal.

Removal or painting over safety labels will result in uninformed conditions. This may result in personal injury or property damage. Warnings signs and labels must be provided with enough light to read, conspicuously located and maintained for legibility. Do not remove any warning, caution, or instructional material attached.

Provisions should be made to have the instruction manual readily available to the operator and maintenance personnel. If for any reason any part of the manual becomes illegible or if the manual is lost, have it replaced immediately. The instruction manual should be periodically read to refresh one's memory, it may prevent a serious or fatal accident.

NOTICE: Air compressors must be installed by trained installation personnel. Installation sheets must be sent back in for warranty activation. If you need help finding a qualified technician to properly perform installation, call 800-531-9656 or 972-352-6304.

	<p>ASME coded pressure vessels must not be modified, welded, repaired, reworked or subjected to operation conditions outside the nameplate ratings. Such actions will negate code status, effect insurance status and may cause severe personal injury, death, and property damage.</p>
--	---

PRESSURE VESSELS

Air receiver tanks and other pressure containing vessels such as, but not limited to, pulsation bottles, heat exchangers, moisture separators and traps, must be in accordance with ASME Boiler and Pressure Vessel Code Section VIII and ANSI B19.3 Safety Standards.

	<p>Relieve compressor and system air pressure by opening the appropriate manual relief valve prior to servicing.</p> <p>Failure to relieve all system pressure may result in severe personal injury, death and property damage.</p>
--	---

MANUAL RELIEF AND SHUTOFF VALVES

Install a manual relief valve to vent the compressor to atmosphere. In those instances where the air receiver tank services a single compressor, the manual relief valve can be installed on the receiver. When a manual shut-off valve, and a safety relief valve installed upstream from the manual relief valve. These valves are to be designed and installed as to permit maintenance to be performed in a safe manner. Never substitute a check valve for a manual shut-off valve (block valve) if the purpose is to isolate the compressor from a system for servicing.

	<p>Guards must be fastened in place before starting the compressor and never removed before cutting off and locking out the main power supply.</p>
--	--

GUARDS

All mechanical action or motion is hazardous in varying degrees and needs to be guarded. Guarding must be in compliance with OSHA Safety and Health Standards 29 CFR 1910.219 in OSHA manual 2206 and any state or local code.

	<p>Excessive speed of the compressor or driver can be lethal. Never operate the compressor beyond the manufacturer's recommendation.</p> <p>Bursting of the flywheel may be the greatest threat because the normal guard may not contain all the pieces.</p> <p>Crankshaft and connecting rod breakage is a possibility and compressor efficiency, valve life and bearing life will be abnormally reduced.</p>
--	--

DRIVES

It is important that the compressor and motor pulleys are aligned properly and the V belt is correctly tensioned. Improper pulley alignment and belt tension are causes for motor overloading, excessive vibration, and premature belt and/or bearing failure.



CAUTION

Generator System Information



CAUTION

Always allow generator to reach operating speed before connecting load

Always contact the factory before performing and repairs on generator

Never overload the generator overloading can and will damage generator

Never fuel engine will generator is running or plugged in

The generator is and electrical device and should never be operated in rainy or damp conditions severe electrocution can occur causing server injury or death

Never plug in frayed, damaged, exposed or broken wires or cords to generator sever electrical shock can occur

Only plug in approved UL or CSA devices

If the generator or package appears to be damaged do not operated and contact the factory for assistance

Do not modify or change the generator from its original state doing so can cause serious injury and void warranty

NOTICE: Air compressors must be installed by trained installation personnel. Installation sheets must be sent back in for warranty activation. If you need help finding a qualified technician to properly perform installation, call 800-531-9656 or 972-352-6304.

Description of Compressor

COMPRESSOR PACKAGE

This Industrial Gold industrial rotary screw compressor is an electric motor driven single stage helical rotary screw compressor. It is sold as a complete package mounted on a steel base. This unit can come with options of being tank mounted, enclosure mounted or enclosure tank mounted.

The package includes the compressor air end, electric motor, motor controls, air intake system, cooling system, SMART contact capacity control system, air/oil separator, and instrumentation. Installation requires only electric power and a service line.

This air compressor is a rotating piece of equipment and should not be worked on or serviced while there is power to the unit. You should always turn the power off to the compressor unit before performing any kind of service to the machine.

If you have any questions, please contact the manufacturer for clarifications before making any changes to the delivered state of the compressor.

COMPRESSOR

The compressor assembly is a positive displacement, oil flood lubricated, helical rotary screw type unit employing a single stage of compression. The components include housing or stator, two rotors or screws, bearings and bearing supports.

In operation, two helical grooved rotors mesh to compress air. Inlet air entering the compressor becomes trapped between the lobes of the rotors. As the rotors turn, this trapped volume of air is reduced in volume or compressed and is pushed to the discharge end of the compressor. This process delivers smooth flowing air at full pressure to the receiver.

During the compression cycle, oil is injected into the compressor for the purposes of lubricating, cooling, and sealing. Compressed air laden with oil leaves the compressor through a discharge port designed to provide optimum performance within the desired pressure range.

AIR/OIL SYSTEM

The air/oil system is almost completely contained within the compressor housing. Within or directly attached to the housing are the air filter, oil filter and the air/oil separator element.

AIR FILTER

The air filter is a high efficiency ring style located on top of the inlet valve of the compressor. It will provide nearly constant efficiency of filtration at all load conditions. The element has a high dirt holding capacity for a long life. It is specially treated to be insensitive to heat, cold, water, and oil.

OIL FILTER

The oil filter is a 10-micron spin-on style. It is sized to maintain system cleanliness and to give good service life. The housing is equipped with a bypass to ensure that there is oil flow on startup. The restriction created at the filter will have a direct effect on the operating temperature of the compressor. So you must be sure to maintain it.

AIR/OIL SEPARATOR

This unit utilizes a spin-on air/oil separator to make maintenance much more convenient than the element in vessel design. This does not diminish its operating efficiency. In fact, the separation of the element from the pre-separation tank enhances the performance. The purpose of the separator is to remove aerosols. The vapor pressure of the oil, the operating temperature of the unit, operating pressure of the unit and the operating cycle will affect its performance.

The owner, leaser, or operator of this compressor is hereby notified and forewarned that any failure to observe these safety precautions in this manual may result in injury, damage to the unit or death.

Industrial Gold expressly disclaims responsibility or liability for any injury or damage caused by failure to follow these specified precautions or by failure to exercise the ordinary caution and due care required in operation or handling the compressor even though not expressly specified here.

If you have any questions, contact the manufacturer immediately at 1-800-531-9656.

NOTICE: Air compressors must be installed by trained installation personnel. Installation sheets must be sent back in for warranty activation. If you need help finding a qualified technician to properly perform installation, call 800-531-9656 or 972-352-6304.

MINIMUM PRESSURE VALVE

As the compressed air leaves the compressor, it goes through a minimum pressure valve. This is set to maintain at least 85 PSIG (586kPa) in the sump when the compressor is running. This is to ensure that there is pressure to force the oil out of the sump and through the oil system so that sufficient oil is injected into the compressor. It is also necessary to provide good air/oil separation. The valve acts as a check valve to prevent back flow into the compressor from the plant system.

COOLING

The compressor has an air-cooled and after-cooler as standard. Below are the heat loads and cooling airflow rates that must be accommodated.

The compressor is an oil flooded unit. The oil lubricates, seals, and cools the internals of the compressor.

In cooling, it picks up the heat generated by the compression process and the mechanical friction from the bearings. So the oil must be cooled to within 60° F of the ambient temperature.

The after-cooler has been designed for a minimum approach of 15°F.

CONTROLS

The RS series of units is equipped with a normally closed inlet valve. This means that when the unit is started, the inlet valve remains closed while the unit builds up pressure by means of a bypass line. After startup the inlet valve is controlled by a simple on/off action of a pressure switch working with a solenoid valve.

For instrumentation, the unit has a discharge temperature gauge, and air pressure gauge.



Inlet containing reactive gases will cause the failure of the lubricant and compressor.

Ensure an air supply that is well clear of any reactive gas source.

If it is necessary to take air from a remote source, the piping should be at least the diameter of the air filter inlet. For distance over twenty feet the diameter needs to be enlarged to reduce the restriction. This pipe should also be corrosion resistant and free from scale and dirt. The inlet should also be covered to prevent rain and small animals from entering.

HEAT LOAD OF COMPRESSOR

MODEL	TOTAL HEAT LOAD B/Min	REQUIRED FLOW CFM
5-7.5HP	805	1767
10HP	1064	2335
15HP	1587	3483
20HP	2104	4619
25HP	2727	5985
30HP	3250	7134
40HP	4256	9341
50HP	5325	11,700
60HP	6390	14,040
75HP	7988	17,550
100HP	10,650	23,400
125HP	13,313	29,250
150HP	15,975	35,100
200HP	21,300	46,800
250HP	26,625	58,500
300HP	31,950	70,200

Receiving and Uncrating of your Compressor

BEFORE UNCRATING THE COMPRESSOR THE FOLLOWING STEPS SHOULD BE TAKEN.

1. Immediately upon receipt of the equipment, it should be inspected for damage that may have occurred during shipment. If any damage is found, demand an inspection immediately by an inspector from the carrier. Ask them how to file a claim for damages.
2. Ensure that adequate lifting equipment is available for moving the machinery. Never attempt to move compressor without proper lifting equipment.
3. Read the compressor nameplate to be sure the compressor is the model and size ordered.
4. Read the motor nameplate to be sure the motor is compatible with your electrical conditions.

IMPORTANT: Compressor drive engine comes with its own manual refer to drive engine manual for any specifications or troubleshooting issues with the drive engine of the air compressor



CAUTION

Improper lifting can result in component or system damage or personal injury.

Follow good shop practices and safety procedures



CAUTION

Under no circumstances should a compressor be placed in an area that may be exposed to a flammable, toxic, volatile or corrosive atmosphere nor should flammable, toxic, volatile or corrosive agents be stored near the compressor.

NOTICE: Air compressors must be installed by trained installation personnel. Installation sheets must be sent back in for warranty activation. If you need help finding a qualified technician to properly perform installation, call 800-531-9656 or 972-352-6304.

Compressor Installation

LOCATION

Locate the compressor in an area that is clean, dry, well lighted, and well ventilated, with sufficient space for safe and proper inspection and maintenance. Ambient temperatures should not exceed 110°F or fall below 30°F unless a motor rated for a higher temperature is used. Inspection and maintenance checks are required daily, therefore, ample space is required around the compressor.

The compressor must not be installed closer than 24 inches from a wall or other solid structure to allow ample circulation of air across the compressor cylinders and head, and through the coolers if they are part of the system. Additional safety can be achieved by locating the pulley guard next to the wall or solid structure.

MOUNTING

The use of the factory supplied rubber vibration isolation pads, or other factory supplied vibration isolation mounting equipment is required for tank warranty from the original tank manufacturer. The compressor should never be left on original shipping material for installation. If a shim is required to level the unit, place it between the pad and floor. If you bolt the unit to the floor, use the bolts as guide pins and do not tighten the bolts. The rubber pads are used to absorb machine vibration and cannot work effectively if bolted tightly.

INDUCTION SYSTEM

Do not locate the compressor where it could ingest or ignite toxic, explosive or corrosive vapors, ambient air temperatures exceeding 110°F, water or extremely dirty air. Ingestion of any of the above noted atmospheres by the compressor could jeopardize the performance of the equipment and all personnel exposed to the total compressed air system.

AIR INTAKE

To achieve the longest filter and lubricant life and the least maintenance you need to supply the compressor with the cleanest air possible. It must not contain any flammable or toxic gases. These will be concentrated by the compressor, and could result in personal injury or death and property damage.

STORAGE

In some cases it may be necessary to store the compressor for extended periods of several months before placing the unit in operation. When this is required do the following:

Cover and seal all machine openings to prevent the entrance of water and dirt.

Cover all openings in open drip proof motors to prevent the entrance of rodents.

If the storage conditions are below freezing; drain the after cooler, traps, water-cooled heat exchanges and attendant piping. We do not recommend outside storage.

Cover with a waterproof tarpaulin that can easily be removed for in-storage maintenance.

While in storage, every two or three months, rotate the compressor and motor by hand to prevent flat spots on the bearings that will lead to premature failure.

At the end of the storage period, follow the uncrating and start-up procedures. If the unit has been stored for more than eighteen months, you should contact Industrial Gold before restarting the compressor.

For compressor tank to have full manufacturer warranty. The tank must be installed properly on manufacturer supplied vibration pads per compressor manual. Failure to do so can void compressor tank warranty and cause tank cracks or failures.

Initial Start-Up

Every Industrial Gold compressor has been operated and thoroughly tested at the factory prior to shipment. The test ensures that the compressor will deliver its rated capacity and is in good working order.

However, there is the possibility that damage may occur in shipping. For this reason, it is recommended that the unit be carefully inspected for evidence of damage or malfunction before installation and during the first hours of operation.

PREPARATION FOR INITIAL START-UP

1. Review the installation instructions to see that everything is complete.
2. Inspect for visible signs of damage that could have happened during shipment or installation.
3. Make certain protective coverings required for shipment or painting are removed from the compressor.
4. Fill the sump to the proper oil level. Do not overfill. If it is, drain to proper level. Tighten the fill cap securely.
5. Start the unit and run for several minutes, then shutdown. Check the oil level and add, if necessary, to compensate for filling the system.
6. Begin normal operation.

Normal Operation

DAILY START-UP

1. Drain off condensate from the sump and check the oil level. Refill as necessary.
2. Check for any oil leaks. Correct as necessary.
3. On water cooled units, turn on the water.
4. Ensure the engine fuel tank is filled with proper fuel according to engine manual.
5. When starting cold, drain tank pressure below 10 PSI.
6. Put Unloader lever on Pilot Valve to Unloaded position.
7. Put choke lever in position according to ambient temperature conditions.
8. Pull start units: move ON/OFF switch to ON position.
Electric start units: turn key to ON position.
9. Pull start units: pull start cord to start engine.
Electric start units: turn key to START position. Once started return key to ON position.
10. Let compressor run for 15 seconds unloaded.
11. Turn Load/Unload switch to Load position.

STOPPING

1. Turn Load/Unload switch to Unloaded position. Make sure the compressor is fully unloaded before Step 2.
2. Turn run switch to OFF position

NOTICE: Air compressors must be installed by trained installation personnel. Installation sheets must be sent back in for warranty activation. If you need help finding a qualified technician to properly perform installation, call 800-531-9656 or 972-352-6304.

Stopping for Maintenance or Service

	<p>Never assume the compressor is ready for maintenance or service because it is stopped.</p> <p>The automatic stop-start control may start the compressor at any time!</p>
---	---

The following procedure should be followed to maximize safety when preparing for maintenance or service.

1. Turn compressor drive engine key switch off and remove key from compressor.
2. Close shut-off valve (block or ball valve) between compressor and main supply (air tank or air lines). This is the valve installed to isolate the air compressor for maintenance or service. The valve is placed in the system during installation for the purpose of servicing the compressor and to not allow (shop or working) air back into the compressor during service. *See note for turning compressor off while under a load or compressing air.
3. Lock open manual vent valve and wait for the pressure in the area to be serviced (compressor, receiver, etc.) to be completely relieved before starting service. The Manual vent valve may be the drain valve in the receiver. NEVER remove a plug to relieve the pressure
4. Disconnect battery connection to compressor drive engine
5. Lock open manual vent valve and wait for the pressure in the area to be serviced (compressor, receiver, etc.) to be completely relieved before starting service. The Manual vent valve may be the drain valve in the receiver. NEVER remove a plug to relieve the pressure.
6. Open all manual drain valves within the area to be serviced.
7. Wait for the unit to cool before starting service, (temperatures at 125 degrees F can burn the skin), some surface temperatures exceed 400 °F when the compressor is working).
8. Clean up all oils spills immediately to prevent slipping.

* Note. If the compressor is turned off before being fully unloaded it can cause the unit to discharge oil into the air filter housing and could cause the air filter element to become contaminated. This may happen when using the emergency shut-off button and/or the on/off switch

Maintenance Procedures Review

DAILY:

- Check airend oil level - remove oil fill cap and check for proper level.
- Drain the receiver - condensation will accumulate in the tank daily, and should be drained at least once a day. This is done to reduce corrosions of the tank from the inside. Always wear protective eye wear when draining the tank.
- Check oil cooler - check cooler for proper air flow to keep unit cool, and clean if necessary
- Check unit for any unusual noise or vibrations.

WEEKLY:

- Clean air filter - this will ensure that no dirt or heavy particulate makes its way into the compressors valve assemblies.
- Clean external parts of compressor and electric motor - this helps to ensure proper cooling and prevents rust and corrosion on critical parts.
- Check safety valves - this is done to ensure they are not stuck in place and operating properly.
- Check belts - turn off the compressor and inspect the belts for damage, excessive wear, and correct tension. Replace if necessary.
- Inspect compressor intake - never use gasoline, thinners or other flammable solutions to clean valves or related parts.
- Check to be sure the valves are seated against the sealing surface around each port. If the valves are not sealing, compressor capacity will be severely reduced.

MONTHLY:

- Inspect complete air system for leaks - this is done to make sure the compressor does not get out of its duty cycle due to air leaks in the system.
- Inspect oil for contamination - this is done to ensure that harmful deposits do not build up in the oil.
- Check belt tension - this is done to ensure the belt does not fail pre-maturely, tighten them as needed to ensure they do not slip. If belts are loose, tighten per instructions on next page. Failure to tighten can cause pre-mature belt failure.

EVERY 3 MONTHS OR 500 HOURS

(WHICHEVER COMES FIRST):

- Change oil filter - this is done to ensure that the compressor has proper oil level and that the oil in the machine does not deteriorate past factory specifications
- Check airend filter - change as needed.

YEARLY OR EVERY 2000 HOURS

(WHICHEVER COMES FIRST):

- Change oil - change with only CAS RS8000, or other factory approved lubricants.
- Clean oil cooler - this is done to ensure adequate cooling for the compressor air end.

LONG TERM STORAGE PROCEDURES:

(COMPRESSORS THAT WILL NOT BE USED FOR 60 DAYS OR MORE)

1. **Electric Powered Units-** Turn off power and disconnect power from main compressor disconnect panel.
Gas/Diesel/Natural Gas Powered Units- Drain any fuel from package/disconnect any fuel source from system.
2. Drain compressor oil and change filters, refill oil. If engine driven drain engine oil, change filters, refill with oil.
3. Check compressor intake for debris, clean out if needed (Cover compressor intake to prevent debris, insects, etc. from entering compressor intake).
4. Clean off compressor package.
5. Drain all moisture from air compressor tank.
6. Cover compressor to prevent debris from collecting on compressor and store in a location out of direct sunlight/rain/weather. Do not seal compressor cover as moisture may form and prematurely rust parts due to humidity not being able to escape.
7. If storage last 90 days or more every 30 days, manually rotate compressor pump/airend 1/4 turn.
8. Before putting compressor back into operation drain oil, change all filters, and check belt tension if belt driven. If compressor stored longer than 120 days inspect compressor intake and discharge valves on reciprocating, intake and MPV valve on rotary screws. If reciprocating check compressor check valve for operation.
9. Follow install guide and proper start up procedures prior to putting air compressor back into service. (Fill out a new compressor install data sheet at time of re-installation or initial installation).

Rotary Screw Compressor Maintenance Log

MAINTENANCE TO BE PREFORMED EVERY 3 MONTHS OR 500 HOURS (WHICHEVER COMES FIRST)
AND EVERY YEAR OR 2000 HOURS (WHICH EVER COMES FIRST)

DATE PUT INTO SERVICE:									
SERVICE INTERVALS	TECH'S INITIALS	DATE	Quarterly					Yearly	
			CHANGE		INSPECT	CLEAN		CHANGE	
			OIL FILTER	AIR FILTER	BELT IF EQUIPPED	TANK DRAIN	AIR/OIL COOLER	SEPARATOR	OIL IAT-RS8000
Q1								—	—
Q2								—	—
Q3								—	—
Q4									
Q5								—	—
Q6								—	—
Q7								—	—
Q8									
Q9								—	—
Q10								—	—
Q11								—	—
Q12									
Q13								—	—
Q14								—	—
Q15								—	—
Q16									

- Service intervals are based on operating no more than 5 days per week 8 hours per day at 50% duty cycle.
- Increase frequency if operated more than above recommendations.
- Refer to owners manual prior to performing maintenance and for service item part numbers.
- Failure to perform recommended maintenance may cause damage to compressor and void warranty.

Maintenance Procedures



Hot oil under pressure will cause severe injury, death, or property damage.
Be sure the compressor is shutdown and pressure relieved before attempting to remove the oil filter, separator, oil fill, or change the oil.

AIR FILTER

The air filter is the primary protection of the compressor from harmful dirt being ingested into the oil system. It needs to be looked at periodically for clogging or holes. The period for these inspections is dependent on the environment the machine is in.

For optimum life, it is recommended that an air filter restriction indicator be used. Service simply based on hours is not recommended.

AIR FILTER INSPECTION AND REPLACEMENT

1. Switch off the unit and disconnect the power to prevent accidental starting.
2. Allow one minute after stopping for the system to settle and the pressure to be relieved.
3. Loosen the nut that secures the cover and remove the cover.
4. Remove the element.
5. Place a bright light inside the element to inspect for damage or leak holes.
6. Inspect all gaskets and gasket contact surfaces of the housing. Correct any faulty conditions immediately.
7. Clean the housing with a damp cloth. Do not attempt to blow out dirt with compressed air.
8. Place a new element in the housing.
9. Replace the cover and tighten the nut.
10. Reset the filter indicator and the machine will be ready for operation.

If the compressor is turned off before being fully unloaded, it can cause the unit to discharge oil into the air filter housing causing it to stop up or become contaminated.

OIL FILTER

The oil filter in the compressor system is a full flow replaceable canister type. This element protects the compressor bearings from grit and dirt ingress throughout the system. A dirty filter will cause an oil flow restriction that can result in high oil temperature and a unit shutdown.

OIL FILTER REPLACEMENT

1. Switch off the unit and disconnect the power to prevent accidental starting.
2. Allow one minute after stopping for the system to settle and the pressure to be relieved.
3. Using a strap wrench, remove the old element and gasket.
4. Clean the gasket surface with a clean rag.
5. Apply a light film of oil to the new gasket.
6. Hand tighten the new element until the new gasket is seated in the gasket groove.
7. Continue to tighten by hand an additional $\frac{1}{2}$ to $\frac{3}{4}$ turn.
8. Reconnect power and restart the machine to check for leaks.

NOTICE: Air compressors must be installed by trained installation personnel. Installation sheets must be sent back in for warranty activation. If you need help finding a qualified technician to properly perform installation, call 800-531-9656 or 972-352-6304.

Maintenance Procedures Continued



Hot oil under pressure will cause severe injury, death, or property damage.
Be sure the compressor is shutdown and pressure relieved before attempting to remove the oil filter, separator, oil fill, or change the oil.

AIR/OIL SEPARATOR

The air/oil separator should be changed every 2000 hours, or when there is excessive oil vapor in the discharge air.

SEPARATOR ELEMENT REPLACEMENT

1. Switch off the unit and disconnect the power to prevent accidental starting.
2. Allow one minute after stopping for the system to settle and the pressure to be relieved.
3. Using a strap wrench, remove the old element and gasket.
4. Clean the gasket surface with a clean rag.
5. Apply a light film of oil to the new gasket.
6. Hand tighten the new element until the new gasket is seated in the gasket groove.
7. Continue tightening by hand and additional $\frac{1}{2}$ to $\frac{3}{4}$ turn.
8. Reconnect power and restart the machine to check for leaks.

OIL ANALYSIS

Oil analysis is an excellent tool to add to your compressor maintenance program. At regular intervals you submit lubricant samples to a qualified laboratory. From this you receive a detailed report showing the lubricant condition, wear metals, and contaminants. Changes in this information over time provides the basis for predictive compressor maintenance, saving you unplanned machine downtime and unnecessary oil changes.

OIL RETURN SIGHT GLASS

During loaded operation there should be a visible flow in the sight glass. If there are no droplets visible then the orifice in this line needs to be checked. Oil not returned ends up in the plant air system.

CHECKING OIL LEVEL AND ADDING COMPRESSOR OIL

1. Switch off the unit and disconnect the power to prevent accidental restarting.
2. Allow one minute after stopping the compressor for settling and the pressure to relieve.
3. Remove any dirt from around the fill cap, then remove the fill cap.
4. Inspect the o-ring in the cap for damage and cleanliness. Replace if necessary.
5. The oil should be between the bottom of the neck and the o-ring groove or $\frac{1}{2}$ full in sight glass.
6. Replace the cap securely. Never put the cap on without tightening immediately.

TO CHECK THE BELTS

1. Switch off the unit and disconnect the power.
2. Allow one minute after stopping the compressor for settling and the pressure to relieve.
3. Remove the belt guard.
4. Inspect for any fraying or cracking of the belts. If there is any, replace the belts.
5. Check the tension. It should be about $\frac{1}{64}$ " per inch of span between the sheaves

TO CHANGE THE BELTS

1. Switch off the unit and disconnect the power.
2. Allow one minute after stopping the compressor for settling and the pressure to relieve.
3. Remove the belt guard.
4. Loosen the motor hold down bolts and the puller bolt and slide the motor toward the air end.
5. Remove the belt.
6. Replace with new belt.
7. Set the initial by sliding the motor back to its original position using the puller bolt and tighten the motor hold down bolts.

Maintenance Procedures Continued

LUBRICANT

Your compressor has been filled and tested with CAS RS8000, a high quality compressor lubricant. It is a PAO with the advantage of extended service life, high temperature operation, easy start-up when cold, reduced sludge and lacquer buildup, and is completely compatible with all seals, gaskets, and other compressor materials.

LUBRICANT SPECIFICATIONS

If you choose not to use CAS RS8000, for optimum life and warranty service your lubricant must meet the following specification:

Grade ISO.....	46
Viscosity@100°F, CST	46
Viscosity@210°F,CST	7.93
Viscosity Index.....	100 or more
Pour Point,°F.....	-20° or less
Flash Point, °F.....	400° or more
Fire Point, °F.....	450° or more
Rust Test ASTM-FG-665 A&B.....	Pass
Oxidation Test, ASTM0-D943.....	1500
Emulsion Test, ASTM-D1401	10 Min.
Foam Test, ASTM.....	Pass

CHANGING COMPRESSOR LUBRICANT

Regular maintenance of the oil filter and the air filter will help prolong the life of the lubricant.

1. Switch off the unit and disconnect the power to prevent accidental restarting.
2. Allow one minute after stopping the compressor for settling and the pressure to relieve.
3. Remove any dirt from around the fill cap, and then remove the fill cap. If the lubricant appears dirty or has a foul smell, it should be replaced.
4. Drain the lubricant from the bottom of the air/oil receiver. Oil will drain more quickly and completely if is warm from operation.
5. Close all drains and replace with fresh CAS RS8000 to the proper level.
6. Replace the fill cap and run the unit.
7. Switch off the unit and disconnect the power
8. Allow one minute after stopping the compressor for settling and the pressure to relieve.
9. Remove the fill cap to see if more lubricant should be added and to ensure that there are no leaks.

MINIMUM PRESSURE VALVE

Then minimum pressure valve is a non-adjustable spring biased check valve. It has been designed to maintain a minimum sump pressure of 85 psig.

If the pressure is allowed to get too low, the oil carryover rate will increase and the separator could be damaged.

FAN

Check the fan for cracking, loose rivets, and bent or loose blades. Make sure that it is securely mounted and tighten the mounting screws if loose. Replace a damaged fan immediately.

Common Maintenance Parts

ROTARY SCREW COMPRESSOR CONSUMABLES	AIR FILTER	OIL FILTER	SEPERATOR	OIL CAPACITY (GALLONS)
RS3	IAT-AF7	IAT-OF1	IAT-SE-1	1
RS3 Cube	IAT-AF7	IAT-OF1	IAT-SE-2	1
RS6	IAT-AF8	IAT-OF5	IAT-SE-4	2.5
RS8	IAT-GCU55-AF	IAT-OF5	IAT-GCU55-SEP	5

NOTICE: Air compressors must be installed by trained installation personnel. Installation sheets must be sent back in for warranty activation. If you need help finding a qualified technician to properly perform installation, call **800-531-9656** or **972-352-6304**.

Adjusting Belt Tension

Proper belt tension and pulley alignment must be maintained for maximum drive efficiency and for maximum belt life. The correct tensions exists if a deflection of ½ inch occurs by placing 10lbs of force midway between the motor pulley and the compressor flywheel. This deflection can be adjusted by the following procedure. The pulley should be carefully aligned with the flywheel and set screws should be kept tight.

1. Remove the belt guard
2. Loosen the motor mounting bolts
3. Shift the motor to the point where the correct deflection exists
4. Retighten the motor mounting bolts
5. Check to ensure that the tension remain correct after tightening
6. Re-install the belt guard. All moving parts must be guarded

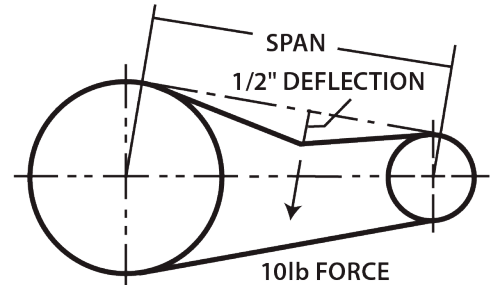

NOTE: Drive belt tension and pulley alignment are done at the same time. They are discussed separately for clarity.

Pulley Alignment

The figure to the side shows 3 examples of misaligned pulleys. To check pulley alignment, remove the belt guard and place a straightedge against the compressor flywheel, measure and record the distance from the straightedge to the edge of the drive belt. Then measure the distance to the edge of the drive belt on the motor pulley at the same edge. As long as both points measure the same distance the pulleys will be aligned if not you will need to move the pulley until it's in alignment. This may take a few tries. To realign the pulley follow the steps below

1. Loosen the motor mounting bolts
2. Remove the belt guard
3. Loosen the set screw on the motor pulley
4. Align the motor pulley with the compressor flywheel
5. Re-tighten the motor pulley set screws
6. Adjust the proper belt tension
7. Re-tighten the motor mounting bolts
8. Re-install the belt guard

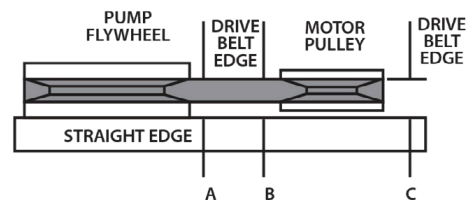
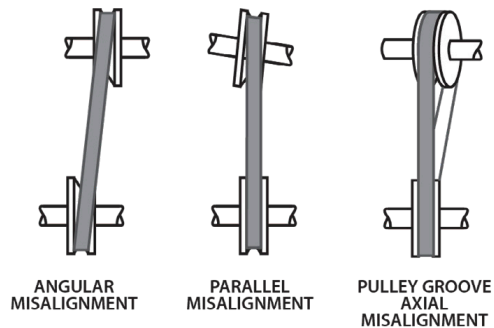

NOTICE: Air compressors must be installed by trained installation personnel. Installation sheets must be sent back in for warranty activation. If you need help finding a qualified technician to properly perform installation, call 800-531-9656 or 972-352-6304.

Illustration A

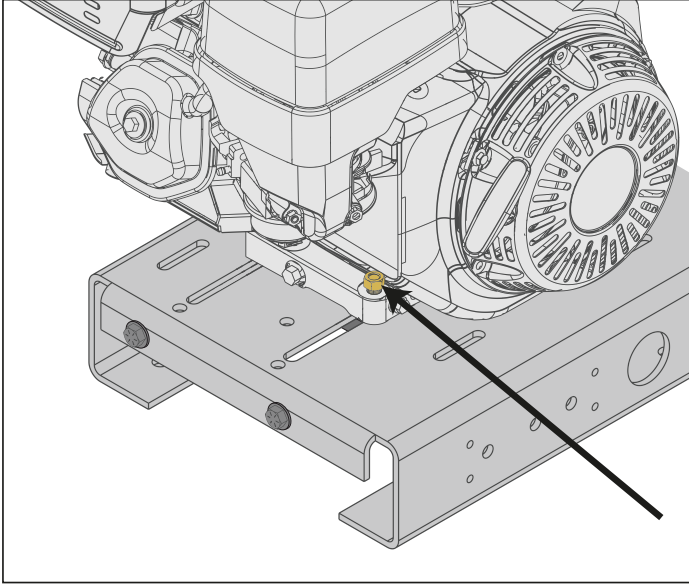
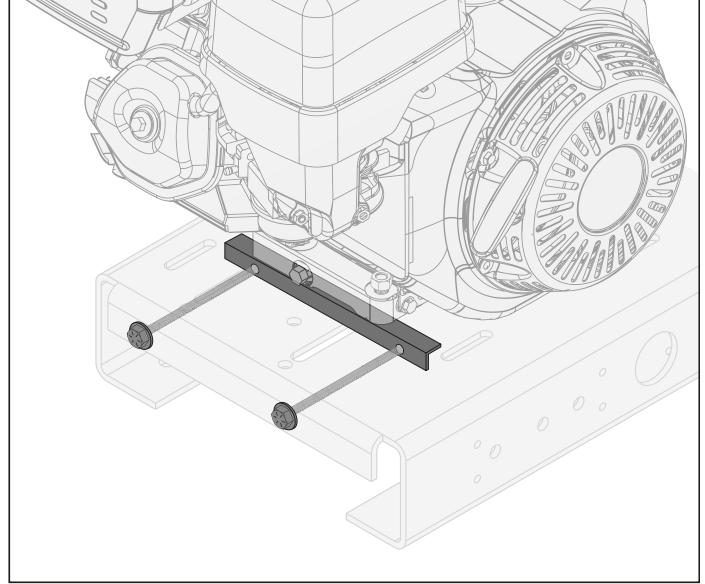

Illustration B



Belt Tensioning System for Engine Driven Units

Some engine driven units are equipped with an adjustable belt tension system. Proper belt tension is critical to performance and reliability. Follow the steps below to make adjustments:

1. Loosen the four bolts that secure the engine to the baseplate, highlighted in Illustration A. This will allow the engine to move during adjustment.
2. Use the adjustment bolts shown in Illustration B to adjust belt tension.
 - To tighten the belt, turn the bolts clockwise. To loosen, turn them counter-clockwise.
 - Alternate between the adjustment bolts. Never crank one side all at once. Turn each bolt only one full rotation at a time.
 - Continue adjusting until the belt has the proper deflection. (Refer to the Adjusting Belt Tension section of this manual for correct specifications.)
3. Once proper tension is reached, retighten the four engine mounting bolts firmly to lock the engine in position.

Troubleshooting Chart

NOTE: TROUBLESHOOTING PROBLEMS MAY HAVE SIMILAR CAUSES AND SOLUTIONS

You should always contact an authorized service center before attempting to fix or repair your air compressor.

Make sure drive engine battery is disconnected before any maintenance or repair.

Always make sure compressor drive engine key switch is off and removed from the compressor.

Problem	Possible causes	Solutions
Compressor Stalls and Dies	Drive engine low on fuel Compressor check valve not functioning Compressor Pilot valve not functioning Spark Plug in Engine bad Drive engine Low on oil	Check fuel level in drive engine Inspect compressor check valve Check drive engine spark plug Check oil level on compressor drive engine Check oil on compressor pump
Compressor is running and is not compressing air	Compressor Pilot valve is actuated Compressor pilot valve is malfunctioning Compressors pump head unloaders stuck engaged	Check pilot valve to make sure it in the proper position Replace compressor pilot valve Check and clean compressor pump head unloaders
Compressor does not idle up for Compression	Throttle control valve (bullwhip) not engaging Throttle control valve cable broken Drive engine throttle linkage damaged	Check throttle control valve (bullwhip) for proper function Replace throttle control valve Check drive engine throttle linkage
Compressor Airend bogs down while compressing air	Loose motor pulley or Compressor belts loose Compressor pulley worn	Check belts for wear Check pulley for wear

Troubleshooting Chart (continued)

NOTE: TROUBLESHOOTING PROBLEMS MAY HAVE SIMILAR CAUSES AND SOLUTIONS

You should always contact an authorized service center before attempting to fix or repair your air compressor.

Make sure drive engine battery is disconnected before any maintenance or repair.

Always make sure compressor drive engine key switch is off and removed from the compressor.

Problem	Possible causes	Solutions
Excessive oil discharge in air (All Compressors have a small amount of oil carry over in compression)	Worn piston rings or cylinder Restricted air intake Oil level too high Compressor has exceeded its duty cycle	Clean or replace air filters Reduce oil level to recommended amount Reduce compressor duty cycle (repair leaks or add another unit to handle the excess demand)
Compressor Overheating	Poor ventilation Dirty cooling surfaces Compressor is out of its operating duty cycle	Relocate compressor to any area with better ventilation (at least 18 inches from the nearest wall) Clean all cooling surfaces Reduce compressor duty cycle (repair leaks or add another unit to handle the excess demand)
Excessive Belt Wear	Pulley out of alignment Improper belt tension Pulley damaged or loose	Realign pulley with flywheel Re-adjust belt tension
Compressor won't start in Cold weather	Bad check valve Compressor has wrong grade oil Control lines frozen	Use IS 100 (30W) compressor oil for cold weather conditions Move compressor to a warmer location Put a heat lamp on compressor to maintain above freezing temperatures
Compressor Has Excessive vibration	Compressor is not properly mounted on vibration isolation pads Compressor pulley is out of alignment Engine is low on fuel or throttle is out of adjustment	Properly mount compressor on vibration isolation pads Re-align pulleys Check drive engine oil and fuel level Re-adjust engine throttle control (bull whip)

Troubleshooting Chart Generator

NOTE: TROUBLESHOOTING PROBLEMS MAY HAVE SIMILAR CAUSES AND SOLUTIONS

You should always contact an authorized service center before attempting to fix or repair your air compressor.

Make sure drive engine battery is disconnected before any maintenance or repair.

Always make sure compressor drive engine key switch is off and removed from the compressor.

Problem	Possible causes	Solutions
Voltage Low	Engine Speed to low Generator overloaded	Replace or repair engine throttle device Reduce load on generator by unplugging components
Circuit Breaker Trips	Defective load connected to generator Defective receptacle Generator overloaded	Disconnect load Replace receptacle Reduce load on generator
Voltage Too High	Drive engine speed to high	Reduce drive engine speed
Generator is over-heating	Generator is overloaded Insufficient ventilation	Reduce load on generator Make sure adequate air flow to generator and engine
No voltage output	Defective load connected Broken or loose wire Defective receptacle Defective stator Defective rotor Defective capacitor Circuit breaker tripped	Disconnect load 2-6 Have generator checked out by authorized generator technician Reset circuit breaker

Certificate of Limited Warranty Reciprocating Compressors and Parts

All component parts on this compressor, installed by the manufacturer, are warranted to be free of defects in workmanship and material for a period of one year. Transportation charges are the responsibility of the purchaser. This warranty extends to the original purchaser of the compressor only. The purchaser must use Synthetic Reciprocating Compressor Oil, Part Number 30100, in the compressor for the duration of the compressor warranty. There are NO express warranties other than those contained in this limited warranty statement. Covered in the one year period of the warranty are defective parts and labor only. Part defects are limited to original parts only. The compressor warranty is void in the case of abuse, lack of proper service, incorrect application, incorrect installation, and neglect. Industrial Electric stationary compressors may be repaired on site as long as the compressor is not located further than 50 miles from the service center. The purchaser is responsible for any additional travel expense beyond 50 miles from the service center. Gas/Diesel Engine Driven, Single Stage Stationary, and Contractor Series compressors must be repaired at the closest service center to the compressor. The purchaser is responsible for any travel expense if they do not wish to bring the compressor to the service center. ALL "SPECIALTY COMPRESSOR" WARRANTY SERVICE MUST BE PERFORMED AT THE CLOSEST SERVICE CENTER TO THE COMPRESSOR. A "SPECIALTY COMPRESSOR" is any compressor packaged with options other than those that apply to the standard models in the catalog. Warranty labor for the first year is only covered for work performed Monday-Friday 8am-5pm excluding all major US holidays. BEFORE WARRANTY SERVICE IS PERFORMED, CONTACT THE MANUFACTURER TECH SUPPORT FOR FASTEST SOLUTION AND APPROVAL (800-531-9656 or 972-352-6304). Warranty repairs must be authorized by the manufacturer prior to work being performed. Unauthorized work may void the package warranty. The warranty claim form MUST be submitted for any potential warranty claim to be reviewed. A copy of the original invoice must be sent in with the warranty claim form.

The limited warranty is not active until the installation sheet, included with the compressor manual, is properly filled out and returned. Failure to return the installation sheet will prevent the warranty from being active.

Certificate of Limited Warranty Parts Warranty

New parts purchased are warranted to be free from defects for a period of 1 year. Parts warranty is repair or replace only. Parts warranty is limited to the repair or replacement of the defective part only. No labor allowed for parts warranty. The defective part will be repaired or replaced. Freight and labor are not covered under the parts warranty. FOR A DEFECTIVE PART, CONTACT THE WARRANTY SERVICE CENTER (800-531-9656 or 972-352-6304).

Certificate of Limited Warranty Rotary Screw Compressors

All component parts on this compressor, installed by the manufacturer, are warranted to be free of defects in workmanship and material for a period of one year. Transportation charges are the responsibility of the purchaser. This warranty extends to the original purchaser of the compressor only. The purchaser must use Synthetic Rotary Screw Oil, Part Number RS8000, in the compressor for the duration of the compressor warranty. There are NO express warranties other than those contained in this limited warranty statement. Covered in the one year period of warranty are defective parts and labor. Part defects are limited to original part only. The compressor warranty is void in the cases of abuse, lack of proper service, incorrect application, incorrect installation and neglect. Industrial Electric stationary compressors may be repaired on site as long as the compressor is not located further than 50 miles from the service center. The purchaser is responsible for any additional travel expense beyond 50 miles from the service center. Gas/Diesel Engine Driven compressors must be repaired at the closest service center to the compressor. The purchaser is responsible for any travel expense if they do not wish to bring the compressor to the service center. ALL "SPECIALTY COMPRESSOR" WARRANTY SERVICE MUST BE PERFORMED AT THE CLOSEST SERVICE CENTER TO THE COMPRESSOR. A "SPECIALTY COMPRESSOR" is any compressor packaged with options other than those that apply to the standard model in the catalog. The AIREND is covered by a 2 year warranty to be free from defects from manufacturing. This does not cover abuse, neglect, improper service, misapplication, or improper installation. An oil sample must be submitted with any AIREND warranty claim for verification. An "AIREND" is the rotors and bearings of the compressor. Warranty labor for the first year is only covered for work performed Monday-Friday 8am-5pm excluding all major US holidays. BEFORE WARRANTY SERVICE IS PERFORMED, PLEASE CONTACT MANUFACTURER TECH SUPPORT FOR FASTEST SOLUTION AND AUTHORIZATION (800-531-9656 or 972-352-6304). Warranty repairs must be authorized by the manufacturer prior to work being performed. Unauthorized work may void the package warranty. The warranty claim form MUST be submitted for any potential warranty claim to be reviewed. A copy of the original invoice must be sent in with the warranty claim form.

The limited warranty is not active until the installation sheet, included with the compressor manual, is properly filled out and returned. Failure to return the installation sheet will prevent the warranty from being active.

THIS POLICY IS LIMITED TO THE ITEMS ON THE INVOICE, WHICH IS ATTACHED WITH THIS DOCUMENT.

THIS INSTALLATION SHEET MUST BE FILLED OUT AND RETURNED FOR WARRANTY TO BEGIN

Gas/Diesel Engine Rotary Screw Compressor Installation Sheet

Compressor & Installer

Compressor Model # _____ Compressor Serial # _____

Installation Company: _____ Installation Technician: _____

Technician Signature: _____ Date: _____

Drive Engine & Installation Status

Drive Engine: Gasoline Diesel Natural Gas Battery Powered

Location of Install: Truck Body (Open) Van Trailer Box Truck Other: _____

Unit Installed in Weather-Proof Enclosure: Yes No

Auxiliary Fuel Tank Needed: Yes No

Auxiliary Fuel Pump Needed: Yes No

Wiring Extension Added: Yes No

Wiring Extension Technician: _____

Unit Cooling Fan: Pulls Air Through Cooler Pushes Air Through Cooler

Remote Air/Oil Cooler Installed: Yes No *If Yes, Distance From Compressor Package: _____ft*

Performance

Max Operating Pressure: _____ PSI

Tank Drain Functional: Yes No

Checked All Air Fittings for Leaks: Yes No

Checked Unit for Oil Leaks: Yes No

Checked Belt Tension After Start-Up: Yes No

Vibration Pads Properly Installed: Yes No

Tank Fill Time: 0-125 PSI: _____ *Write N/A if pressure not applicable to unit*

0-150 PSI: _____ *Write N/A if pressure not applicable to unit*

0-175 PSI: _____ *Write N/A if pressure not applicable to unit*

Compressor Temperature Gauge Readings: Before Start-Up: _____ After Start-Up: _____

All Install Steps Completed: Yes No *If No, Explain: _____*

Send a copy of this completed installation sheet to manufacturer to begin warranty.

Include the following:

- 1 image of the control panel wired up
- 1 image of the full install
- 1 image from each end of the compressor

Sales@industrialgold.com

Fax 972-352-6304

Or mail to

Industrial Gold

600 S. 2nd Ave Mansfield, TX, 76063



Industrial Gold

600 S 2nd Ave
Mansfield, TX, 76063

1-800-531-9656

Fax 972-352-6364

Quality Air Compressor at a Great Price.