

RS3.5 Rotary Screw Airend

Owner's
Manual

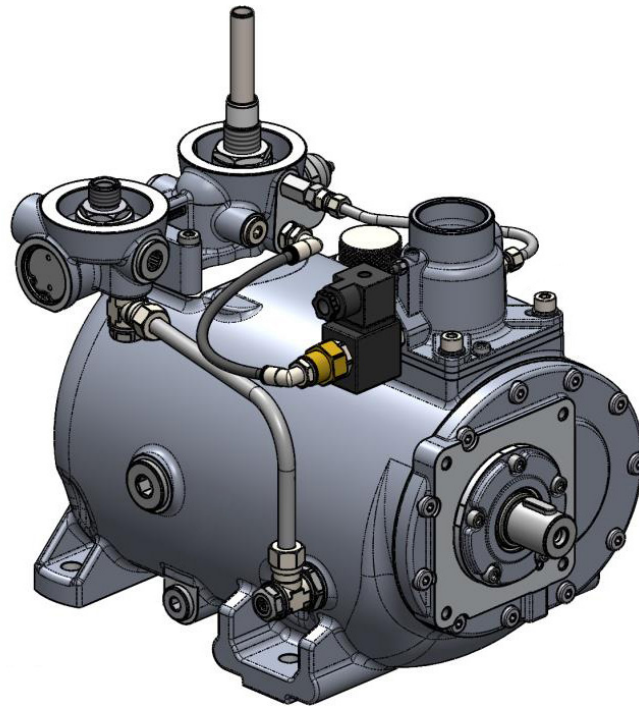

Introduction: Congratulations on the purchase of your new air compressor. The air compressor is precision built from the finest materials using the finest state of the art design, and high tech engineering available today. Quality, performance and trouble free operation will assure you a dependable supply of air power on demand.

Check www.industrialgold.com for most up to date manual, compressor service, and technical information.

CAUTION: Read this manual carefully before operating or servicing this air compressor, to familiarize yourself with the proper safety, operation, and standard operating procedures of this unit. **FAILURE TO COMPLY WITH INSTRUCTIONS IN THIS MANUAL COULD RESULT IN THE VOIDING OF YOUR WARRANTY, AND PERSONAL INJURY, AND/OR PROPERTY DAMAGE. THE MANUFACTURER OF THIS AIR COMPRESSOR WILL NOT BE LIABLE FOR ANY DAMAGE BECAUSE OF FAILURE TO FOLLOW THE INSTRUCTIONS IN THIS MANUAL.** By following the instructions and recommendations in this manual you will ensure a longer and safer service life of your air compressor.

NOTICE: All air compressors must be installed by a qualified and trained technician. If you need a qualified technician, call 800-531-9656 or 972-352-6304. Improper installation may result in damage to the compressor, personal injury, and will void the warranty of the compressor package.

If you have questions or need clarification about this manual or your compressor call 800-531-9656

Do not operate compressor outdoors in wet weather

Industrial Gold

Quality Air Compressors at a Great Price.

industrialgold.com ■ 1-800-531-9656 ■ Fax 972-352-6364

© Industrial Gold 04-2026



Scan to visit our website



Contents

Warnings and Precautions	2
Engineering Data.....	3
Unpacking.....	5
Installation	6
First Start	9
Calibrating Minimum Pressure Valve	10
Security In Handling, Installation, Usage And Servicing.....	11
Maintenance and Parts Kits	12
Troubleshooting	15
Warranty	17

Industrial Gold is not liable for damages to people and/or objects caused by a misuse of the RS3.5, noncompliance or partial compliance with safety standards mentioned in this document, changes (even small ones), tampering, and use of non-original spare parts.

WARNINGS AND PRECAUTIONS

1. Before starting any operations, read this document carefully. The disregard of the information herein contained can damage and injure people and property.
2. Use cylinder thread connections, unless otherwise indicated. If you do not, malfunctioning of the product can be caused.
3. Installation and maintenance must be carried out only by qualified staff. Always comply with current safety and accident prevention regulation.
4. Use suitable protective clothes during installation and maintenance (for example: overalls, gloves, protective glasses, earplugs and caps, etc.).
5. All installation and maintenance operations must be carried out both when the machine is switched-off (environment pressure) and when the electrical circuit is off.
6. Transmission parts like couplings and pulleys must be safe. Check air/oil pipe seals. Do not touch the mobile elements of the product when the machine is on.
7. Equipment and/or other systems used for motion, installation and maintenance will have to be adequately gauged in terms of weight and geometry. Protruding parts must be sheltered when the machine is on.
8. The manufacturer is not liable for damages to people and/or objects that may be caused by product misuse, non-compliance or partial compliance with safety standards mentioned in this document, changes even small ones, as well as tampering and use of non-original spare parts.



The installation, wiring, and all electrical controls must be in accordance with ANSI C1 National Electric Code, ANSE C2 National Electric Safety Code, state and local codes. All electrical work should be performed by a qualified electrician. Failure to abide by the national, state and local codes may result in physical and/or property damage.

WARNING: Always wear proper protective eye ware, hearing protection and safety clothing when working around the compressor package. No loose or baggy clothing should be worn around compressor package at any time.

NOTICE: Industrial Gold compressors can operate at pressures from 0-250 PSI depending on the compressor package design and build specifications. Always verify that the system the compressor is installed into can handle the maximum operational pressure of the compressor. NEVER install a compressor in a system that can not handle the compressors maximum operating pressure.

Engineering Data

Type of machine	Oil-injected rotary screw compressor	
Drive	Direct or belt	
Rotor outside dimension:	73.4 mm	2.9 in
Rotor dimension: L/D	1.65	
Air capacity (ISO 1217 annex B 2009)	0.65 - 2.1 m ³ /min	22.9 - 74 CFM
Oil capacity	4.5 Liters	4.75 Quarts
Max working pressure	13 bar(g)	188.6 PSIG
Min working pressure	5 bar(g)	72.5 PSIG
Oil injected quantity	20 - 28 l/min	5.3 - 7.39 GPM
Max input power	15 kW	20 HP
Max main rotor speed	7500 RPM	
Min main rotor speed	2850 RPM	
Max outlet air/oil temperature	105°C	221°F
Environment max temperature	45°C	113°F
Environment min temperature *	0°C	32°F
Thermostatic temperature	55 – 71 – 83°C	131 – 159.8 – 181.4°F
Oil nipple size	G3/4" – 3/4"-16UNF – 1"-12UNF	
Separator nipple	M22x115mm – M24x195mm	
Operating pressure	8bar – 10bar – 13bar	
Materials	Air-end body: cast iron; Valve body: aluminum; Internal parts: anodized aluminum, steel, brass, PTFE, Viton.	
Weight	24.5 Kg	54 lbs

Power Curves

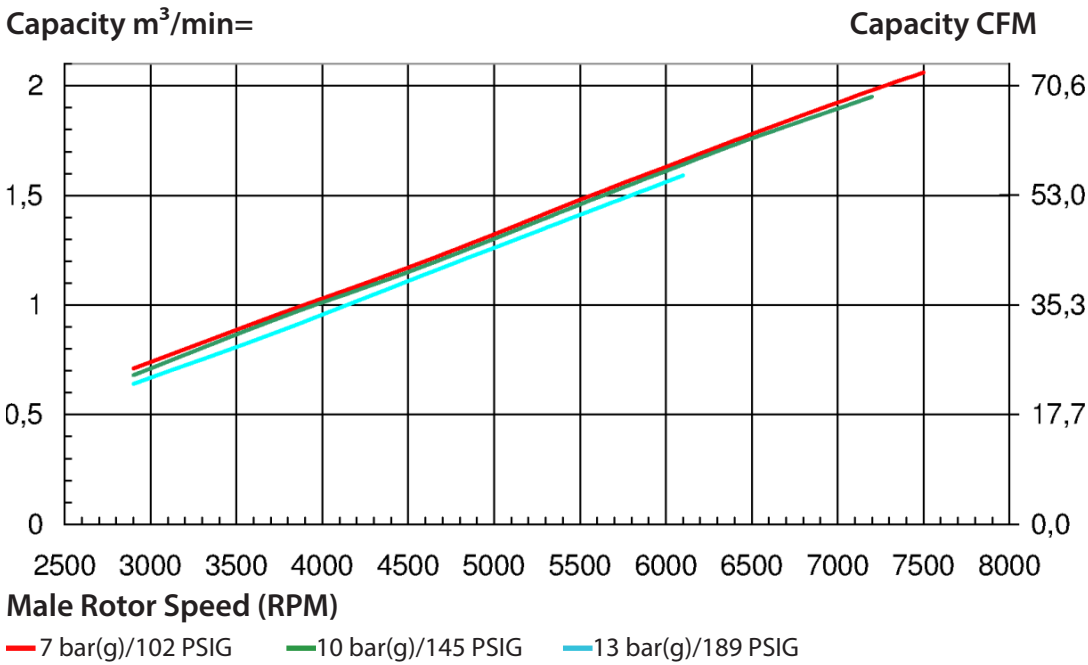
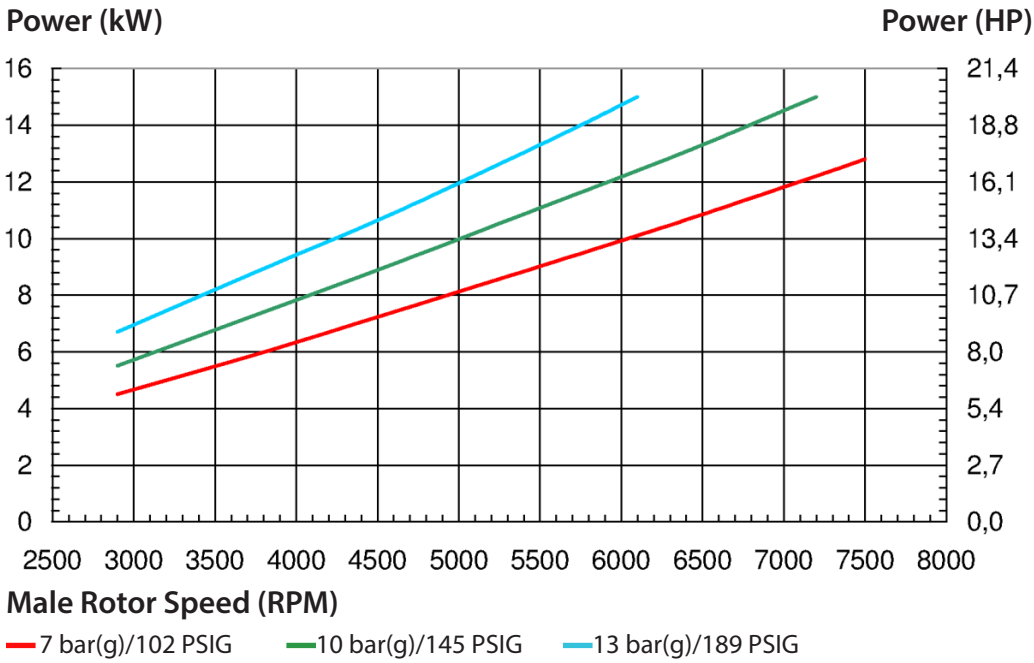

SUCTION PRESSURE: 1 BAR(A)/14.5 PSIA
 SUCTION TEMPERATURE: 20°C/68°F
 RELATIVE HUMIDITY: 60%
 AIR FLOW RATE RELATED TO SUCTION CONDITION ACCORDING TO: ISO 1217 ANNEX B 2009

Unpacking

Carefully unpack your RS3.5 and check the integrity of its elements, such as the support feet, the airend shaft, the safety valve, the intake valve, the oil drain plug, the oil recovery viewer and the separator tank. Check that the packaging contents correspond to the list of components indicated in figure 1.

WARNING! The tank contains oil! Figure 2 shows the correct position for the oil separator unit to avoid oil leaks.

FIGURE 1

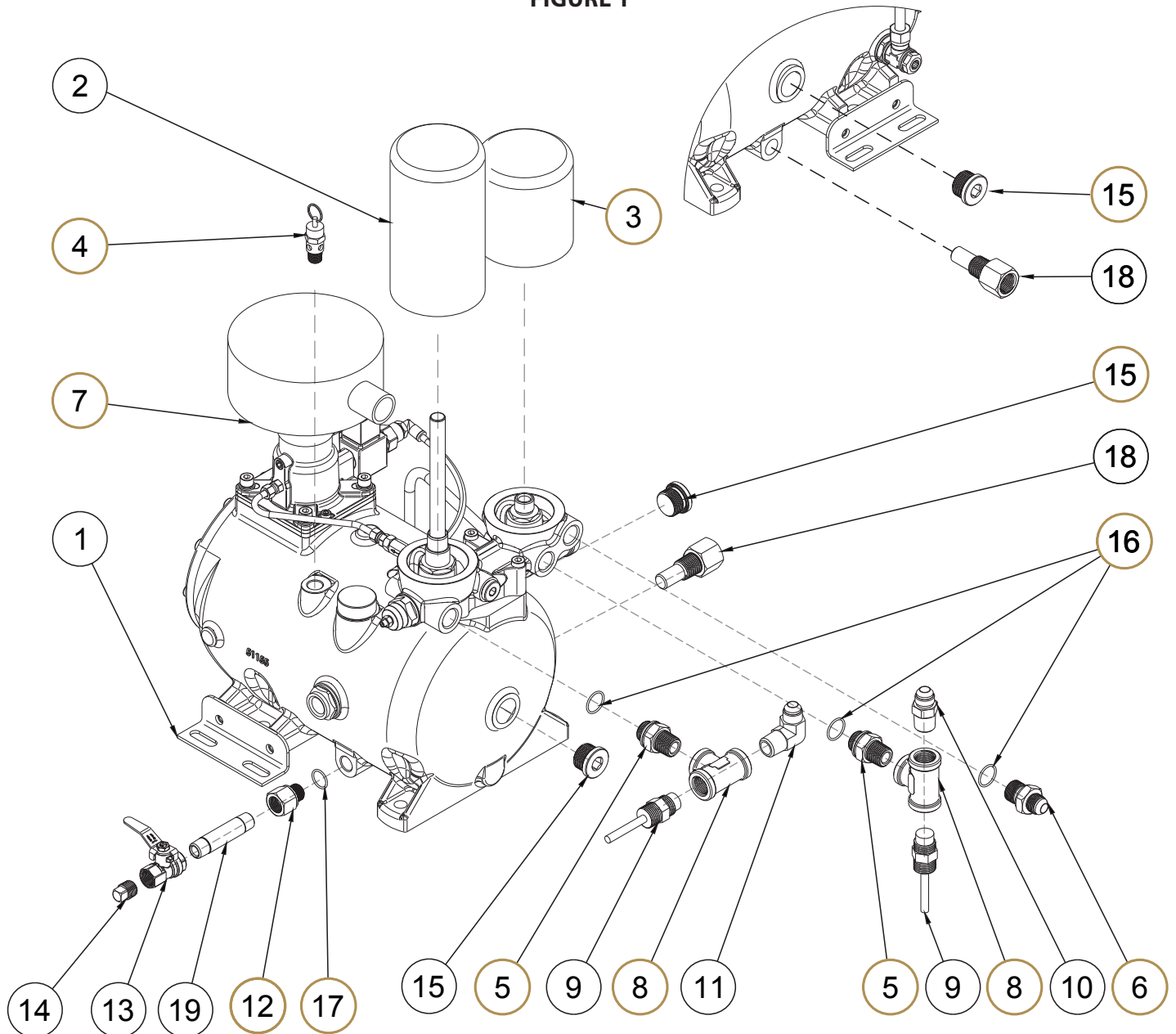

Item	QTY	Part Number	Item	QTY	Part Number	Item	QTY	Part Number
1	2	IAT-RS3-BRKT V10	8	2	IAT-1/2TEE BKPIPE	15	1	IAT-BPP-6408-HHP12EO
2	1	IAT-SE-1	9	2	IAT-RTD-SS-1/2-10	16	3	IAT-BPP-6001-08
3	1	IAT-OF1	10	1	IAT-2404-08-08	17	1	IAT-BPP-6001-006
4	1	IAT-SRV250-3/8BPP200	11	1	IAT-2501-08-08	18	1	IAT-R-4565
5	2	IAT-BPP-MP-5404-08-8	12	1	IAT-BPP-FP-5405-0606	19	1	IAT-PF3/8X3NIPPLE
6	1	IAT-BPPMJ64000808-WO	13	1	IAT-716113 V4	Items in gold are included in RS3.5 Kit		
7	1	IAT-RS3.5	14	1	IAT-PF3/8"BLK PLUG			

Installation

When installing the RS3.5, check that the intake regulator is not blocked by foreign bodies. Make sure all connections to the cooler are connected correctly as shown in figure 2, to prevent air and oil from leaking into the environment.

WARNING! The cooler must be sized to ensure proper oil flow and temperature regulation. It is recommended to minimize the cooler's internal volume to avoid harmful fluctuations in the oil level in the tank.

FIGURE 2

A = Air inlet to the cooler

B = Oil inlet to the cooler (hot oil)

C = Oil return from cooler (cold oil)

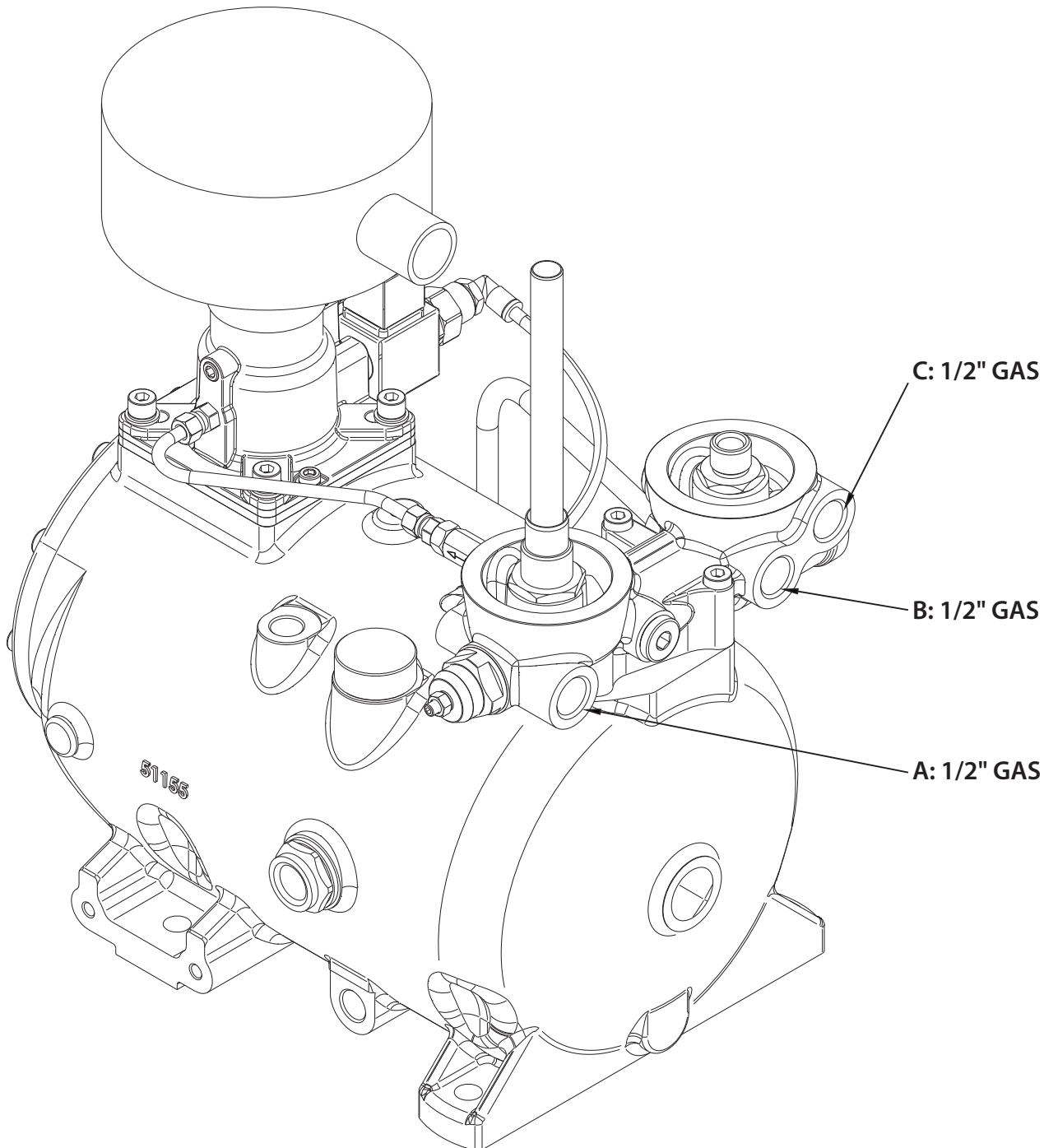

Installation

If it is necessary to clean and lubricate the end of the screw shaft, avoid touching the oil seal to avoid damaging it. Make sure the compressor is securely attached to the machine base using the appropriate mounting holes shown in figure 3. If the integrated system needs to be painted, avoid contact with solvents or paints by protecting the identification plate, seals, intake port, external threads, and all sealing surfaces beforehand.

WARNING: Only use fittings with cylindrical GAS threads. Using fittings with tapered GAS threads may damage the airend.

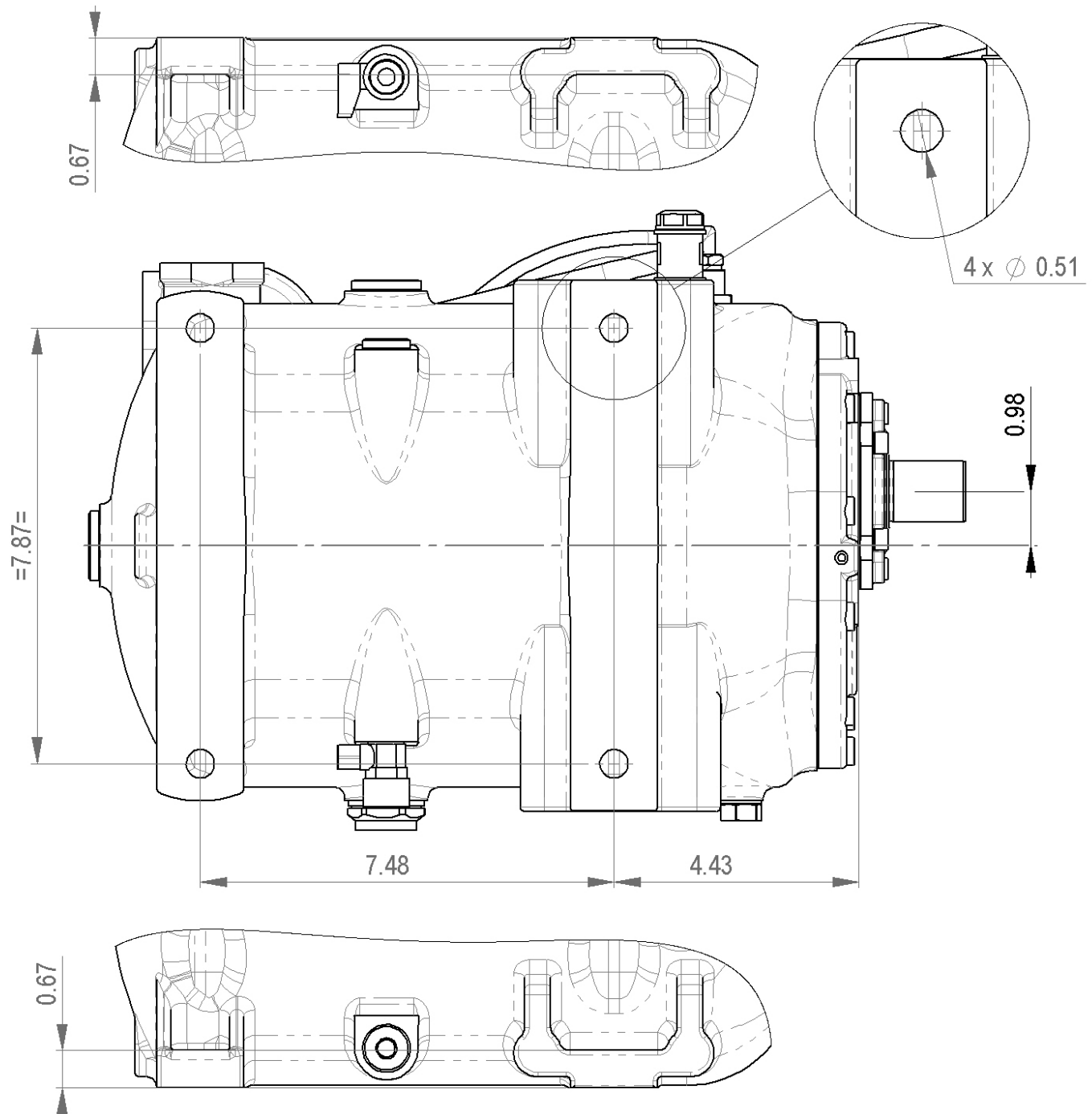

FIGURE 3

MOTOR CONNECTION

After connecting the electrical motor to the airend, check that the direction of its rotation corresponds to the one indicated by the arrow on the body of the airend (see the figure 4).

WARNING! ROTATING THE SHAFT IN THE WRONG DIRECTION CAN DAMAGE THE AIREND.

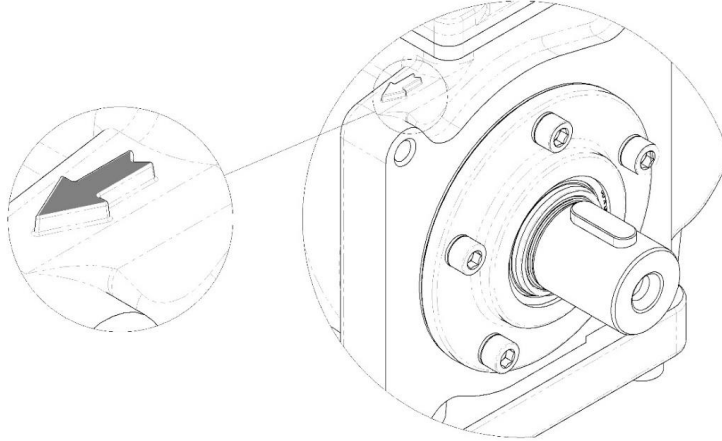

FIGURE 4

DIRECT DRIVE WITH COUPLING

If the transmission between airend and motor shaft is direct driven, the two shafts must be connected together using a flexible coupling (figure 5).

WARNING! Do not lubricate the flexible coupling. Correctly lineup the motor shaft with the airend shaft. The flexible coupling must be protected to avoid accidents.

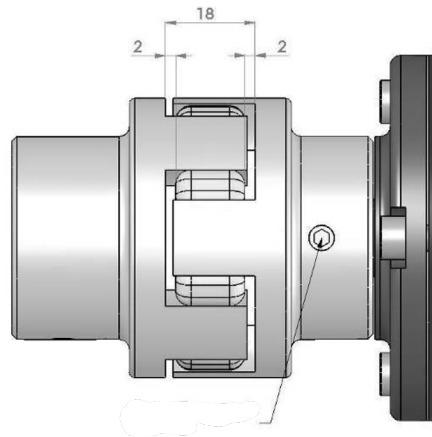

FIGURE 5

BELT DRIVE

If the transmission between the airend shaft and the engine is belt driven, make sure that the pulleys on the shafts are correctly lined-up, and the belts properly tightened. For a belt transmission, we recommend the use of Poly V style belts. Belt tension must not exceed 1500N. For the pulley mounted on the airend shaft, we advise against a diameter smaller than 2.75 inches.

Note: Max allowable load at the shaft's end is 1500N (=750N for each side of the belt).

WARNING! An excessive belt tension shortens the airend bearings life. Guards must be fastened in place before starting the compressor and never removed before cutting off and locking out the main power supply.

First Start

The RS3.5 could contain some residual mineral oil inside its circuit due to carried out tests. We recommend that you complete a “washing cycle” to avoid any problems with lubricant mix incompatibility.

1. Before starting the compressor, inject about 12 ounces (0.4L) of RS8000 synthetic lubricating into the intake valve air inlet, keeping the valve pressed down, and at the same time, manually rotating the rotors in the right direction (figure 6). While pressing down the throttle, be careful to avoid damages to the throttle O-ring seal (figure 7).
2. Drain all the oil contained in the system.
3. Fill the tank with RS8000 synthetic lubricating oil, up to the level indicated by the viewer (figure 8).
4. Start the compressor and let it run for about 5 minutes.
5. Switch off the compressor. Discharge the pressure. Drain all the synthetic oil contained in the RS3.5 through the oil drain valve.
6. Again, fill the tank with unused RS8000 synthetic lubricating oil, up to the level indicated by the viewer (figure 8).
7. Again, start the compressor and let it run for about 5 minutes.
8. Switch off the compressor. Discharge the pressure. Top up the lubricant up to the level shown by the viewer, through the oil-filling hole (figure 8).

WARNING! Before any oil extraction or oil fill-up operation, switch off the machine and wait until the system pressure reaches the environment pressure. Handle the lubricant with proper protection.

WARNING! If you do not carry out the “washing cycle” as described above, lubricating problems may arise due the lubricant mix incompatibility. Dispose of the mineral oil complying with current waste disposal regulations.

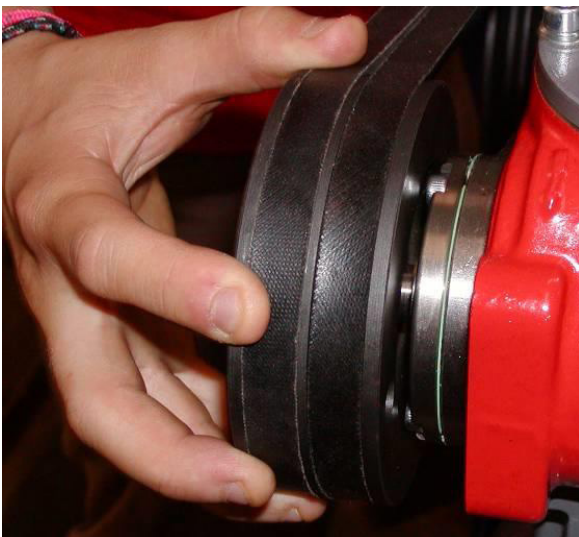

FIGURE 6

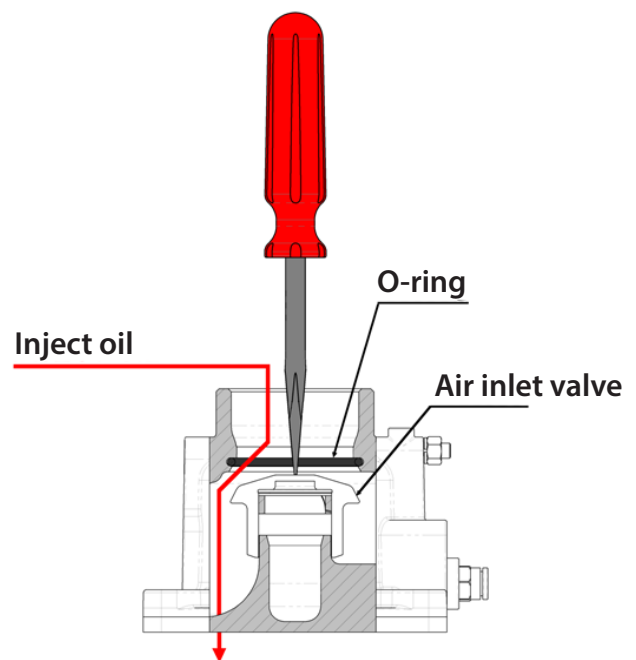

FIGURE 7

NOTE:

When the unit is running, the oil level should be towards the bottom of the sightglass.

When the unit is not running, the oil level should be halfway up the sightglass.

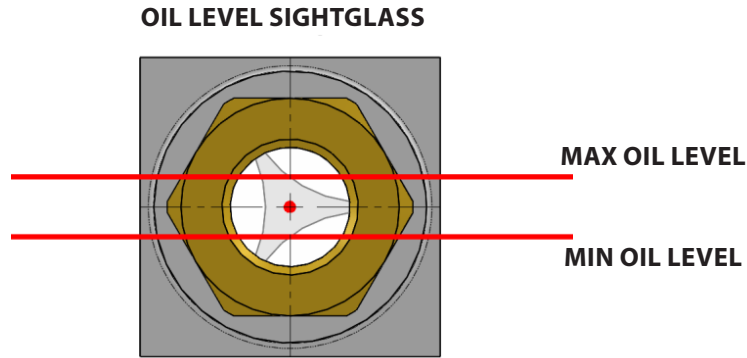

FIGURE 8

Tips For The First Start-Up

Following the oil topping-up operation for the airend, start the machine and switch it off after a couple of seconds to loading a small quantity of air.

If the airend shaft doesn't turn in the right direction the machine will not load air. Check the arrow on the airend body for the correct indication (see figure 4). If the shaft rotation is not correct, adjust the motor electrical connections. Double-check the correct direction rotation, start the machine again.

The shaft rotation direction can be checked as follows:

1. For the belt drive, check the pulley rotation direction. It must be the same as the direction shown on the arrow embossed on the airend body.
2. For the direct-coupled drive, check the rotation direction of the coupling, through the slits of the bell housing: it must be the same as direction shown on the arrow embossed on the airend body.

Instructions For Calibrating The Minimum Pressure Valve

TO INCREASE THE MINIMUM PRESSURE:

Unscrew the locking nut (b2) and slowly tighten the pressure control screw (b). When you reach the desired pressure, retighten the locking nut (b2), finalizing the new setting (picture 9).

TO DECREASE THE MINIMUM PRESSURE

Unscrew the locking nut (b2) and slowly loosen the pressure control screw (b). When you reach the desired pressure, retighten the locking nut (b2), finalizing the new setting (picture 9).

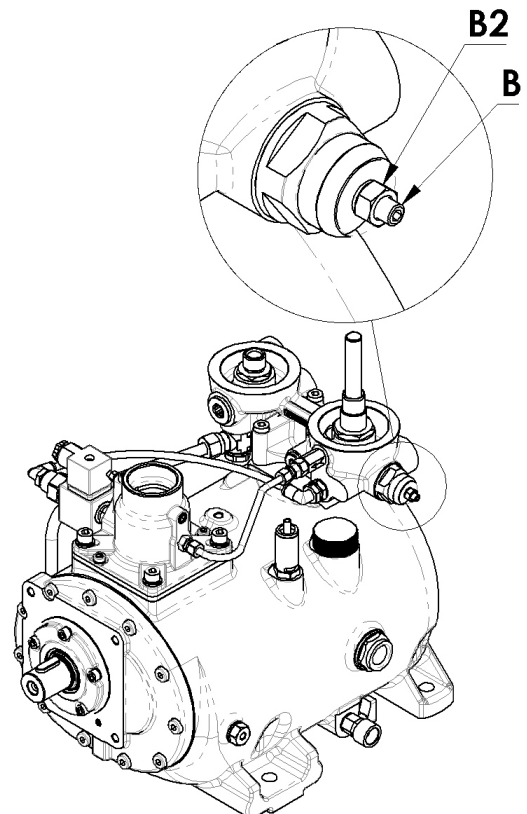

FIGURE 9

Safety In Handling, Installation, Usage And Servicing

HANDLING

Equipment and/or other systems used to move the machine and/or its components must be correctly sized in terms of weight and geometry. The protruding components have to be properly protected whenever the machine is moved or shifted (we recommended to protect all the components shown in picture 1). The airend must be handled by specialized staff only.

INSTALLATION

Secure the transmission parts, like couplings and pulleys. Check the sealing of air/oil pipes. During the installation, cut off the power supply, then secure the solenoid valve (if provided) electrical cable connections. The airend must be installed by specialized staff only.

USAGE

Check the recommended temperature sensor and safety valve positions in figure 1. The temperature sensor seat is designed for a sensor with dimensions shown in figure 10.

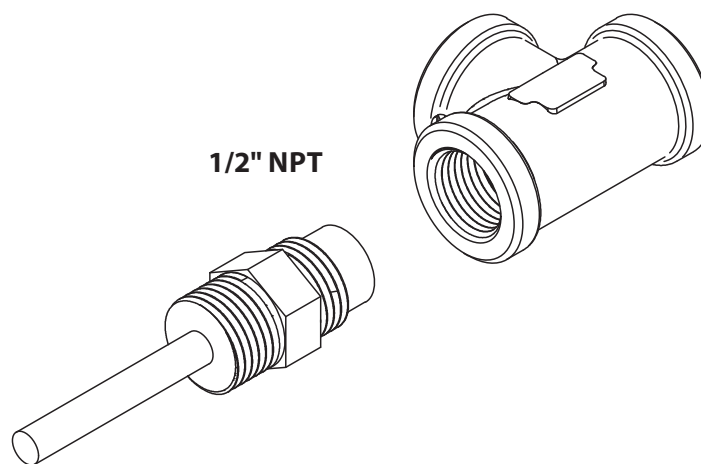

FIGURE 10

WARNING: If the machine is inactive for extended periods (more than 60 days), repeat the airend lubrication procedure, by injecting 12 ounces of lubricant through the regulator intake port, (see First Start section)



CAUTION

The installation, wiring, and all electrical controls must be in accordance with ANSI C1 National Electric Code, ANSE C2 National Electric Safety Code, state and local codes. All electrical work should be performed by a qualified electrician. Failure to abide by the national, state and local codes may result in physical and/or property damage.

ELECTRICAL

Always disconnect power at the source before installing or servicing the unit. Working on a live electrical system can cause serious injury or equipment damage.

NOTICE: Air compressors must be installed by trained installation personnel. Installation sheets must be sent back in for warranty activation. If you need help finding a qualified technician to properly perform installation, call 800-531-9656 or 972-352-6304.

Maintenance Kits

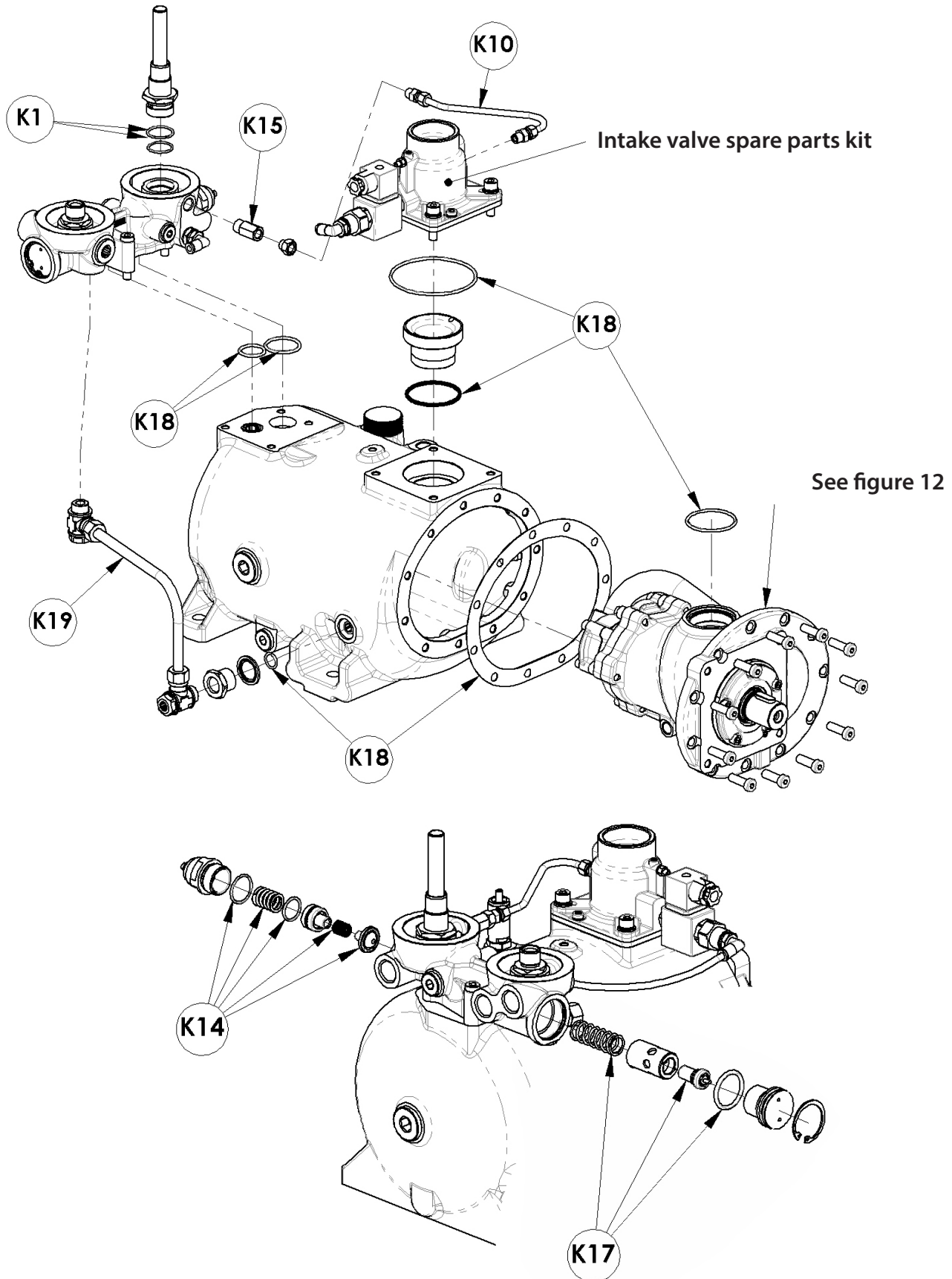

FIGURE 11

Maintenance Kits

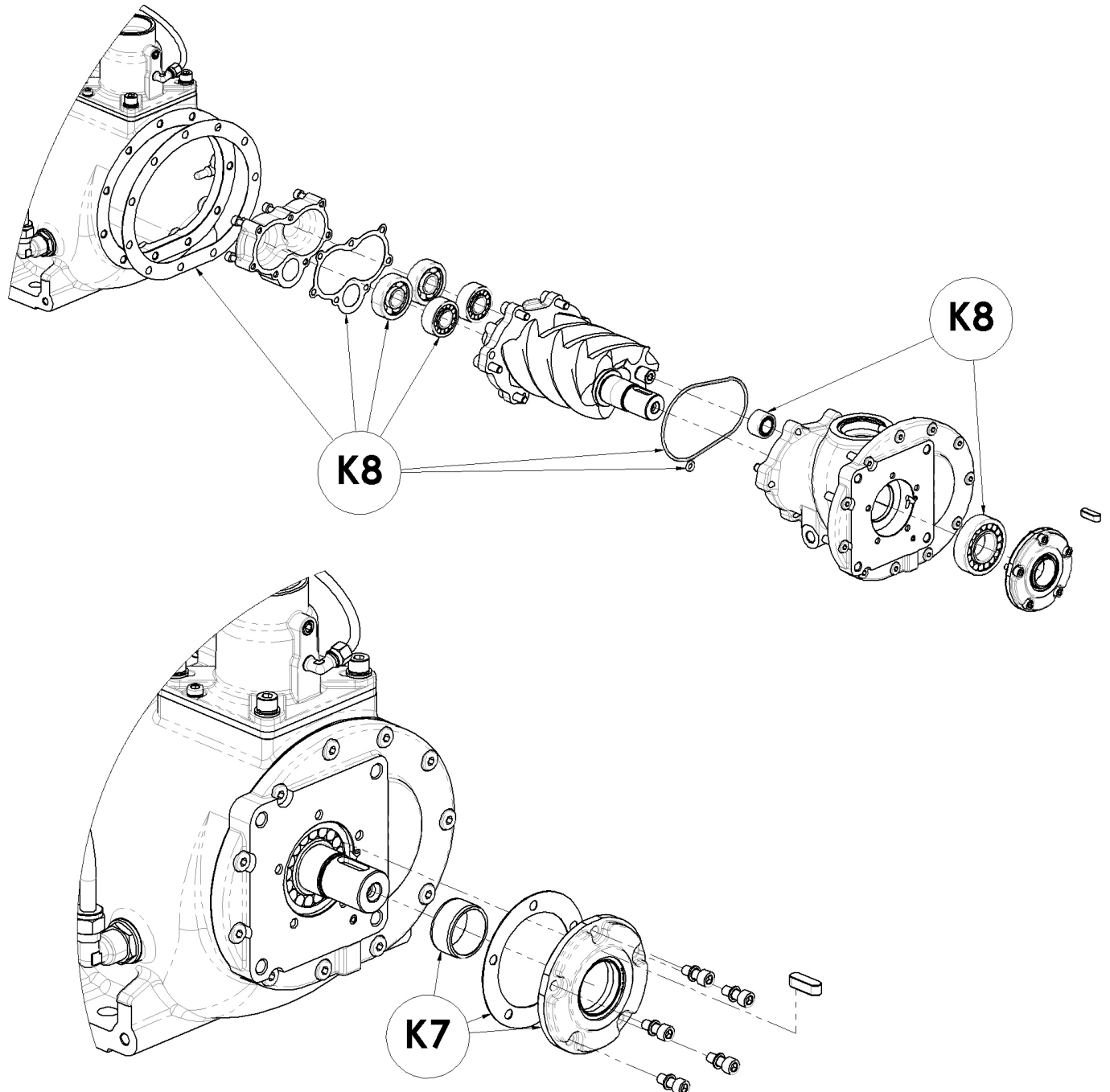

FIGURE 12

Maintenance Kits

The following table shows a schedule for the maintenance of a ADAM. The table indicates working hours for a standard machine. These working hours can be modified depending on work environment and cycle numbers.

KIT	PART NUMBER	DESCRIPTION	VARIANT			MAINTENANCE TIME
			55°	71°	83°	
K1	270.0590	Separator nipple m22-24 spare parts kit	•	•	•	8000 hours
K7	940.0649	Shaft-seal spare parts kit	•	•	•	10000 hours
K8	728.0022	Bearings spare parts kit	•	•	•	20000 hours
K10	728.0091	Oil recovery spare parts kit	•	•	•	Corrective maintenance
K14	220.0010	G10 M.P.V. Spare parts kit	•	•	•	8000 hours
K15	220.1802	VRO19 oil recovery viewer	•	•	•	Corrective maintenance
K17	270.1390	VT-VT-VTFT 25/27 55° spare parts kit	•			8000 hours
	270.1380	VT-VT-VTFT 25/27 71° spare parts kit		•		
	270.1385	VT-VT-VTFT 25/27 83° spare parts kit			•	
K18	728.0071	Tank sealings adamv75x spare parts kit	•	•	•	Corrective maintenance
K19	728.0071	Oil injection fittings adamv75x spare parts kit	•	•	•	Corrective maintenance

Troubleshooting

You should always contact an authorized service center before attempting to fix or repair your air compressor.

Always make sure electrical power is off before removing any inspection covers or plates or before servicing compressor.

Problem	Possible causes	Solutions
The compressor does not load.	<ul style="list-style-type: none"> A. The intake valve remains closed. B. The solenoid valve does not work properly. C. Leaks in the pressure line. D. The GHS100 valve does not work properly (if present). 	<ul style="list-style-type: none"> A. Check the valve. If necessary, replace the damaged parts with the specific spare parts kit. B. Check the solenoid valve. If necessary, replace it. C. Check pipes and cables. If necessary, fix or replace them. D. Check the valve. If necessary, replace the damaged parts with the specific spare parts kit.

Troubleshooting

Problem	Possible causes	Solutions
During unloading phase, the compressor does not discharge pressure from separator tank.	<ul style="list-style-type: none"> A. The solenoid valve does not work properly. B. The calibrated nozzle is clogged. Low voltage. C. The GHS100 valve does not work properly (if present). 	<ul style="list-style-type: none"> A. Check the solenoid valve. If necessary, replace it. B. Remove the calibrated nozzle. Clean or replace it. C. Check the valve. If necessary, replace the damaged parts with the specific spare parts kit.
Compressor capacity or pressure lower than usual standard.	<ul style="list-style-type: none"> A. The air filter is clogged. B. The intake valve does not open. C. Air loss from safety valve. 	<ul style="list-style-type: none"> A. Remove the air filter. Clean or replace it. B. Check the valve. If necessary, replace the damaged parts with the specific spare parts kit. C. Replace the valve.
Compressor keeps loading over working pressure. Safety valve opens.	<ul style="list-style-type: none"> A. The solenoid valve does not work properly. B. Clogged separator filter. 	<ul style="list-style-type: none"> A. Check the solenoid valve. If necessary, replace it. B. Replace the separator filter.
Compressor overheating.	<ul style="list-style-type: none"> A. Insufficient cooling. B. Dirty oil. C. Oil level is too low. D. Clogged-up cooler or pipe connection. E. The thermostatic valve does not work properly. F. Clogged oil filter. 	<ul style="list-style-type: none"> A. Check the cooling system. B. Replace it with new oil. C. Check oil level and if necessary, add oil. D. Clean cooler and pipes. E. Check the thermostatic valve. If necessary, replace the damaged parts with K17 spare parts kit. F. Replace the oil filter.
During unloading phase, pressure increases up to safety valve opening.	<ul style="list-style-type: none"> A. The intake valve remains open. B. The calibrated nozzle is clogged. 	<ul style="list-style-type: none"> A. Check the valve. If necessary, replace the damaged parts with the specific spare parts kit. B. Remove the calibrated nozzle. Clean or replace it.
Oil leakage from intake valve only when the machine is switched off.	<ul style="list-style-type: none"> A. The intake valve does not work properly (does not close). B. The non-return valve of intake valve does not work properly. C. The GHS100 valve does not work properly (if present). 	<ul style="list-style-type: none"> A. Check the valve. If necessary, replace the damaged parts with the specific spare parts kit. B. Check the valve and clean it if necessary. C. Check the valve. If necessary, replace the damaged parts with the specific spare parts kit.

Troubleshooting

You should always contact an authorized service center before attempting to fix or repair your air compressor.

Always make sure electrical power is off before removing any inspection covers or plates or before servicing compressor.

Problem	Possible causes	Solutions
Air filter soaks up oil during unloading phase.	<ul style="list-style-type: none"> A. Too high level of oil in the tank. B. Clogged separator filter. C. The oil recovery viewer is dirty or does not work properly. 	<ul style="list-style-type: none"> A. Check oil level on separator tank (see the chapter 6). B. Replace the separator filter. C. Clean it. If necessary, replace the damaged parts with the K11 spare parts kit. If separator filter is clogged up, replace it.
The compressor remains in loading phase.	<ul style="list-style-type: none"> A. The intake valve does not work properly (does not close). 	<ul style="list-style-type: none"> A. Check the valve. If necessary, replace it (K15).
In stop phase, without using the air, the pressure in the air tank drops.	<ul style="list-style-type: none"> A. Losses in the air circuit. B. The minimum pressure valve does not work properly. 	<ul style="list-style-type: none"> A. Check the air circuit. B. Check the valve. If necessary, replace the damaged parts with K14 spare parts kit.
Rotor seizure.	<ul style="list-style-type: none"> A. Unknown particles inside. B. Insufficient lubrication. 	<ul style="list-style-type: none"> Call IG technical support.
Oil leaks in the outlet of minimum pressure valve.	<ul style="list-style-type: none"> A. Separator filter damaged. B. Clogged oil recovery viewer. C. Damaged O-ring of the separator nipple. 	<ul style="list-style-type: none"> A. Replace the separator filter. B. Clean the oil recovery viewer. C. Replace K1 spare parts kit.

Certificate of Limited Warranty Reciprocating Compressors and Parts

All component parts on this compressor, installed by the manufacturer, are warranted to be free of defects in workmanship and material for a period of one year. Transportation charges are the responsibility of the purchaser. This warranty extends to the original purchaser of the compressor only. The purchaser must use Synthetic Reciprocating Compressor Oil, Part Number 30100, in the compressor for the duration of the compressor warranty. There are NO express warranties other than those contained in this limited warranty statement. Covered in the one year period of the warranty are defective parts and labor only. Part defects are limited to original parts only. The compressor warranty is void in the case of abuse, lack of proper service, incorrect application, incorrect installation, and neglect. Industrial Electric stationary compressors may be repaired on site as long as the compressor is not located further than 50 miles from the service center. The purchaser is responsible for any additional travel expense beyond 50 miles from the service center. Gas/Diesel Engine Driven, Single Stage Stationary, and Contractor Series compressors must be repaired at the closest service center to the compressor. The purchaser is responsible for any travel expense if they do not wish to bring the compressor to the service center. ALL "SPECIALTY COMPRESSOR" WARRANTY SERVICE MUST BE PERFORMED AT THE CLOSEST SERVICE CENTER TO THE COMPRESSOR. A "SPECIALTY COMPRESSOR" is any compressor packaged with options other than those that apply to the standard models in the catalog. Warranty labor for the first year is only covered for work performed Monday-Friday 8am-5pm excluding all major US holidays. BEFORE WARRANTY SERVICE IS PERFORMED, CONTACT THE MANUFACTURER TECH SUPPORT FOR FASTEST SOLUTION AND APPROVAL (800-531-9656 or 972-352-6304). Warranty repairs must be authorized by the manufacturer prior to work being performed. Unauthorized work may void the package warranty. The warranty claim form MUST be submitted for any potential warranty claim to be reviewed. A copy of the original invoice must be sent in with the warranty claim form.

The limited warranty is not active until the installation sheet, included with the compressor manual, is properly filled out and returned. Failure to return the installation sheet will prevent the warranty from being active.

Certificate of Limited Warranty Parts Warranty

New parts purchased are warranted to be free from defects for a period of 1 year. Parts warranty is repair or replace only. Parts warranty is limited to the repair or replacement of the defective part only. No labor allowed for parts warranty. The defective part will be repaired or replaced. Freight and labor are not covered under the parts warranty. FOR A DEFECTIVE PART, CONTACT THE WARRANTY SERVICE CENTER (800-531-9656 or 972-352-6304).

Certificate of Limited Warranty Rotary Screw Compressors

All component parts on this compressor, installed by the manufacturer, are warranted to be free of defects in workmanship and material for a period of one year. Transportation charges are the responsibility of the purchaser. This warranty extends to the original purchaser of the compressor only. The purchaser must use Synthetic Rotary Screw Oil, Part Number RS8000, in the compressor for the duration of the compressor warranty. There are NO express warranties other than those contained in this limited warranty statement. Covered in the one year period of warranty are defective parts and labor. Part defects are limited to original part only. The compressor warranty is void in the cases of abuse, lack of proper service, incorrect application, incorrect installation and neglect. Industrial Electric stationary compressors may be repaired on site as long as the compressor is not located further than 50 miles from the service center. The purchaser is responsible for any additional travel expense beyond 50 miles from the service center. Gas/Diesel Engine Driven compressors must be repaired at the closest service center to the compressor. The purchaser is responsible for any travel expense if they do not wish to bring the compressor to the service center. ALL "SPECIALTY COMPRESSOR" WARRANTY SERVICE MUST BE PERFORMED AT THE CLOSEST SERVICE CENTER TO THE COMPRESSOR. A "SPECIALTY COMPRESSOR" is any compressor packaged with options other than those that apply to the standard model in the catalog. The AIREND is covered by a 2 year warranty to be free from defects from manufacturing. This does not cover abuse, neglect, improper service, misapplication, or improper installation. An oil sample must be submitted with any AIREND warranty claim for verification. An "AIREND" is the rotors and bearings of the compressor. Warranty labor for the first year is only covered for work performed Monday-Friday 8am-5pm excluding all major US holidays. BEFORE WARRANTY SERVICE IS PERFORMED, PLEASE CONTACT MANUFACTURER TECH SUPPORT FOR FASTEST SOLUTION AND AUTHORIZATION (800-531-9656 or 972-352-6304). Warranty repairs must be authorized by the manufacturer prior to work being performed. Unauthorized work may void the package warranty. The warranty claim form MUST be submitted for any potential warranty claim to be reviewed. A copy of the original invoice must be sent in with the warranty claim form.

The limited warranty is not active until the installation sheet, included with the compressor manual, is properly filled out and returned. Failure to return the installation sheet will prevent the warranty from being active.

THIS POLICY IS LIMITED TO THE ITEMS ON THE INVOICE, WHICH IS ATTACHED WITH THIS DOCUMENT.



Quality Air Compressor at a Great Price.

600 S. 2nd Ave
Mansfield, TX, 76063
417-206-6353
800-531-9656