



600 S 2nd Ave
Mansfield, Texas 76063
1-800-531-9656 or 972-352-6363
Fax 972-352-6364
www.compressed-air-systems.com

Permanent Magnet motor screw compressor manual

Installation, maintenance and operation manual

Thank you for purchasing CAS PM series Screw Air Compressor

Thank you for purchase of PM Screw air compressor. This manual will help your better use of our strong air compressor system. And you are welcome to make suggestions and advice.

We try our best to ensure the completeness and correctness of the manual, but Compressed Air Systems LLC Company shall reserve the rights for continuous research and improvement on its products and assume no obligation for the modification and improvement on the previously delivered products. The design of products is subject to the change without notice.

Production license : _____
Model of compressor : _____
Serial number of compressor : _____
Model of motor : _____
Serial number of motor : _____

Preface

This manual describes the safety precautions, structure and functions of all systems and components , as well as the operation and maintenance methods for the PM series screw air compressors.

The operators shall read this manual carefully. Only after thorough understanding the structure and functions of all systems and components as well as the safety precautions, can they start operating and maintaining the unit. In addition to the descriptions in the manual, if the user fails to follow the operation and maintenance procedures in the manual for the operation and maintenance, or dismantles and modifies the machine by itself, or uses the parts not specified by CAS, the user shall loss the right for warranty claims.

There is no catalogue for the illustrations of parts and components given in the manual. If you want to order the parts from our company, please consult the part manual for related units. It is noted that CAS is continuously researching and improving its products and the contents of part manual may vary from the actual products after a certain period. Before you order the parts, please confirm it with the service (parts) department of our company in advance.

This manual gives a general description of the motor, electrical system and maintenance. However, if you have any questions before operating and maintaining the unit, please contact the local dealer or the service department of Compressed Air Systems LLC 1-800-531-9656

—— Editor

October, 2015

Safety Warning Signs

In this manual, the operations and items related to the safety are identified for their risks, and they are classified based on the severity of machine damages and the level of injuries caused due to the operations. They are represented and described in boldface with the following signs respectively.



“**Caution**” is meant to the unsafe factors which may cause the general damages to the machines or injuries.



“**Warning**” is meant to the unsafe factors which may cause property loss or the injuries.



“**Danger**” is meant to the unsafe factors which will cause the severe accidents or injuries.



“**Danger**” is meant to the unsafe factor which has the voltage exceeding the safety level to cause severe injuries. All electrical operations shall be performed by the qualified electricians.



“**Caution**” is meant to the unsafe factor which has the hot surface to cause the property loss or the injuries.



“**Caution**” is meant to the important installation, operation and maintenance information.

Safety Tips

Please read the following information carefully before operating and using the compressors



The risks are present in the compressed air and compressed air system!

If you fail to follow the operating procedures and safety precautions in the operation manual, there maybe accidents and injuries to yourself or other persons!

Before operating and maintaining the compressors, you must read carefully and understand the operating manual!

The detailed instructions are given to the safety precautions which shall be followed for operating the machines and the places with risks in the Chapter "Safety Rules". Before delivering the machines, the clear warning appliques have been attached to the places with risks and the places requiring careful operations.

1. Before any operations and maintenance on the unit, you **must** read and understand the operation manual.
2. It is **never allowed** to operate the unit above the rated air discharge capacity pressure of the unit. Otherwise, the overload will occur to the motor and it will be damaged.
3. Before the unit is delivered, individual protection controls shall be set in a good condition. It is **never allowed** to modify or remove the control components of the unit. Otherwise, the severe equipment damages and injuries will be cause.
4. When the unit is operating, it is **never allowed** to remove or loose any pipeline elements, joints and connectors and to move the safety valve. The unit is full of the pressurized thermal working medium, which can cause the severe injuries.
5. Prior to any maintenance on the unit, it **must** confirm that:
 - The unit is stopped;
 - The internal pressure in the unit has been discharged;
 - The power supply is shut off.
6. **Only** the safe solution is used to clean the compressors and the auxiliary equipment of the unit.
7. Once any parts are failed, they **must** be replaced immediately. Otherwise, the unexpected loss may be caused.

Content

Chapter 1 Safety Rules	8
Chapter 2 Introduction to System Functions	10
Chapter 3 Installation and Acceptance	19
Chapter 4 Operating Procedures	29
Chapter 5 Parameter Setting and Adjustment of Working Conditions	31
Chapter 6 Maintenance and Service	32
Chapter 7 Troubleshooting	43

Chapter 1 Safety Rules

1. General rules

The following listed safety measures and safety precautions are only a part of the items which have to be followed for operating the compressors and compressed air system, but are not complete.



Warning

If you fail to follow the following safety measures, the injuries, property loss or compressor damages will be caused.

Only the trained and authorized persons are allowed to operate the compressor. Prior to any operations, the operation manual shall be carefully read and its contents shall be comprehensively understood. If you fail to follow the operation and maintenance procedures and safety rules in the operation manual, the accidents and injuries are possible.

It is never allowed to start the unit in an unsafe condition; if the problems occur to the unit, don't attempt to start the unit. The power supply shall be shut off and the significant sign shall be given to prevent the person not knowing the condition from wrongly operating.

The compressed air is hazardous. Only when the compressed air is totally discharged in the whole compressor system, the maintenance and service can be performed on the unit.

Don't change the internal structure and control mode of the unit, unless the written permission from Screw Company is given.

The daily service and maintenance shall be performed well. The unit shall be carefully inspected every day to check if the conditions such as leakage, loose, damaged and poorly adjusted parts, or missed parts and components are present. If the problem is discovered, it shall be handled in time.

2. Common precautions

- 1) Before repairing the machine, all power supplies and any possible Long distance control devices shall be shut off, locked and identified.
- 2) If the unit is stopped, don't assume that it is safe. As the unit has the automatic starting and stopping devices, the starting is possible at any time.
- 3) The compressor is designed to compress the general air. Other gases or steams are not allowed to approach to the inlet of the compressor or to flow through the compressor.
- 4) The safety relief valves with proper size shall be installed in the system and shall be located before the suction valve, heat exchange, restriction orifice or any potential blockage points. If no safety relief valve is installed, the damages of compressor or compressor parts or the explosion may be caused.
- 5) Don't change the pressure setting of safety relief valve, or limit its function, or replace it with the plug. Otherwise the over-pressure will be caused to the compressor parts or system, consequently resulting in the injuries and property loss.
- 6) Don't use the plastic pipe, rubber pipe or the brazed connecting pieces in the compressed air system. If the matching between the compressor pipes and system pipes can't be ensured, the harmful noises will be caused.
- 7) Don't use the combustible or toxic solvent to clean the air filter or any components.
- 8) When the compressor is operating, don't remove any protection cover or outside board. It is prohibited to repair any parts in the unit when the machine is operating.
- 9) When the compressor is operating, it is noted to observe the meters and record, ensuring the normal operation of compressor.

-
- 10) Follow the stipulations in the maintenance and repair procedures and periodically inspect all safety devices, ensuring that they are in a good condition.
 - 11) It is never allowed to have the high-temperature protection switch (probe) with the short circuit, blockage or being removed.
 - 12) It is prohibited to play with the compressed air, to avoid the risks occur.
 - 13) Follow the maintenance and repair procedures and apply the proper lubricating oil.
 - 14) When the unit is operating, don't open the cover, to avoid the leakage of noise or the scald caused by the hot surface of the unit.
 - 15) Before installing the outside box, it shall ensure that no one is inside the unit.

3. Pressure releasing

- 1) Open the safety valve at least once every week and inspect whether the blockage or other damages is present. It is not allowed to pull the handle of safety valve when the unit is pressurized.
- 2) Confirm that the installed pneumatic equipment, air hose, pipe fittings, valves, filters and other accessories are in a good condition and the operating pressure during operation is not above the rated pressure.
- 3) Before opening the oil filling cap of oil-gas separator tank, the machine shall be stopped and it shall ensure that no pressure is present in the tank.
- 4) When removing any pipe fittings, valves, and oil drain plugs as well as the parts and components such as oil filters and oil-gas separator, it shall ensure that no pressure is present inside the system.
- 5) Don't operate against any air vents, regardless of the outlets of air supply pipes or the air vents of compressors or pneumatic equipment.
- 6) Only the compressed air with the pressure below 30 psi (2.1 bars) can be applied for dust removal. During the actual operation, the protection equipment such as dust protection cover shall be equipped. It is allowed to use the compressed air with the pressure above 3 bars for maintaining the element of air filter; but it shall ensure that the compressed air won't directly flow to the persons. The associated persons shall perform the necessary protections.

4. Operating components

- 1) The hands, arms and other body parts as well as the clothes shall not touch the operating components, such as coupling, fans and etc.
- 2) After the protection covers at the fan, coupling or other components are removed, don't operate the compressor.
- 3) During the operation, especially in the place near the high-temperature surface or operating components, the close clothes shall be worn and the long hair shall be tied up.
- 4) The door on the unit shall be closed unless it is for maintenance.
- 5) It shall be ensured that no one is inside the unit for starting it.
- 6) The lubricating oil shall be filled only after the machine is stopped.
- 7) It is possible to require adjusting the capacity regulating valve or pressure switch some time when the unit is operating. During the adjustment, don't touch other operating components and charged bodies. Other adjustments shall be made only after the machine is stopped.
- 8) The oil and water stains on the hands, feet, unit parts and the ground surface surrounding the unit shall be cleaned to prevent from slipping.

5. High-temperature surface, sharp corner and sharp edge

- 1) Don't touch the hot oil, lubricating fluid and high-temperature surface as well as the sharp edges and corners.
- 2) Any part of body shall not face the air vents of compressors and cooling fans.
- 3) When the operation or maintenance is performed inside the unit or surrounding the unit, the protection equipment such as gloves, helmets shall be worn.
- 4) The first aid box shall be equipped. The medical treatment shall be made immediately after the persons are injuries. Don't neglect the tiny cut and scald which may cause the infection.

6. Toxic and irritant substances

-
- 1) If the compressed air produced by the compressor is directly applied for respiration or food processing, then the severe injuries or death will be caused. The compressed air applied for the above purposes shall meet the stipulations in the OSHA 29 CFR1910.134 or FDA 21XDE178.3570 standard.
 - 2) Avoid the skin contact and swallowing the lubricating oil (fluid). If the skin contact is made inadvertently, then it shall be cleaned out with the soap water. If swallowing inadvertently, it shall turn to doctor immediately.

7. Hoisting

- . Prior to the hoisting, it shall carefully inspect individual connectors to check if the cracks occur at the welds of base, if the cracks, deformation or corrosion occur to the parts and components, and if the fasteners are loose.
- . It shall ensure that the selected hoisting equipment, hangers and riggings have a good performance and are able to withstand the weight of the unit. If the weight of the unit is not clear, it can weigh the unit or consult the local agent before hoisting.
- . The hoisting hook shall have the safety detent which can securely catch the lug or hoisting chain.
- . The unit shall be pulled with the rope to prevent the hoisted unit from turning or swinging.
- . Don't hoist the unit when the strong wind is present.
- . After the compressor unit is hoisted, no one can stand under it.
- . After it is hoisted, the hoisting operator can't leave the site.
- . The unit can be hoisted to a sufficient height instead of an excessive height.
- . When the unit is lowered, the supporting face shall have the proper hardness and strength.
- . Before transportation, the base shall be fixed with the iron nails or bolts.

Chapter 2 Introduction to System Functions

1. Introduction

The CAS PM screw compressor unit, is a positive displacement type, single-stage and oil-injected double-screw compressor. The motor is connected to the male rotor of compressor aircend via the belt or elastic coupling to drive the compressor rotating. The compressor aircend is originally imported with excellent processing, and therefore the unit has good dynamics, economical efficiency and reliability.

The unit has the proper layout, complete functions, simple operation and maintenance, and good appearance. The unit consists of the compressor aircend, air inlet system, air discharge system of compressor, cooling and lubricating system, air flow adjustment and control system of compressor, instrument control panel, electrical and automatic protection system and etc. In addition to the excellent acoustic absorbing material, the unit has the full-closed silent type design which can reduce the noises of the unit to the minimum extent. All instruments, indicators and control devices are centralized on the control panel for convenient operation; all components are installed on a high-strength steel frame for a long-term stable and reliable operation.

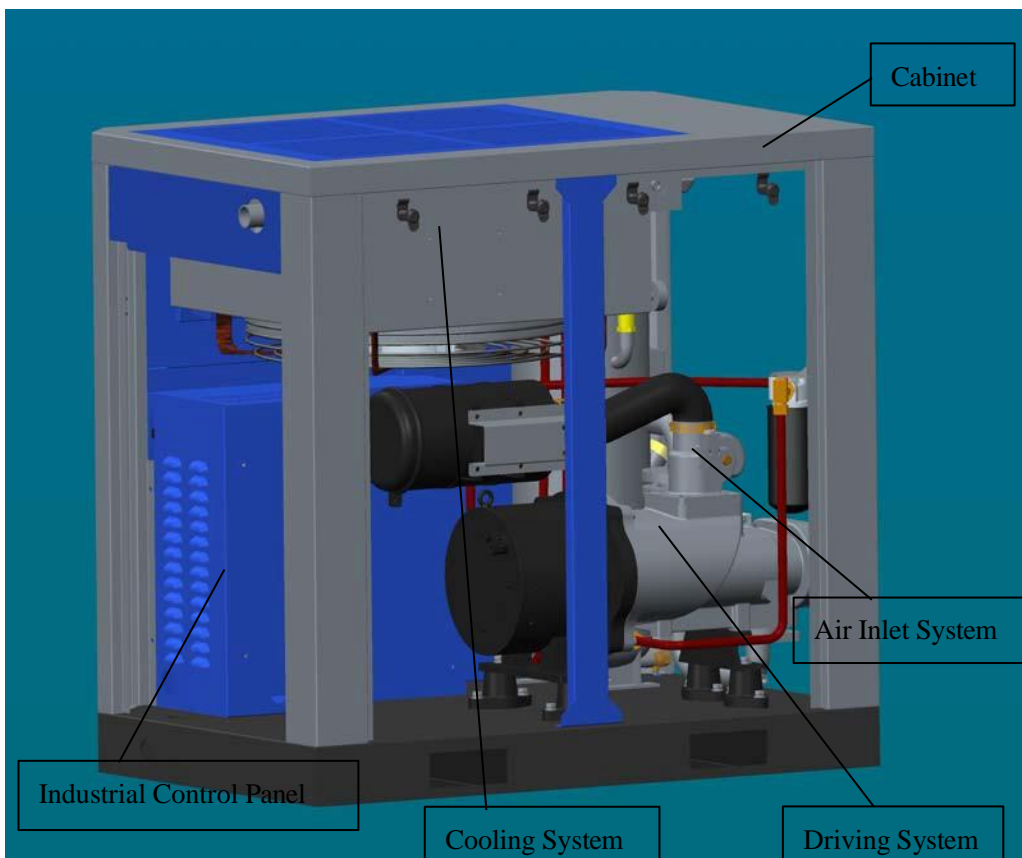

An illustration of a model is quoted in the manual for the description of the system. For the structure of other models, please refer to the quoted illustrations in the manual, as the structures and functions of individual systems are similar or alike. To maintain the best operating status of your purchased or applied screw compressor unit, please read the details in **Chapter 5 Maintenance and Service Procedures** in the operation manual. If you have the difficult problems which are not mentioned in the operation manual, please contact the local agent of CAS or the After-Sales Service Department of **CAS 1 - 800 - 531 - 9656**

Fig. 2-1 Introduction to the PM/EPM compressor system

2. Compressor airend and compression cycle

The compressor airend is a very important component in the screw compressor unit. The carefully designed single-stage oil-injected cooling and lubricating screw compressor can provide the stable compressed air without air flow ripple. Compared with other brand compressor airends, the unique property of the end selected by the Screw is the extremely high mechanical reliability and durability, and the working component achieves requirements of the “inspection-free” process. In addition, no frequent maintenance and internal inspection are required during operation.

In the outside box of compressor airend, there is a pair of parallel rotors (male rotor and female rotor) with spiral slots, which are finely processed. The air inlet and outlet are provided in the diagonal positions of the outside box at both ends of the rotors. The threaded slot of female rotor engages with the threaded teeth of male rotor, and it is driven by the male rotor. During operation, the air flows into the outside box via the air inlet at the power input end. When the rotor turns through the edge of suction hole in the outside box, part of suctioned air is trapped into the enclosed volume which is formed by the female and male rotors and the outside box. The closed volume of threaded slot changes with the engaging movement of the female and male rotors, and consequently the continuous operation cycle for suction, closing, compression and discharge will be realized. The compressed air will be discharged via the air vent and then enter into the oil-gas separator.

3. Air inlet system

See Fig. 2-2, the function of air inlet system in the compressor unit is to provide clean air to the compressor. It includes **an air filter, a suction valve and connecting pipeline**. At the outlet of the air filter, a vacuum pressure switch or vacuum indicator is installed.

The air filter adopted in the unit is the dry heavy duty filter, which can be used in the extremely severe operating environment to handle the very dirty air, ensuring the normal operation of the compressor. In addition to the main filter core, there is a cyclone separating blade ring outside the main filter core in the outside box. It can pre-filter the relative coarse dust particles. The operators shall frequently remove the dust particles accumulating in the dust bag at the rear cover of air filter. When the vacuum pressure switch in the air filter acts or the vacuum indicator turns to red, it indicates that the flow resistance in the air filter is too high and the main filter core shall be maintained or replaced in time. In addition, some models have a safety filter core, which has the function for temporary protection in a short-term in the case that the main filter core is damaged. The safety filter core usually requires no maintenance and shall be replaced only while the main filter core is replaced.

 **Caution: The aperture of safety filter core is larger than that of main filter core. It only has the function of temporary protection in a short term (4-6 hours) after the main filter core is failed. Therefore, once it is found that the main filter core is failed, it shall be replaced immediately. Otherwise, it may cause accidents such as the worn of the compressor rotors, damaged bearings and etc.**

The connecting elbow of the air inlet system adopts the high-quality molded rubber pipe fittings, which have the properties of relatively good cold resistance, heat resistance and aging resistance. To ensure reliable sealing, all the joints in the air inlet system of the unit shall have the stainless steel T-type bolt clamp for connection.

 **Warning**

Never use the iron wire to tie the rubber pipe fittings or use the rubber pipe fittings with cracks.

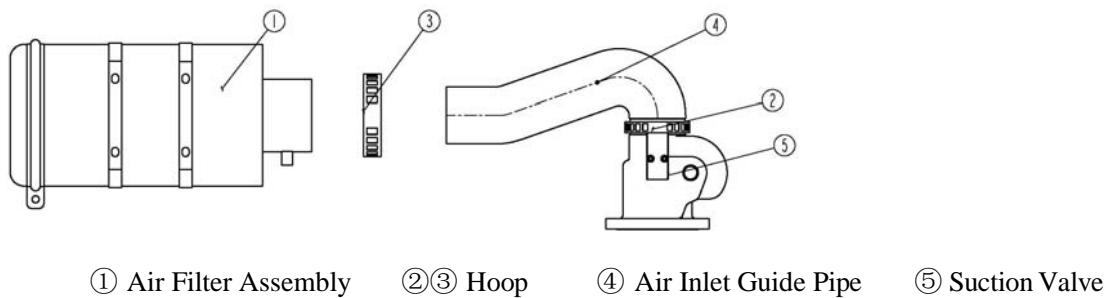

Fig. 2-2 Air inlet system

4. Air discharge system of compressor

The air discharge system of compressor unit mostly consists of **air discharge pipe, oil-gas separator, minimum pressure valve, safety valve, after-cooler** and etc. See Fig. 2-3.

When the compressor is operating, the air inside the closed room of threaded slot is continuously compressed and the heat generated in the air during the compression is absorbed at the same time by the lubricating oil which is continuously injected into the closed volume of threaded slot. When the closed volume of threaded slot is reduced to a certain value (designed value), the closed volume of threaded slot is connected to the specially designed air vent, and the mixture of oil and air is discharged out of the air vent. As the pair of rotors in the screw compressor have several threaded slots and the rotating speed of rotors are very high, the air discharge of the unit is continuous.

The mixture of oil and air discharged from the compressor airend enters into the oil-gas separator. Most oil is separated from the air by the catching, collision and direction change in the separator. The formed oil drops accumulate to the relative large particles which will fall into the lower part of the tank by the gravity. Only some very fine oil mist is left. When the air flows through the filter core of oil-gas separator, the oil mist will congeal to the fine oil drops on the fibers of filter core by the collision, dispersion and catching. The oil drops congealing on the outer fibers of filter core will fall to the oil level in the lower part of the cylinder by the gravity, while the oil drops congealing on the inner fibers will finally be collected in the bottom of filter core. A secondary oil return pipe is led from the bottom of filter core and connected to the suction chamber of compressor. The oil accumulating in the bottom of filter core will flow back to the suction chamber of compressor under the action of pressure differential. The throttle orifice is installed in the oil return pipe. The throttle orifice is confirmed by test and will ensure both the stable oil return and the minimum air loss. Therefore, the modification is not allowed unless it is permitted by Compressed Air Systems LLC.

A minimum pressure valve is installed in the downstream of the outlet of oil-gas separator tank and its function is to ensure that a minimum tank pressure will be established in the tank when the compressor is normally operating, ensuring the normal operation of the lubricating oil circuit. When the unit is stopped or unloaded, the minimum pressure valve acts as a check valve to prevent the return flow of compressed air. The unsealing pressure of minimum pressure valve is 4.0 ± 0.34 bars (60 ± 5 psi), which has been pre-set before leaving factory.

The compressed air after oil-gas separating only contains several PPM (usually below 3PPM) lubricating oil. After the separated compressed air flows through the minimum pressure valve, it will enter into the after-cooler for cooling down and then can be used by the users.

The after-cooler is applied to reduce the discharge temperature of compressed air and consequently make most of water in the compressed air condense and separate, reducing the water content in the compressed air and avoiding the problem caused by water content in the downstream air.

Due to the different cooling method, the after-cooler is classified into two types: air cooling and water cooling. The air

cooling after-cooler is connected to the oil cooler to be integral. The fan drives the cooling air to flow through the surface of cooler for cooling.

The water cooling type after-cooler and oil cooler usually are connected in series. The cooling water flows through the after-cooler at first and then enters into the oil cooler.

A safety valve is installed on the cylinder of oil-gas separator tank. When the pressure inside the tank exceeds the setting pressure of safety valve, the safety valve will automatically open. The unsealing pressure safety valve is set before the delivery. Please do not change it by yourself. A temperature sensor is additionally installed in the air discharge pipe. When the discharge temperature of compressor exceeds 110°C (230°F), the unit will automatically stop.

The screw-plug of oil filling port in the oil-gas separator is specially designed and can release the possibly remained pressure in the tank when it is removed. The oil sight glass installed on the cylinder is applied to inspect the level of lubricating oil in the tank. When the machine is not operating, the normal oil level shall be located between the center of oil sight glass and its top position.

⚠ Warning

- **When the compressor is operating or pressurized, do not remove the nuts, oil filling cap and other parts. Before maintenance, the machine should be stopped and all internal pressure should be released.**
- **It is not allowed to replace or use the safety valve with other models.**

5. Cooling and lubricating system of compressor

The lubricating oil in the system has the following three main functions:

- A) It acts as the coolant. The injected lubricating oil can absorb a large amount of the heat generated during the compression, and consequently control the temperature rise of compressed air.
- B) It fills the leakage clearances between the rotor and outside box and between rotors, reducing the internal leakage of compressed air and increasing the efficiency of compressor.
- C) The lubricating oil film is formed between rotors. It allows the male rotor to directly drive the female rotor and can absorb some mechanical noises at the same time.
- D) It's used to cool down the oil cooling PM/EPM motor.

See the flow chart in 2-4. Generally, the cooling and lubricating system of compressor consists of **oil-gas separator, oil cooler, oil filter and oil pipes**, etc. The cooling fan is controlled by inverter, the inverter will automatically control the fan motor speed according to the setting temp. in the PLC in order to maintain the constant temp.

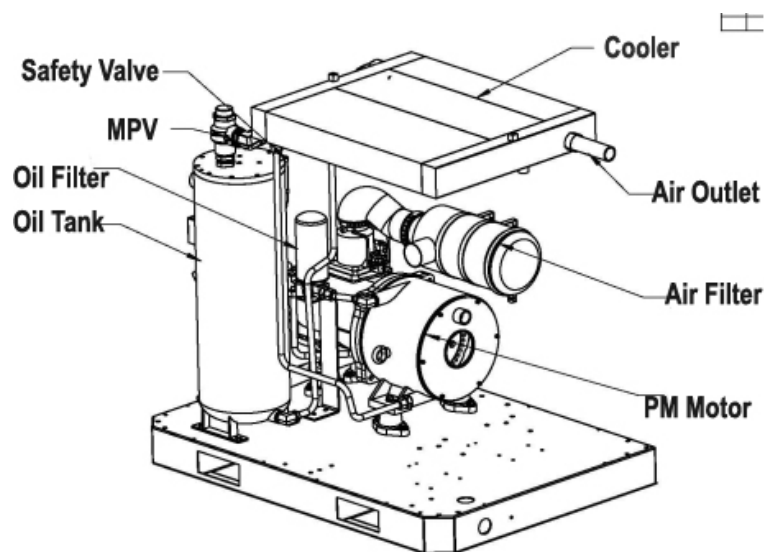

Fig 2.3 Compressor Cooling and Lubricant System

The **oil filter** consists of filter base and replaceable spin-on filter core (depending on the size of model, there may be two or three filter cores) with built-in by-pass valve which will ensure the unblocked oil circuit and normal operation of compressor in case that the filter core is dirty or the viscosity of oil is too high.

The **oil cooler** is an important part in the cooling and lubricating system. Due to different cooling methods, it can be classified into two types: air cooling and water cooling. The brief description is given below.

Air cooling type oil cooler: the cooler has the aluminum plate-fin type structure. The cooling fan forces the air to flow through the fins of the cooler and cool down the lubricating oil in the pipes of cooler. To maintain the normal operation of compressor, the radiating fins of cooler shall be kept clean and the maximum operating ambient temperature of compressor shall not exceed 43°C. During the daily maintenance, the surface of cooler shall be periodically cleaned. If necessary, the high-temperature pressurized water not above 3.5 bars can be applied to wash it.

Water cooling type oil cooler: the water cooling type oil cooler has the shell and tube type structure. The lubricating oil flowing in the shell transfers most heat via the pipe wall to the cooling water flowing through the pipes. Similar to the air cooling model, the lubricating oil flows through the thermostatic valve first and then enters into the cooler for cooling down, ensuring that the unit operates in the normal temperature between 80~95°C (176~200°F).

6. Air flow adjustment and control system of compressor

This series PM compressor is equipped with standard automatic control system.

For compressor below 100HP, as long as you press “Start” button, it will start to load, according to the line pressure, it will adjust frequency automatically to produce the compressed air which match up with the air consumption.

When the system pressure reach unloading pressure (normally, it's VF pressure+0.6BAR), It will force the suction valve to close, the compressed air inside oil/air tank will be released out completely, the compressor will stop automatically.

The compressor will enter into standby mode. When the system pressure reduce loading pressure (Normally, it's VF pressure -0.7BAR), the compressor will start automatically.

For >100HP compressor, there have two option: manual control and automatic control. Customer could select loading or unloading under manual control mode. When automatic control is selected, the compressor will continue work and produce the required air relying on the differential pressure regulator. When the pressure reach unloading pressure (normally, it's VF pressure + 0.6BAR), the controller will send message to make the suction valve close, and release all the compressed air inside oil/air tank, the compressor keep running, but don't produce compressed air. The timer is triggered, the compressor will enter into countdown of unloading, after the end of the time cycle, the compressor will stop automatically and enter in to “Standby” Mode. When the line pressure decrease to loading pressure (normally, it's VF pressure+0.7BAR), The controller will send “Start up” Message, the compressor will start up automatically.

Please refer to Fig. 2-4 for system flow.

For ≤100HP PM/EPM compressor, the compressor have three working mode: A. Start up Mode, B. Stop Mode, C. Standby Mode.

For >100HP PM/EPM compressor, The compressor have four working mode: A. Start up mode, B. Loading Mode, C. Unloading mode, D. Stop & Standby Mode.

The compressor parameters have been set well in the factory, there's no need to set parameters for client, unless the working condition has changed, and it will need authorized people to re-set the parameters.

The compressor take use of controlling the degree of opening of the intake valve to control the amount of intake air of the compressor in order to achieve the purpose of adjusting the volume. There are four working status: A. Start up condition; B. Loading condition; C. VSD control condition; D. Standby condition. The following nominal pressure 8bar (116psi) models were introduced as an example of its working principle.

Warning

Do not think if the compressor is not operating, then the maintenance operation on it will be safe, as the compressor may be in the “Standby” status and can start at any time. Please strictly follow all related stipulations in “Maintenance and Service Procedures”.

6.1 Working conditions of starting

For >100HP compressor: Press the start button, the motor VSD start up, the compressor suction valve opens a small amount of air at the moment the action of vacuum. At this point, solenoid valve 1,3 port held in communication, while vent valve is opened so that the oil/air tank is vented state, instant boot small amount of air sucked through the solenoid valve into force it to close the intake valve, the intake valve plate holes (or the valve plate and the valve body between a small gap) allow a small amount of air into the compressor, making it essential to maintain the pressure within the 1.5-3.5bar (22-51psi) range. The compressor start up with light load. Solenoid valve and vent valve is closed, the intake valve fully open, compressor loading operation, the system pressure rapidly rise to 4.0bar (60psi).

For \leq 100HP compressor: press the start button, the motor VSD start up, the compressor intake valve opens in an instant vacuum effect, the machine enter into a loading state

6.2 Loading State

When the system pressure exceeds 4.0bar (60psi), minimum pressure valve opens, the compressor start to discharge compressed air out. The suction valve is fully open, the compressor work at loading state. Subsequently, the system pressure will soon reach the rated pressure, the unit enters normal operating conditions. Unless the customer air consumption is changed, the compressor will run continuously in this state.

6.3 Working at adjustment state

When air consumption is less than the rated displacement, the system pressure will rise. When the pressure exceeds the rated pressure of 0.01 to 0.02Bar, The inverter will reduce frequency to reduce the motor speed. If the time of the compressed air demand increases, the pressure within the oil/air tank will drop. When the pressure drops below the rated pressure set value, the inverter frequency increases, so the compressor run at full capacity again.

6.4 Unloading & Stop State

For > 100HP compressor: When the customer air consumption continues to decrease to 20% less than the nominal displacement compressor, line pressure will exceed PLC setting 8.6bar (125psi), this time, the compressor will turn into unloading state, relying on a small amount of the intake valve bypass pipe intake air pressure is maintained within the unit 1.5 ~ 3.5bar (22-51psi) range to ensure that the internal oil lubrication system oil circulation. Within this pressure range, minimum pressure valve is closed, the compressor will run at a unloading state.

For \leq 100HP compressor: When the line pressure exceeds the PLCS setting 8.6bar (125psi), The PLC will send stop message, the compressor will stop running, enters into standby state.

For > 100HP compressor: If air consumption increases, the line pressure drop. When the pressure is lower than 7.3bar (106psi), the PLC will send loading message, the solenoid valve will be activated and the vent valve will be closed, the compressed air inside oi/air tank will stop releasing, the suction valve will open, so the compressor will enter into loading state automatically .

For ≤ 100 HP compressor: When the line pressure is lower than 7.3BAR(106PSI), the PLC will send start message to start up compressor again.

7. Electrical system and automatic protection

See Fig. 2-6. Electrical system is the system which realize compressor start, stop, parameter display and automatic protection. The system includes the motor, industrial control panel, instrument, contactor, transformers, cables and terminals, inverter and various protection switch etc.

 **“Caution”:** The related documents are attached when the unit leaves factory. To avoid mis-operation, please refer to the electrical schematic diagrams attached to the machine for the maintenance and service of electrical system.

Standard oil-cooling motor is totally enclosed, protection grade is IP54, maximum ambient temperature is 43 °C (110 °F). This standard does not apply to saline, corrosive, dirty and wet and explosive situations.

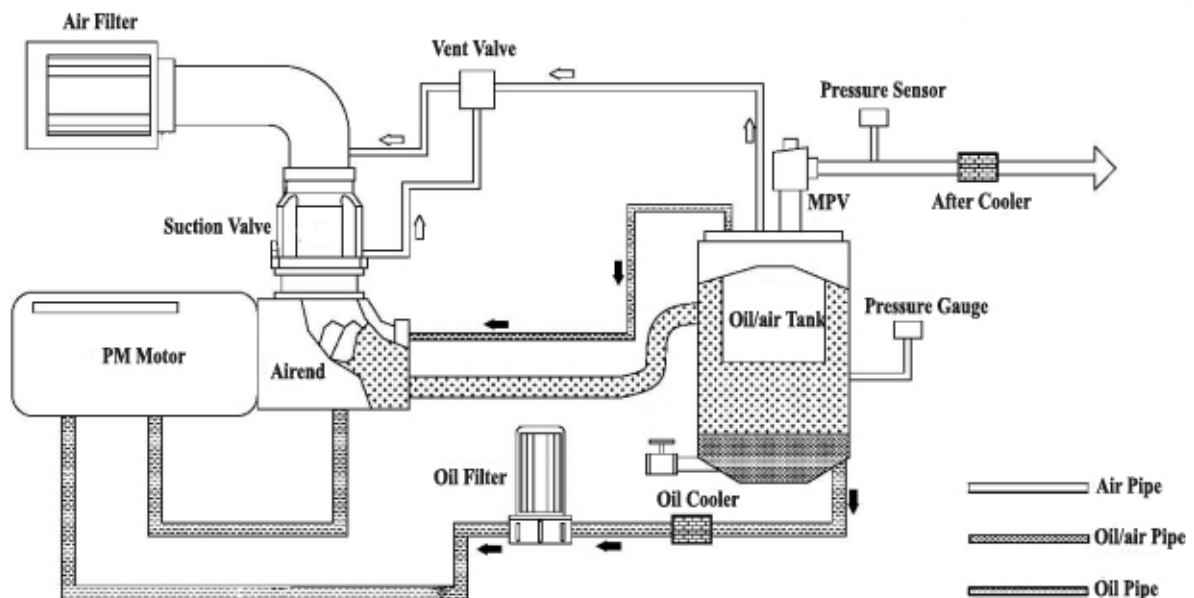

Fig. 2-4 System Flow

- Automatic protection is an important part of the compressor. Its role is to ensure that the compressor is not under normal circumstances, then it can not start or will stop automatically, and thus play a security role for the aired and the motor. The features include: Compressor discharge temperature shutdown protection, high pressure shutdown protection, motor overload protection, motor short current protection, lack phase protection etc. When the compressor operate normally, in addition to the safety valve, other automatic protection devices can make the compressor stop, when these unexpected situation happen,the compressor will stop automatically, and send fault

message.

 **Warning:**

High voltage will cause severe injury and death. Please cut down the power supply before maintaining the electrical apparatus or opening the electrical control box.

 **Warning**

Do not remove, bridge, or damage the high-temperature safety switch. If the safety function is not provided, severe injuries, death and property loss may be caused. If the machine is shut off due to the over-high temperature, please contact the qualified service persons immediately.

Chapter 3 Installation and Acceptance

1. Installation, acceptance and storage:

In the process from the delivery of machine to the installation in position on site, the correct shutdown maintenance and service contribute to the completion and normal operation of equipment. Therefore, the machine shall be inspected immediately for the damages caused during transportation when it is received. If the damages are found, the carrier can be required to sign on the shipping document and give the damage report. If the damages are not found in time and then the hidden damages are found afterwards, please inform the carrier within 15 days after receiving the goods and require the carrier to give the damage report. The detailed report is very critical for handling the damages (claim).

Check the nameplate of compressor to ensure that it has the model number and specifications you ordered and check whether optional parts are included. In addition, inspect the oil-gas separator and safety valve to confirm whether the design or pressure setting is correct. The protection and maintenance solutions shall be prepared for the unit which will not be installed temporarily or operated for a long term, ensuring the normal operation of the unit, especially the air end of main machine.

The handling and installation of unit shall strictly follow the precautions related to handling after the packaging box is opened. Two holes for fork lifter are set under the base of unit. When it is lifted, the supporting block shall be placed to prevent the fork lifter from crushing the door plate of unit (shown as the figure). If the lifting rope is used, the cross bar has to be applied, which can counteract the lateral pressure against the box caused by the lifting rope. Note: It is not acceptable to place some protection materials between the lifting rope and the outside box of unit. It will crush the door plates at both sides in the top of unit.

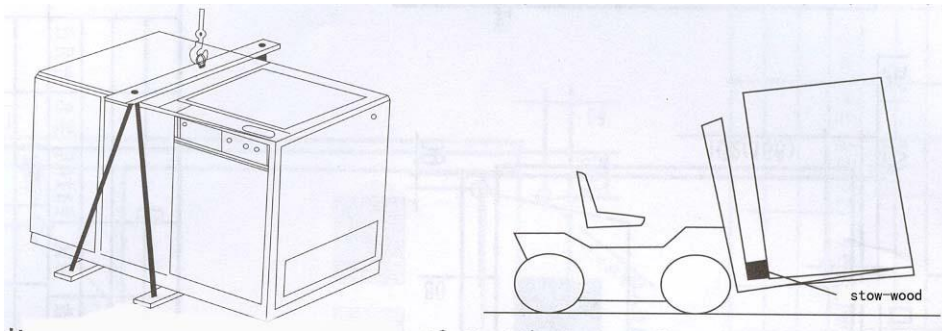

Fig. 3-1

2. Installing and locating

The series of compressor units are applicable to the indoor environment. Place the compressor in a clean environment with good lighting and ventilation, and the foundation shall be solid and flat. The whole base shall tightly fit the horizontal level of foundation. If necessary, the hard rubber cushion can be shimmed. However, it is noted that no wood wedge is used. For the safety and simple maintenance as well as the daily inspection, the sufficient space shall be provided around the machine (At least 1.2m space shall be left around and above the compressor).

The operating ambient temperature of compressor can't exceed 43°C (110°F). Otherwise, the compressor will be shut down due to over-heat. The spatial dimensions and shape of compressor room shall be carefully considered, to prevent the hot air discharge capacity by cooling fan from circulating in the machine room and consequently causing the rising of

operating ambient temperature. In principle, all stationary type screw compressors from Screw are provided for indoor installation and application. The modified ones can also be installed in the outdoor places. The machine cover shall be water-proof and not sealing, preventing from rainwater, snow and freezing.



The compressor can't operate in the environment with the temperature below 0°C (32°F) or above the maximum operating temperature limit.

Do not place the compressor in the environment where it may suction the high-temperature waste gas discharged by other compressors or thermal load equipment. Do not block the cooling air discharge capacity of the air cooling compressor, and it shall be guided to the outdoor, avoiding the excessive ambient temperature in the compressor room. If the ventilation in compressor room is poor, the high-temperature shut-down of machine may be caused. Moreover, don't place the compressor in the basement or the places with poor ventilation. If the possibility of oil pollution caused by the water is considered, the operating temperature of compressor shall be controlled and the lubricating oil of compressor shall be monitored.



The normal operation of compressor requires sufficient cleaning air.



Removing or modifying the outside box will cause the high noises and consequently be harmful to human health.

The screw compressor has a stable operation and basically no vibration. It can be naturally placed without anchor connection. However, if it is necessary for the user, the compressor can be fixed with bolts to prevent the pipes from breaking or prevent the electrical connection from being damaged due to the displacement of machine caused by the collision. In this point, it is noted that the bolts shall not be tightened excessively to prevent the oil cooler, pipes and air tank from cracking and being damaged due to the distortion and deformation of machine base caused by the excessively tightened bolts.

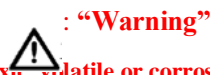

Do not install or expose the compressor to the places with toxic, volatile or corrosive gases. It is also not allowed to store the substances with similar properties around it. Otherwise the severe injuries and property losses will be caused.

If the working condition for operation is relatively poor and there are much dust, then the specially configured heavy duty air filter shall be added to maintain the service life of air compressor system and parts.

Please refer to relevant regulation for Design of Compressed Air Station.

3. Storage and maintenance of the unit

The screw compressor unit is specially designed, especially for the air end of main machine, which is precisely machined and formed. The operating procedure and requirements from the manufacturer shall be strictly followed for the maintenance and service. Otherwise, the property losses and injury accidents may be caused. If the unit will be stored for a long time or will be out of service for a long period, then it shall ensure at first that it is placed in a clean and dry environment. The accumulated water in the bottom of the parts and components such as oil-gas tank, cooler (especially the water cooler), steam-water separator, pipeline water filter shall be drained out. Individual major parts and components

of unit and joints shall be inspected periodically and clean them to ensure no leakage and rust signs. It shall start and operate for at least 60 minutes every month to ensure the safe lubrication in the airend of main machine. Secondly, the careful inspection is required before it is started. If necessary, the lubricating oil shall be replaced in the unit. In addition, 2-hour operation test shall be performed at full load on the unit and the data shall be recorded. The qualified specialized service engineer shall be present for instruction.

4. Pipe connection

No lead/tin solder is allowed in the connection of pipes or connecting pieces. The lead/tin solder materials have the characteristics of low strength and can't resist the high temperature. Their melting point is only 182°C (360°F). Therefore, please don't mistake them for braze welding such as the silver solder and copper solder. In addition, please note that no plastics, PVC, ABS pipes or rubber hoses are allowed in the piping system for compressed air.

It has to be noted that no rusty pipes will be installed on the compressor. The pipes shall be connected to the proper position without bending and distortion. To avoid the effect of heat expansion of the pipes on the system, some flexible expansion joints or hoses can be installed in the system, if necessary. The pipes shall be independently supported and fixed to reduce the vibration and prevent the expansion and deformation. In any cases, the size of pipes shall be no less than the connection size of discharge pipes in the compressor.

For the compressor, the cleaning air is critical. The air filter is indispensable. The air supply which can supply the cleaning air shall be selected. If the outdoor air supply is used, then it shall ensure that all pipes are short and straight. The pipes shall be properly laid out and the vibration shall be avoided. The diameter of pipes shall be no less than the dimensions of suction valve. For the excessively long pipes, the diameter of pipes shall be increased. In addition, the pipes shall prevent from leakage and shall be absolutely clean after they are installed.

4.1. Points for attention in piping, base and cooling system

4.1.1 Points for attention in piping of air pipeline

- 1) For piping of main pipeline, a 1 to 2 inclination degree is required to facilitate the discharge of condensation water in the pipeline.
- 2) The pressure drop of the pipeline shall not exceed 5 percent of the setting pressure of the air compressor so it's recommendable to select pipes with a larger diameter than the design diameter during piping.
- 3) The branch pipeline must be connected to the top of the main pipeline to prevent the condensation water in the pipeline from flowing down to the machine or flowing back to the air compressor.
- 4) A combination of three devices including water filter, pressure regulator and oil feeder shall be installed on the tools that require lubrication to maintain their service life.
- 5) Don't reduce the size of the main pipeline randomly. If the reduction or enlargement of the pipe is required, a reducing pipe must be adopted or the mixed flow may occur at the connection which will lead to a bigger pressure loss and also exert a great influence on the service life of the pipeline.
- 6) If such clean and buffer facilities as gas holder and dryer are available, the ideal piping shall be air compressor + gas holder + dryer. In this way, the gas holder may eliminate part of the condensation water and also have a function of decreasing the exhaust temperature. The air with low temperature and less moisture will definitely ease the load of the dryer.
- 7) If the system requires both a large volume of air and a short time, it's recommended to install a gas storage barrel for buffer to reduce the times of transition from no-load to working load, which may benefit a lot to the

air compressor.

- 8) For the compressed air whose system pressure below 1.5MPa, the speed in the transmission pipes must be less than 15m/s to avoid excessive pressure drop.
- 9) The number of bends and all kinds of valves used in the pipeline shall be as small as possible to reduce the pressure loss.
- 10) The ideal piping is to make the main pipeline go around the whole plant so the bilateral compressed air is available at any position. The pressure drop may be cut down in case that the air consumption jumps high in a certain branch pipeline. The annular main pipeline shall be equipped with appropriate valves to cut off during servicing.
- 11) When too many air compressors are parallel connected, you'd better set a pipe check valve for each compressor to avoid confusing of the air.

4.1.2 Base

- 1) The base shall be built on the rigid soil. Before installation, the ground shall be made horizontal to avoid any vibration of the air compressor.
- 2) If the air compressor is installed upstairs, the vibration protection shall be made to prevent the vibration from transmitting to downstairs or to prevent the resonance. It's crucial to the security of the air compressor and the building itself.
- 3) For the swirly air compressor, no base is required thanks to its slight vibration but the ground on which it's installed must be flat and the soil mustn't be soft soil.

4.1.3 Cooling system

- 1) For those water-cooling air compressors, soft water shall be used as the cooling water to avoid chemical reactions due to such ions as calcium and magnesium in high temperature. The reaction may form scale on the cooler, which jeopardize the heat exchange of the cooler. If the cooling water tower system is adopted, the softening agent must be added regularly to maintain the clean water quality.
- 2) The self-feeding system of the cooling water circulation system shall be improved or after a certain period of operation, the cooling water quantity may be insufficient which will cause the tripping of the air compressor due to the high temperature.
- 3) The pressure of cooling water is maintained usually at 3 to 6BAR.
- 4) Special attention shall be paid to the ventilation environment if the air compressor is air-cooling type. The air compressor mustn't be placed near high-temperature machines or in a air-tight space with bad ventilation to avoid tripping due to over high exhaust temperature. If the compressor runs in a air-tight system, exaction and exhaust equipments must be added. Generally speaking, the single air rate of exaction and exhaust must exceed the exhaust rate for heat dissipation of the air compressor.

5. Installation of safety facilities

- a) Safety valve (relief valve)

The safety valve is a pressure relief device with proper size, which is applied to protect the system. It has been set before delivery. It is not allowed to change its pressure setting at random or block the valve. Only the manufacturer of safety valve or qualified agent can perform such operation.

The safety valve shall be located before the potential blockage points, including (but not limited to) the check valve, heat

exchanger and discharge silencer. In theory, the safety valve shall be directly connected to the pipes or vessels which bear the pressure, instead of being connected via the pipes. The discharged gas from safety valve shall be led to the safety place far away from the people.



Do not modify, weld, repair or reprocess the pressure vessel with GB (or ASME) specifications. No operation exceeding the ratings on the nameplate is allowed. Otherwise, the warranty clause will be influenced and the severe injuries and property losses will be caused.

b) Protection cover

All mechanical movements have the risks in different levels. Therefore, the protection covers shall be installed. The series of units completely follow the national and industrial standards to have the necessary protection facilities. The user shall periodically inspect and maintain them and no random modification or removal is allowed.

c) Manual vent valve and shutoff valve

It is recommended to install a manual vent valve in the air system of customers. The purpose of installing the manual vent valve is to discharge the air in the compressor and its air discharge capacity pipes to the atmosphere. If the air tank in the system is used with a single compressor only, then the vent valve can be installed on the air tank. If the shutoff valve is installed in the system, the manual vent valve shall be installed in the upstream side of shutoff valve. However, the safety valve shall be installed in the upstream side of manual shutoff valve. Such a configuration can ensure that the persons and equipment are in a safe status during maintenance and service.

If the compressor is isolated from the system only for the maintenance, please note not to replace the shutoff valve with the check valve.



Before maintaining the machine, the manual vent valve has to be opened to release the pressure in the compressor and system. The neglect in the pressure reduction of system may cause the severe injuries, death and property losses.

6. Electrical installation

Before installation, it shall be inspected whether the capacities of power supply, power supply wires and transformer are consistent. The proper fuse or breaker shall be configured in the installation. The unbalance between the voltage phases shall be limited to be within 5%, to prevent the over-current caused due to low voltage. For installing the motor and connecting the electric wires, cables and all electrical elements, the related national electrical standards and local regulations shall be followed. Only the qualified electricians can perform the above-mentioned operations. The grounding of compressor shall be in a good condition. See the electrical wiring diagrams.

7. Water supply and drainage (water cooling type)

Ensure the unblocked connection of water supply and drainage pipes. The water path and pipeline configured by the user shall have at least the same diameter as the water path in compressor unit. The drainage equipment shall have the simple installation and connection. The local drainage standard and the requirements from the compressor shall be met. It shall be absolutely ensured that the connection of water supply and drainage pipes are correct.



“Caution”: The water temperature regulating valve is located in the water discharge pipe.



“Warning”

Removing or covering the safety signs will cause the status without indicating information and then it may cause the injuries or property losses. The warning signs shall be outstanding and placed in the significant position with good lighting. In addition, the text shall be clear and it is not allowed to move the warning signs and other attached indications.

8. Adjustment of coupling

The alignment of coupling shall be inspected and corrected after the placement of machine is completed by the user for the series of compressors. That job is essential and critical. The connection deviation of coupling shall be corrected to be within the allowable range before the machine is started. Each time the machine is moved, then that job shall be performed, ensuring that the failures such as efficiency reduction, shortening the service life and increasing the noise will not be caused due to the alignment problem of coupling. The adjustment methods for the coupling are as follows:

- Required tools: micrometer gauge, vernier caliper, measuring tape, steel-plate straight ruler, small mirror, several clean shims with the thickness of 0.025mm-0.5mm, recording sheets, crowbar, etc.
- Preliminary calibration: See Fig. 4. The preliminary calibration has two functions: one of them is the rough calibration to allow the micrometer gauge to achieve the measurement (because the measured value can't exceed the range of micrometer gauge; otherwise the micrometer gauge will be damaged); the other is to adjust the motor shaft to be slightly lower than the compressor shaft, so that the final calibration requires to add the shims only. As shown in the figure, place the straight ruler on the coupling flange edge of compressor shaft. The vertical distance between the straight ruler and the coupling flange edge of motor shaft is adjusted to be within the range of micrometer gauge. Adjust the shims on the support legs of motor or directly lower the motor to a certain position, to adjust the above distance to be within 1mm.

Turn the motor shaft and adjust it again to allow the above distance to be within 1mm. Repeat the adjustment as the above several times.

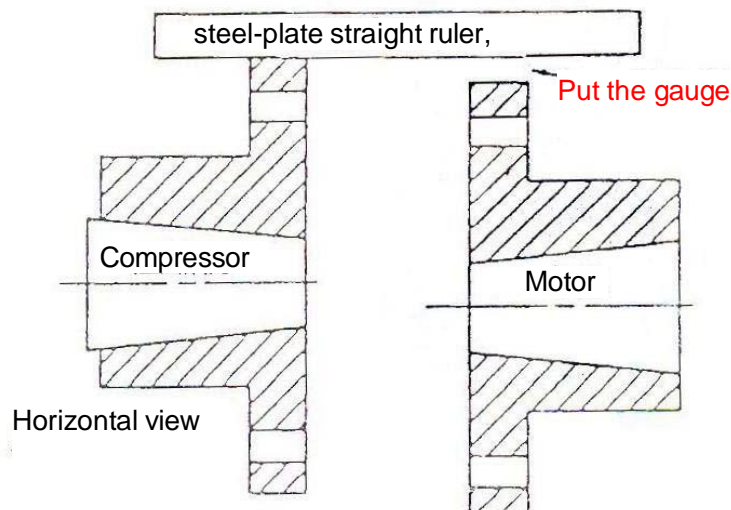

Fig. 4 Preliminary calibration

- c) Fine calibration: As shown in Fig. 5, use a small vice or loop chain to fix two micrometer gauges on a half-coupling, or use the magnetic micrometer gauge base. Move a probe to the slight upper position on the end face of the other half-coupling, to measure the angular deviation; move the other probe to the center of external circumference of the coupling, to measure the coaxiality deviation. It needs to ensure that the measuring surface is clean and has no coating; adjust the micrometer gauge and press down the probe in a midway to allow it to be able to move in two directions.
- d) Reset the micrometer gauge to zero at the N point in Fig. 5.
- e) Turn the compressor shaft with the motor shaft for 360 degrees (one turn). During the turning, it shall be ensured that the probe is fixed on the flange. After one week, the micrometer gauge shall return to the zero position. If the micrometer gauge doesn't return to the zero position, then inspect the installation conditions of micrometer gauge, and inspect the tightening condition of small vice or loop chain or the adhesion condition of magnetic block. Afterwards, try again. During the turning, it is best to allow the coupling to be connected or partially connected, which will be helpful for turning the compressor shaft with the motor shaft, as shown in Fig. 6.
- f) At first adjust the parallel and then adjust the coaxiality (Please note: for the positive and negative values of the number of micrometer gauge, the symbols shall be given in the calculation). Reset the micrometer gauge to zero (0.000mm) at the N point in Fig. 5. Turn the compressor shaft with the motor shaft, and record the readings of two micrometer gauges every 90 degrees (1/4 turn). A group of readings are shown in Fig. 5. As two shafts turn together, the position of micrometer gauge relative to the shafts is not changed and then it will eliminate the deviation caused due to the irregular rim or end face. The mirror can be used for easily getting the readings. Generally, a group of readings can't account for a lot. Several groups are necessary. Confirm whether the readings are consistent.
- g) In the example shown in Fig. 5, the deviation from the micrometer gauge for angular measurement is 0.000mm at N point and becomes -0.152mm at S point; it indicates that the tail end of motor is higher (relative to the compressor). The total angular deviation (T.I.R) is 0.152mm. The calculation of the distance required for the motor adjustment is described as follows:
- 1) Measure the revolving diameter D of the probe of "angle" micrometer gauge (relatively smaller than the diameter of half-coupling). It is assumed to be 152mm in that example.
 - 2) Measure the distance L between two mounting bolts in the front and rear of motor. It is assumed to be 750mm.
 - 3) In this example, the angular deviation (T.I.R.) M in the vertical direction was just now measured to be 0.152mm.
 - 4) It assumes that the thickness of shim to be inserted or removed is S.
 - 5) The thickness of shim can be calculated as per the following formula: $S = LM/D$. Then
 $S = 750 \times 0.152 / 152 = 0.75 \text{mm}$

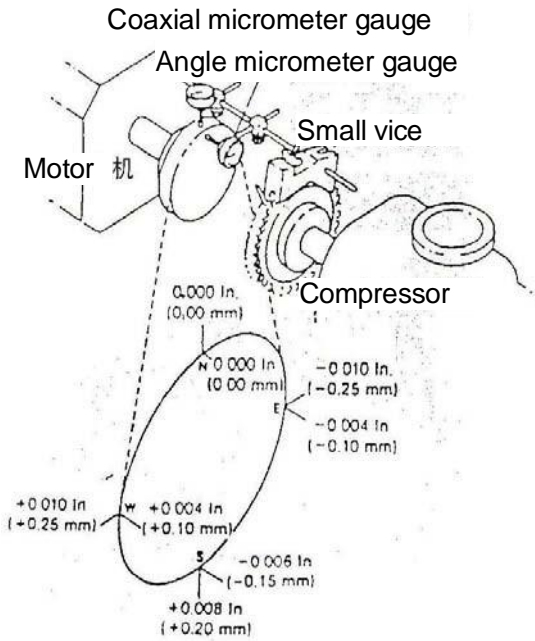

Fig. 5

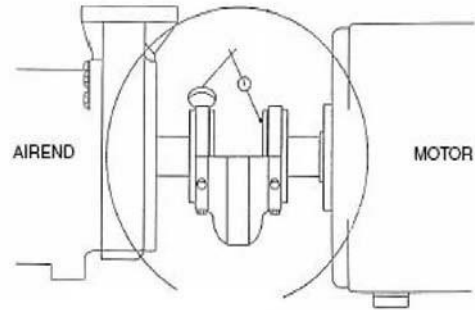

Fig. 6

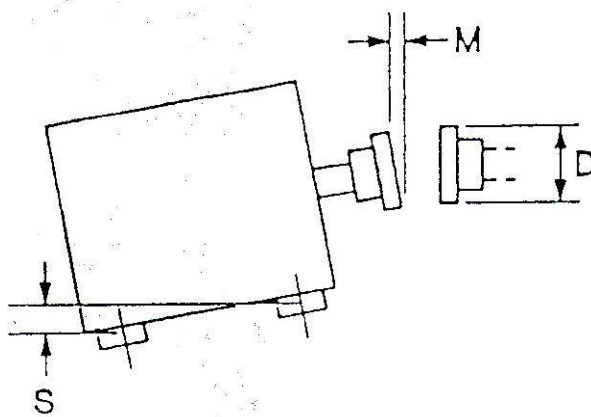

Fig. 7

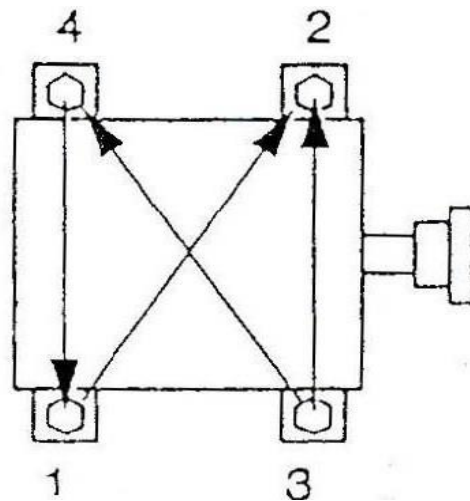

Fig. 8

h) According to the above calculation, it is necessary to remove the shim with the thickness of 0.75mm from the support leg in the tail end of motor. For operation, the motor is lifted by the crowbar or hoisting equipment, as shown in Fig. 7. After the adjustment is completed, tighten the mounting bolts as per the order shown in Fig. 8. After the mounting bolts are tightened, use the micrometer gauge to inspect whether the error is within the controlled range.

9. Mounting and dismounting for PM/EPM motor

9.1 Installation for PM/EPM motor

1. Mounting stator---Put 0.1mm copper sheet in.

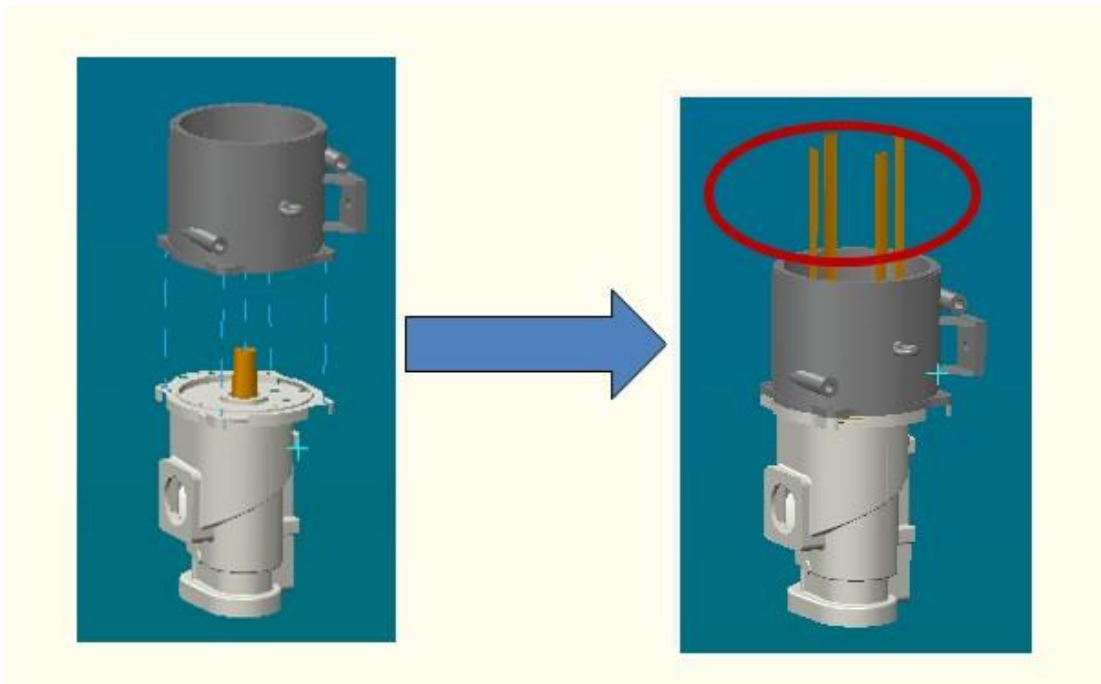

2. Put in Motor Rotor--- Fix bolt and check whether the air gap is regular.

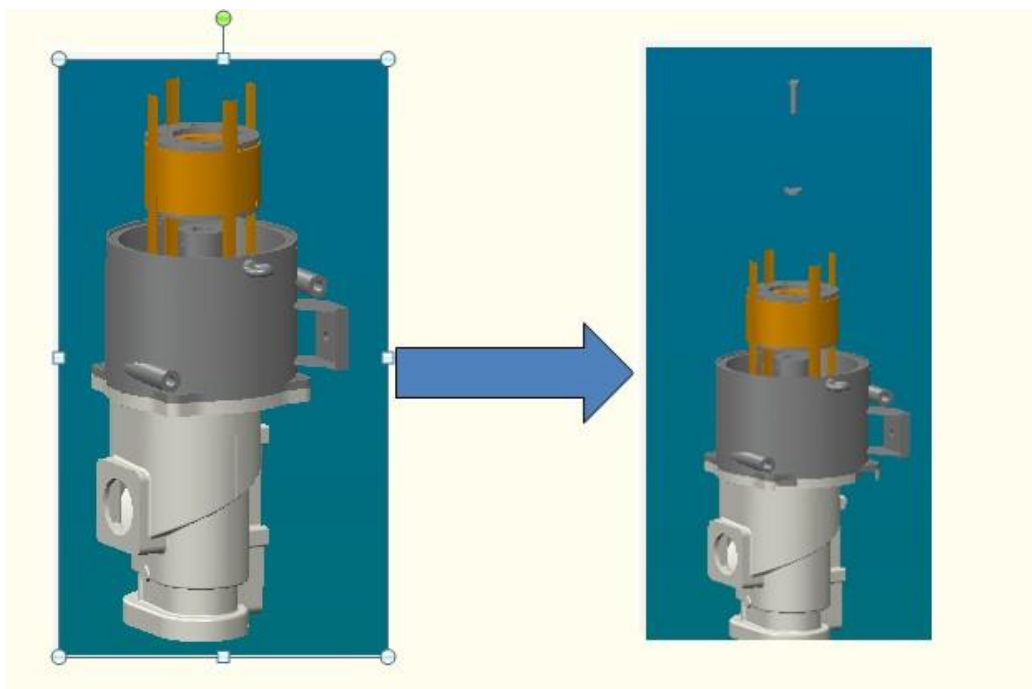

9.2 Dismounting for PM/EPM motor

1. Put in Copper Sheet---- Remove stator

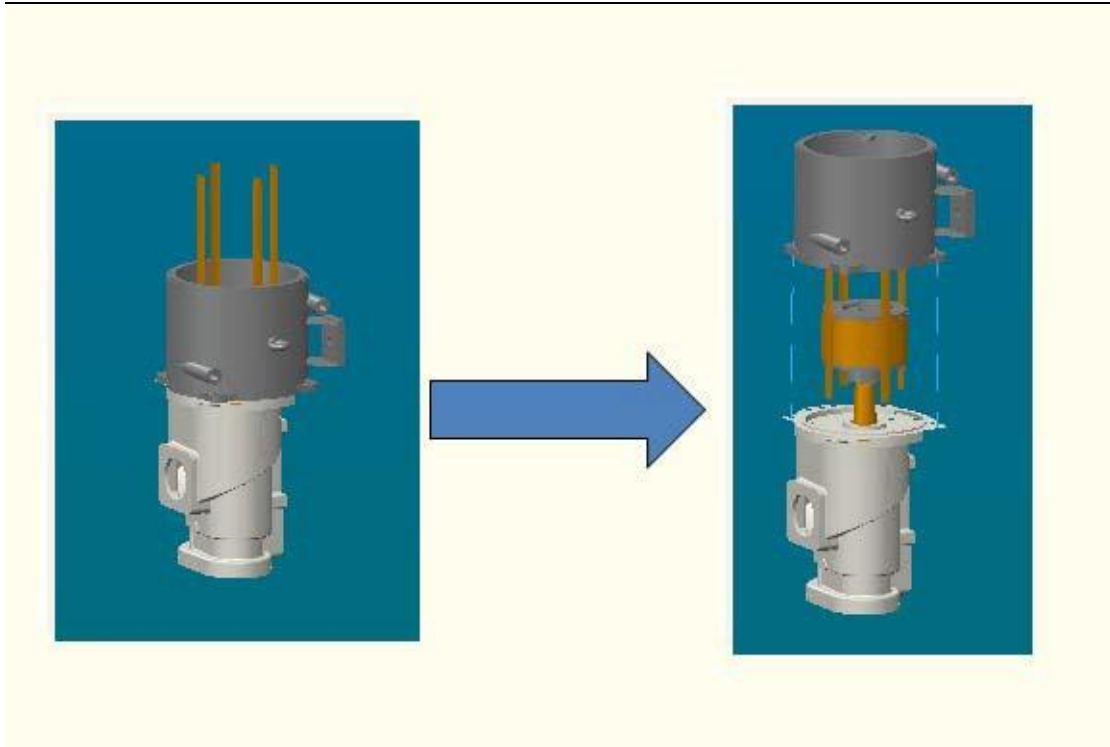

2. Loose rotor and remove it.

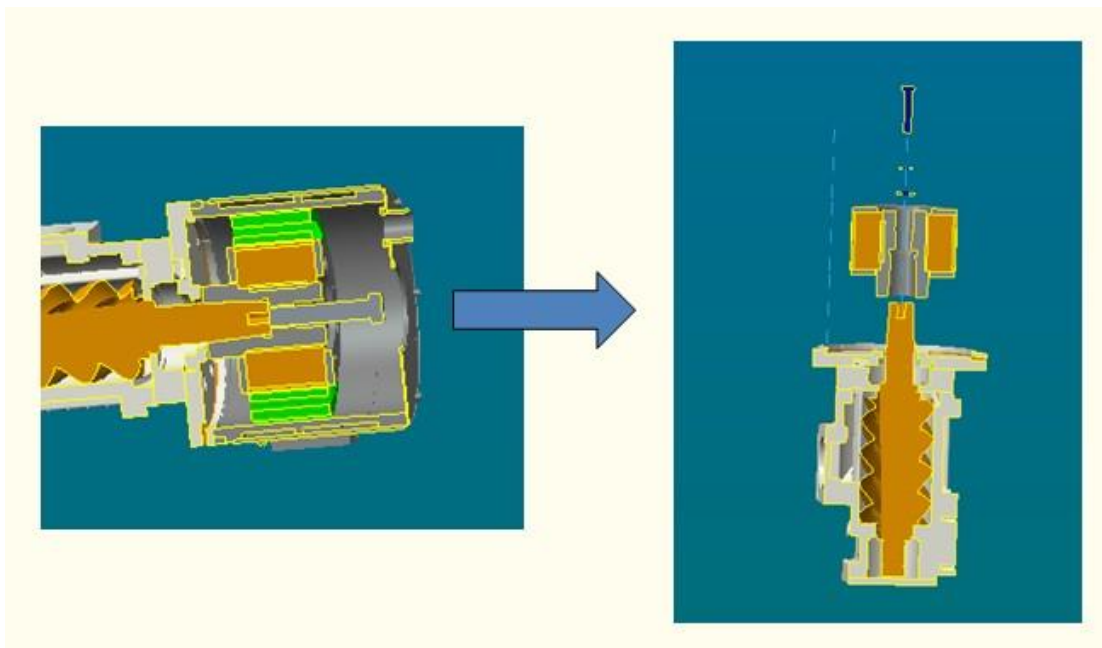

⚠: “Warning”

Please don't dismount PM/EPM motor unless it's professional technician, The PM/EPM motor has strong magnetism, please don't let your electronic device like cell phone or electrical device to close it. It's forbidden for the people who use heart pacemaker to dismount and fix it. It's necessary to make sure the clean surface of motor rotor, not any metal particle has been absorbed at the surface.

Chapter 4 Operating Procedures

1. Overview

The PM/EPM compressor are equipped with a series of control elements and display/indicating elements. To ensure the normal operation of compressor, it requires the operators to properly operate the machine. In addition, it requires that the operators can have a proper judgment against the operating status or failure conditions of the unit according to the displayed/indicated values or states. Before the unit is started, the operators shall be familiar with the positions, functions and usages of the control/operating elements and display/indicating elements. See PLC operation manual for details.

2. Preparation for the starting

- 1) Remove the foreign materials and tools around the compressor.
- 2) Remove the fixing bolts on the basis platform of the motor and air end.(noticed by a label with a red arrow)
- 3) Inspect the oil level to ensure that it is in the normal position (See the sections for lubricating oil).
- 4) If necessary, inspect the alignment of belts or coupling.
- 5) Inspect the fan to ensure that it is mounted firmly.
- 6) Manually turn the machine to ensure that no mechanical interference occurs.
- 7) Inspect whether all joints for pressure pipes are secure and not loose.
- 8) Open the suction valve.
- 9) Inspect and ensure that the safety valve is installed in position.
- 10) Inspect whether all covers and protection devices are safe and secure.
- 11) Inspect whether the specifications or control current setting of the fuse, breaker and thermal overload protection device is proper and the setting are correct.
- 12) For the water cooling unit, inspect the water inlet and discharge pipes and ensure that their connections are correct and secure and that the cooling water is turned on.
- 13) Inspect whether the air filter is securely installed.
- 14) Close the power supply switch, and then the indicator light for power supply will be lit. Inch the starting button and inspect the rotational direction of compressor to ensure that it is consistent with the specified rotational direction.

3. Regular starting steps

- 1) Open the shutoff value going to the air supply system.
- 2) Pre-set the control parameters and then push the starting button.
- 3) Observe whether the started compressor has the abnormal vibration, noise and air/oil leakage. If the problem is found, please immediately shut down the machine and correct it.
- 4) Close all external cover doors to control the noises of the unit and ensure the normal flow of cooling air.
- 5) Slowly close the air supply shutoff valve. Inspect whether the unit is unloaded as per the setting. **See the Section 1 Setting Procedure in Rated Working Conditions in Chapter 6.**
- 6) Inspect whether the indicating values of status parameters are normal.
- 7) For the water cooling unit, please inspect the inflowing water pressure. Adjust the ball valve in the water circuit to allow the discharge temperature of unit to be kept in the normal range.
- 8) In the first hour since the compressor operates, please carefully observe the operating conditions. In the following seven hours, observe it at any time. If the abnormality occurs, please shut down the machine for repairing.
- 9) After the primary operation, shut down the machine as per the shutdown procedures. Inspect whether it is necessary

to add the lubricating oil into the oil tank; inspect whether the joints are loose.



“Caution”

- ① **It is necessary to discharge the condensate water in the bottom of oil-gas separator periodically. The operation for discharging the condensate water shall be performed before starting the unit.**
- ② **It is necessary to discharge the condensate water in the bottom of filter in the control pipes periodically (every week). The operation for discharging the condensate water shall be performed before starting the unit.**

4. Shutdown procedure

- 4.1. Push the stop button.
- 4.2. Close the shutoff valve connecting to the air supply system.
- 4.3. Disconnect the power supply switch.



“Caution”: Closing the shutoff valve for shutdown can avoid that the compressed air of air supply system is returned to the compressor due to the damages of check valve and then the leakage and damages of machine parts will be caused.

5. Emergency shutdown: In the abnormal case, push the emergency stop/resetting switch to shut down the machine, and disconnect the power supply switch.

Chapter 5 Parameter Setting

Please refer to the PLC Manual.

Chapter 6 Maintenance and Service

1. Preparations before maintenance and service

To ensure the normal operation and long service life of the unit, the good maintenance and service are critical. Therefore, the maintenance and service procedures for the screw compressor unit shall be carefully performed. Before proceeding the maintenance, please carefully read the Chapter 1 **Safety Rules** in the manual. **The following preparations are required at least:**

- 1) Shut off the power supply of main machine and hang the sign at the power supply switch.
- 2) Close the shutoff valve going to the air supply system to prevent the compressed air from returning to the maintained parts.
- 3) Open the manual vent valve to release the pressure in the system. Keep the vent valve in the opening status.
- 4) For the water cooling machine, the water supply system has to be shut off and the pressure in the water pipes shall be released.
- 5) Ensure that the compressor unit has been cooled down to prevent from scald and burning.
- 6) Wipe off the oil and water signs on the ground to prevent from falling.



“Warning”

- **Do not think that the maintenance and service operations can be performed when only the machine is shut down. The automatic control system of machine will start the compressor at any time.**
- **The poor maintenance and service will influence not only the normal operation of unit, but also the safety of operators.**
- **When the compressor is operating or pressurized, don't remove the nut, oil filling plug or other parts.**
- **It is not allowed to use the combustibles solvents, such as the gasoline or kerosene oil, to wash the air filter or other parts and components. The safe solvents shall be applied as per the instructions.**

2. Maintenance and service of screw compressor



“Caution”: Only the trained and qualified maintenance persons have the qualification to perform the maintenance and service on the machine.

2.1 Lubricating oil of compressor

The screw air compressor designed can use the **RS8000** oil listed in the below table. Every delivered compressor unit has a lubricating oil tag to indicate the type of lubricating oil filled in the unit. The different types of lubricating oils are adaptive to the different ambient temperature and load conditions and the oil-changed interval is also different. Only when the specialized synthetic lubricating oil from Screw Company is used, then the corresponding warranty service can be obtained.

Type of lubricating oil	Oil-changed interval (hour)	Ambient temperature °C
RS8000	4000	≤43°C

For the compressor unit with standard configuration, the RS8000 lubricating oil is generally added for the delivery. The

lubricating oil is the specialized oil for the screw compressor, which is provided specially by the manufacturer. It can provide the reliable operation and a long change interval.

Do not mix the oils with different types or trademarks for application. Otherwise, the operation failures such as the lubricating oil foaming, filter blockage, orifice or pipe blockage will be caused, reducing the designed service life of compressor and lubricating oil.

When the machine is operating, please inspect the level of lubricating oil periodically. The oil sight glass is installed in the oil-gas separator in each unit from Screw. The normal oil level is located in the green area of oil sight glass. If the oil level of oil-gas separator lowers to the red area of oil sight glass after the machine is shut down, then adding the oil is required for the unit. However, only when the machine is shut down and thoroughly drained out, the oil can be added.

2.1.1 Factors influencing the service life of lubricating oil

- 1) Abnormal high operating temperature
- 2) Contamination:
 - a) Other types or brands of lubricating oils
 - b) Strong oxidizing substances, such as
 - ❑ Acid
 - ❑ Sulphur
 - ❑ Chloride
 - ❑ Nitrogen oxide
 - ❑ Welding waste-gas
 - ❑ Ozone
 - c) Ammonia water
 - d) Solution type fume
 - e) Airborne dust

Place the compressor in the ventilation and cool place as far as possible, ensuring that it can operate within the normal temperature range. Otherwise, the oil consumption of compressor and oil content in the air will be increased. In addition, if the operating temperature exceeds 95°C (203°F), the service life of lubricating oil will be halved every time the discharge temperature increases by 10°C (18°F). Therefore, it is better that the operating temperature of the above lubricating oil doesn't exceed 95°C (203°F).

2.1.2 Lubricating oil analysis plan

CAS can provide oil analysis service. The oil analysis inspects the total acid value (TAN), viscosity and other indices of lubricating oil in the compressor and provides the users with the best oil-changed interval, protecting the compressor equipment of customer to a maximum. The general oil analysis plan is recommended as follows. Consult the agent or the service department of CAS for the related details.

Caution: The oil sampling shall be stopped when the compressor is operating. It is best to take the sample from the interface of oil filter. It will exactly reflect the current quality of lubricating oil.

- ❑ New machine is started and operate for 600 hours;
- ❑ Operate every 2000 hours;

-
- When the abnormal conditions such as the high oil consumption, oil leakage at shaft seal, and air end locking occur.
 - If necessary.



The high-temperature and high-pressure lubricating oil can cause the severe scald and even the injuries. During the operation or when the pressure is present in the compressor, it is prohibited to open the oil filling plug. If the oil addition is required, then confirm at first that the equipment is in the shutdown state and the power supply of system is shut off so that the equipment is not possible to automatically start.

2.1.3 Water discharge and replacement of lubricating oil

The condensate in the bottom of oil-gas separator tank shall be removed periodically. If the water content in the lubricating oil exceeds 200PPM, the lubricating oil will be severely emulsified and consequently the damages of the air end and bearing will be caused. Therefore, it is necessary to replace the lubricating oil. It is prohibited to mix the lubricating oils with different types or brands for replacement. Otherwise, the warranty clause for the compressor unit will be invalid. If it is necessary to use other types of lubricating oils due to the special conditions, please contact Screw agent or Screw service department.

2.2 Oil filter

After the new machine operates for 600 hours, the element of oil filter shall be replaced. Afterwards, it is required to replace the oil filter when the following conditions occur. For replacing the filter core, the machine shall be shut down. Wipe off the dirt and oil from the outside carefully and prevent the foreign matters from entering into the lubricating system as far as possible.

- In the normal operating temperature, the filter (pressure differential) has an alarm. In this point, the pressure differential of filter exceeds 1.7 bars (25 psi).
- Every time it operates for 1000 hours.
- When the lubricating oil is replaced.
- When the oil sample is assayed to be disqualified.



“Caution”: In the cold morning, the indicating light may be lit after the air compressor starts, due to the high pressure differential caused by the low fluidity of lubricating oil. Please monitor the indicator after the operating temperature of compressor is normal.

When the signs are present to show that the insoluble deposits are formed on the element of oil filter, it indicates that the lubricating oil in the compressor can't operate normally and it shall be replaced immediately.

The replacement and adjustment steps for the element of oil filter are as follows:

- ① Use the band type wrench to remove the old filter core and shim.
- ② Clean the mounting surface of shim.
- ③ Apply a thin layer of lubricating oil on the surface of new shim.
- ④ Tighten the filter core by hand for 1/2 - 3/4 turn.
- ⑤ Start the machine again and inspect whether the leakage occurs.

 **Warning**

- To reduce the possibility of the damages of filter core to a minimum, only the products provided by Screw Company can be used, because other substitutes may not match the pressure in the unit.

2.3 Safety valve

If the dirt blockage occurs in the safety valve, it will cause the safety valve not to be opened or not to be automatically closed after it is opened. If the safety valve fails to open, then its function to protect the pressure system will be lost to have no safety assurance of unit. If the safety valve fails to close, then the accident that the lubricating oil in the oil-gas separator will be injected in a great amount, and consequently the property losses will be caused. The machine shall be shut down every week for inspecting the status of safety valve.

2.4 Secondary oil return pipe

The function of secondary oil return pipe is to guide the oil accumulating inside the filter core of oil-gas separator to return to the low-pressure chamber of compressor. Its orifice is applied to ensure the stable oil return. If the severe blockage occurs in the secondary oil return pipe (mostly in the orifice and filter), then the oil content in the discharged air will be excessive. The secondary oil return pipe shall be inspected in the specified time. Clean the orifice and filter (if equipped).

In the daily maintenance, if the following conditions occur, then the orifice shall be cleaned:

- Fail to see the lubricating oil to flow through the oil sight glass.
- It is found that the oil content in the discharged air is too high.
- Every time the lubricating oil is replaced.
- Once every half a year.

2.5 Oil cooler

When the oil, grease, dust and dirt accumulate onto the surface of cooler, the heat transfer effect of cooler will be reduced and finally it will lead to the excessive discharge temperature. For the air cooling cooler, the external surface of cooler shall be cleaned every other two months with the dust cleaner, cleaning fluid or low-pressure (usually not above 3.5 bars) compressed air. For the water cooling cooler, the discharge temperature shall be monitored in real time. In the general operating conditions, the interior of cooler shall be cleaned every 8,000 hours or a year, whichever comes first.

2.6 Air filter

The air filter shall be inspected every day.

Every day, the dust-collecting bag shall be cleared (for heavy duty air filter), and the dust cap or air inlet silencing chamber shall be cleaned. In the dusty environment, the cleaning operations shall be more frequent. If it is very dirty in the environment, it is recommended to arrange the air inlet of compressor to the place with clean air supply in the outdoor.

Every time the vacuum switch of air filter acts, or when the pressure loss reaches 25" water column, or when the indicator is lit, the filter core shall be maintained. When it operates every 500 hours or 3 months, the air filter shall be inspected for

the damages and the air inlet system shall be inspected for the sealing; in the normal operating conditions, the element of air filter shall be replaced every 2000 hours or a year. If the environment condition is poor and dusty (such as ceramic, cement and etc), the maintenance and replacement intervals shall be properly shortened. For the heavy duty filter, when the main filter core is replaced, the safety filter core shall be also replaced. The safety filter core requires no maintenance during the operation.

Every time the air filter is maintained, it shall be inspected whether the downstream side of filter core is dirty. If so, the causes shall be found and eliminated. It is necessary to ensure the air tightness of sealing elements, thread connection, flange connection and leather hose connection between the air filter and the air inlet of compressor are absolutely secure.

The maintenance and replacement steps for the filter core:

- ① Remove the rear cover and clear off the dust in the dust pan.
- ② Carefully take off the main filter core. Visually inspect whether the filter paper is damaged, the adhesion of rubber sealing pad is secure, the adhesion between metal end cover and filter paper is secure and the crack occurs to the metal end cover.
- ③ Use the clean wet cloth to clean the inner side of outside box. Please note that no compressed air is allowed.
- ④ After Slightly tapping the end face of filter core on the flat plate, use the dry compressed air not exceeding 5.88 bars (85 psi) to blow off the dust in each wrinkle of main filter core from insides to outsides along the direction 45 degrees to the longitudinal direction of filter core.
- ⑤ Re-install the cleaned filter core or new filter core in position. Please note not to forget the sealing ring under the retaining nut of filter core. The nut shall be properly tightened. If it is too loose, then it can't ensure that the sealing washer fits tightly the end face of outside box. If is too tight, then it will easily cause the deformation and disengagement of end cover of filter core.
- ⑥ Install the dust pan and rear cover. Please note that the opening direction can't be mistaken.



“Caution”: When the compressor is operating, it is not allowed to remove and replace the element of air filter. It is prohibited to use the oil, water or the compressed air containing water to clean the filter core. The filter core with damaged filter paper or sealing ring shall be replaced immediately. Every time the filter core is installed, the whole circumference of end face of the sealing ring in the filter core shall be applied with a little grease, to prevent the adhesion between the sealing ring and the outside box of air filter.

2.7 Oil separator

The element has an overall structure and can congeal the oil mist on its surface to become the oil drops which will fall into the bottom of separator and then be recovered by the oil return pipe to return to the compression chamber. The separator has to be carefully handled to avoid the damages. Once the element of separator is hit and deformed, even an indentation will influence the separating efficiency, consequently resulting in the excessive oil content in the discharged air of compressor. Even a tiny hole on the component will lead to very high oil content.

In the normal case, if the air filter and oil filter are maintained in a good condition, then the periodic replacement of filter core in the oil-gas separator will not be required.

If the following conditions occur to the machine, then it will be required to replace the element of oil-gas separator:

-
- The pressure differential switch of separator acts and the pressure differential between the front and rear sides exceeds 1.0kg.
 - In the case that the oil level, loading and unloading, and the oil return system are identified to be normal, the oil content in compressed air is still too high.
 - Every other 4,000 hours

The detailed replacement and adjustment steps are as follows:

If the supplied air contains the oil significantly and the filter, check valve, orifice and the diaphragm of vent valve in the oil return pipe are inspected in a normal condition, then it is necessary to replace the filter core of oil-gas separator.

- ① Remove all pipes (oil return pipe, air supply pipe and etc.) connected to the flat cover.
- ② Remove the oil return pipe (stainless steel pipe) from the joint on the flat cover.
- ③ Remove the bolts and washers on the flat cover, and take off the flat cover.
- ④ Remove the filter core.
- ⑤ Clean the sealing surface between the flat cover and cylinder. It is noted not to allow the chips and dust to fall into the cylinder.
- ⑥ Replace the new filter core. It is noted **not** to remove the staple from the shim.
- ⑦ Install the flat cover and tighten the bolts by hand. Then diagonally tighten the bolts in 4-5 steps. The tightening torque is referred to the standards of Screw Company.
- ⑧ Re-connect all pipes. The stainless steel oil return pipe shall extend to the position 1.5mm away from the bottom of filter core of oil-gas separator to maintain the unblocked oil return.
- ⑨ Before restart the machine, clean the filter, orifice and check valve in the oil return pipe .
- ⑩ After operating for 24 hours again, tighten the bolts on the flat cover as per the requirements in Step 7.

2.8 Maintenance of minimum pressure valve

See Fig. 6-1. Only after the pressure in the machine is released, then the maintenance is allowed.

1. Remove the valve from the top of oil-gas separator tank;
2. Screw off the top cover and remove the main spring;
3. Reverse the valve. Use the screwdriver to tap the check valve assembly until the piston and check valve assembly disengages;
4. Clean the valve body and undamaged components;
5. Apply a layer of oil on the new check valve. Gently place it into the valve body. Install a new non-return spring;
6. Apply a layer of oil on a new O-ring. Install the piston and a new piston spring. Re-install the top cover in position.

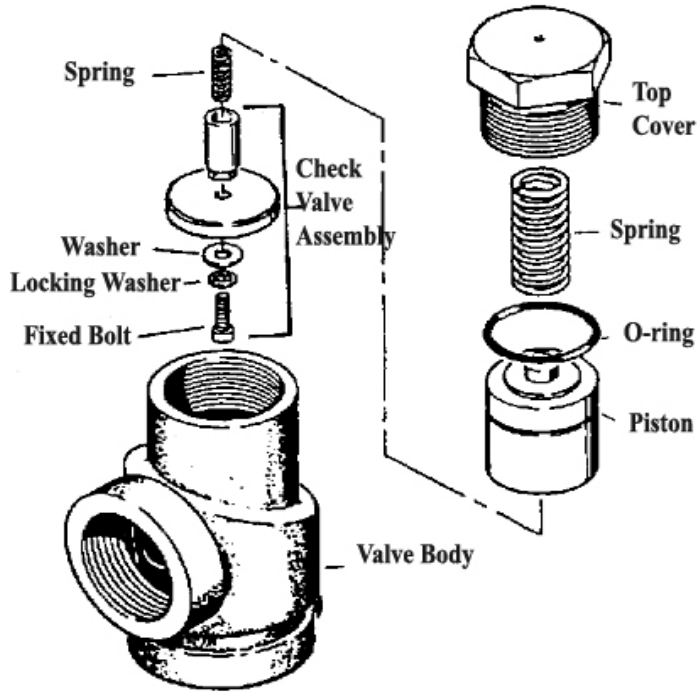

Fig 6-1 Minimum Pressure Valve

2.9 Maintenance and replacement of thermostatic valve

The purpose of thermostatic valve is to make sure the compressor running temp. will be not lower than pressure dew point, which is the guarantee for long span-life of airend and compressor. It's combined by Valve body, Thermostatic valve core, O-ring. If you notice the following phenomenon, it's necessary to do inspection for compressor:

The running temp. change frequently, and the change range is higher than 5°C.

The running temp. is too low, especially when the discharge temp. is lower than 70°C at winter time.

The running temp. is too high, especially when the discharge temp. is higher than 95°C at normal condition.

2.10 Hose

When it operates every 600 hours or half a year, it is necessary to inspect the air supply hose, lubricating oil pipeline and the flexible hose in the control pipeline. If necessary, replace them.

2.11 Installation of shaft seal

The shaft seal of compressor is a wearing part and will be replaced sooner or later. The shaft seal can be successfully replaced when the specialized tools are equipped and the installation process and operating procedure are thoroughly understood. If you decide to perform it by yourself, please require the complete diagrams, operating process and maintenance notes from Screw agent or Screw Company.



“Caution”: When a suspected shaft seal is removed, don't damage it. The damaged part of sealing element shall be noted and observed to obtain the causes for the damages of sealing element.

The Compressor is equipped with an oil return pipeline to match the shaft seal assembly, so that the whole shaft seal has the triple-sealing function. The oil return pipeline shall be inspected for the maintenance and replacement of shaft seal. The following points shall be ensured:

- A. Inspect for the unblocked connection between the oil return pipe and sealing chamber of shaft seal.
- B. Ensure that no blockage is present in the oil return pipe (insides).

The wearing level or service life of shaft seal varies depending on the operating status and mode of screw air compressor, such as the rotational speed, final pressure, oil pressure, and operating temperature. Therefore the customer shall operate it strictly following the requirements in the instructions for the operation and application, ensuring the normal service life of shaft seal. The installation steps for the shaft seal:

1. Shut down the compressor. Ensure that no restarting will occur and it shall be unloaded;
2. Remove the drive components (such as belt pulleys, coupling and etc.);
3. Remove the keys firstly from the keyway and then from the main shaft;
4. Remove the socket screw and front cover;
5. Remove the inner ring from the main shaft with the dismantling tools or thermal removal tools;
6. Clean the main shaft of compressor. Clear off the grease;
7. Apply a layer of silicon gel on the main shaft at the circumference tightly fitting the inner ring of bearing;
8. Heat the new inner ring to 100°C. And then tightly slide it onto the main shaft until it contacts the limited edge;
9. Before installing the shaft seal, thoroughly clean the main shaft and inner ring. Press the old shaft seal out of the front cover. Clean the front cover and apply a layer of silicon gel on it;
10. Press the shaft seal into the front cover in a proper angle. Clean the silicon gel inside the shaft seal and replace with a new O-ring;
11. Slide the mounting guide ring of shaft seal into the main shaft until it contacts the limited edge;
12. Carefully press the prepared whole set of front cover including the shaft seal and O-ring into the mounting guide ring of shaft seal on the main shaft, and keep it with the compressor outside box to be concentric. It shall be always noted not to damage the lip of shaft seal. Tighten the socket screw to fix the front cover.
13. Press the key into the keyway;
14. Wait for the solidification of silicon gel (for about 30 minutes). And then re-install the drive components. Inspect the oil level in the oil tank. Test the compressor in a short period;
15. Perform the leakage test and inspect the functions of components;
16. Fill in the replacement recording sheet.

3. Service plan

- 1) Every day
 - a. Record the operating status of machine every day. See Table 6-2 for the detailed contents of record.
 - b. Clean the dust-collecting bag of air filter or the inlet silencing chamber. It is not allowed to start the machine without air filter. If the pressure differential switch of air filter acts for the alarm, it will be necessary to maintain the filter core.
 - c. Observe whether the oil level is within the specified range.

-
- d, Inspect the pressure differential switch of oil filter.
 - e, If the intelligent controller sends out the alarm for the blockage in the oil filter, please replace the oil filter.
- 2) Every week (50 hours)
- a, Inspect whether the safety valve is blocked or other damages are present.
 - b, Inspect the oil filter in the first 50 hours since the new machine operates. If necessary, replace the filter core.
 - c, Clean the orifice and screen (if equipped) in the secondary oil return pipeline in the first 50 hours since the new machine operates.
 - d, Inspect the control line filter and drain out the water in the cup (water filter cup).
- 3) 3 months (600 hours)
- a) Clear off the dust at the air inlet of machine.
 - b) Remove the air filter and inspect the filter core. Keep the maintenance of filter core in a good condition.
 - c) Remove the breathing pipeline. Clean and dry it.
 - d) Replace the oil filter for the initial operation.
 - e) Take the oil sample and send it to Screw service department for analysis for the initial operation.
 - f) Inspect the belt tension. If necessary, adjust it.
- 4) Half a year (1000 hours)
- a) Maintain and replace the element of oil filter.
 - b) Inspect and clean the orifice and screen (if equipped) in the secondary oil return pipeline
- 5) One year (2000 hours)
- a) Replace the air filter core.
 - b) Dismantle the gas-water separator. Clean its interior.
 - c) Inspect whether the spring and pin inside the check valve can normally operate. If necessary, replace them.
 - d) Take the oil sample. Send it to the factory for the regular analysis.
 - e) Inspect and calibrate the pressure meter and sensor.
 - f) Inspect the capacity adjusting (loading) solenoid valve (two-position, three-way and normally closed solenoid valve). If necessary, replace the internal sealing ring.
 - g) Review the record of operating status of machine. Identify whether it is necessary to clean the interior of cooler. If necessary, it is best to use the chemical agent to clean it.
 - h) Inspect the quality of cooling water

Table 6-2 Daily inspection record sheet

Items	Reference value							
Discharge pressure	xxx bar							
Ambient (inlet) temperature	≤45℃							
Discharge temperature	≤95℃							
Oil level	Green area							
Drainage period of electronic water discharge valve	1-2 seconds							

6) Preparations for the long-term shutdown

If the interval between shutdown and restart is relatively long, please turn on the manual switch of the (electronic) water (waste-water) discharge valve before the shutdown, and allow the draining period not to be less than 5 minutes, ensuring that the water in the system is completely drained out. The accumulated water in the components such as the cooler, air tank and etc. shall be discharged after the shutdown.

a, Shutdown period less than 1 month

- It is necessary to start the machine once every week and allow the machine to operate at unloading for 10 minutes.
- Manually turn the coupling once every week .

b, Shutdown period exceeding 1 month

(A) Shutdown preparation

- Continuously load it for 10 minutes to discharge the air in the pipe.
Remember: Drain out the water inside two gas-water separators
- Manually turn the coupling after the shutdown.
- Discharge the water in the components such as the cooler, air tank and etc.

(B) During the shutdown

- Repeat (A) once every other three months

(C) Before the restarting

- Replace the oil inside the oil tank
- Open the water discharge valve in the gas-water separator
- Manually turn the connecting component (coupling) between the motor and main machine, ensuring that the rotation is easy.

4. Maintenance Standards

No	Maintenance part	Check	Inspection time						Notes
			Daily	1month	1/2 year	1year	2year	4 year	
1	Oil level gauge	Oil level check	○						Oil level must be within red lines during operation.
2	Discharge temp.	Discharge temp.check	○						between 71°C~100°C
3	Discharge pressure.	Pressure check	○						Above 0.4mpa
4	Oil sight glass	check		○					Clean when jammed
5	Pipe seal	Oil/air leak check		○					Tighten
6	Drain valve	check		○					Clean if jammed
7	Air filter	Cleaning/replacement		○	●				Clean by blowing every month,and replace every 1/2 year .
8	Oil filter	Replacement			●				Replace if the error code
9	Belt pulley	check			○	●			Replace if it is abnormal.
10	Lubricant	Replacement				●			Replace every 1/2 year.
11	belt	Checking/replacement				●			Replace if it is abnormal.
12	hose	Oil/air leak check				●			Replace when it leaked.
13	Oil separator	Replace				●			Replace if the pressure difference over 0.8kg.
14	cooler	Check/cleaning			○				Clean every 1/2 year
15	Minimum pressure valve seal	Check					●		Replace when the air leaked
16	Thermostatic valve	Replacement					●		Replace when abnormal
17	Suction valve	Replacement					●		Replace when abnormal
18	Electric element						●		Replace when abnormal
19	diaphragm	Check/replacment				●			Replace when damaged.
20	Pressure sensor	Check					●		Replace when have pressure warp
21	Temp. sensor	Check if temp.is exact					●		Replace if not
22	Belt pulley	check					●		Replace when damaged
23	Shaft sealing	Check				●			Replace when leaked
24	Suction valve							●	Replace when damaged
25	Fan							●	Replace when the current and noise abnormal
26	Bearing of air end							●	Replace when have abnormal noise

The maintenance items marked with ○ must be carried out by users or, optionally, may be ordered to the dealer.

The maintenance items marked with ● must be ordered to the dealer.

Chapter 7 Troubleshooting

Failure 1: Over-High discharge air temperature

---The discharge air temperature is equal to or above 110°C.

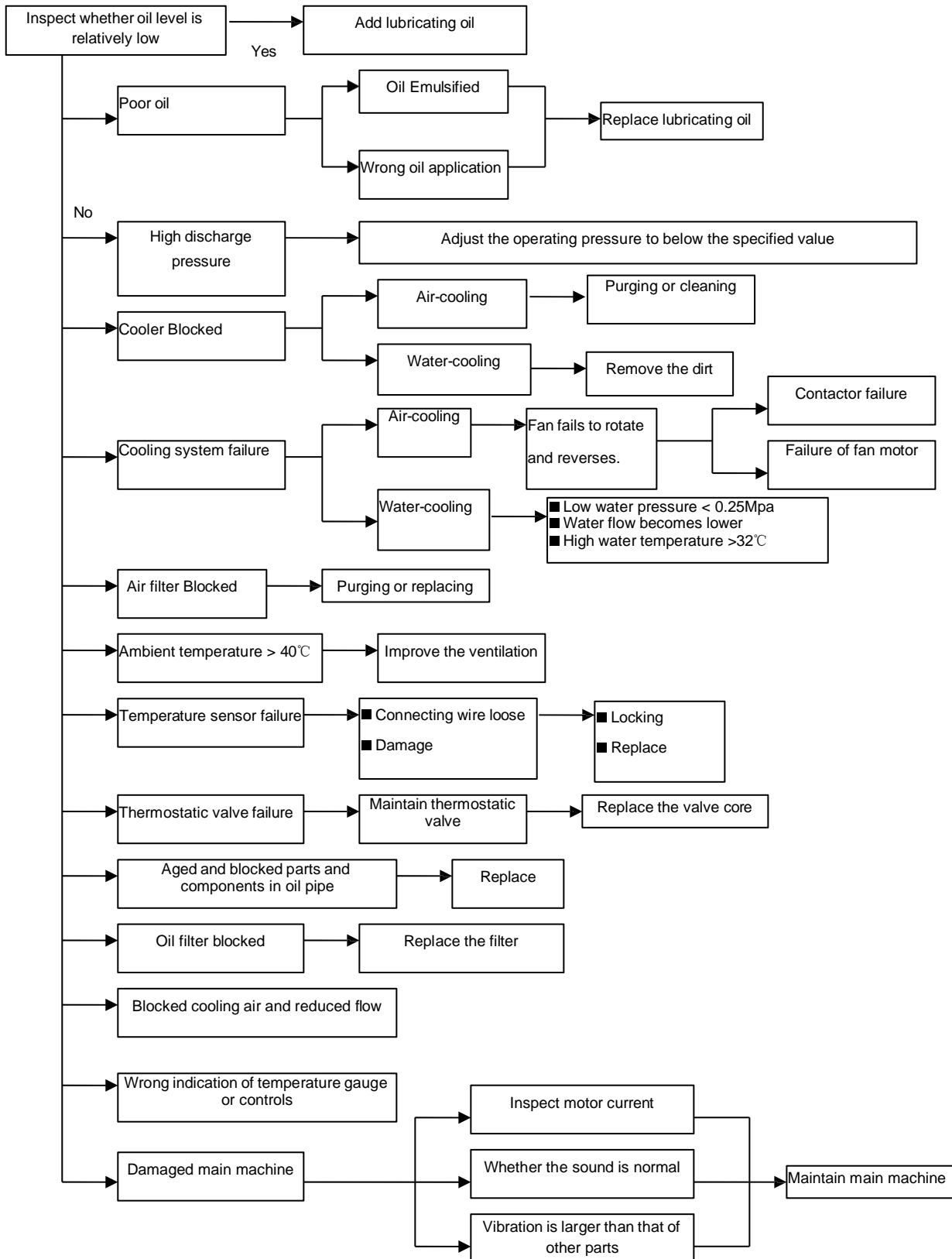

Failure 2: Oil over-consumption

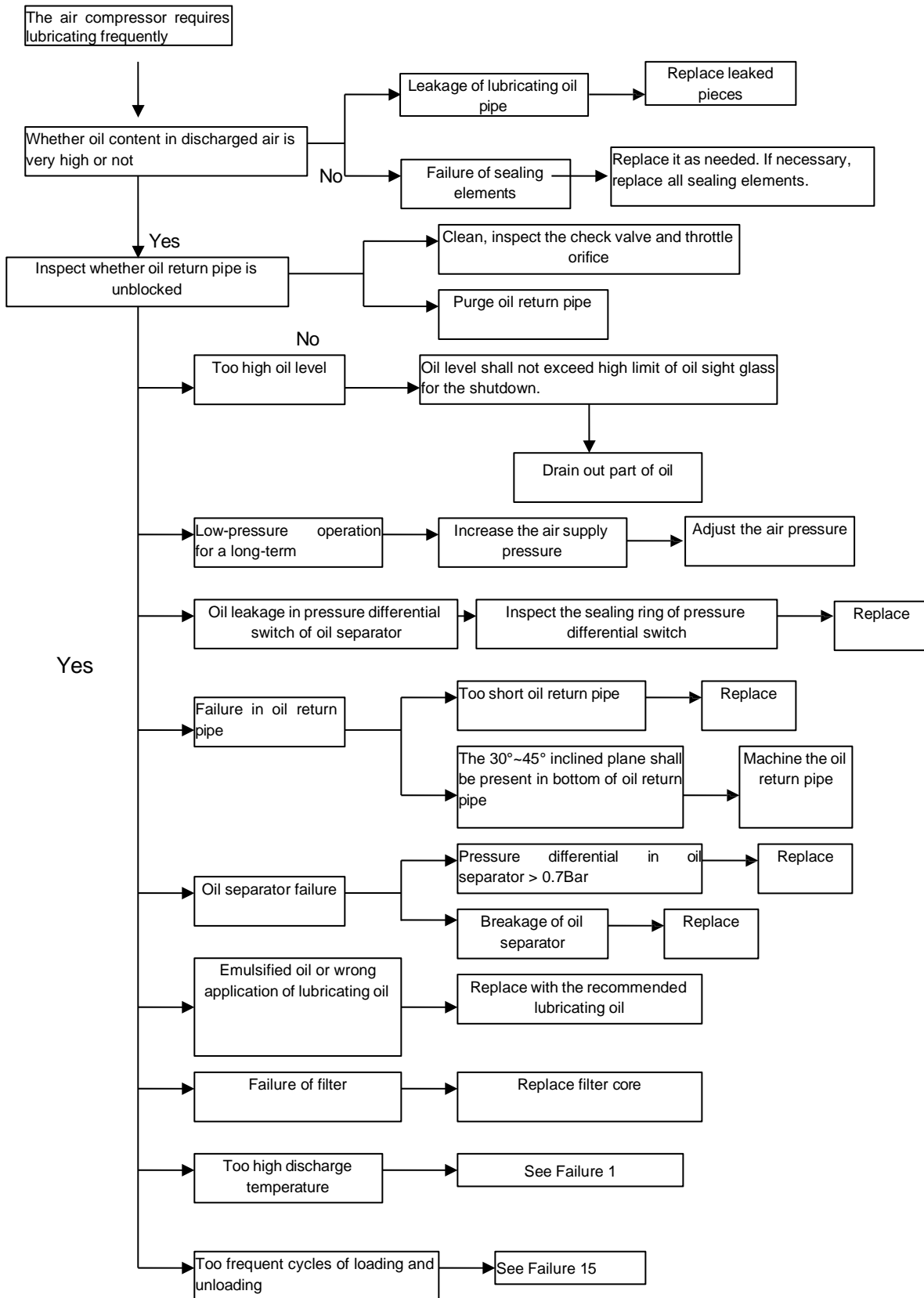

Failure 3: Overload or blockage of main motor

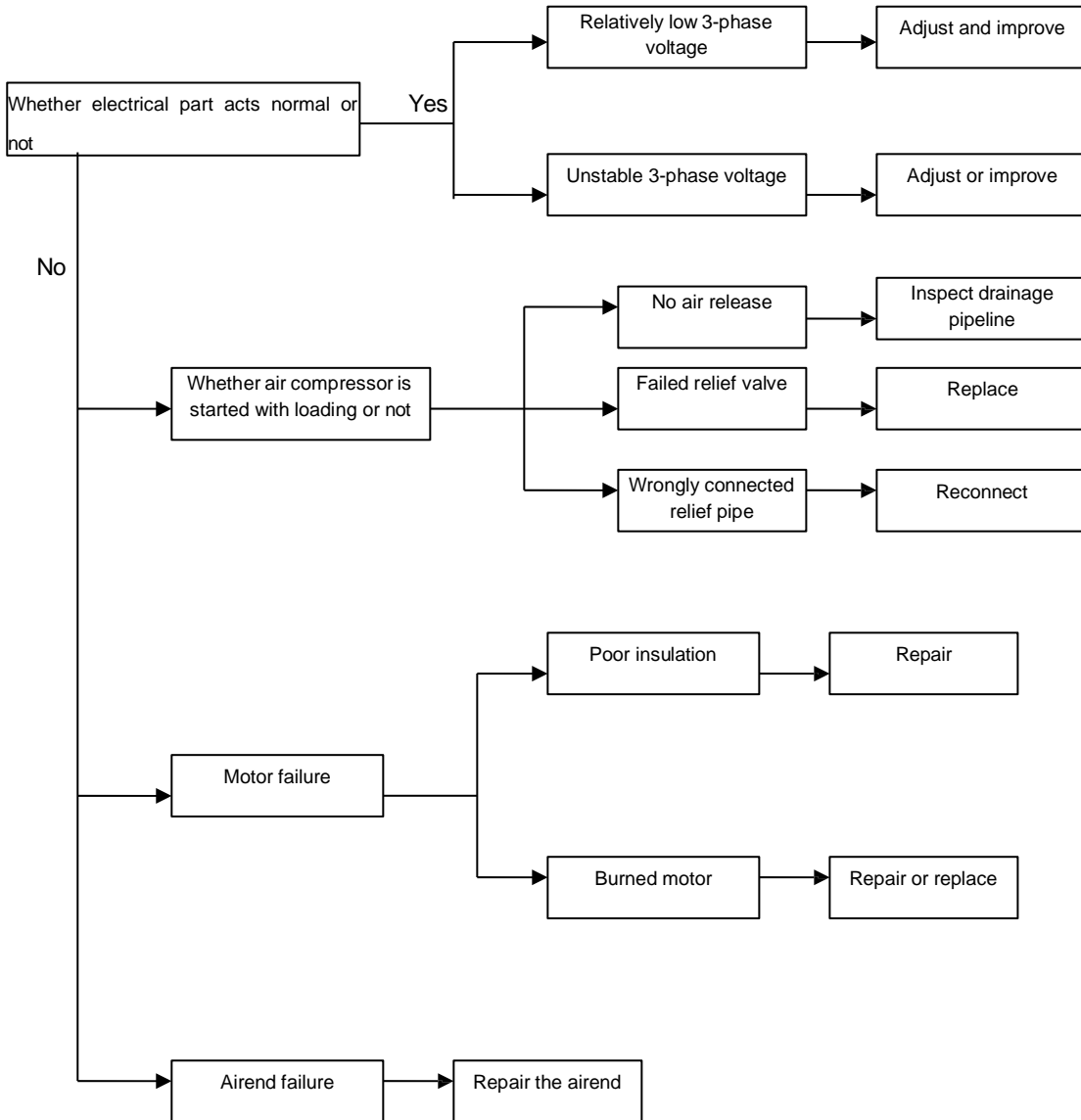

Failure 4: Abnormal shutdown during operation

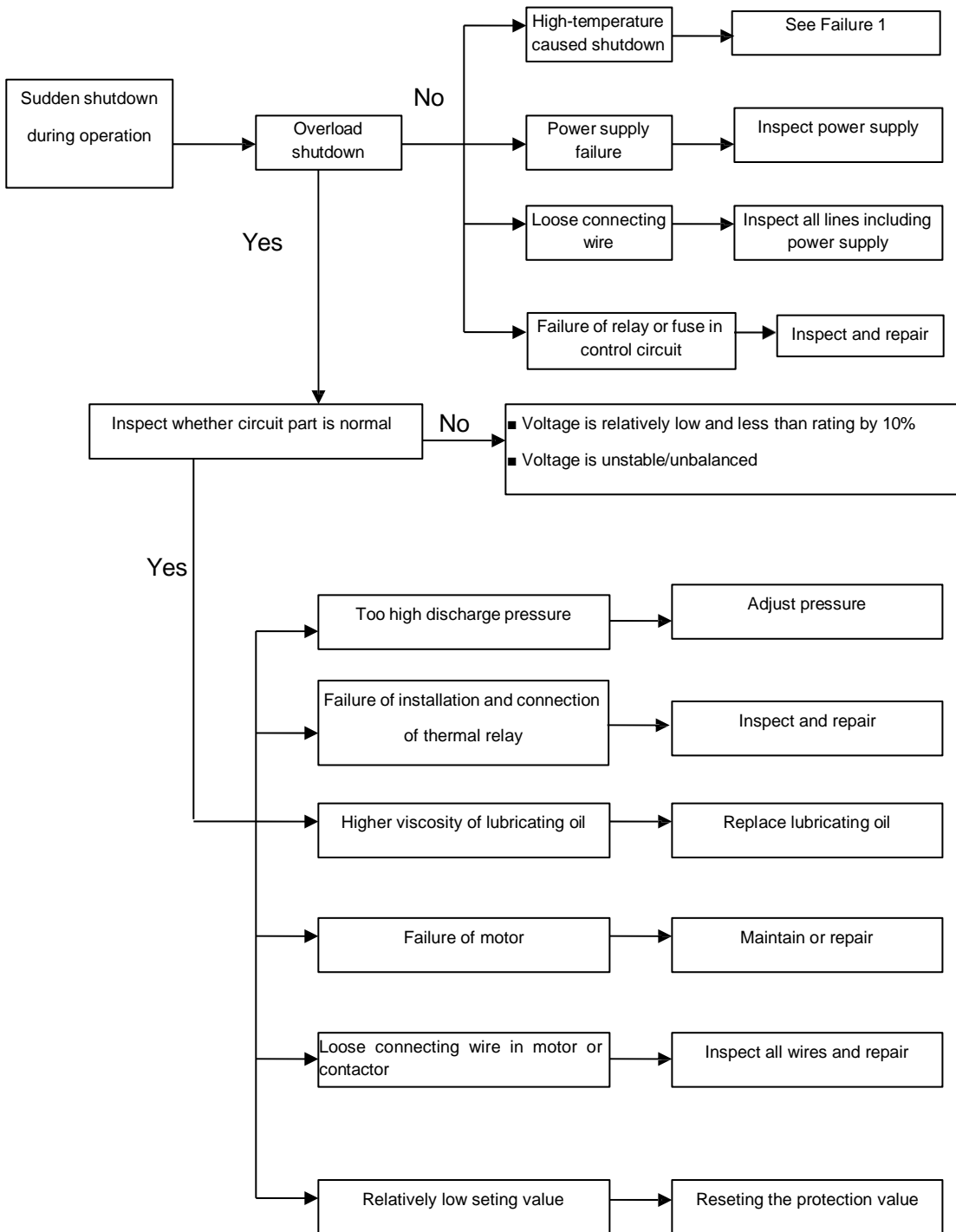

Failure 5: Low air output

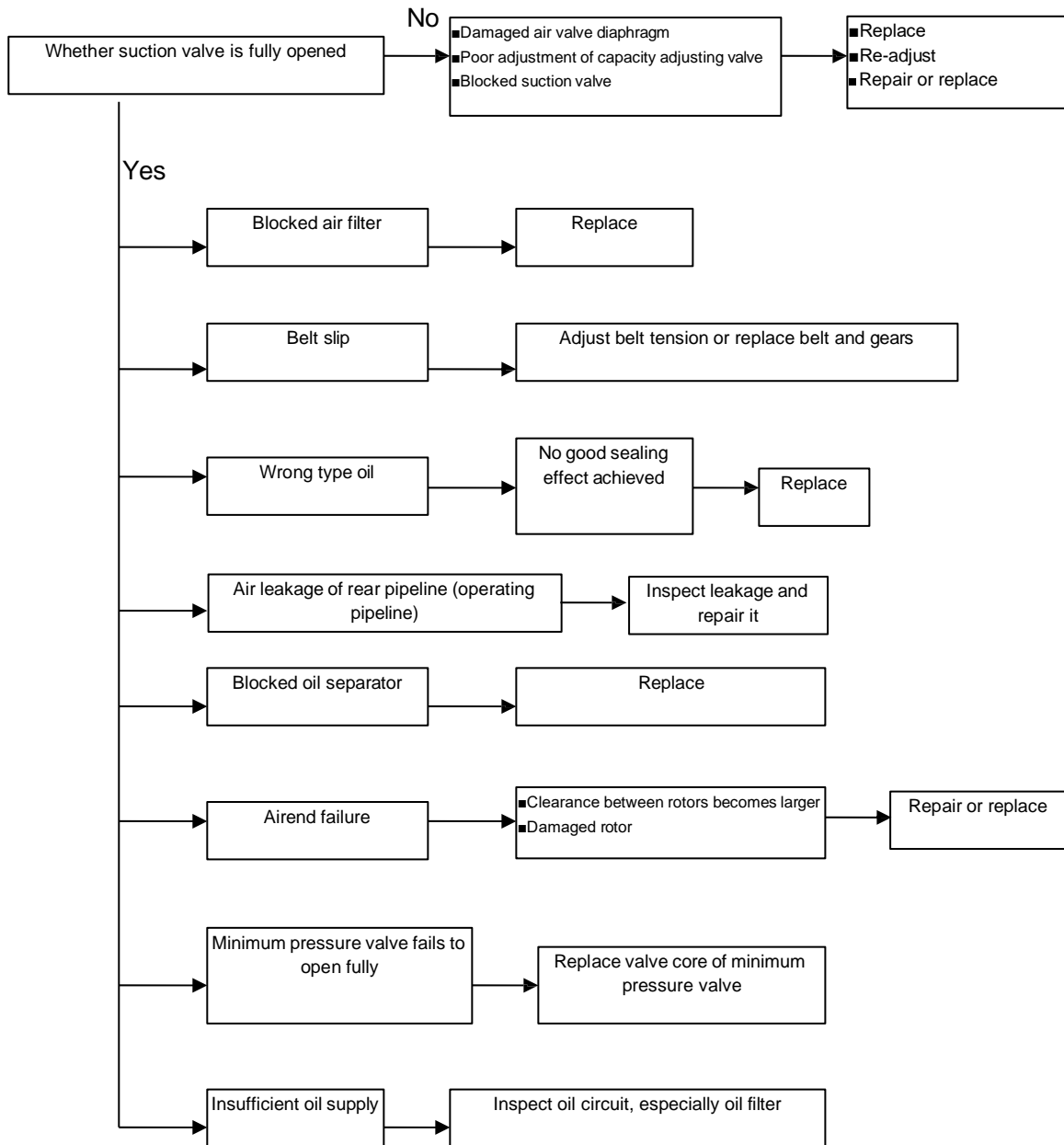

Failure 6: No indication on display screen

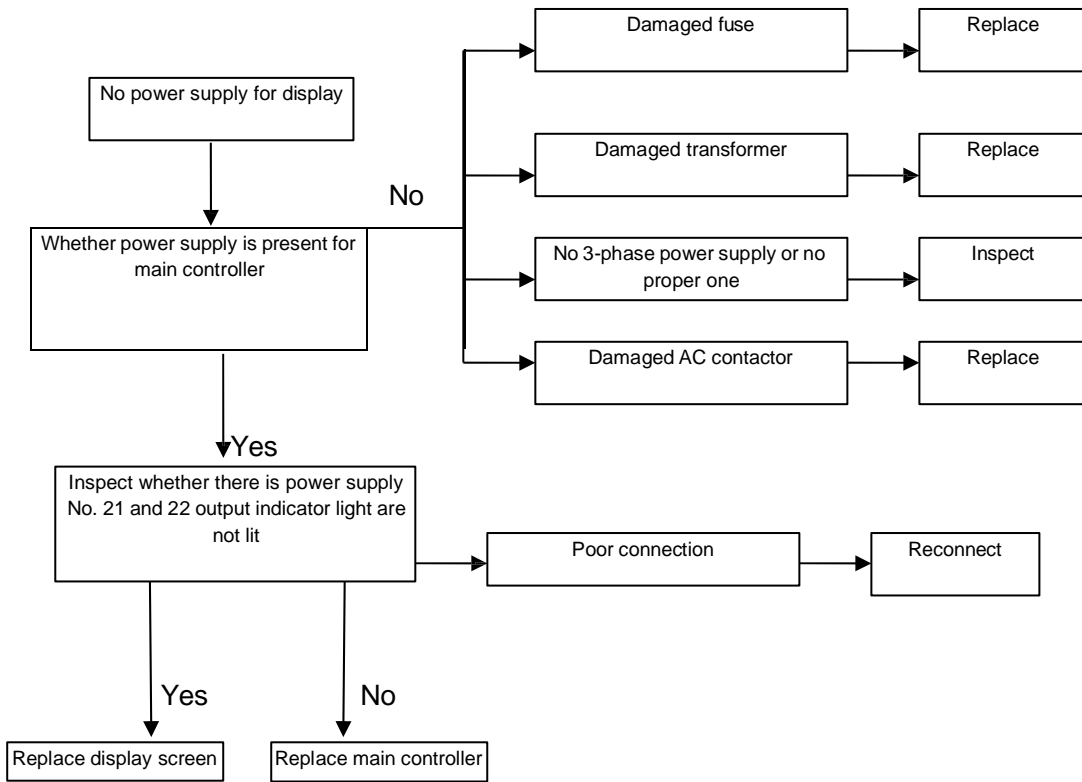

Failure 7: Indicating the data without starting (failing to start)

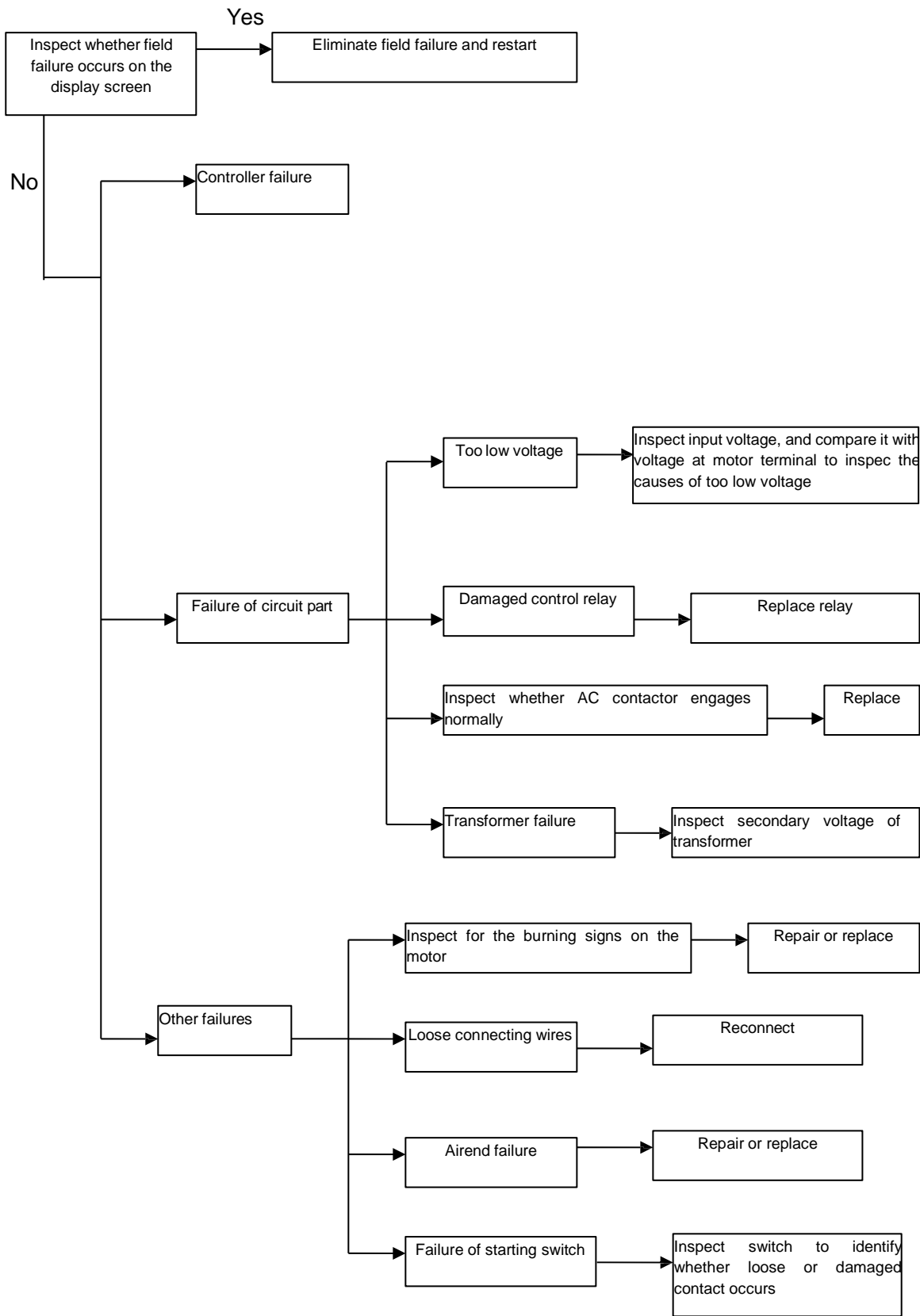

Failure 8: Too low pressure in air tank

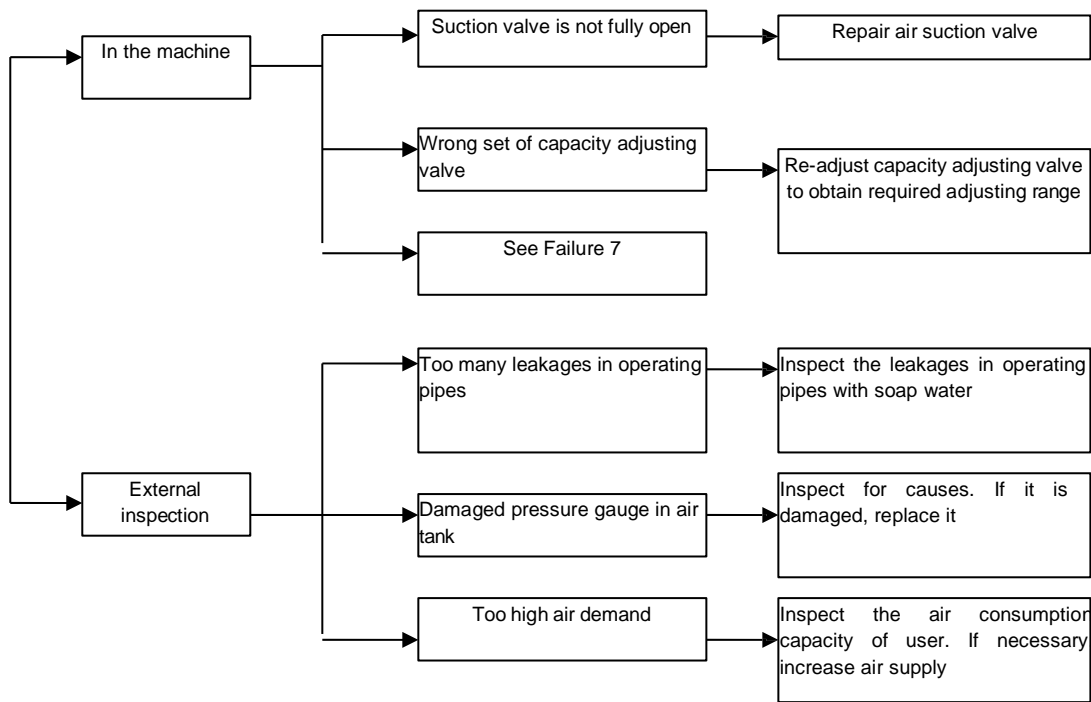

Failure 9: Too high pressure in air tank

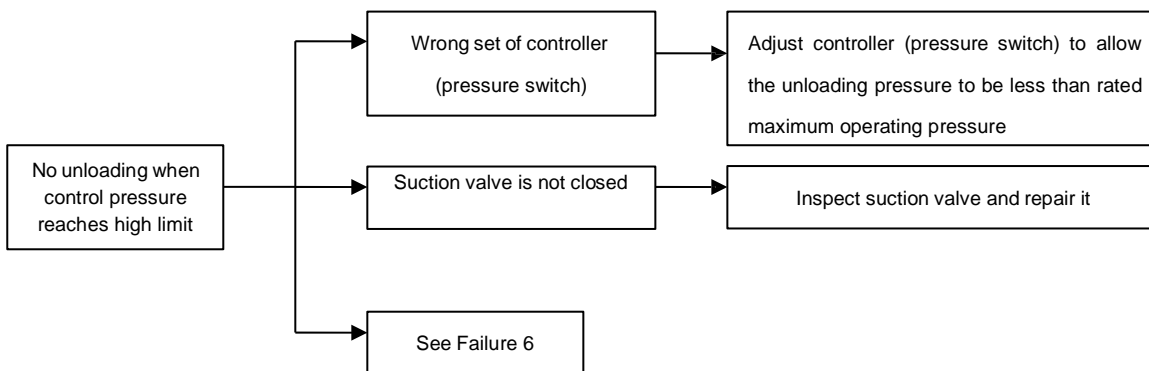

Failure 10: Frequent blockages in oil/air separator

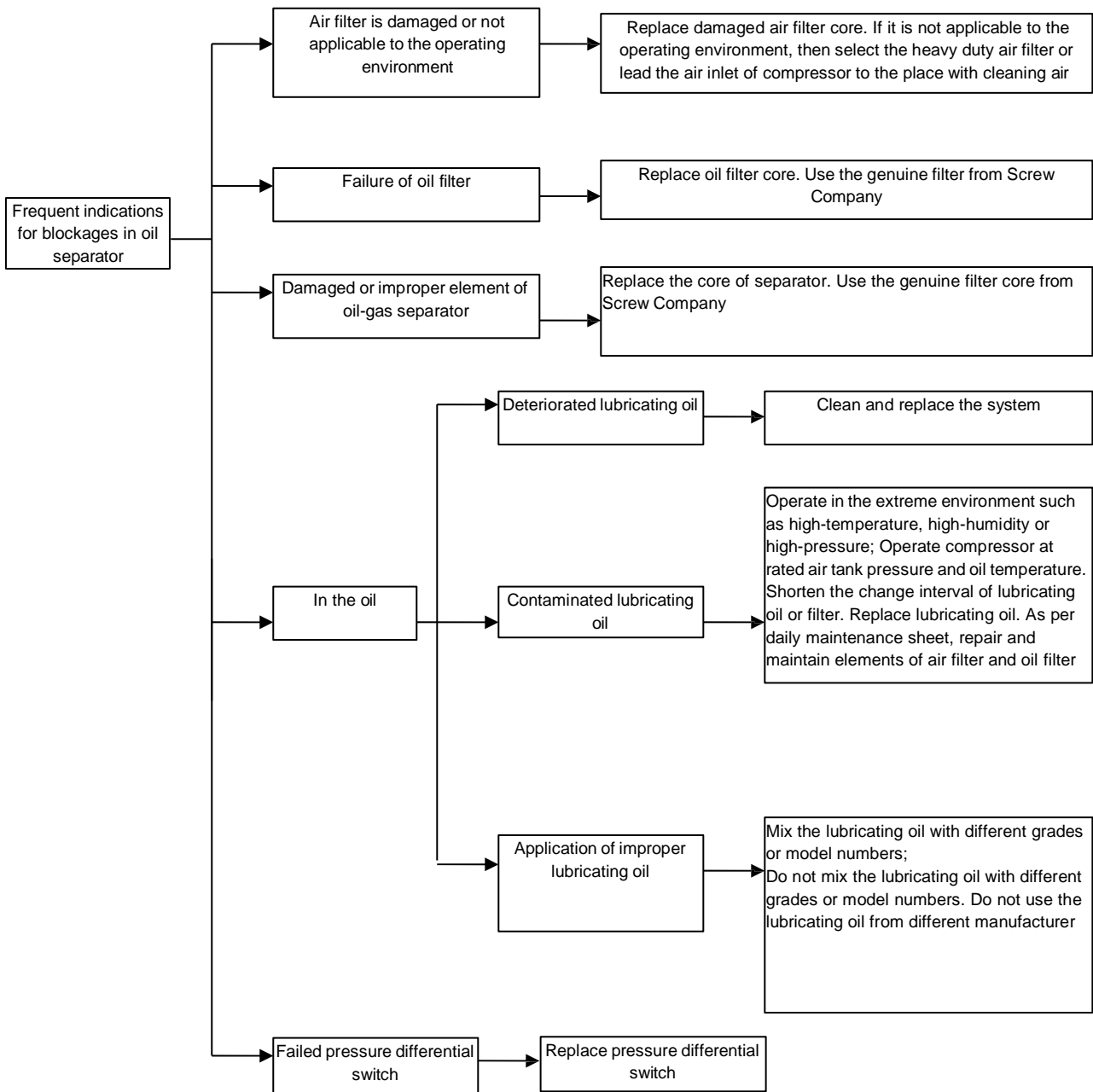

Failure 11: Frequent blockages in oil filter

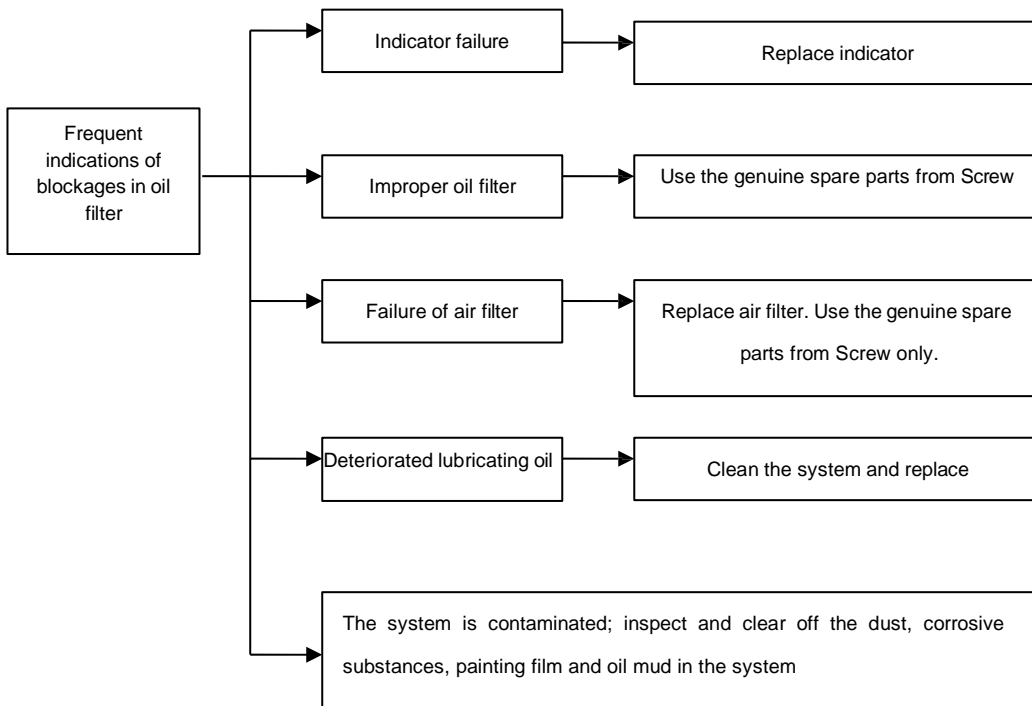

Failure 12: Frequent blockages in air filter

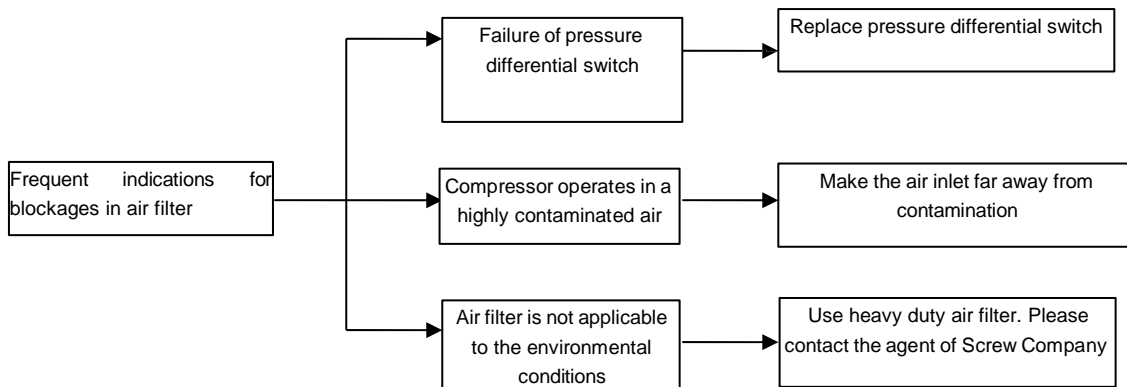

Failure 13: Excessive water content in compressed air at discharge end

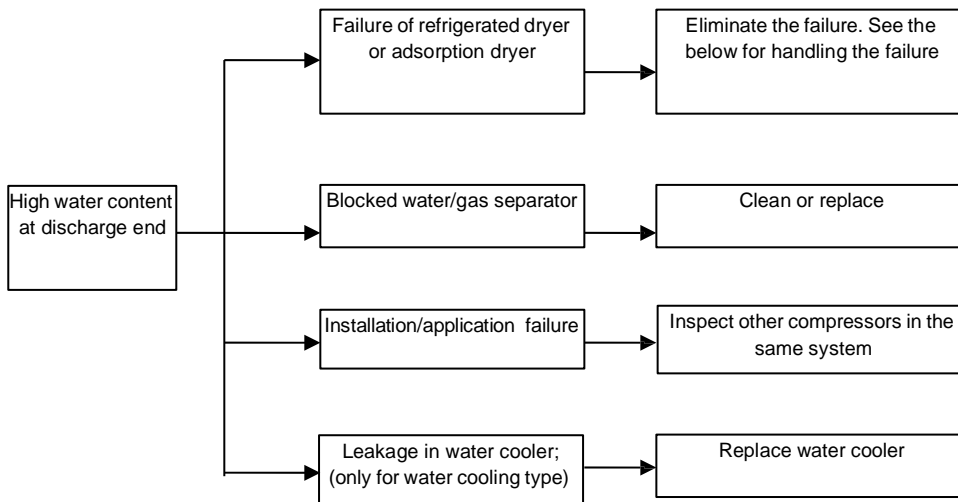

Failure 14: Abnormal opening of safety valve

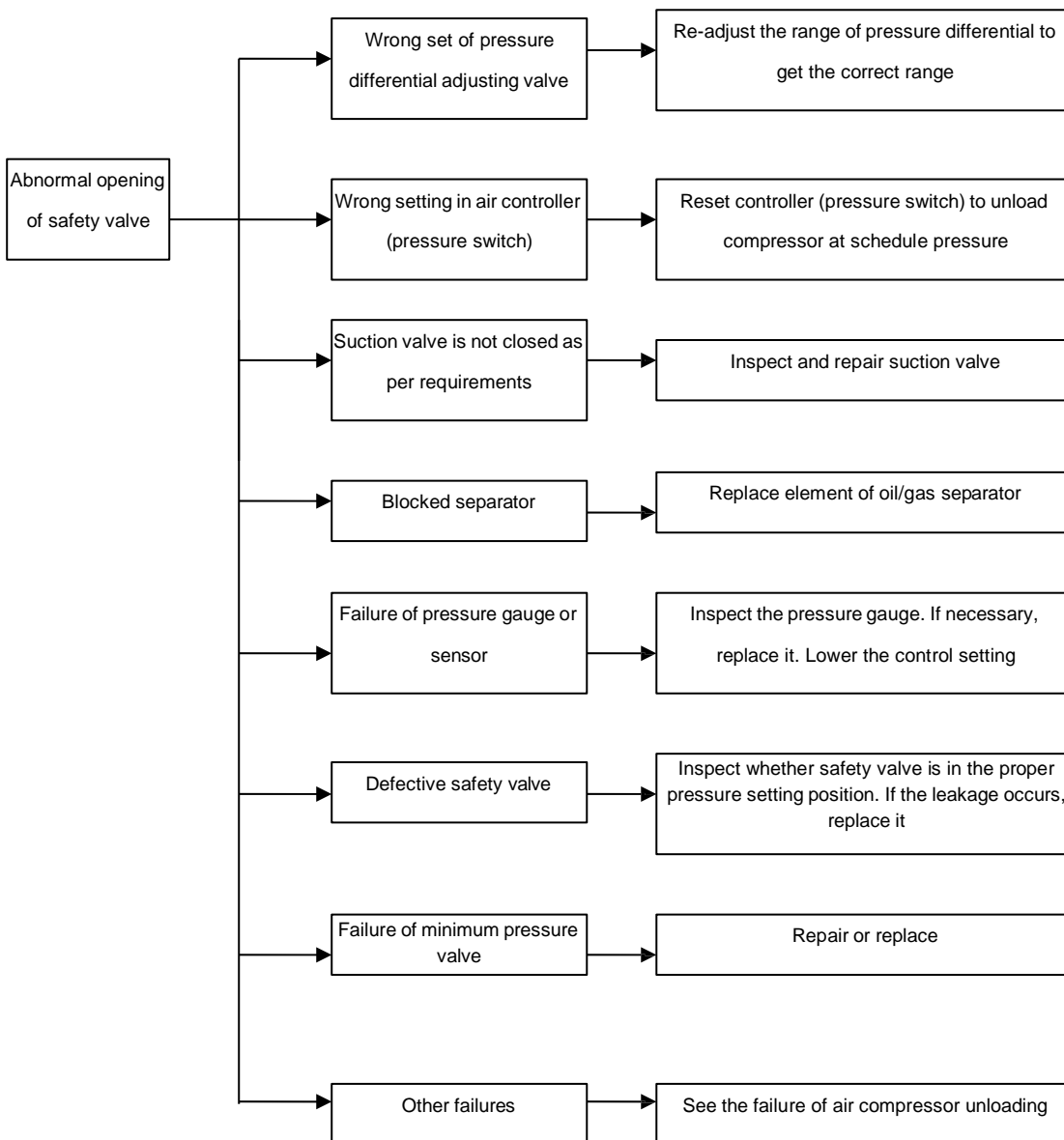

Failure 15: Abnormal noises in the air compressor

----Pressure sensor can't detect the pressure in 2 seconds after starting

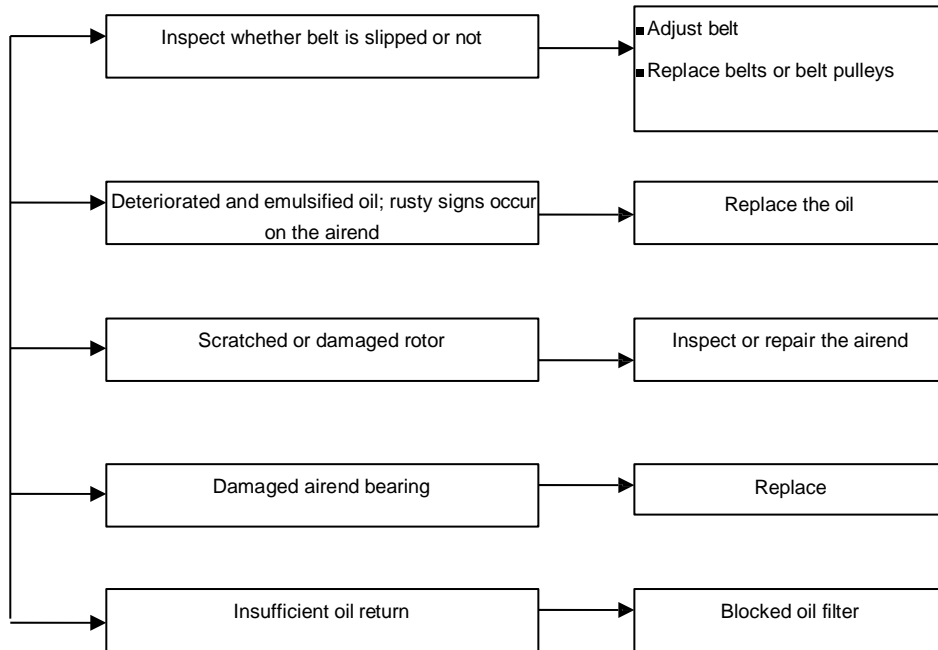

Failure 16: Oil injection in suction valve during shutdown

